

GNG 1505– Mécanique pour Ingénieurs

DGD-1 / Problèmes suggérées

2.8 Un câble téléphonique est attaché au point A du poteau AB. Sachant que la tension au côté droit du câble est de $T_2 = 1000$ N, déterminez par trigonométrie :

- la tension T_1 requise au côté gauche si la résultante \mathbf{R} des forces exercées sur le câble au point A doit être verticale ;
- la grandeur correspondante de \mathbf{R} .

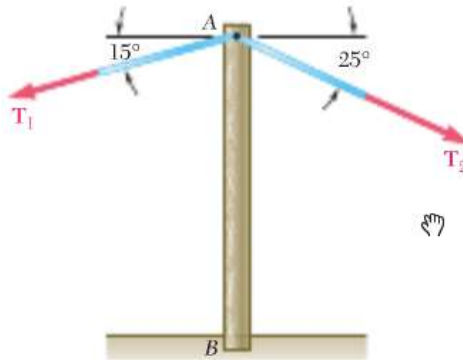
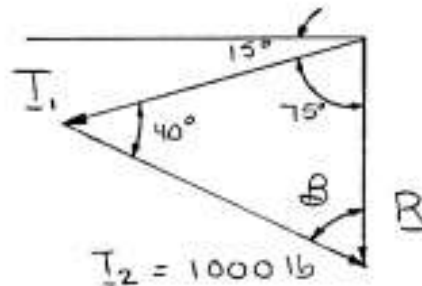

Figure P2.7 - P2.8

SOLUTION



Using the triangle rule and the law of sines:

$$\begin{aligned} (a) \quad 75^\circ + 40^\circ + \beta &= 180^\circ \\ \beta &= 180^\circ - 75^\circ - 40^\circ \\ &= 65^\circ \end{aligned}$$

$$\frac{1000 \text{ lb}}{\sin 75^\circ} = \frac{T_1}{\sin 65^\circ}$$

$$T_1 = 938 \text{ lb} \quad \blacktriangleleft$$

$$(b) \quad \frac{1000 \text{ lb}}{\sin 75^\circ} = \frac{R}{\sin 40^\circ}$$

$$R = 665 \text{ lb} \quad \blacktriangleleft$$

- 2.9** On applique sur un crochet deux forces distinctes. Sachant que la grandeur de la force **P** est de 35 N, déterminez par trigonométrie :
- la valeur de l'angle α si la résultante **R** des deux forces doit être horizontale ;
 - la grandeur correspondante de **R**.

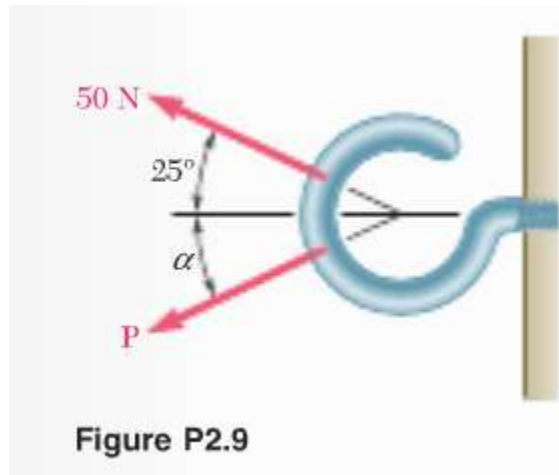

SOLUTION

Using the triangle rule and law of sines:

(a)
$$\frac{\sin \alpha}{50 \text{ N}} = \frac{\sin 25^\circ}{35 \text{ N}}$$

$$\sin \alpha = 0.60374$$

$$\alpha = 37.138^\circ$$

(b)
$$\alpha + \beta + 25^\circ = 180^\circ$$

$$\beta = 180^\circ - 25^\circ - 37.138^\circ$$

$$= 117.862^\circ$$

$$\frac{R}{\sin 117.862^\circ} = \frac{35 \text{ N}}{\sin 25^\circ}$$

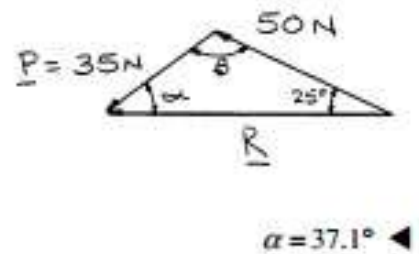

$R = 73.2 \text{ N} \blacktriangleleft$

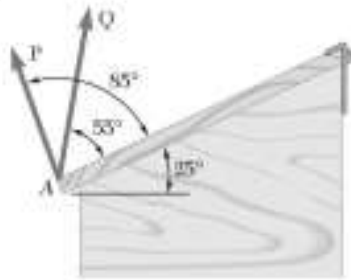

PROBLEM 2.19

Two forces **P** and **Q** are applied to the lid of a storage bin as shown. Knowing that $P = 48 \text{ N}$ and $Q = 60 \text{ N}$, determine by trigonometry the magnitude and direction of the resultant of the two forces.

SOLUTION

Using the force triangle and the laws of cosines and sines:

We have
$$\gamma = 180^\circ - (20^\circ + 10^\circ) = 150^\circ$$

Then
$$R^2 = (48 \text{ N})^2 + (60 \text{ N})^2 - 2(48 \text{ N})(60 \text{ N})\cos 150^\circ$$

$$R = 104.366 \text{ N}$$

and
$$\frac{48 \text{ N}}{\sin \alpha} = \frac{104.366 \text{ N}}{\sin 150^\circ}$$

$$\sin \alpha = 0.22996$$

$$\alpha = 13.2947^\circ$$

Hence:
$$\phi = 180^\circ - \alpha - 80^\circ = 180^\circ - 13.2947^\circ - 80^\circ = 86.705^\circ$$

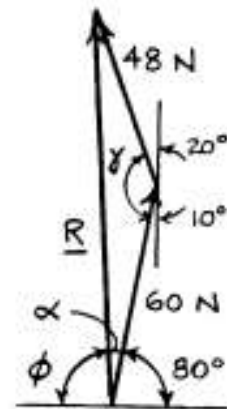

$$R = 104.4 \text{ N} \nearrow 86.7^\circ \blacktriangleleft$$

2.21 et 2.22 Déterminez les composantes x et y de chacune des forces présentes.

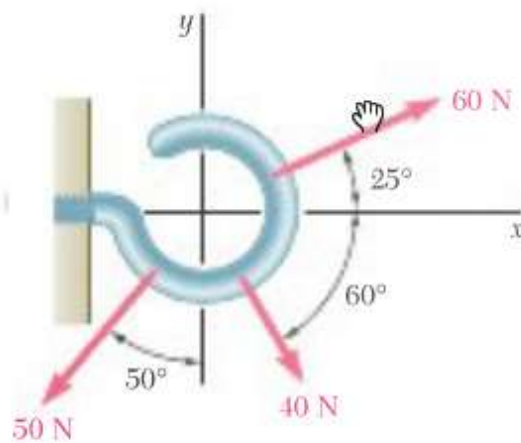
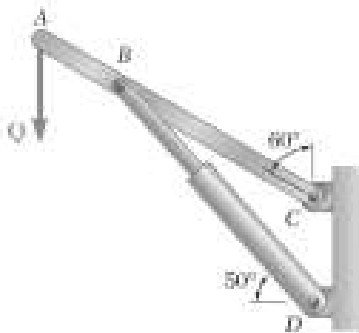

Figure P2.22

SOLUTION

40-lb Force:	$F_x = +(40 \text{ lb}) \cos 60^\circ$	$F_x = 20.0 \text{ lb} \leftarrow$
	$F_y = -(40 \text{ lb}) \sin 60^\circ$	$F_y = -34.6 \text{ lb} \leftarrow$
50-lb Force:	$F_x = -(50 \text{ lb}) \sin 50^\circ$	$F_x = -38.3 \text{ lb} \leftarrow$
	$F_y = -(50 \text{ lb}) \cos 50^\circ$	$F_y = -32.1 \text{ lb} \leftarrow$
60-lb Force:	$F_x = +(60 \text{ lb}) \cos 25^\circ$	$F_x = 54.4 \text{ lb} \leftarrow$
	$F_y = +(60 \text{ lb}) \sin 25^\circ$	$F_y = 25.4 \text{ lb} \leftarrow$



PROBLEM 2.25

The hydraulic cylinder BD exerts on member ABC a force \mathbf{P} directed along line BD . Knowing that \mathbf{P} must have a 750-N component perpendicular to member ABC , determine (a) the magnitude of the force \mathbf{P} , (b) its component parallel to ABC .

SOLUTION

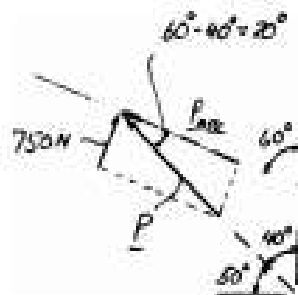

(a) $750 \text{ N} = P \sin 20^\circ$
 $P = 2192.9 \text{ N}$ $P = 2190 \text{ N} \blacktriangleleft$

(b) $P_{ABC} = P \cos 20^\circ$
 $= (2192.9 \text{ N}) \cos 20^\circ$ $P_{ABC} = 2060 \text{ N} \blacktriangleleft$

2.35 En vous référant à la figure P2.35 et sachant que $\alpha = 35^\circ$, déterminez la résultante des trois forces illustrées.

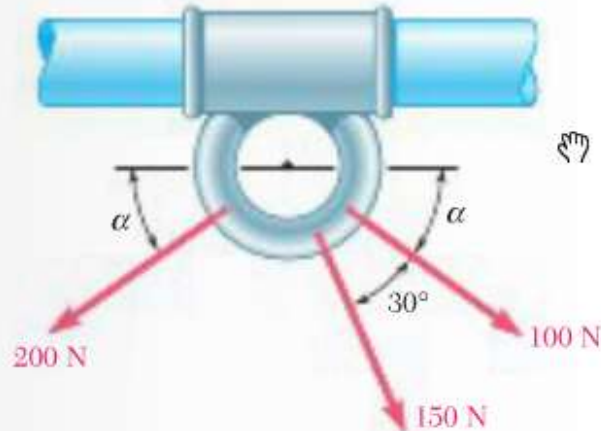

Figure P2.35

SOLUTION

100-N Force: $F_x = +(100 \text{ N}) \cos 35^\circ = +81.915 \text{ N}$
 $F_y = -(100 \text{ N}) \sin 35^\circ = -57.358 \text{ N}$

150-N Force: $F_x = +(150 \text{ N}) \cos 65^\circ = +63.393 \text{ N}$
 $F_y = -(150 \text{ N}) \sin 65^\circ = -135.946 \text{ N}$

200-N Force: $F_x = -(200 \text{ N}) \cos 35^\circ = -163.830 \text{ N}$
 $F_y = -(200 \text{ N}) \sin 35^\circ = -114.715 \text{ N}$

Force	x Comp. (N)	y Comp. (N)
100 N	+81.915	-57.358
150 N	+63.393	-135.946
200 N	-163.830	-114.715
	$R_x = -18.522$	$R_y = -308.02$

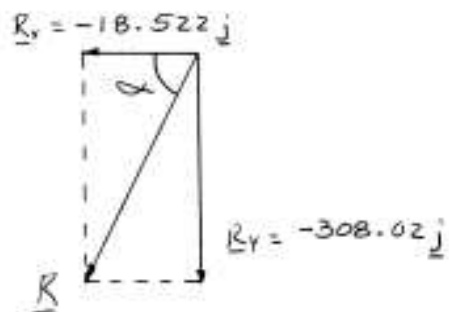

$$\mathbf{R} = R_x \mathbf{i} + R_y \mathbf{j}$$

$$= (-18.522 \text{ N})\mathbf{i} + (-308.02 \text{ N})\mathbf{j}$$

$$\tan \alpha = \frac{R_y}{R_x}$$

$$= \frac{308.02}{18.522}$$

$$\alpha = 86.559^\circ$$

$$R = \frac{308.02 \text{ N}}{\sin 86.559}$$

$\mathbf{R} = 309 \text{ N} \nearrow 86.6^\circ \blacktriangleleft$