

CARLETON UNIVERSITY
Department of Mechanical and Aerospace Engineering
ENGINEERING MAAE 2300 - FLUID MECHANICS I
Example Final Examinations

Answers:

December 2006

1. Note: you are asked for the net fluid force. P_{atm} contributes to the pressure on both sides. Therefore, you only need to determine hydrostatic force on the water side.
 $F_R = 164100 \text{ N}$. $y_R = 1.087 \text{ m}$, measured from top edge of window.
2. (a) $Q = 0.421 \text{ l/min}$
(b) $Q = 0.493 \text{ l/min}$
3. (a) $P_A = 97,095 \text{ Pa(a)}$. Given that this is air, would there be any noticeable change in the pressure between A and the lower manometer?
 $P_B = 101,680 \text{ Pa(a)}$
(b) $F_X = 1980 \text{ N}$ to the right
(c) $M_Z = 5671 \text{ Nm}$
(d) Increase. Why?
(e) 46.4 HP
4. (a) $P = 391.7 \text{ kPa(g)}$
(b) $F_B = 6456 \text{ N}$ in tension
5. (a) $P = 662.5 \text{ kPa(g)}$
(b) $F = 3731 \text{ N}$. There is no friction on the outside of the hose. However, the water flowing through the hose does of course exert a frictional force on the inside of the hose.
(c) $V = 15.3 \text{ m/s}$
(d) Yes. Consider the Reynolds numbers and relative roughness for the two cases.

December 2005

1. $d = 2.657 \text{ m}$

The force required in the cable is 24,525 N. The moment due to this about the hinge H must be balance by the moment do to the hydrostatic force F_R acting normal to the gate at the centre of pressure. There is no net contribution due to the free surface pressure P_s since it is balanced by P_{atm} acting on the back side of the gate.

2. $Q = 0.491 \text{ m}^3/\text{s}$

3. (a) $V_{out} = 12.7 \text{ m/s}$

For parts (b) to (d) a value of $V_{out} = 15 \text{ m/s}$ was to be used. Depending on whether the volume flow rate (and mass flow rate) was adjusted to be consistent with this, slightly different values will be obtained (and were accepted) for parts (b) to (d).

(b) Depending on the assumptions made, would obtain either 49 or 10 N. Either answer was accepted, if the assumptions were clearly stated.

(c) 300 N. Would slide in positive y direction.

(d) 6.7 HP

4. (a) $F_H = -73,100 \text{ N}$. Use a CV attached to the aircraft. Since the thrust reverser is intended to decelerate the aircraft, this is not in fact an unaccelerated frame of reference. However, we do not know the deceleration rate and neglect it for purposes of the analysis.

(b) Force in tailcone $F_{TC} = -140,600 \text{ N}$ and it is in tension.

5. (a) 0.75 mm

(b) 0.31 °C

(c) 149 m

December 2003

1. (a) $F_H = 3.521 \times 10^6 \text{ N}$ at 16.987 m from free surface.

(b) $F_H = 2.825 \times 10^6 \text{ N}$

2. $H = 40.9 \text{ m}$

3. (a) $Q = 64.9 \text{ m}^3/\text{s}$

(b) $F = 760,000 \text{ N}$

4. $M = 2.01 \times 10^4 \text{ Nm}$ $\dot{W} = 3950 \text{ HP}$

5. (a) $\dot{W}_{pump} = 543 \text{ kW}$ $\dot{W}_{shaft} = 679 \text{ kW}$

(b) $y_{Cmax} = 236 \text{ m}$

(c) Move pump closer to point C. In the area of C, replace some of the pipe with pipe of larger diameter to reduce the flow velocity and thus raise the static pressure.

CARLETON UNIVERSITY

Final
EXAMINATION
December 2006

DURATION: **3** HOURS

No. of Students: **111**

Department Name & Course Number: **Mechanical & Aerospace Engineering, MAAE 2300A**

Instructor(s) **S.A. Sjolander**

AUTHORIZED MEMORANDA

1 sheet 8 1/2 x 11, both sides, any non-transmitting calculator

Students **MUST** count the number of pages in this examination question paper **before** beginning to write, and report any discrepancy immediately to a proctor. This question paper has **7** pages.

This examination question paper **MAY** be taken from the examination room.

ATTEMPT ALL QUESTIONS. THE VALUE OF EACH QUESTION IS GIVEN IN THE MARGIN. DRAW COMPLETE AND FULLY-LABELLED FREE-BODY DIAGRAMS OR CONTROL VOLUMES WHERE APPROPRIATE.

Geometric properties of common cross sections:

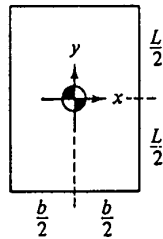

$$A = bL$$

$$I_{xx} = \frac{bL^3}{12}$$

$$I_{xy} = 0$$

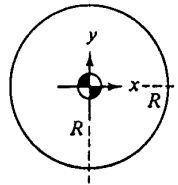

$$A = \pi R^2$$

$$I_{xx} = \frac{\pi R^4}{4}$$

$$I_{xy} = 0$$

Miscellaneous data:

Air: $R = 287 \text{ Nm/kgK}$
 $C_p = 1005 \text{ Nm/kgK}$
 $C_v = 716 \text{ Nm/kgK}$

Water: $\rho = 1000 \text{ kg/m}^3$
 $= 62.4 \text{ lb}_m/\text{ft}^3$
 $C_v = 4180 \text{ Nm/kgK}$

$$^{\circ}\text{R} = ^{\circ}\text{F} + 460$$

$$^{\circ}\text{K} = ^{\circ}\text{C} + 273$$

$$1 \text{ litre} = 1000 \text{ cm}^3$$

$$g = 32.174 \text{ ft/sec}^2$$

$$= 9.81 \text{ m/s}^2$$

$$1 \text{ HP} = 550 \text{ ft-lb}_f/\text{sec}$$

$$= 745 \text{ Nm/s}$$

See Page 7 for additional data.

1. The drawing shows a large fish tank at a public aquarium. For viewing the fish, the tank has a series of rectangular glass windows mounted in the wall. Each window is 3 m wide in the horizontal direction and 2 m in length in the other direction, as shown. Determine the net fluid force on the window and the line of action of the force measured from the top edge of the window.

[15]

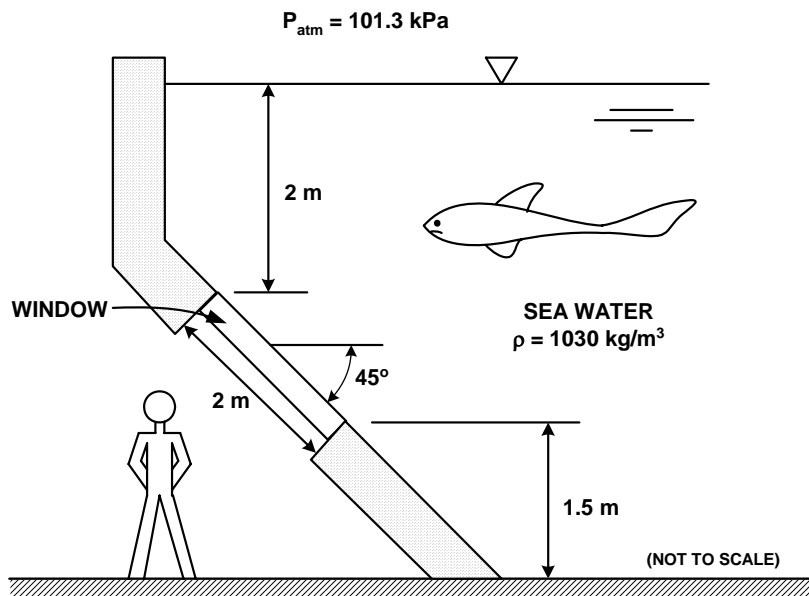

- 2 The drawing shows a simple insecticide sprayer that is intended to be attached to a garden hose. The insecticide is drawn from the container to mix with the water and the mixture is then sprayed through the 2.5 mm diameter outlet nozzle. Neglect friction in your analysis. State any other simplifying assumptions used.
- [12] (a) What is the flow rate of water in litres/min (recall that $1 \text{ m}^3 = 1000$ litres) for the conditions shown in the drawing? As indicated in the sketch, the insecticide has been drawn up the 1.0 mm diameter tube but is not flowing into the sprayer tube.
- [8] (b) The recommended mixture is 10 parts water to 1 part insecticide. Determine the flow rate of water required to obtain a spray at the nozzle outlet with this mixture. It is possible, although not necessary, to simplify the analysis slightly by using the fact that flow rate of insecticide in the sprayer tube is small compared with the flow rate of water.

[20]

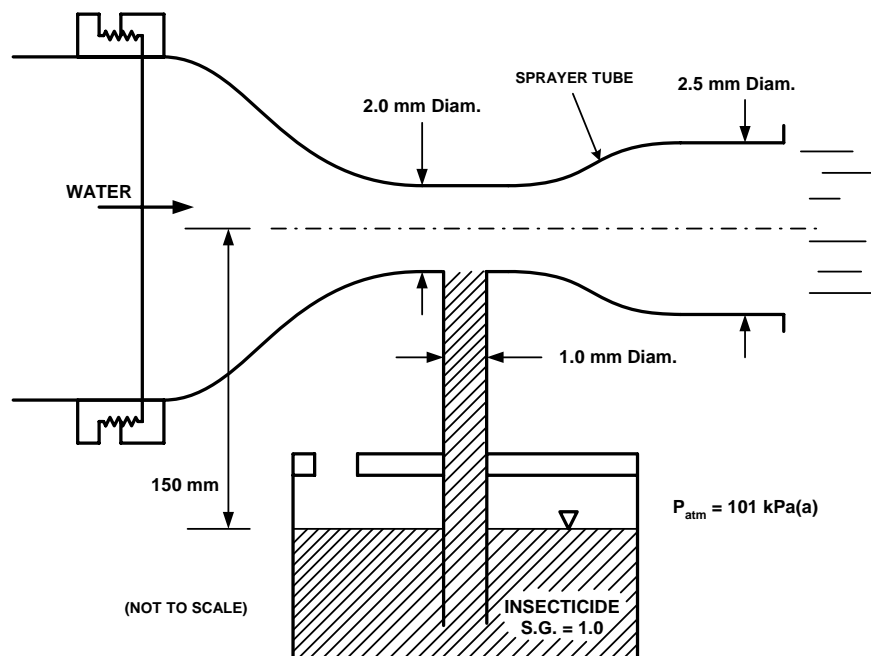

3. The drawing shows a ventilation fan that draws $300 \text{ m}^3/\text{min}$ of air from an underground mine and exhausts it to the atmosphere. The fan and fan duct come as a module that is connected to the upstream and downstream ducts by two flexible couplings. Note carefully all other data given on the drawing. Neglect friction and any density changes in the flow.
- [6] (a) What are the absolute pressures at A and B? State any additional assumptions that you make to obtain your answers.
- [7] (b) Determine the force in the x direction, F_x , which the base of the fan exerts on the ground. Clearly indicate the direction of the force (to the right or the left).
- [4] (c) Determine the moment in the z direction, M_z , that the base of the fan exerts on the ground. Clearly indicate the direction of the moment (clockwise or counterclockwise).
- [3] (d) Supposed that the diffuser is removed such that the air exhausts to the atmosphere at plane B, will the power required to drive the fan increase, decrease or stay the same? Briefly explain your reasoning. Assume that the flow rate and the pressure at the inlet to the fan are the same for the two cases.
- [5] (e) If the fan has an efficiency of 70%, what shaft power, in horsepower, is required to drive the fan for the flow conditions shown in the drawing? Recall that 1 HP = 745 Watts.

[25]

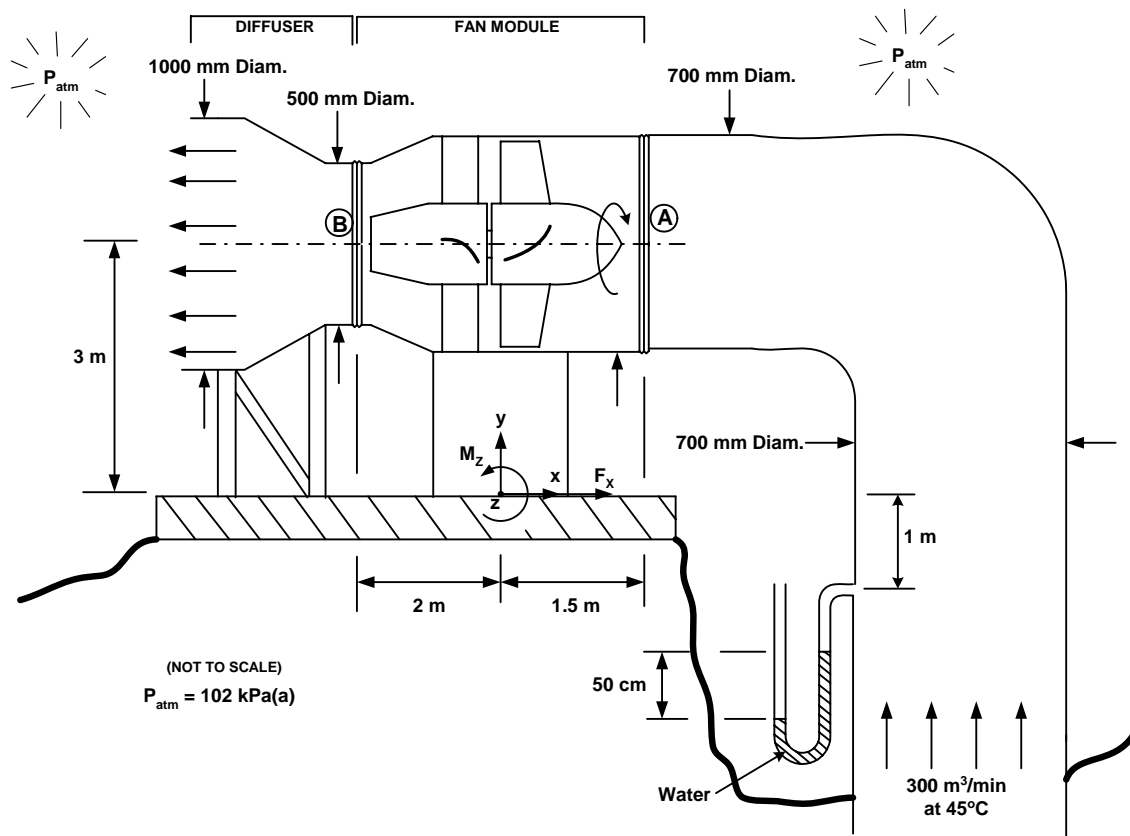

4. The drawing shows a nozzle used in fire fighting. The centrebody can be moved back and forth to adjust the flow rate of water and the spray pattern. For the centrebody in the position shown, the force in the thin stem is measured to be 3000 N. The jet of water has velocity of 30 m/s as it leaves the nozzle.

- [5] (a) Estimate the reading of the pressure gauge in kPa(g). State any assumptions made.
[13] (b) Assume that the pressure gauge reads +400 kPa(g) (Note: This is not the value you should have obtained in part (a)). Determine the force in the bolted joint. Indicate clearly whether the joint is in tension or compression.

[18]

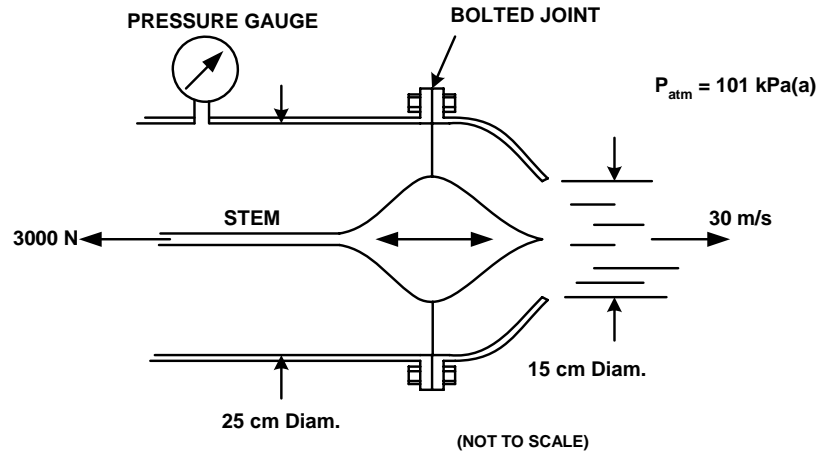

5. The drawing shows schematically a fire fighter spraying water onto a fire. A pump inside the truck provides pressurized water to the hose. The hose has an inside diameter of 10 cm and the outlet of the nozzle has an inside diameter of 5 cm. The hose is made of rubberized canvas and is estimated have a surface roughness of 1 mm on the inside surface.

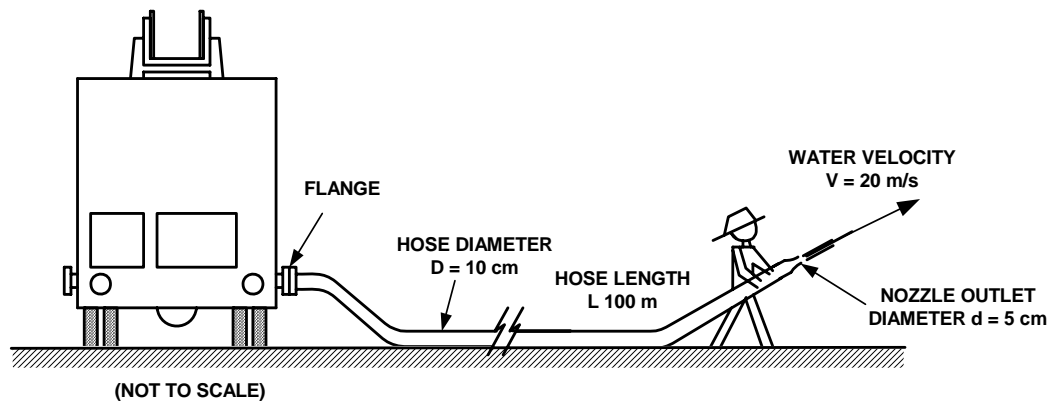

Co

consider initially the case where 100 m of hose is being used.

- [7] (a) Determine the gauge pressure in kPa(g) that the water must have at the flange at the truck to give the fireman a stream of water at the nozzle outlet that has a velocity of 20 m/s. Neglect minor (local) sources of losses. Also neglect any differences in elevation along the length of the hose. The water has a viscosity $\mu = 1.3 \times 10^{-3}$ Ns/m².
- [5] (b) The fire is being fought on a winter day and the ground is covered by ice. As a result, there is essentially no friction between the outside of the hose and the ground. The fireman resists all fluid dynamic forces that occur at the nozzle. However, he does not exert any forces on the hose itself. Estimate the tension force that will be present at the flanged joint where the hose is connected to the truck.

The fire is large and eventually the fireman needs to connect another 100 m of the same kind of hose to reach another part of the fire. The total length is thus 200 m of hose of 10 cm inside diameter.

- [7] (c) The pump at the truck still delivers the same pressure at the flange as calculated in part (a). What is the new velocity at the outlet of the nozzle under these conditions? Assume initially that the same value of friction factor applies as in the earlier calculations.
- [3] (d) Was the assumption of unchanged friction factor reasonable in part (c)? Support your answer quantitatively.

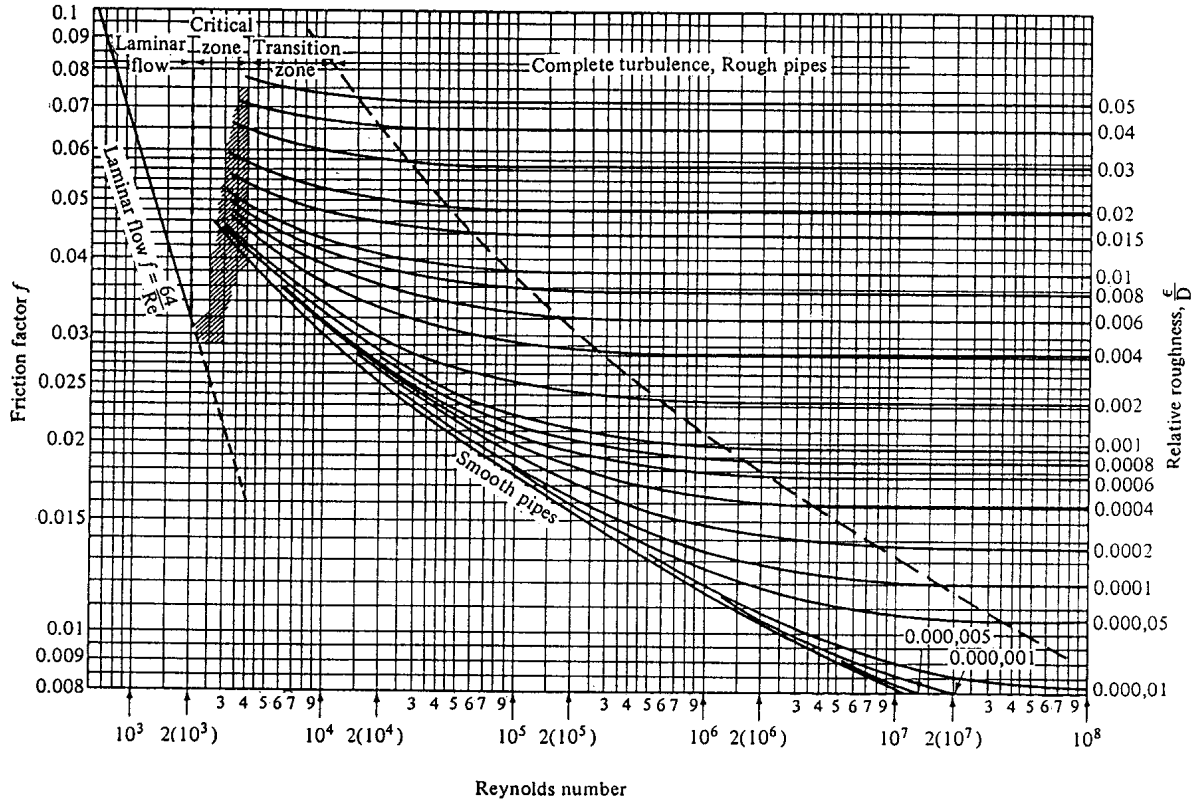

$$f = \frac{h_f}{\frac{LV^2}{D2g}}$$

Reynolds number:

$$Re = \frac{\rho VD}{\mu} = \frac{VD}{\nu}$$

CARLETON UNIVERSITY

Final
EXAMINATION
December 2005

DURATION: **3 HOURS**

No. of Students: **123**

Department Name & Course Number: **Mechanical & Aerospace Engineering, MAAE 2300A**

Instructor(s) **S.A. Sjolander**

AUTHORIZED MEMORANDA

1 sheet 8 1/2 x 11, both sides, any non-transmitting calculator

Students **MUST** count the number of pages in this examination question paper **before** beginning to write, and report any discrepancy immediately to a proctor. This question paper has **7** pages.

This examination question paper **MAY** be taken from the examination room.

ATTEMPT ALL QUESTIONS. THE VALUE OF EACH QUESTION IS GIVEN IN THE MARGIN. DRAW COMPLETE AND FULLY-LABELLED FREE-BODY DIAGRAMS OR CONTROL VOLUMES WHERE APPROPRIATE.

Geometric properties of common cross sections:

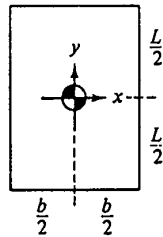

$$A = bL$$

$$I_{xx} = \frac{bL^3}{12}$$

$$I_{xy} = 0$$

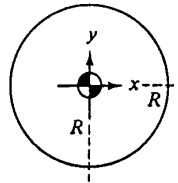

$$A = \pi R^2$$

$$I_{xx} = \frac{\pi R^4}{4}$$

$$I_{xy} = 0$$

Miscellaneous data:

Air: $R = 287 \text{ Nm/kgK}$
 $C_p = 1005 \text{ Nm/kgK}$
 $C_v = 716 \text{ Nm/kgK}$

Water: $\rho = 1000 \text{ kg/m}^3$
 $= 62.4 \text{ lb}_m/\text{ft}^3$
 $C_v = 4180 \text{ Nm/kgK}$

$$^{\circ}\text{R} = ^{\circ}\text{F} + 460$$

$$^{\circ}\text{K} = ^{\circ}\text{C} + 273$$

$$1 \text{ litre} = 1000 \text{ cm}^3$$

$$g = 32.174 \text{ ft/sec}^2$$

$$= 9.81 \text{ m/s}^2$$

$$1 \text{ HP} = 550 \text{ ft-lb}_f/\text{sec}$$

$$= 745 \text{ Nm/s}$$

See Page 7 for additional data.

1. The gate shown is 3 m wide in the horizontal direction. For the analysis, the mass of the gate and the cable that connects it to the 2500 kg counterweight can be neglected. There is no friction at the hinge H or at the pulley P. What is the depth d of the water in the reservoir for the conditions shown in the drawing?

[20]

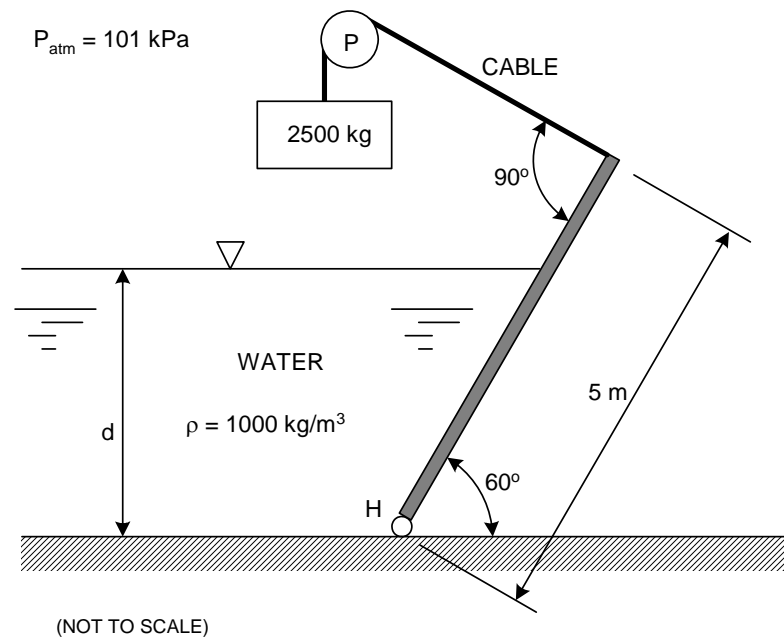

- 2 Determine the volume flow rate of water, in m^3/s , downward in the vertical contracting pipe shown in the drawing. State any simplifying assumptions made.

[15]

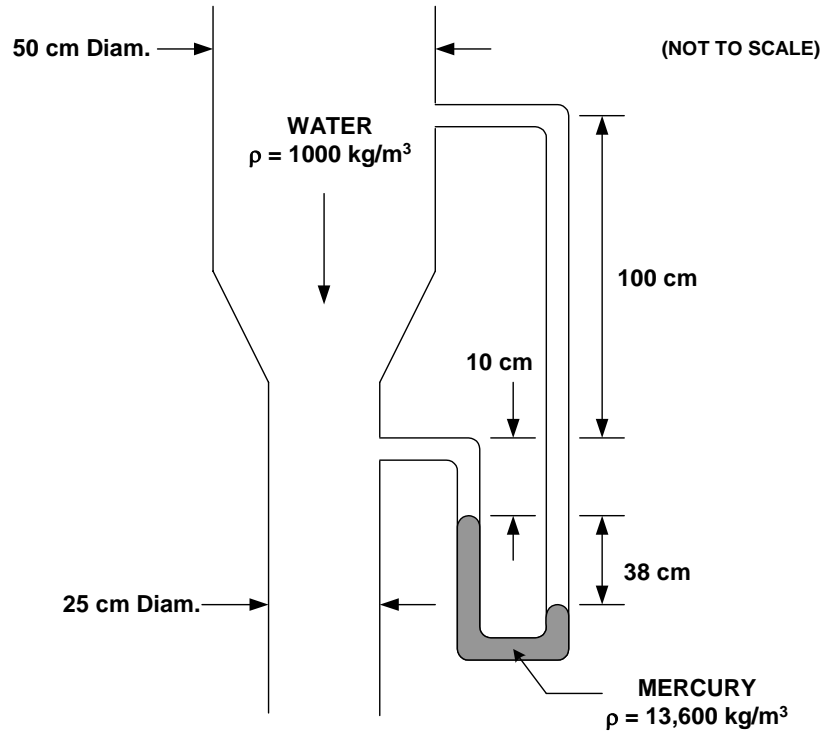

3. The snowblower shown in the drawing is being used clear a path in some wet snow which is 20 cm deep. The path is 1 m wide and the density of the snow is estimated to be 200 kg/m^3 . The snow is discharged horizontally, at right angles to the path, through the circular pipe shown. The outlet of the discharge pipe is at 1.5 m above the level of the ground. The machine is being pushed at a constant speed of 0.5 m/s along the path. State clearly any simplifying assumptions that you need to make to solve the individual parts of problem.

[4] (a) What is the discharge velocity of the snow, V_{out} , as it leaves the snowblower?

For the remaining parts of the problem, use a value of $V_{\text{out}} = 15 \text{ m/s}$. (**Note:** This is not necessarily the value you should have obtained in part (a)).

[8] (b) Estimate the force in the x direction, F_{push} , that is required to push the snowblower.

[5] (c) Estimate the sideways force that is exerted on the snowblower when it is operating. The rubber tires are intended to prevent the snowblower from sliding under the action of this sideways force. Assume that the layers of snow along the edges of the path do not apply any forces on the blower in the y direction. If the blower started to slide sideways, would it slide in the positive or negative y direction as shown in the drawing? Briefly explain briefly your reasoning.

[5] (d) Estimate the power, in horsepower, of the motor that must be installed in the machine to drive the rotor that “pumps” the snow. Assume that blower has an efficiency of 50%. Recall that 1 HP = 745 Watts.

[22]

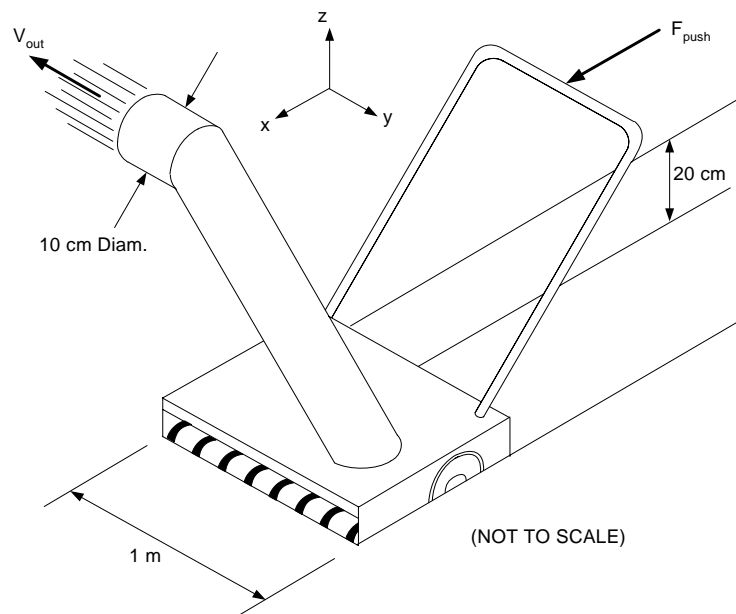

4. The drawing shows a section through a jet engine mounted on the wing of an aircraft. During landing, the thrust-reverser buckets deploy as shown and they deflect the exhaust flow partly forward with a velocity of 480 m/s relative to the engine. The thrust reverser buckets form a circle.

[8] (a) If the aircraft has a forward speed of 50 m/s, what force in the horizontal direction does the engine exert on the aircraft with the thrust reverser deployed as shown?

[10] (b) In the jet pipe (plane N as marked on the drawing) the flow has a cross-sectional area of 0.40 m^2 and the gases have a pressure of 20 kPa(g) and a velocity of 390 m/s . What is the force in the tailcone that supports the thrust-reverser buckets? Is the tailcone in compression or tension?

[18]

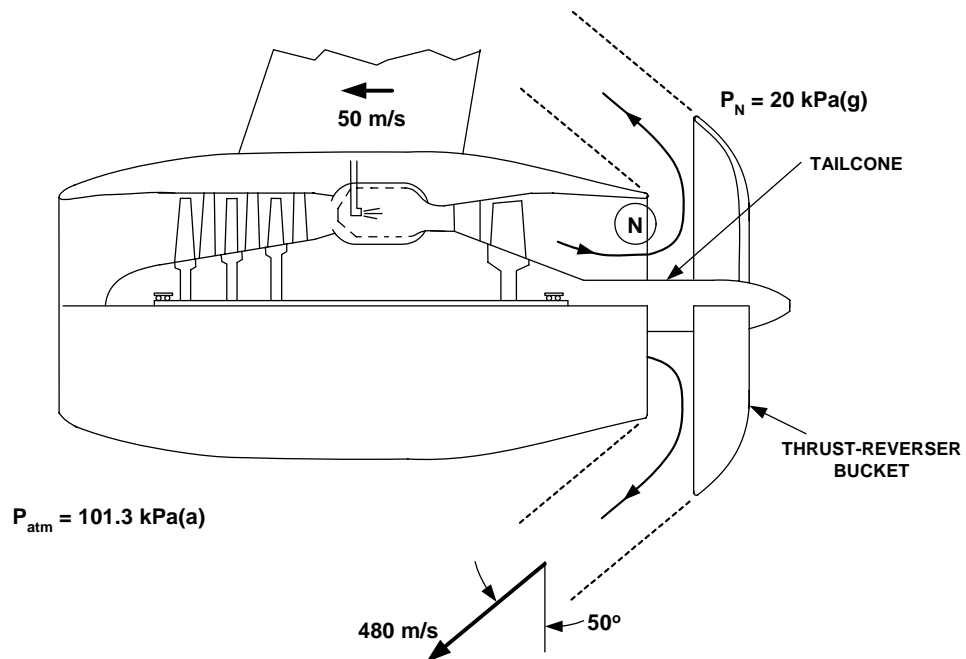

5. At an oil loading terminal, oil is stored in a large tank which is connected to the loading point by 200 m of 10 cm diameter piping. The free surface of the tank is 50 m above the loading point and the oil flows under the effects of gravity only. The oil must be delivered at the tanker truck with a pressure of 10 kPa(g). With age, the pipe has corroded and the increased roughness has caused the maximum flow rate in the pipe to drop to 100 m³/hr. The piping system has no fittings other than those shown in the drawing. The three elbows each have a loss coefficient $K = 0.3$.

[10] (a) What is the average roughness height, in mm, of the roughness on the inside surface of the corroded pipe?

For parts (b) and (c), assume that the average roughness height for the corroded pipe is 0.75 mm (**N.B.** This is not necessarily the value you should have obtained in part (a).)

[5] (b) What is the temperature change in the oil as it flows from the large tank to the truck pipe?

[10] (c) The terminal manager has asked you to increase the maximum available flow rate to 120 m³/hr and you suggest replacing some of the corroded pipe with new, smooth pipe of the same diameter. What length of pipe should be replaced with new, smooth pipe if the same delivery pressure is to be maintained?

[25]

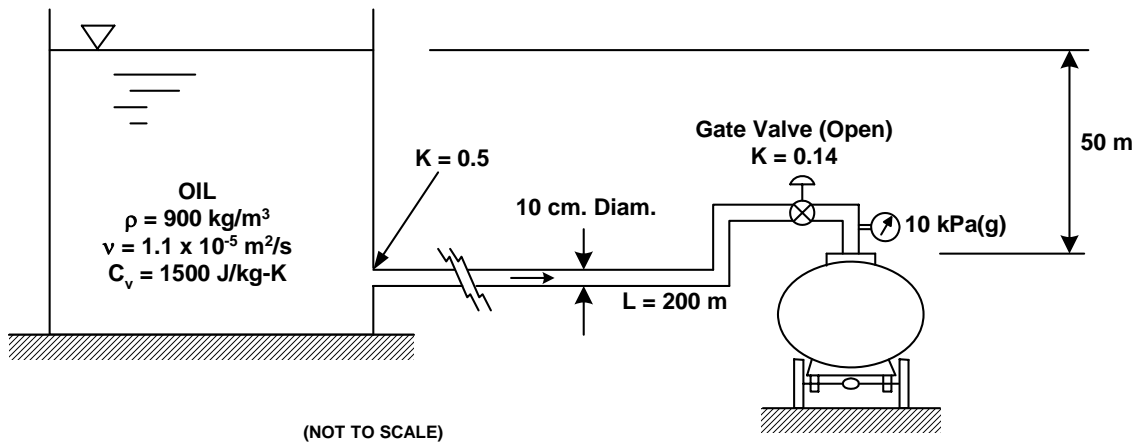

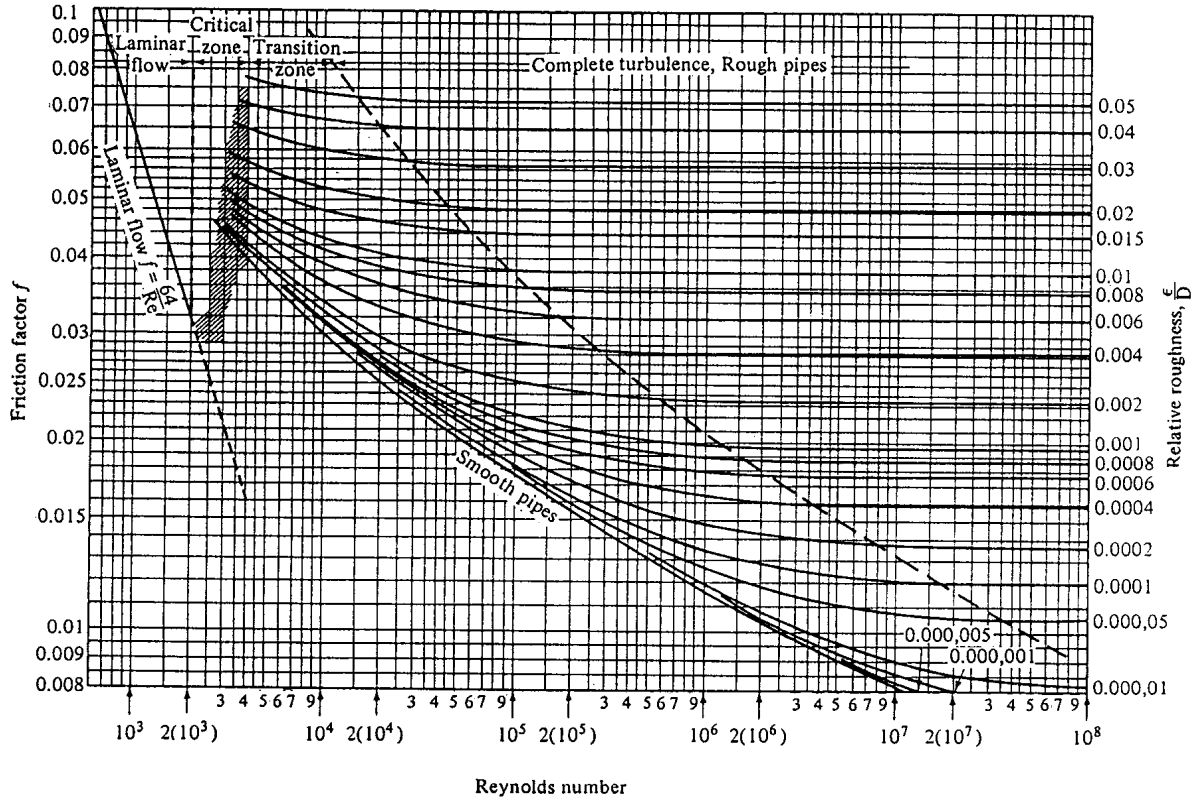

$$f = \frac{h_f}{\frac{L}{D} \frac{V^2}{2g}}$$

$$Reynolds Number = \frac{VD}{\nu}$$

CARLETON UNIVERSITY

Final
EXAMINATION
December 2003

DURATION: **3 HOURS**

No. of Students: **143**

Department Name & Course Number: **Mechanical & Aerospace Engineering, MAAE 2300A**

Instructor(s) **S.A. Sjolander**

AUTHORIZED MEMORANDA

1 sheet 8 1/2 x 11, both sides, any calculator

Students **MUST** count the number of pages in this examination question paper **before** beginning to write, and report any discrepancy immediately to a proctor. This question paper has **7** pages.

This examination question paper **MAY** be taken from the examination room.

ATTEMPT ALL QUESTIONS. THE VALUE OF EACH QUESTION IS GIVEN IN THE MARGIN. DRAW COMPLETE AND FULLY-LABELLED FREE-BODY DIAGRAMS OR CONTROL VOLUMES WHERE APPROPRIATE.

Geometric properties of common cross sections:

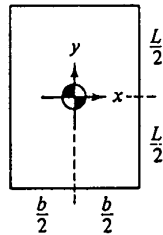

$$A = bL$$

$$I_{xx} = \frac{bL^3}{12}$$

$$I_{xy} = 0$$

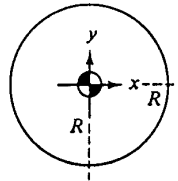

$$A = \pi R^2$$

$$I_{xx} = \frac{\pi R^4}{4}$$

$$I_{xy} = 0$$

Miscellaneous data:

Air: $R = 287 \text{ Nm/kgK}$
 $C_p = 1005 \text{ Nm/kgK}$
 $C_v = 716 \text{ Nm/kgK}$

Water: $\rho = 1000 \text{ kg/m}^3$
 $= 62.4 \text{ lb}_m/\text{ft}^3$
 $C_v = 4180 \text{ Nm/kgK}$

$$^{\circ}\text{R} = ^{\circ}\text{F} + 460$$

$$^{\circ}\text{K} = ^{\circ}\text{C} + 273$$

$$1 \text{ litre} = 1000 \text{ cm}^3$$

$$g = 32.174 \text{ ft/sec}^2$$

$$= 9.81 \text{ m/s}^2$$

$$1 \text{ HP} = 550 \text{ ft-lb}_f/\text{sec}$$

$$= 745 \text{ Nm/s}$$

See Page 7 for additional data.

1. The concrete dam shown in the drawing was built to create a water reservoir. After some years it is noticed that a layer of silt has accumulated on the bottom of the reservoir to a depth of 9 m. Concern has therefore arisen about the increased horizontal force which the dam must now support. You have been called in as a consultant to assess the situation.

You begin by examining some samples of the silt. You find that it is saturated with water and conclude that it will behave essentially as a very dense liquid. Your samples show that the density is about 2750 kg/m^3 .

- [15] (a) What is the magnitude and line of action of the net horizontal fluid force acting on a section of the dam which is 1 m wide?
- [5] (b) What net horizontal fluid force was acting on the same 1 m width when the dam was new? The surface of the water is 24 m above the base of the dam in both parts (a) and (b). You do not need to determine the line of action of the force in part (b).

[20]

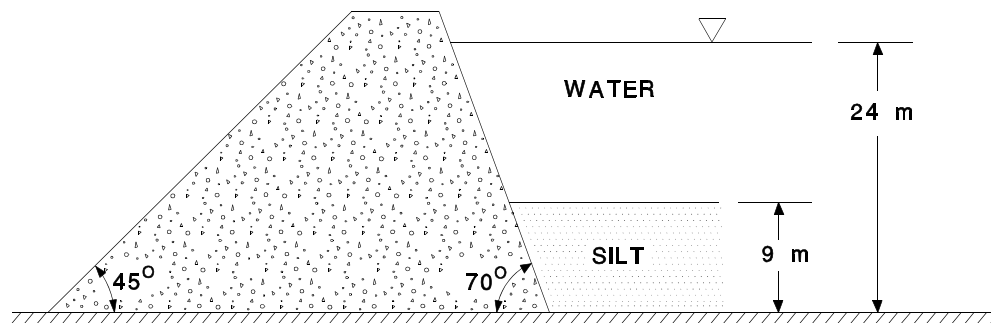

(NOT TO SCALE)

2. Water flows through the system shown in the drawing. For your analysis assume one-dimensional flow and neglect friction and all other losses in the system. Determine the height of water, H , in the tank if $h = 15$ cm for the mercury U-tube manometer.

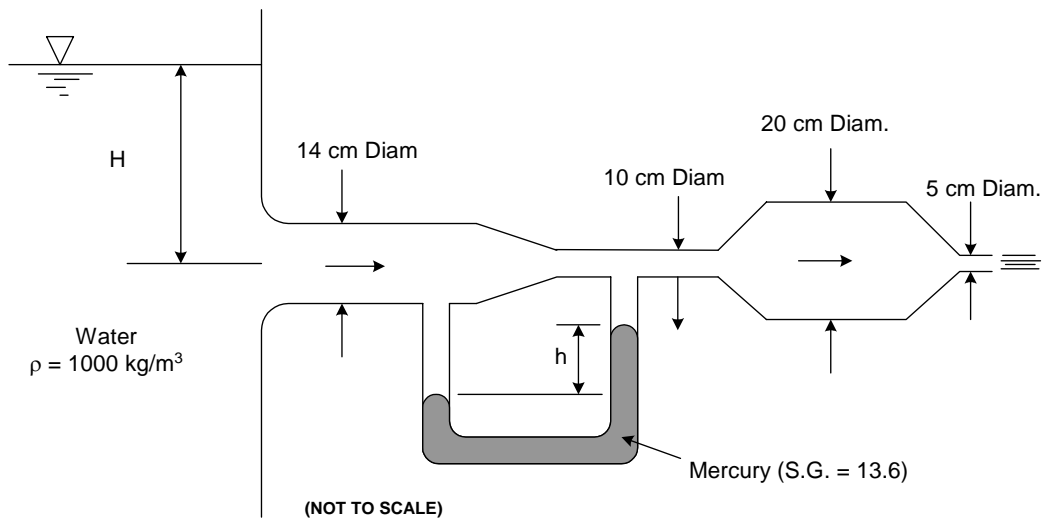

[20]

3. The drawing shows the spillway in a river. The spillway is located in a channel that is 10 m wide in the horizontal direction. In the analyses that follow, friction may be neglected.

[10] (a) For the depths of water shown before and after the spillway determine the flow rate of water, in m^3/s , that is flowing over the spillway.

[10] (b) Assuming a volume flow rate of $60 \text{ m}^3/\text{s}$ (**Note:** This is not necessarily the value you should have obtained in part (a)), and the same depths of water as shown in the drawing, determine the total horizontal force on the spillway.

[20]

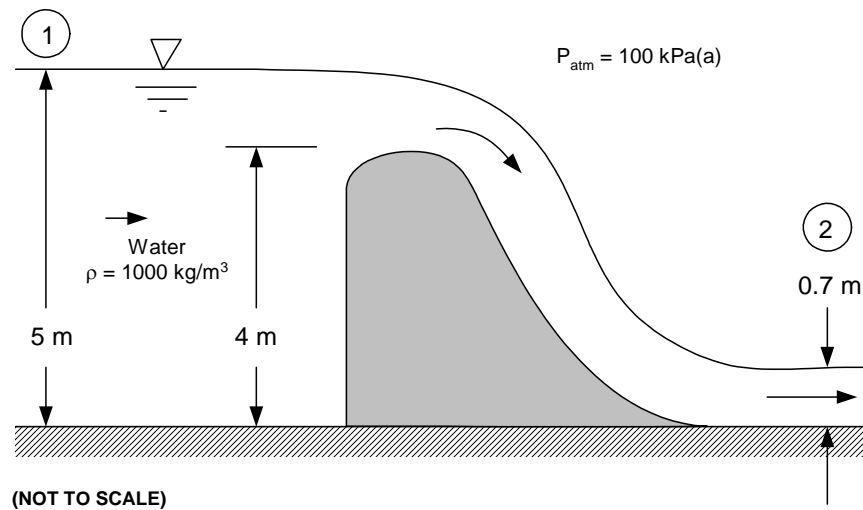

4. The gear box connecting the engine to the rotor is an important source of vibrations and maintenance problems in helicopters. The drawing shows a concept for a helicopter rotor that has no gear box. Instead, the hot exhaust gases from the gas turbine engine are piped to propelling nozzles at the tip of each rotor blade. The thrust developed by these nozzles provides the moment that drives the rotor. The flow entering the rotor ducting has no swirl. The flow leaves each nozzle in the tangential direction with a velocity relative to the nozzle of 800 m/s. At the nozzle exit, the gas has a static pressure of 200 kPa(a) and a temperature of 700 K. The hot gases may be assumed to have the same properties as air at these temperature and pressure conditions. If the rotor is rotating at 350 RPM, determine the moment about the axis of rotation of the rotor developed by this system. What is the effective power, in horsepower, developed by this drive system?

[20]

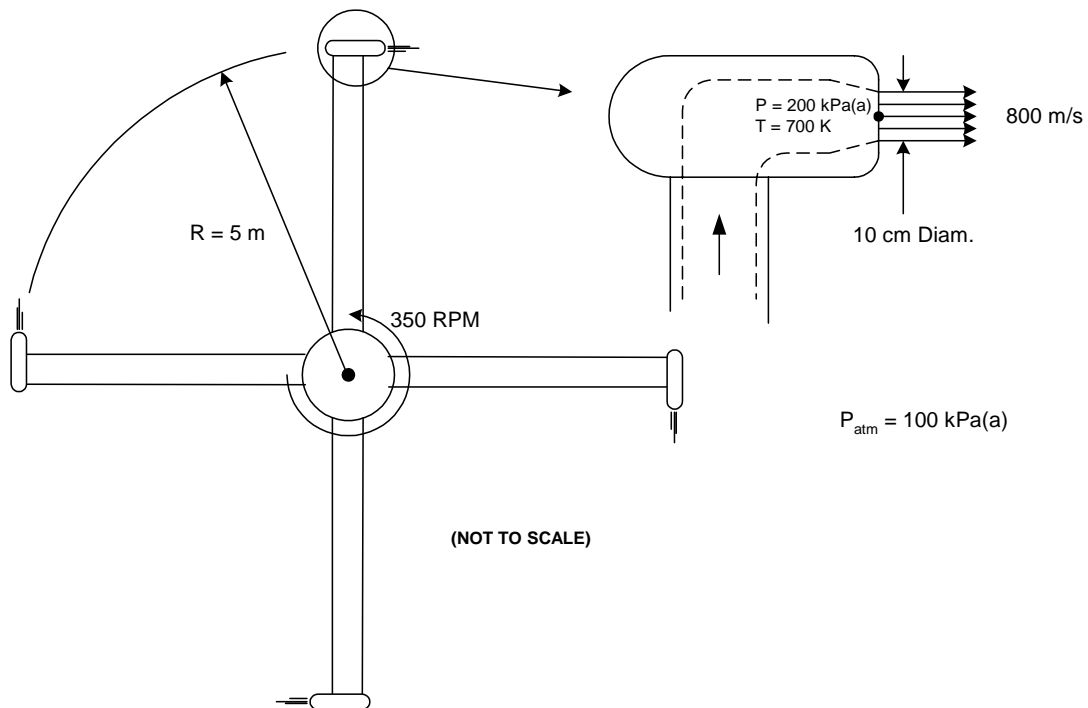

5. Gasoline (S.G. = 0.81) is to be pumped at 400 litres/s in a pipeline from point A to point B. Both of the tanks are open to the atmosphere. The pipe is to be laid on the surface of the ground, which has a high point at location C. The pipe includes two valves located at the inlet and outlet of the pipeline; in the fully open position, the valves have a loss coefficient $K = 2.0$. For the temperature conditions in the system, the gasoline has a viscosity $\nu = 4.26 \times 10^{-7} \text{ m}^2/\text{s}$ and a vapour pressure $P_v = 55.2 \text{ kPa(a)}$. Other relevant data are shown on the drawing.
- [10] (a) Determine the power of the electrical motor that must be installed to drive the pump (labelled P) if the pump has an efficiency of 80%.
- [6] (b) If the pressure in the gasoline goes below the vapour pressure, the gasoline will start to boil. This is undesirable. What is the maximum elevation allowable at location C if boiling of the gasoline is to be avoided?
- [4] (c) Suppose that the topography is such the elevation at point C is higher than the value you obtained in part (b). To avoid boiling, one solution would be to bury the pipeline such that point C was below the maximum allowable elevation. However, the customer wants to keep the pipeline above the ground. Also, the pump, valves and pipes have already been purchased. As the consulting engineer on this project you have been asked to recommend a solution. Suggest two possible modifications to the system that will allow the required flow rate to be delivered without boiling occurring. Your modifications should be as cheap as possible. Explain very briefly why each of your modifications will prevent boiling.

[20]

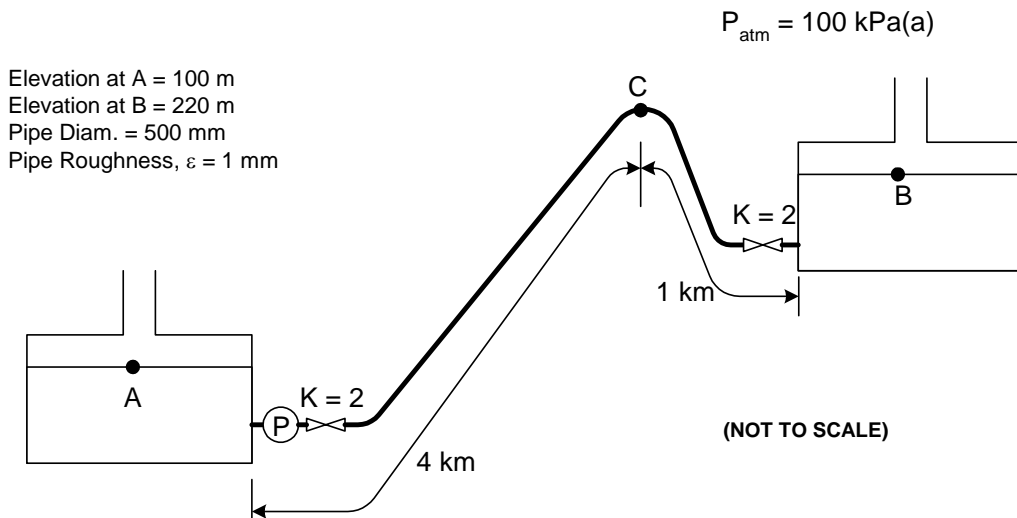

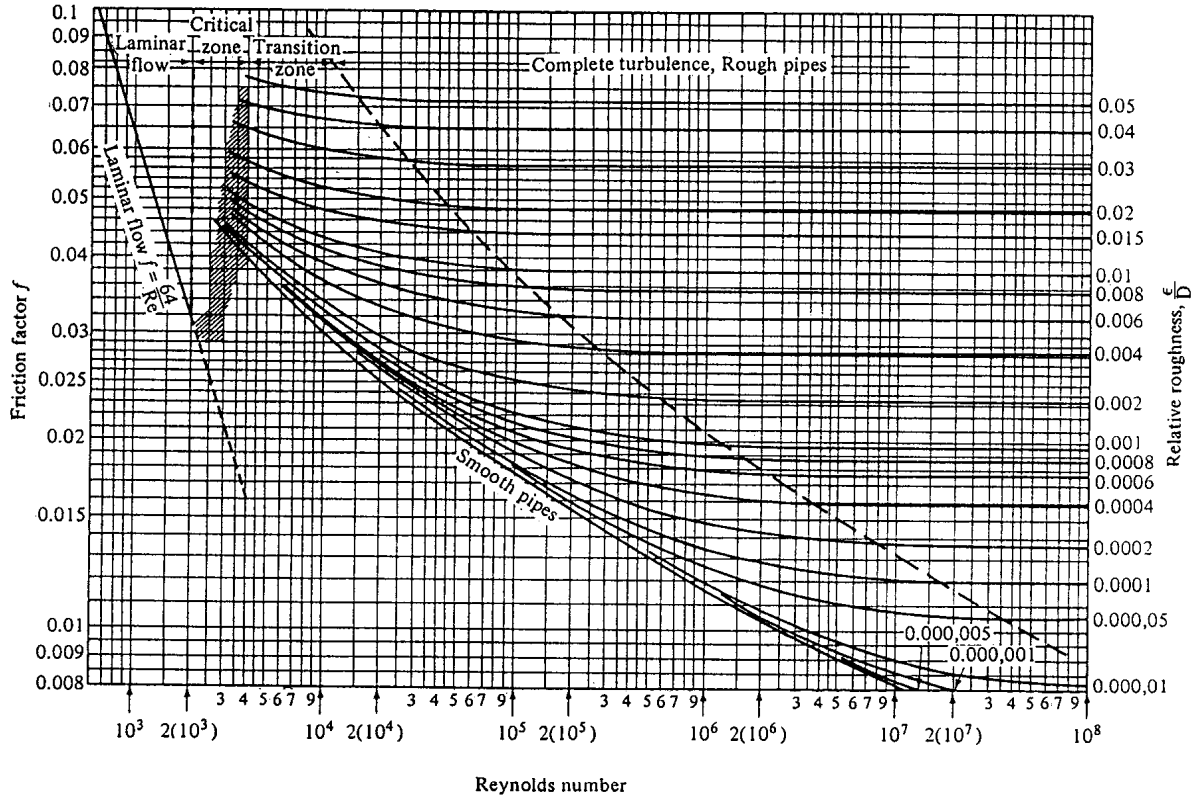

$$f = \frac{h_f}{\frac{L}{D} \frac{V^2}{2g}}$$

$$\text{Reynolds Number} = \frac{VD}{\nu}$$