

CVG2140 – Solution to Assignment No. 3 (Centroids & Moments of Inertia)

Problem 1: For the section shown below, find the position of the centroid.
 (Note: solve the problem by taking the origin at the point "O")

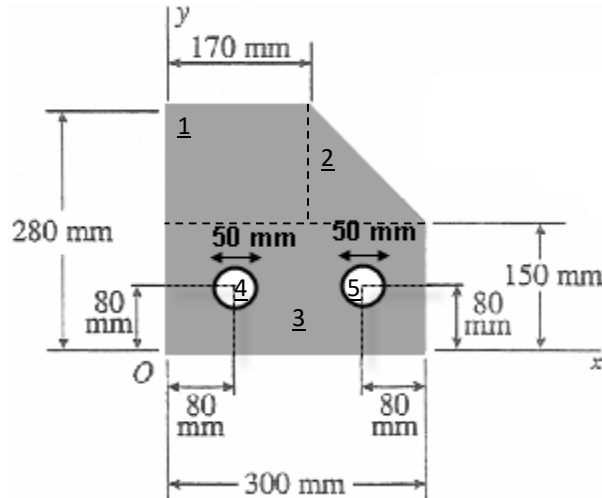

	A (mm ²)	\bar{x}_i (mm)	\bar{y}_i (mm)	$\bar{x}_i \cdot A_i$ (mm ³)	$\bar{y}_i \cdot A_i$ (mm ³)
A1	170×130=22,100	85	150+65=215	1,878,500	4,751,500
A2	130×130/2=8,450	170+(130/3)=213.3	150+(130/3)=193.3	1,802,385	1,633,385
A3	300×150=45,000	150	75	6,750,000	3,375,000
A4	-π×25 ² =-1,963.5	80	80	-157,080	-157,080
A5	-π×25 ² =-1,963.5	300-80=220	80	-431,970	-157,080
Σ	71,623			9,841,835	9,445,725

$$\bar{x} = \frac{\sum \bar{x}_i \cdot A_i}{\sum A_i} = \frac{9,841,835}{71,623} = 137.4 \text{ mm}$$

$$\bar{y} = \frac{\sum \bar{y}_i \cdot A_i}{\sum A_i} = \frac{9,445,725}{71,623} = 131.9 \text{ mm}$$

Problem 2: For the section shown below, find the moments of inertia I_x , I_y , J_o , I_{xy} with respect to a coordinate system located at the centroid. (Dimensions are in mm).

(a) Centroid

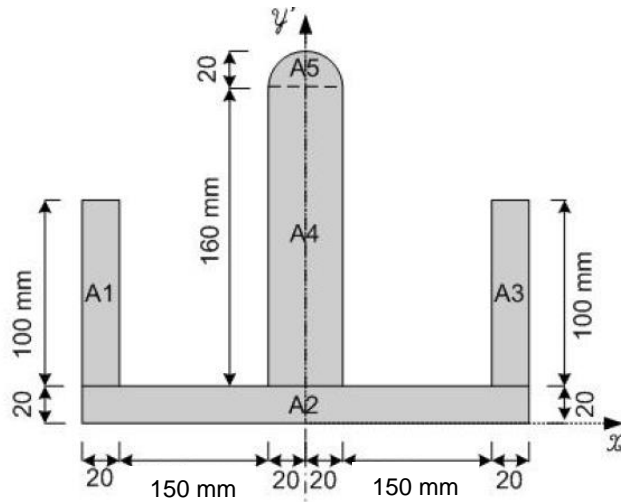

	A (mm ²)	\bar{x}_i (mm)	\bar{y}_i (mm)	$\bar{x}_i \cdot A_i$ (mm ³)	$\bar{y}_i \cdot A_i$ (mm ³)
A1	2,000	-180	70	-360,000	140,000
A2	7,600	0	10	0	76,000
A3	2,000	180	70	360,000	140,000
A4	6,400	0	100	0	640,000
A5	$\pi \times 20^2 / 2 = 628.3$	0	$180 + (4 \times 20 / 3\pi) = 188.5$	0	118,438
Σ	18,628.32			0	1,114,438.04

$$\bar{x} = \frac{\sum \bar{x}_i \cdot A_i}{\sum A_i} = \frac{0}{18,628.32} = 0 \text{ mm}$$

$$\bar{y} = \frac{\sum \bar{y}_i \cdot A_i}{\sum A_i} = \frac{1,114,438}{18,628.32} = 59.8 \text{ mm (from the bottom)}$$

(b) Moments of inertia

The parallel axis theorem, which refers to the centroidal axes of each area, will be used,

i.e., $I_x^i = I_{xc}^i + A^i (d_x^i)^2$.

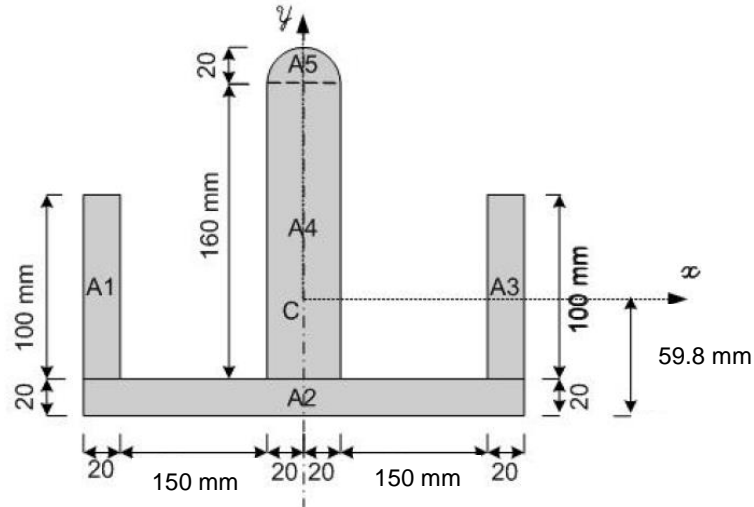

	I_{xc}^i (mm ⁴)	A (mm ²)	d_x^i (mm)	I_x^i (mm ⁴)
A1	1,666,667	2,000	10.2	1,874,747
A2	253,333	7,600	49.8	19,101,637
A3	1,666,667	2,000	10.2	1,874,747
A4	13,653,333	6,400	40.2	23,995,989
A5	17,568	$\pi \times 20^2 / 2 = 628.3$	128.7	10,424,841
Σ		18,628.32		57,271,961

	I_{yc}^i (mm ⁴)	A (mm ²)	d_y^i (mm)	I_y^i (mm ⁴)
A1	66,667	2,000	-180	64,866,667
A2	91,453,333	7,600	0	91,453,333
A3	66,667	2,000	180	64,866,667
A4	853,333	6,400	0	853,333
A5	62,832	$\pi \times 20^2 / 2 = 628.3$	0	62,832
Σ		18,628.32		222,102,832

$I_x = 57,271,961 \text{ mm}^4, I_y = 222,102,832 \text{ mm}^4$

$J_o = I_x + I_y = 57,271,961 + 222,102,832 = 279,374,793 \text{ mm}^4$

Since the figure is symmetric with respect to the y-axis, $I_{xy} = 0$.

Problem 3: Consider the section shown below. For a coordinate system located at the centroid, calculate the maximum and minimum values of the moments of inertia I_{max} and I_{min} (obtained by rotating the axes) and the corresponding angles.

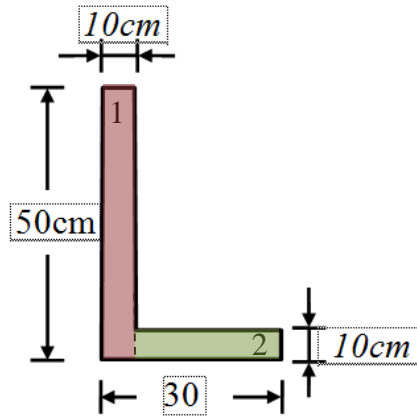

(a) Centroid

	A (cm ²)	\bar{x}_i (cm)	\bar{y}_i (cm)	$\bar{x}_i \cdot A_i$ (cm ³)	$\bar{y}_i \cdot A_i$ (cm ³)
A1	500	5	25	2,500	12,500
A2	200	20	5	4,000	1,000
Σ	700			6,500	13,500

$$\bar{x} = \frac{\sum \bar{x}_i \cdot A_i}{\sum A_i} = \frac{6,500}{700} = 9.3 \text{ cm (from the left)}$$

$$\bar{y} = \frac{\sum \bar{y}_i \cdot A_i}{\sum A_i} = \frac{13,500}{700} = 19.3 \text{ cm (from the bottom)}$$

(b) Moments of inertia with respect to centroidal axes

	I_{xc}^i (cm ⁴)	A (cm ²)	d_x^i (cm)	I_x^i (cm ⁴)
A1	104,167	500	5.7	120,412
A2	1,667	200	-14.3	42,565
Σ		700		162,976

	I_{yc}^i (cm ⁴)	A (cm ²)	d_y^i (cm)	I_y^i (cm ⁴)
A1	4,167	500	-4.3	13,412
A2	6,667	200	10.7	29,565
Σ		700		42,976

	I_{xyc}^i (cm ⁴)	A (cm ²)	d_x^i (cm)	d_y^i (cm)	I_{xy}^i (cm ⁴)
A1	0	500	5.7	-4.3	-12,255
A2	0	200	-14.3	10.7	-30,602
Σ		700			-42,857

(c) Principal moments of inertia and principal axes

$$\tan 2\theta = -\frac{I_{xy}}{I_x - I_y} = \frac{42,857}{162,976 - 42,976} = 0.714283$$

$$\theta = \frac{\tan^{-1}(0.714283)}{2} = 17.7^\circ \text{ (counterclockwise from x-axis)}$$

To find out the correspondence between principal moments of inertia and principal axes, the transformation equation is first used for $\theta = 17.7^\circ$:

$$\begin{aligned} I_{x'} &= \frac{I_{xc} + I_{yc}}{2} + \frac{I_{xc} - I_{yc}}{2} \cos(2 \times 17.7) - I_{xyc} \sin(2 \times 17.7) \\ &= \frac{162,976 + 42,976}{2} + \frac{162,976 - 42,976}{2} \cos(2 \times 17.7) - [-42,857 \times \sin(2 \times 17.7)] \\ &= 176,710 \text{ cm}^4 \end{aligned}$$

Then it is used for $\theta = 17.7^\circ + 90^\circ = 107.7^\circ$:

$$\begin{aligned} I_{x'} &= \frac{I_{xc} + I_{yc}}{2} + \frac{I_{xc} - I_{yc}}{2} \cos(2 \times 107.7) - I_{xyc} \sin(2 \times 107.7) \\ &= \frac{162,976 + 42,976}{2} + \frac{162,976 - 42,976}{2} \cos(2 \times 107.7) - [-42,857 \times \sin(2 \times 107.7)] \\ &= 29,242 \text{ cm}^4 \end{aligned}$$

Therefore,

$$I_{\max} = I_1 = 176,710 \text{ cm}^4 \text{ acting at } 17.7^\circ$$

$$I_{\min} = I_2 = 29,242 \text{ cm}^4 \text{ acting at } 107.7^\circ$$

