

PASS MOCK MIDTERM EXAM

– FOR PRACTICE ONLY –

Course: ECOR 1101 A

Facilitator: John Hammond

Dates and locations of mock exam take-up:

- Monday, October 19th from 6:00 PM – 8:00 PM in Southam Hall room 520
- Wednesday, October 21st from 6:00 PM – 8:00 PM in Patterson Hall room 133

It is **most beneficial** to you to write this mock midterm **UNDER EXAM CONDITIONS**. This means:

- Complete the mock midterm exam in **2 hours**.
- Work on your own.
- Keep your notes and textbook closed.
- Attempt every question.

After the time limit, go back over your work with a different colour or on a separate piece of paper and try to do the questions you are unsure of. Record your ideas in the margins to remind yourself of what you were thinking when you take it up at PASS.

The purpose of this mock exam is to give you practice answering questions in a timed setting and to help you to gauge which aspects of the course content you know well and which are in need of further development and review. Use this mock exam as a **learning tool** in preparing for the actual exam.

Please note:

- Come to the PASS session with your mock exam complete. There, you can work with other students to review your work.
- Often, there is not enough time to review the entire exam in the PASS session. Decide which questions you most want to review – the Facilitator may ask students to vote on which questions they want to discuss.
- Facilitators do not bring copies of the mock exam to the session. Please print out and complete the exam before you attend.
- **Facilitators do not produce or distribute an answer key for mock exams.** Facilitators help students to work together to compare and assess the answers they have. If you are not able to attend the PASS session, you can work alone or with others in the class.

Good Luck writing the Mock Exam!!

DISCLAIMER: PASS handouts are designed as a study aid only for use in PASS workshops. Handouts may contain errors, intentional or otherwise. It is up to the student to verify the information contained within.

PEER ASSISTED STUDY SESSIONS

Facil: John Hammond

Course: ECOR 1101 A

Mock Midterm Exam

Email: john.hammond@carleton.ca

Office: MacOdrum Library Room 408

Office Hour: Wednesdays 11:30am–12:30pm

- a) If the balloon is subjected to a net uplift of $F = 1000$ N, determine the magnitude of the tension developed in cables AB , AC and AD .¹
b) Determine the magnitude of the resultant force produced by the tensions in cables AB and AC .

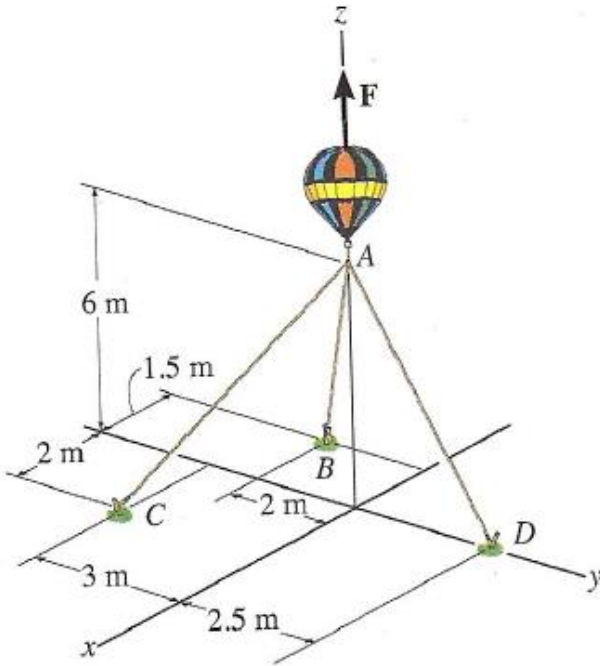

¹ Question and diagram modified from:

Hibbeler, R.C. *Engineering Mechanics: Statics and Dynamics*. Custom Edition for Carleton University. Upper Saddle River: Pearson Education, 2013. Print.

PEER ASSISTED STUDY SESSIONS

Facil: John Hammond

Course: ECOR 1101 A

Mock Midterm Exam

Email: john.hammond@carleton.ca

Office: MacOdrum Library Room 408

Office Hour: Wednesdays 11:30am–12:30pm

2. a) Determine the moment of $\mathbf{F} = \{50\mathbf{i} - 30\mathbf{j} + 60\mathbf{k}\}$ lb about B .²
b) Determine the moment of $\mathbf{F} = \{50\mathbf{i} - 30\mathbf{j} + 60\mathbf{k}\}$ lb about the AB axis and express the result as a Cartesian vector.

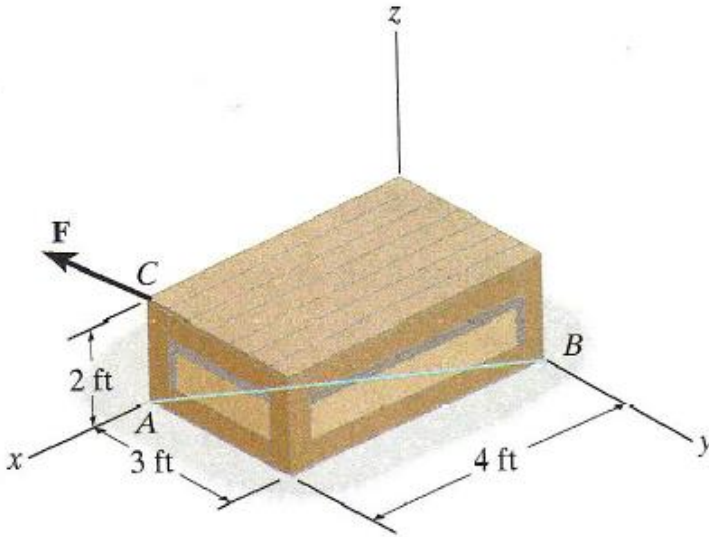

² Question and diagram modified from:

Hibbeler, R.C. *Engineering Mechanics: Statics and Dynamics*. Custom Edition for Carleton University. Upper Saddle River: Pearson Education, 2013. Print.

DISCLAIMER: PASS worksheets are designed as a study aid for use in PASS workshops only. Worksheets may contain errors, intentional or otherwise. It is up to the student to verify the information contained within.

PEER ASSISTED STUDY SESSIONS

Facil: John Hammond

Course: ECOR 1101 A

Mock Midterm Exam

Email: john.hammond@carleton.ca

Office: MacOdrum Library Room 408

Office Hour: Wednesdays 11:30am–12:30pm

3. a) Determine the location of the centroids of the two shapes below (triangle and curved region).
b) Determine the location of the centroid of the entire shaded area below.

