

CARLETON UNIVERSITY

**FINAL  
EXAMINATION  
December 2015**

DURATION: 3 HOURS

No. of Students: 110

**AUTHORIZED MEMORANDA: textbooks, course notes, calculators and laptop computers are allowed.**

Department Name & Course Number: **Mechanical & Aerospace Engineering MAAE 4102 A**  
Instructor(s) A. Artemev

Students **MUST** count the number of pages in this examination paper **before** beginning to write, and report any discrepancy immediately to a proctor. The Examination paper has 3 pages.

In addition to this Examination paper, students require: an examination booklet yes X no      
a Scantron sheet yes     no X

This examination paper **MAY** be taken from the examination room.

1. (15 % of final grade) A 4 m long beam (Fig. 1 a) with a triangular shaped cross-section (Fig. 1 b) is rigidly built at one end and simply supported at the other end. The beam is made of the material with yield strength  $\sigma_y = 350 \text{ MPa}$ , Young's modulus  $E = 210 \text{ GPa}$  and Poisson's ratio  $\nu = 0.31$ . The beam is loaded by the distributed load with the intensity linearly rising from 0 at one end to  $w$  at the other end. a) Calculate the moment  $M_p$  of the fully plastic beam cross-section. b) Calculate the  $w$  value corresponding to the onset of the plastic collapse.

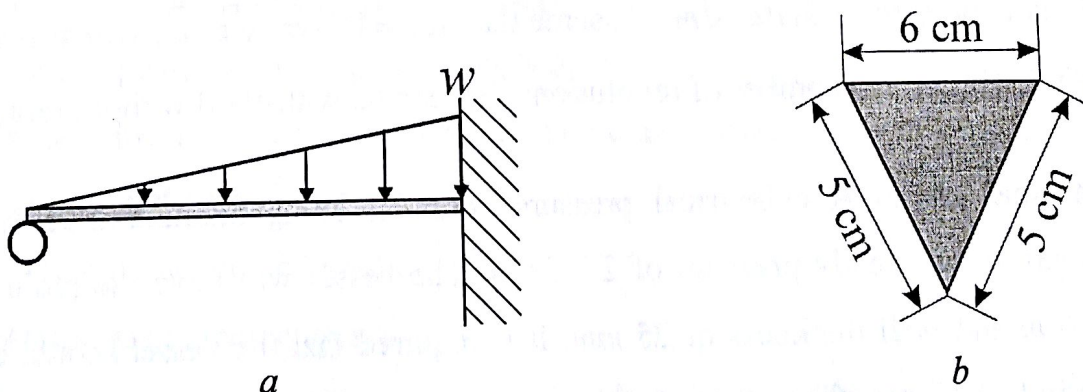

Fig. 1

2. (15 % of final grade) A double ended DCB specimen (Fig. 2) consists of two adhesively bonded thin plates. The plates have the thicknesses  $h_1=2 \text{ mm}$  and  $h_2=3 \text{ mm}$ . The width of the plates is  $w=20 \text{ mm}$ . The length of each plate is  $L=250 \text{ mm}$ . The upper plate has Young's modulus of  $40 \text{ GPa}$  and the lower plate has Young's modulus of  $60 \text{ GPa}$ . The plates are bonded by an adhesive with Young's modulus of  $2.5 \text{ GPa}$ , tensile strength of  $80 \text{ MPa}$  and toughness of  $3.1 \text{ kJ/m}^2$ . The specimen contains a crack in the adhesive between the plates with the length of  $a=40 \text{ mm}$  located at the center of the specimen. It is loaded by the forces applied along the center section of the specimen as shown in Fig. 2. Estimate the load value at the beginning of the fracture (assume that the specimen has linear elastic behavior).

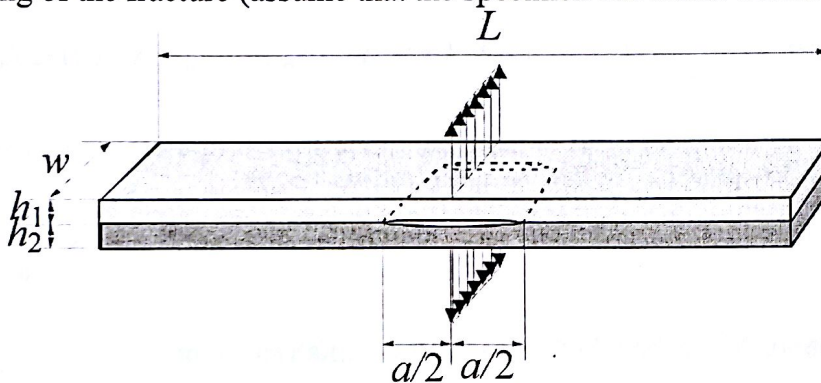

Fig. 2 Double ended DCB specimen.

3. (15 % of final grade) A thin walled rotating shaft is subjected to a torque and a bending load. The torque produces the shear stress of  $120 \text{ MPa}$ . The bending load produces the normal stress varying through the shaft cross-section from  $-60 \text{ MPa}$  to  $60 \text{ MPa}$ . The shaft may contain through cracks of unknown orientation with the length of up to  $2.5 \text{ mm}$ . The shaft material has  $\sigma_y = 380 \text{ MPa}$ ,  $E = 70 \text{ GPa}$ ,  $\nu = 0.315$ ,  $K_{Ic} = 35 \text{ MPa} \cdot \sqrt{\text{m}}$ . The crack growth is approximately described by the Paris law with  $A = 6.9 \cdot 10^{-12} \text{ m/cycle}$  and  $m = 3$ , when  $\Delta K$  is expressed in  $\text{MPa} \cdot \sqrt{\text{m}}$ . Assume that  $K_I = 1.1 \cdot \sigma \cdot \sqrt{\pi \cdot a}$ , where  $a$  is the crack half length. Estimate the number of revolutions that can be withstood without failure.
4. (15 % of final grade) A cylindrical pressure vessel is being manufactured to contain a corrosive gas at the steady pressure of  $2.0 \text{ MPa}$ . The vessel will have the radius of  $1.2 \text{ m}$ , length of  $6 \text{ m}$  and wall thickness of  $25 \text{ mm}$ . It is required that the vessel should contain gas for the period of 12 months without leaking or any other form of failure. The material used for the manufacturing of the vessel has the yield strength  $\sigma_y = 780 \text{ MPa}$ , and fracture

toughness  $K_{Ic} = 70 \text{ MPa} \cdot \sqrt{\text{m}}$ . The rate of the stress corrosion crack growth in the environment of the gas which will be contained in the vessel is described by the SCC constant  $D = 6.5 \cdot 10^{-5} \text{ yr}^{-1} \cdot \text{MPa}^{-2}$ . Determine if the proof testing (testing by using an excessive pressure of the inert gas in the vessel in the as-manufactured state) can be used to ensure that the quality of the manufactured vessel satisfies the requirements. Assume that  $K_I = \sigma \cdot \sqrt{\pi \cdot a}$ , where  $a$  is the crack depth.

5. (10 % of final grade)

- a) List several material properties which are affected by the grain size. Give examples of positive and negative effects on material properties that can be produced by the increase in the grain size.
- b) A thin composite plate is attached by adhesive bonding to a wide and stiff supporting beam made of an alloy. It was found that the failure in this system occurs by peeling the plate from the beam. Which of the following changes in the materials can improve the overall strength of the system?
  - (a) An alloy with a higher yield stress
  - (b) an alloy with a higher toughness
  - (c) an alloy with a higher Young's modulus
  - (d) an adhesive with a higher yield stress
  - (e) an adhesive with a higher toughness
  - (f) an adhesive with a higher Young's modulus
  - (g) a stronger composite
  - (h) a composite with a higher toughness
  - (i) a composite with a higher Young's modulus.
- c) Briefly describe how the type of the dominant creep mechanism can be affected by the:
  - decrease in the grain size;
  - increase in the applied stress;
  - increase in the temperature.
- d) Briefly describe two examples of negative effects of metallic impurity elements on the alloy properties.