



uOttawa

L'Université canadienne
Canada's university

GNG1105/1505
Final Exam

December 12th, 2014.

Profs: A. Skaff, G. Doudak, P. Richer, P. Dumond and A. Ahmed

Closed book examination. Only non-programmable calculators are allowed. All other electronic devices are not allowed. All questions are of equal value.

- 1- The triangular horizontal plate ABC ($AB=AC$) is being held in by a ball and socket joint at A and two cables (BD and CD), as shown. The weight of the plate is 500N which is acting at its centroid G.

- Draw the free body diagram of the plate,
- Write, in vector form, the tension in cables BD, CD, and the 500N weight,
- Calculate the tensions in cables BD and CD and the components of the reaction at point A.

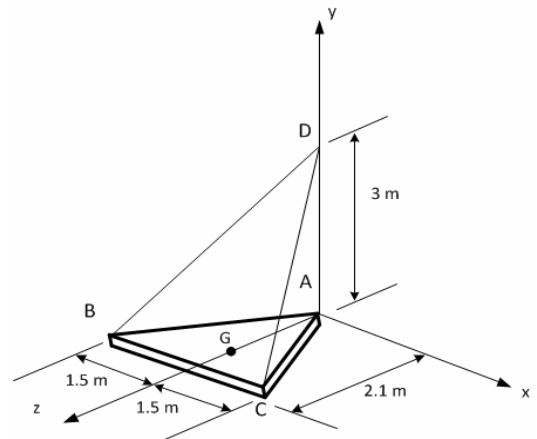

- 2- The sketch shows a pin-jointed truss loaded with a single force $P=10\text{kN}$, as shown.

- Identify all zero-force members,
- Find the reactions at supports A and B,
- Find the forces in members AB and AC by the “joints method”, and specify if they are in tension or compression,
- Find the forces in members EG, EF, and DF by the “sections method” and specify if they are in tension or compression.

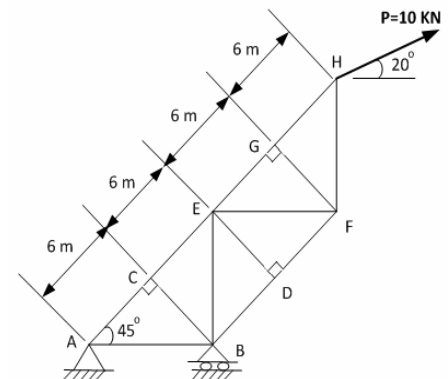

- 3- Block A has a mass of 20kg and block B has a mass of 10kg. Both are pin-connected by two slender rods of negligible weight at point C, as shown in the diagram.

If the coefficient of static friction between the two blocks and the horizontal surface is 0.20, calculate the largest value of P for equilibrium to be maintained.

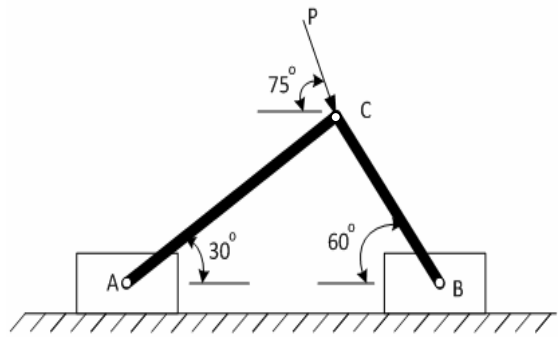

- 4- A football player starts from rest and runs from point A to point B, 20m away, with a constant acceleration. He arrives at point B in 2.5 second where he kicks the football with a velocity V_0 making a 30° angle with the horizontal (as shown in the diagram).
- Find the acceleration and the velocity of the player at point B.
 - If the distance from point B to point C, where the ball hits the ground, is 60m, find the value of V_0 and the maximum height, h , of the football above the ground.

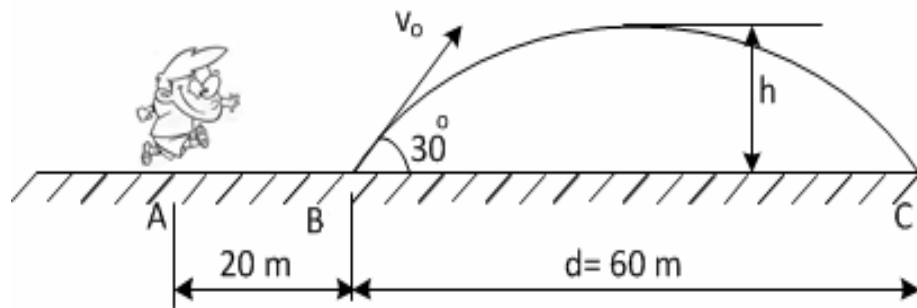

Useful Equations

$$x = x_0 + vt$$

$$v = v_0 + at$$

$$x = x_0 + v_0t + \frac{1}{2}at^2$$

$$v^2 = v_0^2 + 2a(x - x_0)$$

$$\sum \vec{F} = m\vec{a}$$

$$\sum \vec{F}_x = m\vec{a}_x, \quad \sum \vec{F}_y = m\vec{a}_y, \quad \sum \vec{F}_z = m\vec{a}_z$$

Centroid

