

CHAPTER 3

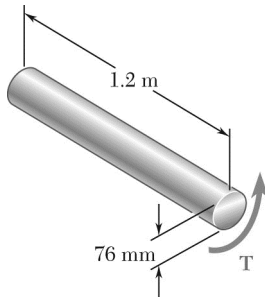

PROBLEM 3.1

(a) Determine the maximum shearing stress caused by a $4.6\text{-kN} \cdot \text{m}$ torque T in the 76-mm -diameter shaft shown. (b) Solve part *a*, assuming that the solid shaft has been replaced by a hollow shaft of the same outer diameter and of 24-mm inner diameter.

SOLUTION

(a) Solid shaft:

$$c = \frac{d}{2} = 38 \text{ mm} = 0.038 \text{ m}$$

$$J = \frac{\pi}{2} c^4 = \frac{\pi}{2} (0.038)^4 = 3.2753 \times 10^{-6} \text{ m}^4$$

$$\tau = \frac{Tc}{J} = \frac{(4.6 \times 10^3)(0.038)}{3.2753 \times 10^{-6}} = 53.4 \times 10^6 \text{ Pa}$$

$$\tau = 53.4 \text{ MPa} \quad \blacktriangleleft$$

(b) Hollow shaft:

$$c_2 = \frac{d_o}{2} = 0.038 \text{ m}$$

$$c_1 = \frac{1}{2} d_i = 12 \text{ mm} = 0.012 \text{ m}$$

$$J = \frac{\pi}{2} (c_2^4 - c_1^4) = \frac{\pi}{2} (0.038^4 - 0.012^4) = 3.2428 \times 10^{-6} \text{ m}^4$$

$$\tau = \frac{Tc}{J} = \frac{(4.6 \times 10^3)(0.038)}{3.2428 \times 10^{-6}} = 53.9 \times 10^6 \text{ Pa}$$

$$\tau = 53.9 \text{ MPa} \quad \blacktriangleleft$$

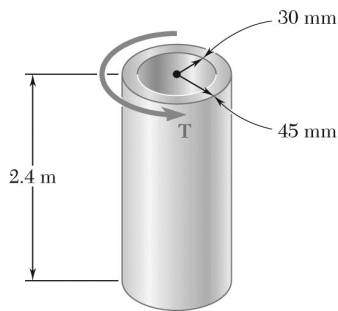

PROBLEM 3.2

(a) Determine the torque T that causes a maximum shearing stress of 45 MPa in the hollow cylindrical steel shaft shown. (b) Determine the maximum shearing stress caused by the same torque T in a solid cylindrical shaft of the same cross-sectional area.

SOLUTION

(a) Given shaft:

$$J = \frac{\pi}{2}(c_2^4 - c_1^4)$$

$$J = \frac{\pi}{2}(45^4 - 30^4) = 5.1689 \times 10^6 \text{ mm}^4 = 5.1689 \times 10^{-6} \text{ m}^4$$

$$\tau = \frac{Tc}{J} \quad T = \frac{J\tau}{c}$$

$$T = \frac{(5.1689 \times 10^{-6})(45 \times 10^6)}{45 \times 10^{-3}} = 5.1689 \times 10^3 \text{ N} \cdot \text{m}$$

$$T = 5.17 \text{ kN} \cdot \text{m} \quad \blacktriangleleft$$

(b) Solid shaft of same area:

$$A = \pi(c_2^2 - c_1^2) = \pi(45^2 - 30^2) = 3.5343 \times 10^3 \text{ mm}^2$$

$$\pi c^2 = A \quad \text{or} \quad c = \sqrt{\frac{A}{\pi}} = 33.541 \text{ mm}$$

$$J = \frac{\pi}{2}c^4, \quad \tau = \frac{Tc}{J} = \frac{2T}{\pi c^3}$$

$$\tau = \frac{(2)(5.1689 \times 10^3)}{\pi(0.033541)^3} = 87.2 \times 10^6 \text{ Pa}$$

$$\tau = 87.2 \text{ MPa} \quad \blacktriangleleft$$

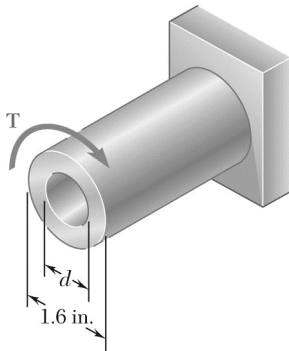

PROBLEM 3.3

Knowing that $d = 1.2$ in., determine the torque T that causes a maximum shearing stress of 7.5 ksi in the hollow shaft shown.

SOLUTION

$$c_2 = \frac{1}{2}d_2 = \left(\frac{1}{2}\right)(1.6) = 0.8 \text{ in.} \quad c = 0.8 \text{ in.}$$

$$c_1 = \frac{1}{2}d_1 = \left(\frac{1}{2}\right)(1.2) = 0.6 \text{ in.}$$

$$J = \frac{\pi}{2}(c_2^4 - c_1^4) = \frac{\pi}{2}(0.8^4 - 0.6^4) = 0.4398 \text{ in}^4$$

$$\tau_{\max} = \frac{Tc}{J}$$

$$T = \frac{J\tau_{\max}}{c} = \frac{(0.4398)(7.5)}{0.8}$$

$$T = 4.12 \text{ kip} \cdot \text{in} \quad \blacktriangleleft$$

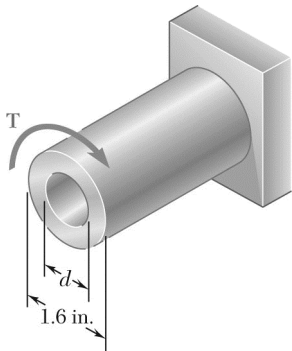

PROBLEM 3.4

Knowing that the internal diameter of the hollow shaft shown is $d = 0.9$ in., determine the maximum shearing stress caused by a torque of magnitude $T = 9$ kip \cdot in.

SOLUTION

$$c_2 = \frac{1}{2}d_2 = \left(\frac{1}{2}\right)(1.6) = 0.8 \text{ in.} \quad c = 0.8 \text{ in.}$$

$$c_1 = \frac{1}{2}d_1 = \left(\frac{1}{2}\right)(0.9) = 0.45 \text{ in.}$$

$$J = \frac{\pi}{2}(c_2^4 - c_1^4) = \frac{\pi}{2}(0.8^4 - 0.45^4) = 0.5790 \text{ in}^4$$

$$\tau_{\max} = \frac{Tc}{J} = \frac{(9)(0.8)}{0.5790} \quad \tau_{\max} = 12.44 \text{ ksi} \blacktriangleleft$$

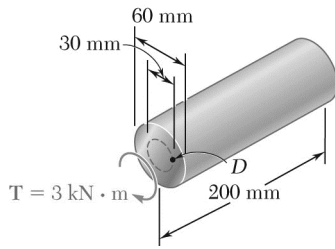

PROBLEM 3.5

A torque $T = 3 \text{ kN} \cdot \text{m}$ is applied to the solid bronze cylinder shown. Determine (a) the maximum shearing stress, (b) the shearing stress at point D which lies on a 15-mm-radius circle drawn on the end of the cylinder, (c) the percent of the torque carried by the portion of the cylinder within the 15 mm radius.

SOLUTION

$$(a) \quad c = \frac{1}{2}d = 30 \text{ mm} = 30 \times 10^{-3} \text{ m}$$

$$J = \frac{\pi}{2}c^4 = \frac{\pi}{2}(30 \times 10^{-3})^4 = 1.27235 \times 10^{-6} \text{ m}^4$$

$$T = 3 \text{ kN} = 3 \times 10^3 \text{ N}$$

$$\tau_m = \frac{Tc}{J} = \frac{(3 \times 10^3)(30 \times 10^{-3})}{1.27235 \times 10^{-6}} = 70.736 \times 10^6 \text{ Pa}$$

$$\tau_m = 70.7 \text{ MPa} \quad \blacktriangleleft$$

$$(b) \quad \rho_D = 15 \text{ mm} = 15 \times 10^{-3} \text{ m}$$

$$\tau_D = \frac{\rho_D}{c} \tau = \frac{(15 \times 10^{-3})(70.736 \times 10^6)}{(30 \times 10^{-3})}$$

$$\tau_D = 35.4 \text{ MPa} \quad \blacktriangleleft$$

$$(c) \quad \tau_D = \frac{T_D \rho_D}{J_D} \quad T_D = \frac{J_D \tau_D}{\rho_D} = \frac{\pi}{2} \rho_D^3 \tau_D$$

$$T_D = \frac{\pi}{2} (15 \times 10^{-3})^3 (35.368 \times 10^6) = 187.5 \text{ N} \cdot \text{m}$$

$$\frac{T_D}{T} \times 100\% = \frac{187.5}{3 \times 10^3} (100\%) = 6.25\%$$

$$6.25\% \quad \blacktriangleleft$$

PROBLEM 3.6

(a) Determine the torque that can be applied to a solid shaft of 20-mm diameter without exceeding an allowable shearing stress of 80 MPa. (b) Solve Part a, assuming that the solid shaft has been replaced by a hollow shaft of the same cross-sectional area and with an inner diameter equal to half of its own outer diameter.

SOLUTION

(a) Solid shaft: $c = \frac{1}{2}d = \frac{1}{2}(0.020) = 0.010 \text{ m}$

$$J = \frac{\pi}{2}c^4 = \frac{\pi}{2}(0.010)^4 = 15.7080 \times 10^{-9} \text{ m}^4$$

$$T = \frac{J\tau_{\max}}{c} = \frac{(15.7080 \times 10^{-9})(80 \times 10^6)}{0.010} = 125.664 \quad T = 125.7 \text{ N} \cdot \text{m} \blacktriangleleft$$

(b) Hollow shaft: Same area as solid shaft.

$$A = \pi(c_2^2 - c_1^2) = \pi \left[c_2^2 - \left(\frac{1}{2}c_2 \right)^2 \right] = \frac{3}{4}\pi c_2^2 = \pi c^2$$

$$c_2 = \frac{2}{\sqrt{3}}c = \frac{2}{\sqrt{3}}(0.010) = 0.0115470 \text{ m}$$

$$c_1 = \frac{1}{2}c_2 = 0.0057735 \text{ m}$$

$$J = \frac{\pi}{2}(c_2^4 - c_1^4) = \frac{\pi}{2}(0.0115470^4 - 0.0057735^4) = 26.180 \times 10^{-9} \text{ m}^4$$

$$T = \frac{\tau_{\max} J}{c_2} = \frac{(80 \times 10^6)(26.180 \times 10^{-9})}{0.0115470} = 181.38 \quad T = 181.4 \text{ N} \cdot \text{m} \blacktriangleleft$$

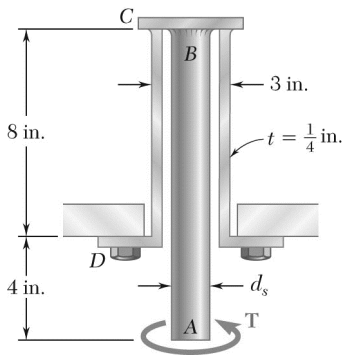

PROBLEM 3.7

The solid spindle AB has a diameter $d_s = 1.5$ in. and is made of a steel with an allowable shearing stress of 12 ksi, while sleeve CD is made of a brass with an allowable shearing stress of 7 ksi. Determine the largest torque T that can be applied at A .

SOLUTION

Analysis of solid spindle AB : $c = \frac{1}{2} d_s = 0.75$ in.

$$\tau = \frac{Tc}{J} \quad T = \frac{J\tau}{c} = \frac{\pi}{2} \tau c^3$$

$$T = \frac{\pi}{2} (12 \times 10^3)(0.75)^3 = 7.95 \times 10^3 \text{ lb} \cdot \text{in}$$

Analysis of sleeve CD : $c_2 = \frac{1}{2} d_o = \frac{1}{2} (3) = 1.5$ in.

$$c_1 = c_2 - t = 1.5 - 0.25 = 1.25 \text{ in.}$$

$$J = \frac{\pi}{2} (c_2^4 - c_1^4) = \frac{\pi}{2} (1.5^4 - 1.25^4) = 4.1172 \text{ in}^4$$

$$T = \frac{J\tau}{c_2} = \frac{(4.1172)(7 \times 10^3)}{1.5} = 19.21 \times 10^3 \text{ lb} \cdot \text{in}$$

The smaller torque governs: $T = 7.95 \times 10^3 \text{ lb} \cdot \text{in}$

$$T = 7.95 \text{ kip} \cdot \text{in} \quad \blacktriangleleft$$

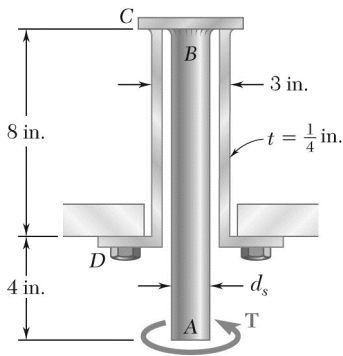

PROBLEM 3.8

The solid spindle AB is made of a steel with an allowable shearing stress of 12 ksi, and sleeve CD is made of a brass with an allowable shearing stress of 7 ksi. Determine (a) the largest torque T that can be applied at A if the allowable shearing stress is not to be exceeded in sleeve CD , (b) the corresponding required value of the diameter d_s of spindle AB .

SOLUTION

(a) Analysis of sleeve CD :

$$c_2 = \frac{1}{2}d_o = \frac{1}{2}(3) = 1.5 \text{ in.}$$

$$c_1 = c_2 - t = 1.5 - 0.25 = 1.25 \text{ in.}$$

$$J = \frac{\pi}{2}(c_2^4 - c_1^4) = \frac{\pi}{2}(1.5^4 - 1.25^4) = 4.1172 \text{ in}^4$$

$$T = \frac{J\tau}{c_2} = \frac{(4.1172)(7 \times 10^3)}{1.5} = 19.21 \times 10^3 \text{ lb} \cdot \text{in}$$

$$T = 19.21 \text{ kip} \cdot \text{in} \blacktriangleleft$$

(b) Analysis of solid spindle AB :

$$\tau = \frac{Tc}{J}$$

$$\frac{J}{c} = \frac{\pi}{2}c^3 = \frac{T}{\tau} = \frac{19.21 \times 10^3}{12 \times 10^3} = 1.601 \text{ in}^3$$

$$c = \sqrt[3]{\frac{(2)(1.601)}{\pi}} = 1.006 \text{ in.} \quad d_s = 2c$$

$$d = 2.01 \text{ in.} \blacktriangleleft$$

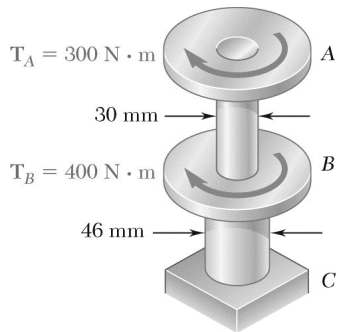

PROBLEM 3.9

The torques shown are exerted on pulleys *A* and *B*. Knowing that both shafts are solid, determine the maximum shearing stress (a) in shaft *AB*, (b) in shaft *BC*.

SOLUTION

(a) Shaft *AB*:

$$T_{AB} = 300 \text{ N} \cdot \text{m}, \quad d = 0.030 \text{ m}, \quad c = 0.015 \text{ m}$$

$$\begin{aligned} \tau_{\max} &= \frac{Tc}{J} = \frac{2T}{\pi c^3} = \frac{(2)(300)}{\pi(0.015)^3} \\ &= 56.588 \times 10^6 \text{ Pa} \end{aligned}$$

$$\tau_{\max} = 56.6 \text{ MPa} \quad \blacktriangleleft$$

(b) Shaft *BC*:

$$T_{BC} = 300 + 400 = 700 \text{ N} \cdot \text{m}$$

$$d = 0.046 \text{ m}, \quad c = 0.023 \text{ m}$$

$$\begin{aligned} \tau_{\max} &= \frac{Tc}{J} = \frac{2T}{\pi c^3} = \frac{(2)(700)}{\pi(0.023)^3} \\ &= 36.626 \times 10^6 \text{ Pa} \end{aligned}$$

$$\tau_{\max} = 36.6 \text{ MPa} \quad \blacktriangleleft$$

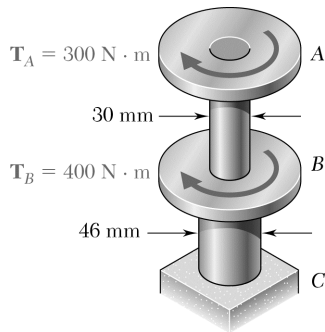

PROBLEM 3.10

In order to reduce the total mass of the assembly of Prob. 3.9, a new design is being considered in which the diameter of shaft BC will be smaller. Determine the smallest diameter of shaft BC for which the maximum value of the shearing stress in the assembly will not increase.

SOLUTION

Shaft AB :

$$T_{AB} = 300 \text{ N} \cdot \text{m}, \quad d = 0.030 \text{ m}, \quad c = 0.015 \text{ m}$$

$$\begin{aligned} \tau_{\max} &= \frac{Tc}{J} = \frac{2T}{\pi c^3} = \frac{(2)(300)}{\pi(0.015)^3} \\ &= 56.588 \times 10^6 \text{ Pa} = 56.6 \text{ MPa} \end{aligned}$$

Shaft BC :

$$T_{BC} = 300 + 400 = 700 \text{ N} \cdot \text{m}$$

$$d = 0.046 \text{ m}, \quad c = 0.023 \text{ m}$$

$$\begin{aligned} \tau_{\max} &= \frac{Tc}{J} = \frac{2T}{\pi c^3} = \frac{(2)(700)}{\pi(0.023)^3} \\ &= 36.626 \times 10^6 \text{ Pa} = 36.6 \text{ MPa} \end{aligned}$$

The largest stress ($56.588 \times 10^6 \text{ Pa}$) occurs in portion AB .

Reduce the diameter of BC to provide the same stress.

$$\begin{aligned} T_{BC} = 700 \text{ N} \cdot \text{m} \quad \tau_{\max} &= \frac{Tc}{J} = \frac{2T}{\pi c^3} \\ c^3 &= \frac{2T}{\pi \tau_{\max}} = \frac{(2)(700)}{\pi(56.588 \times 10^6)} = 7.875 \times 10^{-6} \text{ m}^3 \\ c &= 19.895 \times 10^{-3} \text{ m} \quad d = 2c = 39.79 \times 10^{-3} \text{ m} \end{aligned}$$

$$d = 39.8 \text{ mm} \quad \blacktriangleleft$$

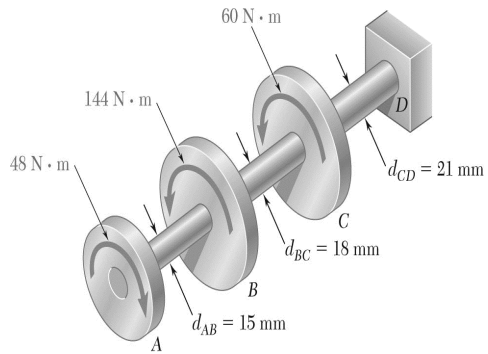

PROBLEM 3.11

Knowing that each portion of the shafts AB , BC , and CD consist of a solid circular rod, determine (a) the shaft in which the maximum shearing stress occurs, (b) the magnitude of that stress.

SOLUTION

Shaft AB :

$$T = 48 \text{ N} \cdot \text{m}$$

$$c = \frac{1}{2}d = 7.5 \text{ mm} = 0.0075 \text{ m}$$

$$\tau_{\max} = \frac{Tc}{J} = \frac{2T}{\pi c^3}$$

$$\tau_{\max} = \frac{(2)(48)}{\pi(0.0075)^3} = 72.433 \text{ MPa}$$

Shaft BC :

$$T = -48 + 144 = 96 \text{ N} \cdot \text{m}$$

$$c = \frac{1}{2}d = 9 \text{ mm} \quad \tau_{\max} = \frac{Tc}{J} = \frac{2T}{\pi c^3} = \frac{(2)(96)}{\pi(0.009)^3} = 83.835 \text{ MPa}$$

Shaft CD :

$$T = -48 + 144 + 60 = 156 \text{ N} \cdot \text{m}$$

$$c = \frac{1}{2}d = 10.5 \text{ mm} \quad \tau_{\max} = \frac{Tc}{J} = \frac{2T}{\pi c^3} = \frac{(2)(156)}{\pi(0.0105)^3} = 85.79 \text{ MPa}$$

Answers:

(a) shaft CD (b) 85.8 MPa ◀

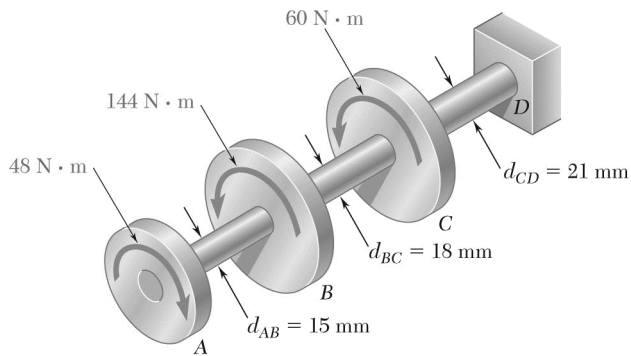

PROBLEM 3.12

Knowing that an 8-mm-diameter hole has been drilled through each of the shafts AB , BC , and CD , determine (a) the shaft in which the maximum shearing stress occurs, (b) the magnitude of that stress.

SOLUTION

Hole: $c_1 = \frac{1}{2}d_1 = 4 \text{ mm}$

Shaft AB : $T = 48 \text{ N} \cdot \text{m}$
 $c_2 = \frac{1}{2}d_2 = 7.5 \text{ mm}$

$$J = \frac{\pi}{2}(c_2^4 - c_1^4) = \frac{\pi}{2}(0.0075^4 - 0.004^4) = 4.5679 \times 10^{-9} \text{ m}^4$$

$$\tau_{\max} = \frac{Tc_2}{J} = \frac{(48)(0.0075)}{4.5679 \times 10^{-9}} = 78.810 \text{ MPa}$$

Shaft BC : $T = -48 + 144 = 96 \text{ N} \cdot \text{m}$ $c_2 = \frac{1}{2}d_2 = 9 \text{ mm}$

$$J = \frac{\pi}{2}(c_2^4 - c_1^4) = \frac{\pi}{2}(0.009^4 - 0.004^4) = 9.904 \times 10^{-9} \text{ m}^4$$

$$\tau_{\max} = \frac{Tc_2}{J} = \frac{(96)(0.009)}{9.904 \times 10^{-9}} = 87.239 \text{ MPa}$$

Shaft CD : $T = -48 + 144 + 60 = 156 \text{ N} \cdot \text{m}$ $c_2 = \frac{1}{2}d_2 = 10.5 \text{ mm}$

$$J = \frac{\pi}{2}(c_2^4 - c_1^4) = \frac{\pi}{2}(0.0105^4 - 0.004^4) = 18.691 \times 10^{-9} \text{ m}^4$$

$$\tau_{\max} = \frac{Tc_2}{J} = \frac{(156)(0.0105)}{18.691 \times 10^{-9}} = 87.636 \text{ MPa}$$

Answers:

(a) shaft CD

(b) 87.6 MPa ◀

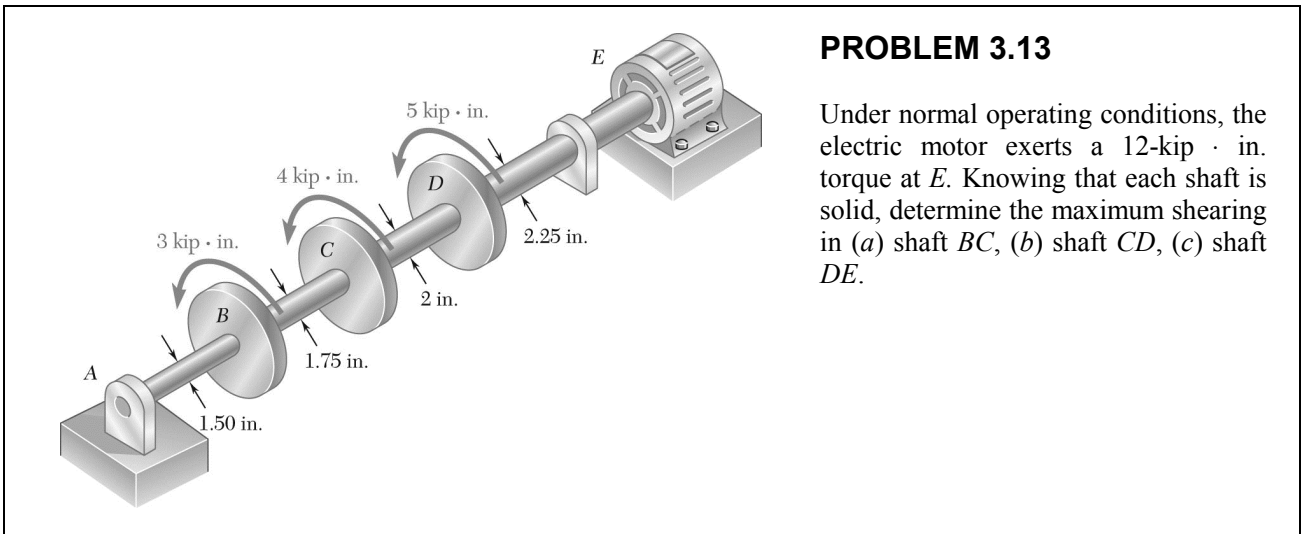

PROBLEM 3.13

Under normal operating conditions, the electric motor exerts a 12-kip · in. torque at *E*. Knowing that each shaft is solid, determine the maximum shearing in (a) shaft *BC*, (b) shaft *CD*, (c) shaft *DE*.

SOLUTION

(a) Shaft BC:

From free body shown:

$$T_{BC} = 3 \text{ kip} \cdot \text{in}$$

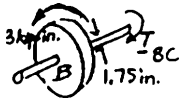

$$\tau = \frac{Tc}{J} = \frac{Tc}{\frac{\pi}{2}c^4} = \frac{2}{\pi} \frac{T}{c^3} \tag{1}$$

$$\tau = \frac{2}{\pi} \frac{3 \text{ kip} \cdot \text{in}}{\left(\frac{1}{2} \times 1.75 \text{ in.}\right)^3} \quad \tau = 2.85 \text{ ksi} \blacktriangleleft$$

(b) Shaft CD:

From free body shown:

$$T_{CD} = 3 + 4 = 7 \text{ kip} \cdot \text{in}$$

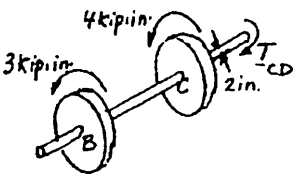

From Eq. (1):

$$\tau = \frac{2}{\pi} \frac{T}{c^3} = \frac{2}{\pi} \frac{7 \text{ kip} \cdot \text{in}}{(1 \text{ in.})^3} \quad \tau = 4.46 \text{ ksi} \blacktriangleleft$$

(c) Shaft DE:

From free body shown:

$$T_{DE} = 12 \text{ kip} \cdot \text{in}$$

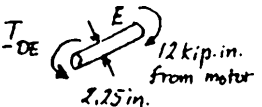

From Eq. (1):

$$\tau = \frac{2}{\pi} \frac{T}{c^3} = \frac{2}{\pi} \frac{12 \text{ kip} \cdot \text{in}}{\left(\frac{1}{2} \times 2.25 \text{ in.}\right)^3} \quad \tau = 5.37 \text{ ksi} \blacktriangleleft$$

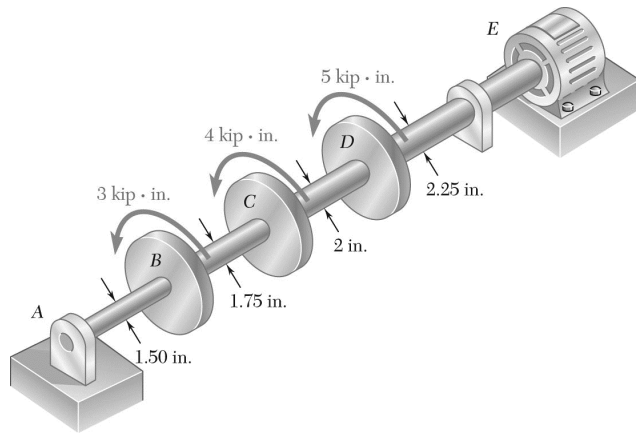

PROBLEM 3.14

Solve Prob. 3.13, assuming that a 1-in.-diameter hole has been drilled into each shaft.

PROBLEM 3.13 Under normal operating conditions, the electric motor exerts a 12-kip · in. torque at *E*. Knowing that each shaft is solid, determine the maximum shearing in (a) shaft *BC*, (b) shaft *CD*, (c) shaft *DE*.

SOLUTION

(a) Shaft *BC*:



From free body shown: $T_{BC} = 3 \text{ kip} \cdot \text{in}$

$$c_2 = \frac{1}{2}(1.75) = 0.875 \text{ in.} \quad c_1 = \frac{1}{2}(1) = 0.5 \text{ in.}$$

$$J = \frac{\pi}{2}(c_2^4 - c_1^4) = \frac{\pi}{2}(0.875^4 - 0.5^4) = 0.82260 \text{ in}^4$$

$$\tau = \frac{Tc}{J} = \frac{(3 \text{ kip} \cdot \text{in})(0.875 \text{ in.})}{0.82260 \text{ in}^4} \quad \tau = 3.19 \text{ ksi} \quad \blacktriangleleft$$

(b) Shaft *CD*:

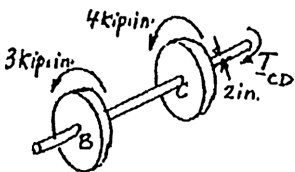

From free body shown: $T_{CD} = 3 + 4 = 7 \text{ kip} \cdot \text{in}$

$$c_2 = \frac{1}{2}(2.0) = 1.0 \text{ in.}$$

$$J = \frac{\pi}{2}(c_2^4 - c_1^4) = \frac{\pi}{2}(1.0^4 - 0.5^4) = 1.47262 \text{ in}^4$$

$$\tau = \frac{Tc}{J} = \frac{(7 \text{ kip} \cdot \text{in})(1.0 \text{ in.})}{1.47262 \text{ in}^4} \quad \tau = 4.75 \text{ ksi} \quad \blacktriangleleft$$

(c) Shaft *DE*:

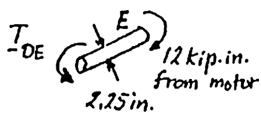

From free body shown: $T_{DE} = 12 \text{ kip} \cdot \text{in}$

$$c_2 = \frac{2.25}{2} = 1.125 \text{ in.}$$

$$J = \frac{\pi}{2}(c_2^4 - c_1^4) = \frac{\pi}{2}(1.125^4 - 0.5^4) = 2.4179 \text{ in}^4$$

$$\tau = \frac{Tc}{J} = \frac{(12 \text{ kip} \cdot \text{in})(1.125 \text{ in.})}{2.4179 \text{ in}^4} \quad \tau = 5.58 \text{ ksi} \quad \blacktriangleleft$$

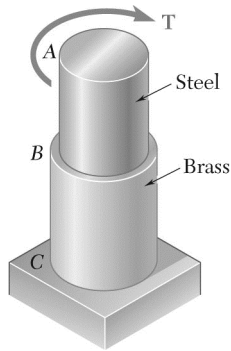

PROBLEM 3.15

The allowable shearing stress is 15 ksi in the 1.5-in.-diameter steel rod AB and 8 ksi in the 1.8-in.-diameter brass rod BC . Neglecting the effect of stress concentrations, determine the largest torque that can be applied at A .

SOLUTION

$$\tau_{\max} = \frac{Tc}{J}, \quad J = \frac{\pi}{2}c^4, \quad T = \frac{\pi}{2}c^3\tau_{\max}$$

Rod AB :

$$\tau_{\max} = 15 \text{ ksi} \quad c = \frac{1}{2}d = 0.75 \text{ in.}$$

$$T = \frac{\pi}{2}(0.75)^3(15) = 9.94 \text{ kip} \cdot \text{in}$$

Rod BC :

$$\tau_{\max} = 8 \text{ ksi} \quad c = \frac{1}{2}d = 0.90 \text{ in.}$$

$$T = \frac{\pi}{2}(0.90)^3(8) = 9.16 \text{ kip} \cdot \text{in}$$

The allowable torque is the smaller value.

$$T = 9.16 \text{ kip} \cdot \text{in} \quad \blacktriangleleft$$

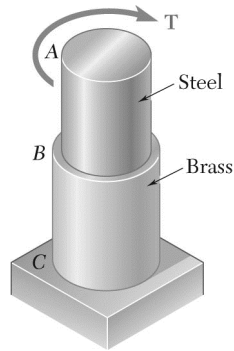

PROBLEM 3.16

The allowable shearing stress is 15 ksi in the steel rod AB and 8 ksi in the brass rod BC . Knowing that a torque of magnitude $T = 10 \text{ kip} \cdot \text{in.}$ is applied at A , determine the required diameter of (a) rod AB , (b) rod BC .

SOLUTION

$$\tau_{\max} = \frac{Tc}{J}, \quad J = \frac{\pi}{2} c^4, \quad c^3 = \frac{2T}{\pi \tau_{\max}}$$

(a) Rod AB :

$$T = 10 \text{ kip} \cdot \text{in.} \quad \tau_{\max} = 15 \text{ ksi}$$

$$c^3 = \frac{(2)(10)}{\pi(15)} = 0.4244 \text{ in}^3$$

$$c = 0.7515 \text{ in.}$$

$$d = 2c = 1.503 \text{ in.} \blacktriangleleft$$

(b) Rod BC :

$$T = 10 \text{ kip} \cdot \text{in.} \quad \tau_{\max} = 8 \text{ ksi}$$

$$c^3 = \frac{(2)(10)}{\pi(8)} = 0.79577 \text{ in}^3$$

$$c = 0.9267 \text{ in.}$$

$$d = 2c = 1.853 \text{ in.} \blacktriangleleft$$

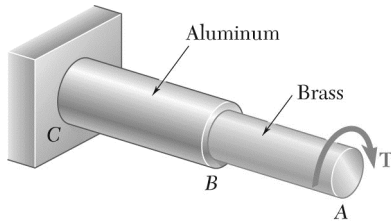

PROBLEM 3.17

The allowable stress is 50 MPa in the brass rod AB and 25 MPa in the aluminum rod BC . Knowing that a torque of magnitude $T = 1250 \text{ N} \cdot \text{m}$ is applied at A , determine the required diameter of (a) rod AB , (b) rod BC .

SOLUTION

$$\tau_{\max} = \frac{Tc}{J} \quad J = \frac{\pi}{2}c^4 \quad c^3 = \frac{2T}{\pi\tau_{\max}}$$

(a) Rod AB :

$$c^3 = \frac{(2)(1250)}{\pi(50 \times 10^6)} = 15.915 \times 10^{-6} \text{ m}^3$$

$$c = 25.15 \times 10^{-3} \text{ m} = 25.15 \text{ mm}$$

$$d_{AB} = 2c = 50.3 \text{ mm} \blacktriangleleft$$

(b) Rod BC :

$$c^3 = \frac{(2)(1250)}{\pi(25 \times 10^6)} = 31.831 \times 10^{-6} \text{ m}^3$$

$$c = 31.69 \times 10^{-3} \text{ m} = 31.69 \text{ mm}$$

$$d_{BC} = 2c = 63.4 \text{ mm} \blacktriangleleft$$

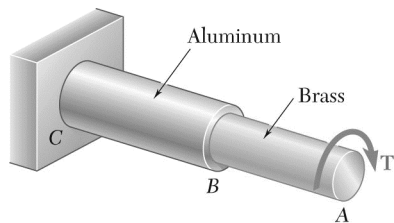

PROBLEM 3.18

The *solid* rod *BC* has a diameter of 30 mm and is made of an aluminum for which the allowable shearing stress is 25 MPa. Rod *AB* is *hollow* and has an outer diameter of 25 mm; it is made of a brass for which the allowable shearing stress is 50 MPa. Determine (a) the largest inner diameter of rod *AB* for which the factor of safety is the same for each rod, (b) the largest torque that can be applied at *A*.

SOLUTION

Solid rod BC:

$$\tau = \frac{Tc}{J} \quad J = \frac{\pi}{2}c^4$$

$$\tau_{\text{all}} = 25 \times 10^6 \text{ Pa}$$

$$c = \frac{1}{2}d = 0.015 \text{ m}$$

$$T_{\text{all}} = \frac{\pi}{2}c^3\tau_{\text{all}} = \frac{\pi}{2}(0.015)^3(25 \times 10^6) = 132.536 \text{ N} \cdot \text{m}$$

Hollow rod AB:

$$\tau_{\text{all}} = 50 \times 10^6 \text{ Pa}$$

$$T_{\text{all}} = 132.536 \text{ N} \cdot \text{m}$$

$$c_2 = \frac{1}{2}d_2 = \frac{1}{2}(0.025) = 0.0125 \text{ m}$$

$$c_1 = ?$$

$$T_{\text{all}} = \frac{J\tau_{\text{all}}}{c_2} = \frac{\pi}{2}(c_2^4 - c_1^4)\frac{\tau_{\text{all}}}{c_2}$$

$$c_1^4 = c_2^4 - \frac{2T_{\text{all}}c_2}{\pi\tau_{\text{all}}}$$

$$= 0.0125^4 - \frac{(2)(132.536)(0.0125)}{\pi(50 \times 10^6)} = 3.3203 \times 10^{-9} \text{ m}^4$$

(a) $c_1 = 7.59 \times 10^{-3} \text{ m} = 7.59 \text{ mm}$

$d_1 = 2c_1 = 15.18 \text{ mm} \blacktriangleleft$

(b) Allowable torque.

$T_{\text{all}} = 132.5 \text{ N} \cdot \text{m} \blacktriangleleft$

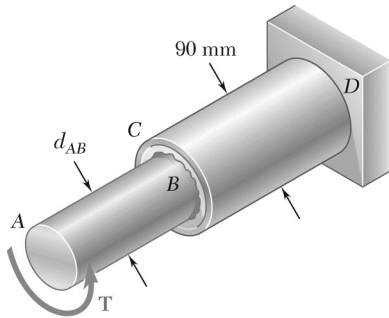

PROBLEM 3.19

The solid rod AB has a diameter $d_{AB} = 60$ mm. The pipe CD has an outer diameter of 90 mm and a wall thickness of 6 mm. Knowing that both the rod and the pipe are made of a steel for which the allowable shearing stress is 75 Mpa, determine the largest torque \mathbf{T} that can be applied at A .

SOLUTION

$$\tau_{\text{all}} = 75 \times 10^6 \text{ Pa} \quad T_{\text{all}} = \frac{J\tau_{\text{all}}}{c}$$

Rod AB :

$$c = \frac{1}{2}d = 0.030 \text{ m} \quad J = \frac{\pi}{2}c^4$$

$$\begin{aligned} T_{\text{all}} &= \frac{\pi}{2}c^3\tau_{\text{all}} = \frac{\pi}{2}(0.030)^3(75 \times 10^6) \\ &= 3.181 \times 10^3 \text{ N} \cdot \text{m} \end{aligned}$$

Pipe CD :

$$c_2 = \frac{1}{2}d_2 = 0.045 \text{ m} \quad c_1 = c_2 - t = 0.045 - 0.006 = 0.039 \text{ m}$$

$$J = \frac{\pi}{2}(c_2^4 - c_1^4) = \frac{\pi}{2}(0.045^4 - 0.039^4) = 2.8073 \times 10^{-6} \text{ m}^4$$

$$T_{\text{all}} = \frac{(2.8073 \times 10^{-6})(75 \times 10^6)}{0.045} = 4.679 \times 10^3 \text{ N} \cdot \text{m}$$

Allowable torque is the smaller value.

$$T_{\text{all}} = 3.18 \times 10^3 \text{ N} \cdot \text{m}$$

$$3.18 \text{ kN} \cdot \text{m} \quad \blacktriangleleft$$

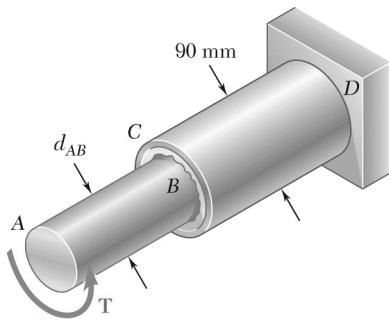

PROBLEM 3.20

The solid rod AB has a diameter $d_{AB} = 60$ mm and is made of a steel for which the allowable shearing stress is 85 MPa. The pipe CD , which has an outer diameter of 90 mm and a wall thickness of 6 mm, is made of an aluminum for which the allowable shearing stress is 54 MPa. Determine the largest torque T that can be applied at A .

SOLUTION

Rod AB : $\tau_{\text{all}} = 85 \times 10^6 \text{ Pa}$ $c = \frac{1}{2}d = 0.030 \text{ m}$

$$T_{\text{all}} = \frac{J\tau_{\text{all}}}{c} = \frac{\pi}{2}c^3\tau_{\text{all}}$$

$$= \frac{\pi}{2}(0.030)^3(85 \times 10^6) = 3.605 \times 10^3 \text{ N} \cdot \text{m}$$

Pipe CD : $\tau_{\text{all}} = 54 \times 10^6 \text{ Pa}$ $c_2 = \frac{1}{2}d_2 = 0.045 \text{ m}$

$$c_1 = c_2 - t = 0.045 - 0.006 = 0.039 \text{ m}$$

$$J = \frac{\pi}{2}(c_2^4 - c_1^4) = \frac{\pi}{2}(0.045^4 - 0.039^4) = 2.8073 \times 10^{-6} \text{ m}^4$$

$$T_{\text{all}} = \frac{J\tau_{\text{all}}}{c_2} = \frac{(2.8073 \times 10^{-6})(54 \times 10^6)}{0.045} = 3.369 \times 10^3 \text{ N} \cdot \text{m}$$

Allowable torque is the smaller value.

$$T_{\text{all}} = 3.369 \times 10^3 \text{ N} \cdot \text{m}$$

$$3.37 \text{ kN} \cdot \text{m} \blacktriangleleft$$

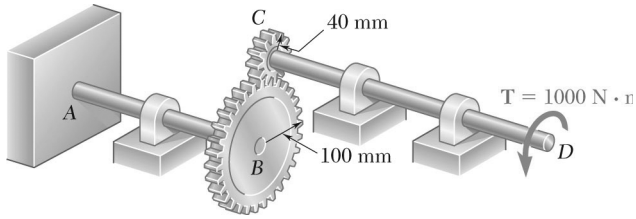

PROBLEM 3.21

A torque of magnitude $T = 1000 \text{ N} \cdot \text{m}$ is applied at D as shown. Knowing that the diameter of shaft AB is 56 mm and that the diameter of shaft CD is 42 mm, determine the maximum shearing stress in (a) shaft AB , (b) shaft CD .

SOLUTION

$$T_{CD} = 1000 \text{ N} \cdot \text{m}$$

$$T_{AB} = \frac{r_B}{r_C} T_{CD} = \frac{100}{40} (1000) = 2500 \text{ N} \cdot \text{m}$$

(a) Shaft AB : $c = \frac{1}{2}d = 0.028 \text{ m}$

$$\tau = \frac{Tc}{J} = \frac{2T}{\pi c^3} = \frac{(2)(2500)}{\pi (0.028)^3} = 72.50 \times 10^6 \quad 72.5 \text{ MPa} \blacktriangleleft$$

(b) Shaft CD : $c = \frac{1}{2}d = 0.020 \text{ m}$

$$\tau = \frac{Tc}{J} = \frac{2T}{\pi c^3} = \frac{(2)(1000)}{\pi (0.020)^3} = 68.7 \times 10^6 \quad 68.7 \text{ MPa} \blacktriangleleft$$

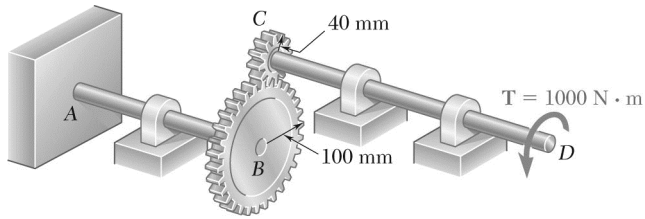

PROBLEM 3.22

A torque of magnitude $T = 1000 \text{ N} \cdot \text{m}$ is applied at D as shown. Knowing that the allowable shearing stress is 60 MPa in each shaft, determine the required diameter of (a) shaft AB , (b) shaft CD .

SOLUTION

$$T_{CD} = 1000 \text{ N} \cdot \text{m}$$

$$T_{AB} = \frac{r_B}{r_C} T_{CD} = \frac{100}{40} (1000) = 2500 \text{ N} \cdot \text{m}$$

(a) Shaft AB :

$$\tau_{\text{all}} = 60 \times 10^6 \text{ Pa}$$

$$\tau = \frac{Tc}{J} = \frac{2T}{\pi c^3} \quad c^3 = \frac{2T}{\pi \tau} = \frac{(2)(2500)}{\pi (60 \times 10^6)} = 26.526 \times 10^{-6} \text{ m}^3$$

$$c = 29.82 \times 10^{-3} = 29.82 \text{ mm} \qquad d = 2c = 59.6 \text{ mm} \blacktriangleleft$$

(b) Shaft CD :

$$\tau_{\text{all}} = 60 \times 10^6 \text{ Pa}$$

$$\tau = \frac{Tc}{J} = \frac{2T}{\pi c^3} \quad c^3 = \frac{2T}{\pi \tau} = \frac{(2)(1000)}{\pi (60 \times 10^6)} = 10.610 \times 10^{-6} \text{ m}^3$$

$$c = 21.97 \times 10^{-3} \text{ m} = 21.97 \text{ mm} \qquad d = 2c = 43.9 \text{ mm} \blacktriangleleft$$

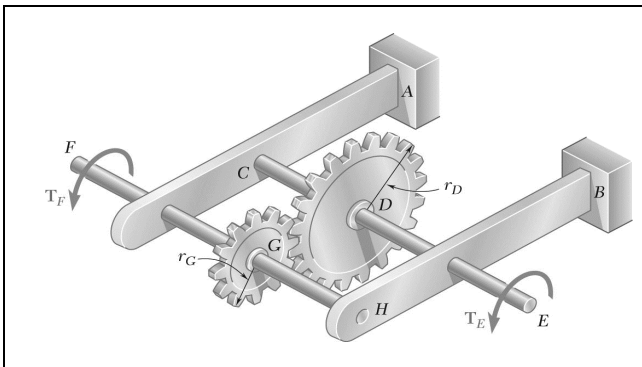

PROBLEM 3.23

Under normal operating conditions, a motor exerts a torque of magnitude $T_F = 1200 \text{ lb} \cdot \text{in.}$ at F . Knowing that $r_D = 8 \text{ in.}$, $r_G = 3 \text{ in.}$, and the allowable shearing stress is $10.5 \text{ ksi} \cdot \text{in}$ in each shaft, determine the required diameter of (a) shaft CDE , (b) shaft FGH .

SOLUTION

$$T_F = 1200 \text{ lb} \cdot \text{in}$$

$$T_E = \frac{r_D}{r_G} T_F = \frac{8}{3} (1200) = 3200 \text{ lb} \cdot \text{in}$$

$$\tau_{\text{all}} = 10.5 \text{ ksi} = 10500 \text{ psi}$$

$$\tau = \frac{Tc}{J} = \frac{2T}{\pi c^3} \quad \text{or} \quad c^3 = \frac{2T}{\pi \tau}$$

(a) Shaft CDE:

$$c^3 = \frac{(2)(3200)}{\pi (10500)} = 0.194012 \text{ in}^3$$

$$c = 0.5789 \text{ in.} \quad d_{DE} = 2c \quad d_{DE} = 1.158 \text{ in.} \quad \blacktriangleleft$$

(b) Shaft FGH:

$$c^3 = \frac{(2)(1200)}{\pi (10500)} = 0.012757 \text{ in}^3$$

$$c = 0.4174 \text{ in.} \quad d_{FG} = 2c \quad d_{FG} = 0.835 \text{ in.} \quad \blacktriangleleft$$

PROBLEM 3.24

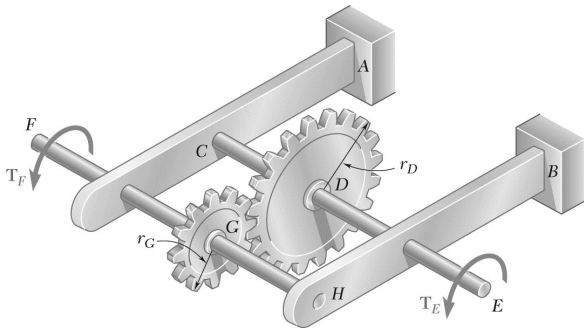

Under normal operating conditions, a motor exerts a torque of magnitude T_F at F . The shafts are made of a steel for which the allowable shearing stress is 12 ksi and have diameters $d_{CDE} = 0.900$ in. and $d_{FGH} = 0.800$ in. Knowing that $r_D = 6.5$ in. and $r_G = 4.5$ in., determine the largest allowable value of T_F .

SOLUTION

$$\tau_{\text{all}} = 12 \text{ ksi}$$

Shaft FG:

$$c = \frac{1}{2}d = 0.400 \text{ in.}$$

$$\begin{aligned} T_{F, \text{all}} &= \frac{J\tau_{\text{all}}}{c} = \frac{\pi}{2}c^3\tau_{\text{all}} \\ &= \frac{\pi}{2}(0.400)^3(12) = 1.206 \text{ kip} \cdot \text{in} \end{aligned}$$

Shaft DE:

$$c = \frac{1}{2}d = 0.450 \text{ in.}$$

$$\begin{aligned} T_{E, \text{all}} &= \frac{\pi}{2}c^3\tau_{\text{all}} \\ &= \frac{\pi}{2}(0.450)^3(12) = 1.7177 \text{ kip} \cdot \text{in} \end{aligned}$$

$$T_F = \frac{r_G}{r_D}T_E \quad T_{F, \text{all}} = \frac{4.5}{6.5}(1.7177) = 1.189 \text{ kip} \cdot \text{in}$$

Allowable value of T_F is the smaller.

$$T_F = 1.189 \text{ kip} \cdot \text{in} \quad \blacktriangleleft$$

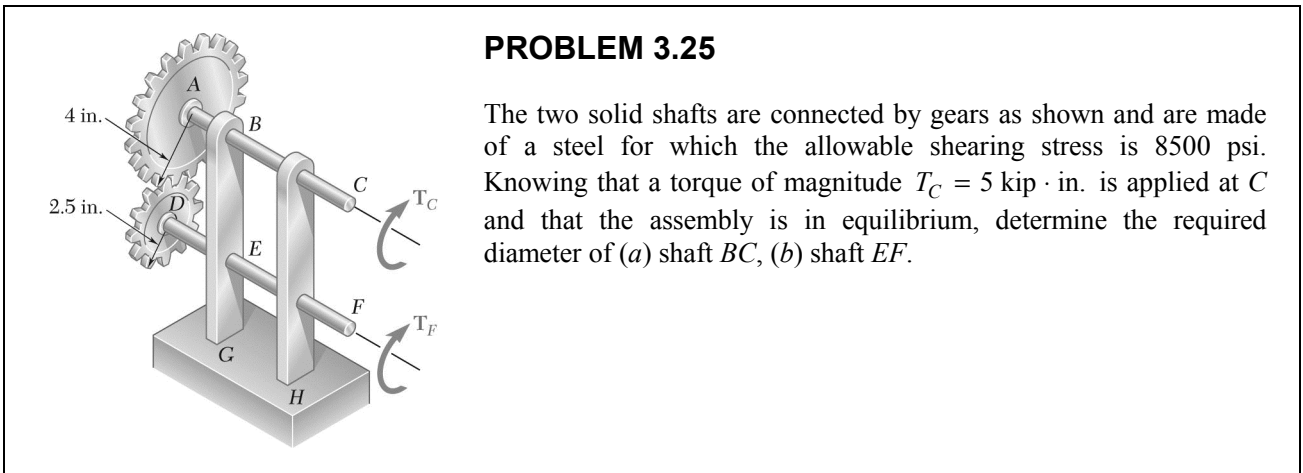

SOLUTION

$\tau_{\max} = 8500 \text{ psi} = 8.5 \text{ ksi}$

(a) Shaft BC :

$$T_C = 5 \text{ kip} \cdot \text{in}$$

$$\tau_{\max} = \frac{Tc}{J} = \frac{2T}{\pi c^3} \quad c = \sqrt[3]{\frac{2T}{\pi \tau_{\max}}}$$

$$c = \sqrt[3]{\frac{(2)(5)}{\pi(8.5)}} = 0.7208 \text{ in.}$$

$d_{BC} = 2c = 1.442 \text{ in.} \blacktriangleleft$

(b) Shaft EF :

$$T_F = \frac{r_D}{r_A} T_C = \frac{2.5}{4} (5) = 3.125 \text{ kip} \cdot \text{in}$$

$$c = \sqrt[3]{\frac{2T}{\pi \tau_{\max}}} = \sqrt[3]{\frac{(2)(3.125)}{\pi(8.5)}} = 0.6163 \text{ in.}$$

$d_{EF} = 2c = 1.233 \text{ in.} \blacktriangleleft$

PROBLEM 3.26

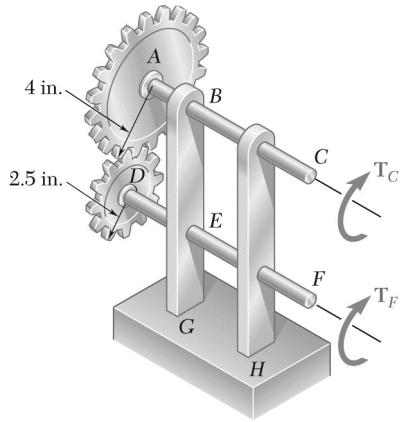

The two solid shafts are connected by gears as shown and are made of a steel for which the allowable shearing stress is 7000 psi. Knowing the diameters of the two shafts are, respectively, $d_{BC} = 1.6$ in. and $d_{EF} = 1.25$ in., determine the largest torque T_C that can be applied at C .

SOLUTION

$$\tau_{\max} = 7000 \text{ psi} = 7.0 \text{ ksi}$$

Shaft BC:

$$d_{BC} = 1.6 \text{ in.}$$

$$c = \frac{1}{2}d = 0.8 \text{ in.}$$

$$\begin{aligned} T_C &= \frac{J\tau_{\max}}{c} = \frac{\pi}{2}\tau_{\max}c^3 \\ &= \frac{\pi}{2}(7.0)(0.8)^3 = 5.63 \text{ kip} \cdot \text{in} \end{aligned}$$

Shaft EF:

$$d_{EF} = 1.25 \text{ in.}$$

$$c = \frac{1}{2}d = 0.625 \text{ in.}$$

$$\begin{aligned} T_F &= \frac{J\tau_{\max}}{c} = \frac{\pi}{2}\tau_{\max}c^3 \\ &= \frac{\pi}{2}(7.0)(0.625)^3 = 2.684 \text{ kip} \cdot \text{in} \end{aligned}$$

By statics,

$$T_C = \frac{r_A}{r_D} T_F = \frac{4}{2.5}(2.684) = 4.30 \text{ kip} \cdot \text{in}$$

Allowable value of T_C is the smaller.

$$T_C = 4.30 \text{ kip} \cdot \text{in} \quad \blacktriangleleft$$

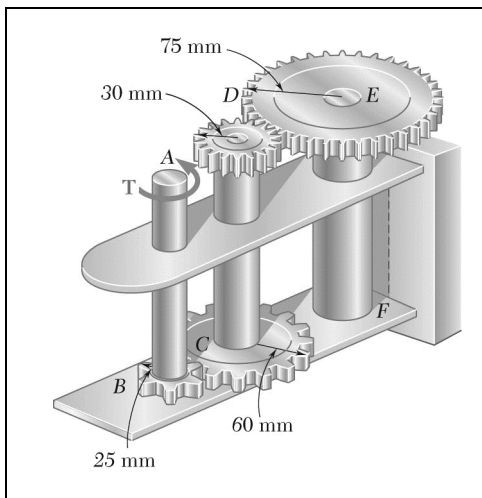

PROBLEM 3.27

A torque of magnitude $T = 100 \text{ N} \cdot \text{m}$ is applied to shaft AB of the gear train shown. Knowing that the diameters of the three solid shafts are, respectively, $d_{AB} = 21 \text{ mm}$, $d_{CD} = 30 \text{ mm}$, and $d_{EF} = 40 \text{ mm}$, determine the maximum shearing stress in (a) shaft AB , (b) shaft CD , (c) shaft EF .

SOLUTION

Statics:

Shaft AB : $T_{AB} = T_A = T_B = T$

Gears B and C : $r_B = 25 \text{ mm}, r_C = 60 \text{ mm}$

Force on gear circles.

$$F_{BC} = \frac{T_B}{r_B} = \frac{T_C}{r_C}$$

$$T_C = \frac{r_C}{r_B} T_B = \frac{60}{25} T = 2.4T$$

Shaft CD : $T_{CD} = T_C = T_D = 2.4T$

Gears D and E : $r_D = 30 \text{ mm}, r_E = 75 \text{ mm}$

Force on gear circles.

$$F_{DE} = \frac{T_D}{r_D} = \frac{T_E}{r_E}$$

$$T_E = \frac{r_E}{r_D} T_D = \frac{75}{30} (2.4T) = 6T$$

Shaft EF : $T_{EF} = T_E = T_F = 6T$

Maximum Shearing Stresses. $\tau_{\max} = \frac{Tc}{J} = \frac{2T}{\pi c^3}$

PROBLEM 3.27 (Continued)

(a) Shaft AB:

$$T = 100 \text{ N} \cdot \text{m}$$

$$c = \frac{1}{2}d = 10.5 \text{ mm} = 10.5 \times 10^{-3} \text{ m}$$

$$\tau_{\max} = \frac{(2)(100)}{\pi(10.5 \times 10^{-3})^3} = 55.0 \times 10^6 \text{ Pa} \qquad \tau_{\max} = 55.0 \text{ MPa} \blacktriangleleft$$

(b) Shaft CD:

$$T = (2.4)(100) = 240 \text{ N} \cdot \text{m}$$

$$c = \frac{1}{2}d = 15 \text{ mm} = 15 \times 10^{-3} \text{ m}$$

$$\tau_{\max} = \frac{(2)(240)}{\pi(15 \times 10^{-3})^3} = 45.3 \times 10^6 \text{ Pa} \qquad \tau_{\max} = 45.3 \text{ MPa} \blacktriangleleft$$

(c) Shaft EF:

$$T = (6)(100) = 600 \text{ N} \cdot \text{m}$$

$$c = \frac{1}{2}d = 20 \text{ mm} = 20 \times 10^{-3} \text{ m}$$

$$\tau_{\max} = \frac{(2)(600)}{\pi(20 \times 10^{-3})^3} = 47.7 \times 10^6 \text{ Pa} \qquad \tau_{\max} = 47.7 \text{ MPa} \blacktriangleleft$$

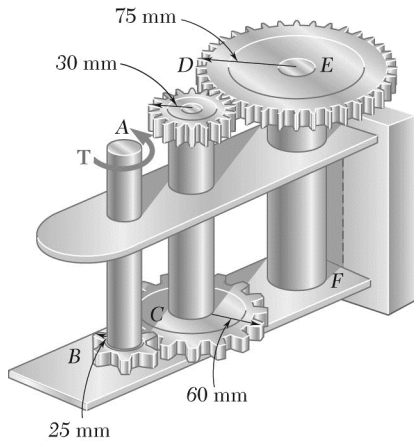

PROBLEM 3.28

A torque of magnitude $T = 120 \text{ N} \cdot \text{m}$ is applied to shaft AB of the gear train shown. Knowing that the allowable shearing stress is 75 MPa in each of the three solid shafts, determine the required diameter of (a) shaft AB , (b) shaft CD , (c) shaft EF .

SOLUTION

Statics:

Shaft AB : $T_{AB} = T_A = T_B = T$

Gears B and C : $r_B = 25 \text{ mm}, r_C = 60 \text{ mm}$

Force on gear circles.

$$F_{BC} = \frac{T_B}{r_B} = \frac{T_C}{r_C}$$

$$T_C = \frac{r_C}{r_B} T_B = \frac{60}{25} T = 2.4T$$

Shaft CD : $T_{CD} = T_C = T_D = 2.4T$

Gears D and E : $r_D = 30 \text{ mm}, r_E = 75 \text{ mm}$

Force on gear circles.

$$F_{DE} = \frac{T_D}{r_D} = \frac{T_E}{r_E}$$

$$T_E = \frac{r_E}{r_D} T_D = \frac{75}{30} (2.4T) = 6T$$

Shaft EF : $T_{EF} = T_E = T_F = 6T$

Required Diameters.

$$\tau_{\max} = \frac{Tc}{J} = \frac{2T}{\pi c^3}$$

$$c = \sqrt[3]{\frac{2T}{\pi\tau}}$$

$$d = 2c = 2\sqrt[3]{\frac{2T}{\pi\tau_{\max}}}$$

$$\tau_{\max} = 75 \times 10^6 \text{ Pa}$$

PROBLEM 3.28 (Continued)

(a) Shaft AB:

$$T_{AB} = T = 120 \text{ N} \cdot \text{m}$$

$$d_{AB} = 2\sqrt[3]{\frac{2(120)}{\pi(75 \times 10^6)}} = 20.1 \times 10^{-3} \text{ m}$$

$$d_{AB} = 20.1 \text{ mm} \blacktriangleleft$$

(b) Shaft CD:

$$T_{CD} = (2.4)(120) = 288 \text{ N} \cdot \text{m}$$

$$d_{CD} = 2\sqrt[3]{\frac{(2)(288)}{\pi(75 \times 10^6)}} = 26.9 \times 10^{-3} \text{ m}$$

$$d_{CD} = 26.9 \text{ mm} \blacktriangleleft$$

(c) Shaft EF:

$$T_{EF} = (6)(120) = 720 \text{ N} \cdot \text{m}$$

$$d_{EF} = 2\sqrt[3]{\frac{(2)(720)}{\pi(75 \times 10^3)}} = 36.6 \times 10^{-3} \text{ m}$$

$$d_{EF} = 36.6 \text{ mm} \blacktriangleleft$$

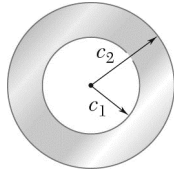

PROBLEM 3.29

(a) For a given allowable shearing stress, determine the ratio T/w of the maximum allowable torque T and the weight per unit length w for the hollow shaft shown. (b) Denoting by $(T/w)_0$ the value of this ratio for a solid shaft of the same radius c_2 , express the ratio T/w for the hollow shaft in terms of $(T/w)_0$ and c_1/c_2 .

SOLUTION

w = weight per unit length,

ρg = specific weight,

W = total weight,

L = length

$$w = \frac{W}{L} = \frac{\rho g L A}{L} = \rho g A = \rho g \pi (c_2^2 - c_1^2)$$

$$T_{\text{all}} = \frac{J \tau_{\text{all}}}{c_2} = \frac{\pi c_2^4 - c_1^4}{2 c_2} \tau_{\text{all}} = \frac{\pi (c_2^2 + c_1^2)(c_2^2 - c_1^2)}{2 c_2} \tau_{\text{all}}$$

$$(a) \quad \frac{T}{W} = (c_1^2 + c_2^2) \tau_{\text{all}} \qquad \frac{T}{w} = \frac{(c_1^2 + c_2^2) \tau_{\text{all}}}{2 \rho g c_2} \quad (\text{hollow shaft}) \blacktriangleleft$$

$c_1 = 0$ for solid shaft:

$$\left(\frac{T}{w}\right)_0 = \frac{c_2 \tau_{\text{all}}}{2 \rho g} \quad (\text{solid shaft})$$

$$(b) \quad \frac{(T/w)_h}{(T/w)_0} = 1 + \frac{c_1^2}{c_2^2} \qquad \left(\frac{T}{w}\right) = \left(\frac{T}{w}\right)_0 \left(1 + \frac{c_1^2}{c_2^2}\right) \blacktriangleleft$$

PROBLEM 3.30

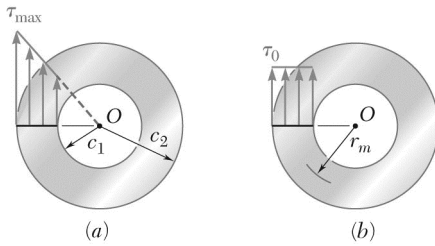

While the exact distribution of the shearing stresses in a hollow-cylindrical shaft is as shown in Fig. *a*, an approximate value can be obtained for τ_{\max} by assuming that the stresses are uniformly distributed over the area A of the cross section, as shown in Fig. *b*, and then further assuming that all of the elementary shearing forces act at a distance from O equal to the mean radius $\frac{1}{2}(c_1 + c_2)$ of the cross section. This approximate value $\tau_0 = T/Ar_m$, where T is the applied torque. Determine the ratio τ_{\max}/τ_0 of the true value of the maximum shearing stress and its approximate value τ_0 for values of c_1/c_2 , respectively equal to 1.00, 0.95, 0.75, 0.50, and 0.

SOLUTION

For a hollow shaft:

$$\tau_{\max} = \frac{Tc_2}{J} = \frac{2Tc_2}{\pi(c_2^4 - c_1^4)} = \frac{2Tc_2}{\pi(c_2^2 - c_1^2)(c_2^2 + c_1^2)} = \frac{2Tc_2}{A(c_2^2 + c_1^2)}$$

By definition,

$$\tau_0 = \frac{T}{Ar_m} = \frac{2T}{A(c_2 + c_1)}$$

Dividing,

$$\frac{\tau_{\max}}{\tau_0} = \frac{c_2(c_2 + c_1)}{c_2^2 + c_1^2} = \frac{1 + (c_1/c_2)}{1 + (c_1/c_2)^2}$$

c_1/c_2	1.0	0.95	0.75	0.5	0.0
τ_{\max}/τ_0	1.0	1.025	1.120	1.200	1.0

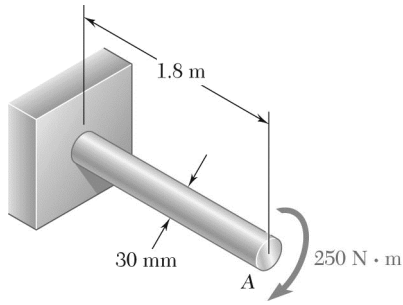

PROBLEM 3.31

(a) For the solid steel shaft shown ($G = 77 \text{ GPa}$), determine the angle of twist at A . (b) Solve part a , assuming that the steel shaft is hollow with a 30-mm-outer diameter and a 20-mm-inner diameter.

SOLUTION

$$(a) \quad c = \frac{1}{2}d = 0.015 \text{ m}, \quad J = \frac{\pi}{2}c^4 = \frac{\pi}{2}(0.015)^4$$

$$J = 79.522 \times 10^{-9} \text{ m}^4, \quad L = 1.8 \text{ m}, \quad G = 77 \times 10^9 \text{ Pa}$$

$$T = 250 \text{ N} \cdot \text{m} \quad \varphi = \frac{TL}{GJ}$$

$$\varphi = \frac{(250)(1.8)}{(77 \times 10^9)(79.522 \times 10^{-9})} = 73.49 \times 10^{-3} \text{ rad}$$

$$\varphi = \frac{(73.49 \times 10^{-3})180}{\pi}$$

$$\varphi = 4.21^\circ \quad \blacktriangleleft$$

$$(b) \quad c_2 = 0.015 \text{ m}, \quad c_1 = \frac{1}{2}d_1 = 0.010 \text{ m}, \quad J = \frac{\pi}{2}(c_2^4 - c_1^4)$$

$$J = \frac{\pi}{2}(0.015^4 - 0.010^4) = 63.814 \times 10^{-9} \text{ m}^4 \quad \varphi = \frac{TL}{GJ}$$

$$\varphi = \frac{(250)(1.8)}{(77 \times 10^9)(63.814 \times 10^{-9})} = 91.58 \times 10^{-3} \text{ rad} = \frac{180}{\pi}(91.58 \times 10^{-3})$$

$$\varphi = 5.25^\circ \quad \blacktriangleleft$$

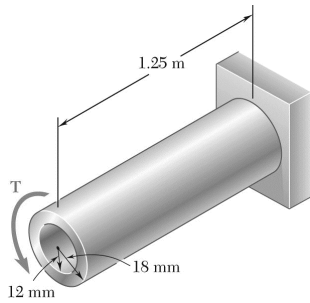

PROBLEM 3.32

For the aluminum shaft shown ($G = 27 \text{ GPa}$), determine (a) the torque T that causes an angle of twist of 4° , (b) the angle of twist caused by the same torque T in a solid cylindrical shaft of the same length and cross-sectional area.

SOLUTION

(a)

$$\varphi = \frac{TL}{GJ} \quad T = \frac{GJ\varphi}{L}$$

$$\varphi = 4^\circ = 69.813 \times 10^{-3} \text{ rad}, \quad L = 1.25 \text{ m}$$

$$G = 27 \text{ GPa} = 27 \times 10^9 \text{ Pa}$$

$$J = \frac{\pi}{2}(c_2^4 - c_1^4) = \frac{\pi}{2}(0.018^4 - 0.012^4) = 132.324 \times 10^{-9} \text{ m}^4$$

$$T = \frac{(27 \times 10^9)(132.324 \times 10^{-9})(69.813 \times 10^{-3})}{1.25}$$

$$= 199.539 \text{ N} \cdot \text{m} \qquad T = 199.5 \text{ N} \cdot \text{m} \blacktriangleleft$$

(b) Matching areas:

$$A = \pi c^2 = \pi(c_2^2 - c_1^2)$$

$$c = \sqrt{c_2^2 - c_1^2} = \sqrt{0.018^2 - 0.012^2} = 0.013416 \text{ m}$$

$$J = \frac{\pi}{2}c^4 = \frac{\pi}{2}(0.013416)^4 = 50.894 \times 10^{-9} \text{ m}^4$$

$$\varphi = \frac{TL}{GJ} = \frac{(199.539)(1.25)}{(27 \times 10^9)(50.894 \times 10^{-9})} = 181.514 \times 10^{-3} \text{ rad} \qquad \varphi = 10.40^\circ \blacktriangleleft$$

PROBLEM 3.33

Determine the largest allowable diameter of a 10-ft-long steel rod ($G = 11.2 \times 10^6$ psi) if the rod is to be twisted through 30° without exceeding a shearing stress of 12 ksi.

SOLUTION

$$L = 10 \text{ ft} = 120 \text{ in.} \quad \phi = 30^\circ = \frac{30\pi}{180} = 0.52360 \text{ rad}$$

$$\tau = 12 \text{ ksi} = 12 \times 10^3 \text{ psi}$$

$$\phi = \frac{TL}{GJ}, \quad T = \frac{GJ\phi}{L}, \quad \tau = \frac{Tc}{J} = \frac{GJ\phi c}{JL} = \frac{G\phi c}{L}, \quad c = \frac{\tau L}{G\phi}$$

$$c = \frac{(12 \times 10^3)(120)}{(11.2 \times 10^6)(0.52360)} = 0.24555 \text{ in.}$$

$$d = 2c = 0.491 \text{ in.} \quad \blacktriangleleft$$

PROBLEM 3.34

While an oil well is being drilled at a depth of 6000 ft, it is observed that the top of the 8-in.-diameter steel drill pipe rotates through two complete revolutions before the drilling bit starts to rotate. Using $G = 11.2 \times 10^6$ psi, determine the maximum shearing stress in the pipe caused by torsion.

SOLUTION

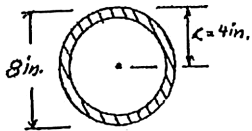

For outside diameter of 8 in., $c = 4$ in.

For two revolutions, $\phi = 2(2\pi) = 4\pi$ radians.

$$G = 11.2 \times 10^6 \text{ psi}$$

$$L = 6000 \text{ ft} = 72000 \text{ in.}$$

From text book,

$$\phi = \frac{TL}{GJ} \quad (1)$$

$$\tau_m = \frac{Tc}{J} \quad (2)$$

Divide (2) by (1).

$$\frac{\tau_m}{\phi} = \frac{Gc}{L}$$

$$\tau_m = \frac{Gc\phi}{L} = \frac{(11 \times 10^6)(4)(4\pi)}{72000} = 7679 \text{ psi}$$

$$\tau_m = 7.68 \text{ ksi} \blacktriangleleft$$

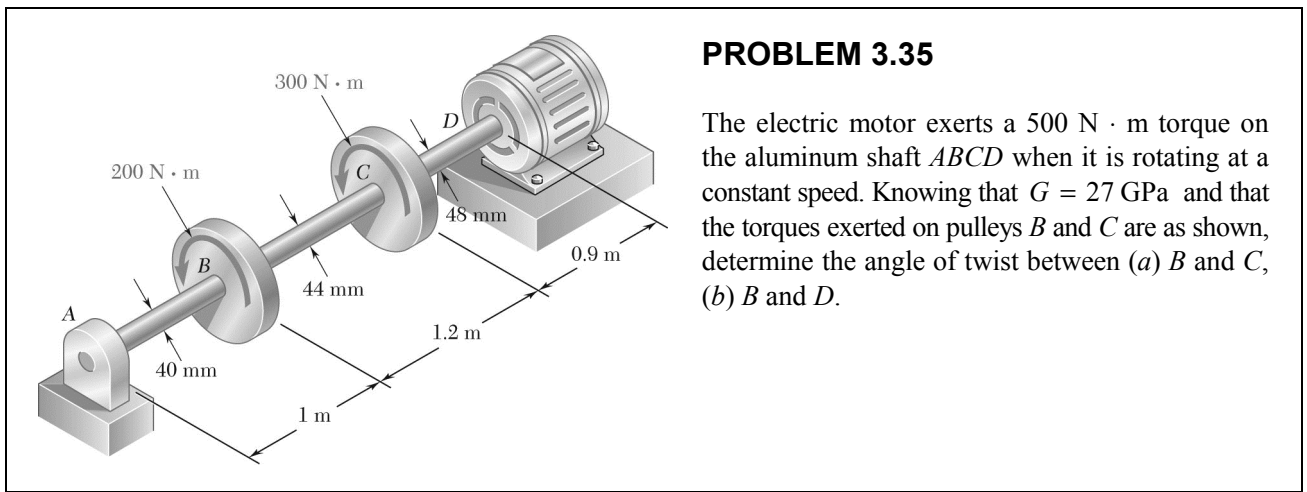

PROBLEM 3.35

The electric motor exerts a $500 \text{ N} \cdot \text{m}$ torque on the aluminum shaft $ABCD$ when it is rotating at a constant speed. Knowing that $G = 27 \text{ GPa}$ and that the torques exerted on pulleys B and C are as shown, determine the angle of twist between (a) B and C , (b) B and D .

SOLUTION

(a) Angle of twist between B and C .

$$T_{BC} = 200 \text{ N} \cdot \text{m}, \quad L_{BC} = 1.2 \text{ m}$$

$$c = \frac{1}{2}d = 0.022 \text{ m}, \quad G = 27 \times 10^9 \text{ Pa}$$

$$J_{BC} = \frac{\pi}{2}c^4 = 367.97 \times 10^{-9} \text{ m}^4$$

$$\varphi_{B/C} = \frac{TL}{GJ} = \frac{(200)(1.2)}{(27 \times 10^9)(367.97 \times 10^{-9})} = 24.157 \times 10^{-3} \text{ rad} \quad \varphi_{B/C} = 1.384^\circ \blacktriangleleft$$

(b) Angle of twist between B and D .

$$T_{CD} = 500 \text{ N} \cdot \text{m}, \quad L_{CD} = 0.9 \text{ m}, \quad c = \frac{1}{2}d = 0.024 \text{ m}, \quad G = 27 \times 10^9 \text{ Pa}$$

$$J_{CD} = \frac{\pi}{2}c^4 = \frac{\pi}{2}(0.024)^4 = 521.153 \times 10^{-9} \text{ m}^4$$

$$\varphi_{C/D} = \frac{(500)(0.9)}{(27 \times 10^9)(521.153 \times 10^{-9})} = 31.980 \times 10^{-3} \text{ rad}$$

$$\varphi_{B/D} = \varphi_{B/C} + \varphi_{C/D} = 24.157 \times 10^{-3} + 31.980 \times 10^{-3} = 56.137 \times 10^{-3} \text{ rad} \quad \varphi_{B/D} = 3.22^\circ \blacktriangleleft$$

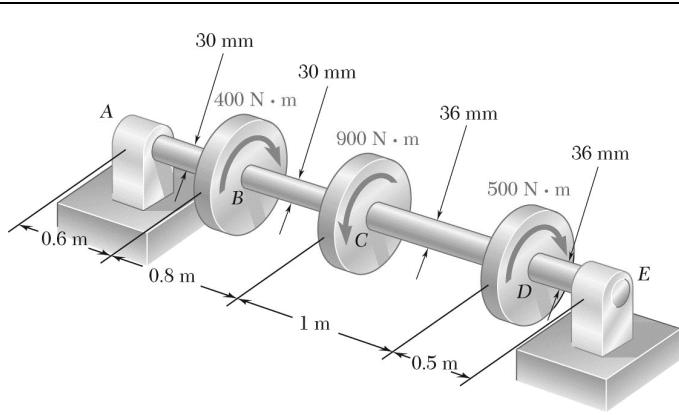

PROBLEM 3.36

The torques shown are exerted on pulleys *B*, *C*, and *D*. Knowing that the entire shaft is made of steel ($G = 27 \text{ GPa}$), determine the angle of twist between (a) *C* and *B*, (b) *D* and *B*.

SOLUTION

(a) Shaft BC:

$$c = \frac{1}{2}d = 0.015 \text{ m}$$

$$J_{BC} = \frac{\pi}{4}c^4 = 79.522 \times 10^{-9} \text{ m}^4$$

$$L_{BC} = 0.8 \text{ m}, \quad G = 27 \times 10^9 \text{ Pa}$$

$$\varphi_{BC} = \frac{TL}{GJ} = \frac{(400)(0.8)}{(27 \times 10^9)(79.522 \times 10^{-9})} = 0.149904 \text{ rad} \quad \varphi_{BC} = 8.54^\circ \blacktriangleleft$$

(b) Shaft CD:

$$c = \frac{1}{2}d = 0.018 \text{ m} \quad J_{CD} = \frac{\pi}{4}c^4 = 164.896 \times 10^{-9} \text{ m}^4$$

$$L_{CD} = 1.0 \text{ m} \quad T_{CD} = 400 - 900 = -500 \text{ N} \cdot \text{m}$$

$$\varphi_{CD} = \frac{TL}{GJ} = \frac{(-500)(1.0)}{(27 \times 10^9)(164.896 \times 10^{-9})} = -0.11230 \text{ rad}$$

$$\varphi_{BD} = \varphi_{BC} + \varphi_{CD} = 0.14904 - 0.11230 = 0.03674 \text{ rad}$$

$$\varphi_{BD} = 2.11^\circ \blacktriangleleft$$

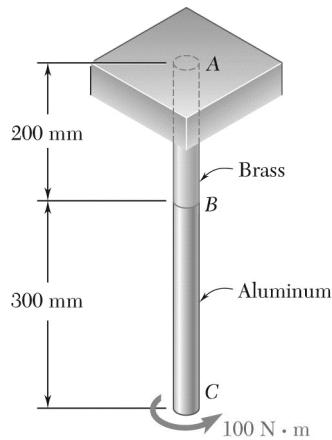

PROBLEM 3.37

The aluminum rod BC ($G = 26$ GPa) is bonded to the brass rod AB ($G = 39$ GPa). Knowing that each rod is solid and has a diameter of 12 mm, determine the angle of twist (a) at B , (b) at C .

SOLUTION

Both portions:

$$c = \frac{1}{2}d = 6 \text{ mm} = 6 \times 10^{-3} \text{ m}$$

$$J = \frac{\pi}{2}c^4 = \frac{\pi}{2}(6 \times 10^{-3})^4 = 2.03575 \times 10^{-9} \text{ m}^4$$

$$T = 100 \text{ N} \cdot \text{m}$$

Rod AB: $G_{AB} = 39 \times 10^9 \text{ Pa}$, $L_{AB} = 0.200 \text{ m}$

$$(a) \quad \varphi_B = \varphi_{AB} = \frac{TL_{AB}}{G_{AB}J} = \frac{(100)(0.200)}{(39 \times 10^9)(2.03575 \times 10^{-9})} = 0.25191 \text{ rad} \quad \varphi_B = 14.43^\circ \blacktriangleleft$$

Rod BC: $G_{BC} = 26 \times 10^9 \text{ Pa}$, $L_{BC} = 0.300 \text{ m}$

$$\varphi_{BC} = \frac{TL_{BC}}{G_{BC}J} = \frac{(100)(0.300)}{(26 \times 10^9)(2.03575 \times 10^{-9})} = 0.56679 \text{ rad}$$

$$(b) \quad \varphi_C = \varphi_B + \varphi_{BC} = 0.25191 + 0.56679 = 0.81870 \text{ rad} \quad \varphi_C = 46.9^\circ \blacktriangleleft$$

PROBLEM 3.38

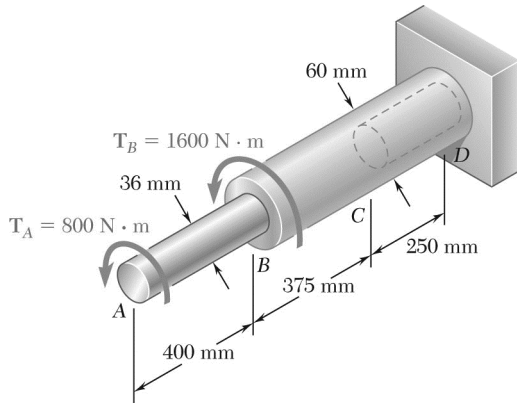

The aluminum rod AB ($G = 27\text{ GPa}$) is bonded to the brass rod BD ($G = 39\text{ GPa}$). Knowing that portion CD of the brass rod is hollow and has an inner diameter of 40 mm, determine the angle of twist at A .

SOLUTION

Rod AB :

$$G = 27 \times 10^9 \text{ Pa}, \quad L = 0.400 \text{ m}$$

$$T = 800 \text{ N} \cdot \text{m} \quad c = \frac{1}{2}d = 0.018 \text{ m}$$

$$J = \frac{\pi}{2}c^4 = \frac{\pi}{2}(0.018)^4 = 164.896 \times 10^{-9} \text{ m}^4$$

$$\varphi_{A/B} = \frac{TL}{GJ} = \frac{(800)(0.400)}{(27 \times 10^9)(164.896 \times 10^{-9})} = 71.875 \times 10^{-3} \text{ rad}$$

Part BC :

$$G = 39 \times 10^9 \text{ Pa} \quad L = 0.375 \text{ m}, \quad c = \frac{1}{2}d = 0.030 \text{ m}$$

$$T = 800 + 1600 = 2400 \text{ N} \cdot \text{m}, \quad J = \frac{\pi}{2}c^4 = \frac{\pi}{2}(0.030)^4 = 1.27234 \times 10^{-6} \text{ m}^4$$

$$\varphi_{B/C} = \frac{TL}{GJ} = \frac{(2400)(0.375)}{(39 \times 10^9)(1.27234 \times 10^{-6})} = 18.137 \times 10^{-3} \text{ rad}$$

Part CD :

$$c_1 = \frac{1}{2}d_1 = 0.020 \text{ m}$$

$$c_2 = \frac{1}{2}d_2 = 0.030 \text{ m}, \quad L = 0.250 \text{ m}$$

$$J = \frac{\pi}{2}(c_2^4 - c_1^4) = \frac{\pi}{2}(0.030^4 - 0.020^4) = 1.02102 \times 10^{-6} \text{ m}^4$$

$$\varphi_{C/D} = \frac{TL}{GJ} = \frac{(2400)(0.250)}{(39 \times 10^9)(1.02102 \times 10^{-6})} = 15.068 \times 10^{-3} \text{ rad}$$

Angle of twist at A .

$$\varphi_A = \varphi_{A/B} + \varphi_{B/C} + \varphi_{C/D}$$

$$= 105.080 \times 10^{-3} \text{ rad}$$

$$\varphi_A = 6.02^\circ \blacktriangleleft$$

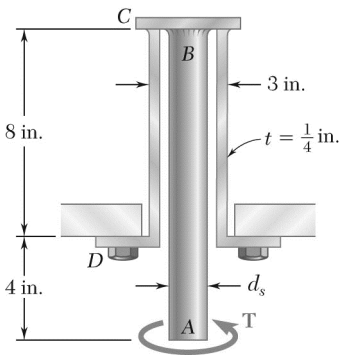

PROBLEM 3.39

The solid spindle AB has a diameter $d_s = 1.5$ in. and is made of a steel with $G = 11.2 \times 10^6$ psi and $\tau_{\text{all}} = 12$ ksi, while sleeve CD is made of a brass with $G = 5.6 \times 10^6$ psi and $\tau_{\text{all}} = 7$ ksi. Determine the angle through end A can be rotated.

SOLUTION

Stress analysis of solid spindle AB :

$$c = \frac{1}{2}d_s = 0.75 \text{ in.}$$

$$\tau = \frac{Tc}{J} \quad T = \frac{J\tau}{c} = \frac{\pi}{2}\tau c^3$$

$$T = \frac{\pi}{2}(12 \times 10^3)(0.75)^3 = 7.95 \times 10^3 \text{ lb} \cdot \text{in}$$

Stress analysis of sleeve CD :

$$c_2 = \frac{1}{2}d_o = \frac{1}{2}(3) = 1.5 \text{ in.}$$

$$c_1 = c_2 - t = 1.5 - 0.25 = 1.25 \text{ in.}$$

$$J = \frac{\pi}{2}(c_2^4 - c_1^4) = \frac{\pi}{2}(1.5^4 - 1.25^4) = 4.1172 \text{ in}^4$$

$$T = \frac{J\tau}{c_2} = \frac{(4.1172)(7 \times 10^3)}{1.5} = 19.21 \times 10^3 \text{ lb} \cdot \text{in}$$

The smaller torque governs.

$$T = 7.95 \times 10^3 \text{ lb} \cdot \text{in}$$

Deformation of spindle AB :

$$c = 0.75 \text{ in.}$$

$$J = \frac{\pi}{2}c^4 = 0.49701 \text{ in}^4, \quad L = 12 \text{ in.}, \quad G = 11.2 \times 10^6 \text{ psi}$$

$$\varphi_{AB} = \frac{TL}{GJ} = \frac{(7.95 \times 10^3)(12)}{(11.2 \times 10^6)(0.49701)} = 0.017138 \text{ radians}$$

Deformation of sleeve CD :

$$J = 4.1172 \text{ in}^4, \quad L = 8 \text{ in.}, \quad G = 5.6 \times 10^6 \text{ psi}$$

$$\varphi_{CD} = \frac{TL}{GJ} = \frac{(7.95 \times 10^3)(8)}{(5.6 \times 10^6)(4.1172)} = 0.002758 \text{ radians}$$

Total angle of twist:

$$\varphi_{AD} = \varphi_{AB} + \varphi_{CD} = 0.019896 \text{ radians}$$

$$\varphi_{AD} = 1.140^\circ \blacktriangleleft$$

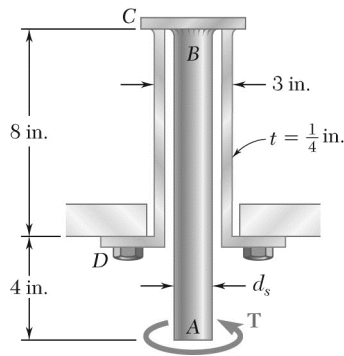

PROBLEM 3.40

The solid spindle AB has a diameter $d_s = 1.75$ in. and is made of a steel with $G = 11.2 \times 10^6$ psi and $\tau_{\text{all}} = 12$ ksi, while sleeve CD is made of a brass with $G = 5.6 \times 10^6$ psi and $\tau_{\text{all}} = 7$ ksi. Determine (a) the largest torque T that can be applied at A if the given allowable stresses are not to be exceeded and if the angle of twist of sleeve CD is not to exceed 0.375° , (b) the corresponding angle through which end A rotates.

SOLUTION

Spindle AB : $c = \frac{1}{2}(1.75 \text{ in.}) = 0.875 \text{ in.}$ $L = 12 \text{ in.}$ $\tau_{\text{all}} = 12 \text{ ksi}$, $G = 11.2 \times 10^6 \text{ psi}$

$$J = \frac{\pi}{2}c^4 = \frac{\pi}{2}(0.875)^4 = 0.92077 \text{ in}^4$$

Sleeve CD : $c_1 = 1.25 \text{ in.}$, $c_2 = 1.5 \text{ in.}$, $L = 8 \text{ in.}$, $\tau_{\text{all}} = 7 \text{ ksi}$

$$J = \frac{\pi}{2}(c_2^4 - c_1^4) = 4.1172 \text{ in}^4, \quad G = 5.6 \times 10^6 \text{ psi}$$

(a) Largest allowable torque T .

Criterion: Stress in spindle AB . $\tau = \frac{Tc}{J}$ $T = \frac{J\tau}{c}$

$$T = \frac{(0.92077)(12)}{0.875} = 12.63 \text{ kip} \cdot \text{in}$$

Criterion: Stress in sleeve CD . $T = \frac{J\tau}{c_2} = \frac{4.1172 \text{ in}^4}{1.5 \text{ in.}} (7 \text{ ksi})$ $T = 19.21 \text{ kip} \cdot \text{in}$

Criterion: Angle of twist of sleeve CD $\phi = 0.375^\circ = 6.545 \times 10^{-3} \text{ rad}$

$$\phi = \frac{TL}{JG} \quad T = \frac{JG}{L} \phi = \frac{(4.1172)(5.6 \times 10^6)}{8} (6.545 \times 10^{-3})$$

$$T = 18.86 \text{ kip} \cdot \text{in}$$

The largest allowable torque is

$$T = 12.63 \text{ kip} \cdot \text{in} \quad \blacktriangleleft$$

(b) Angle of rotation of end A .

$$\phi_A = \phi_{A/D} = \phi_{A/B} + \phi_{C/D} = \sum \frac{T_i L_i}{J_i G_i} = T \sum \frac{L_i}{J_i G_i}$$

$$= (12.63 \times 10^3) \left[\frac{12}{(0.92077)(11.2 \times 10^6)} + \frac{8}{(4.1172)(5.6 \times 10^6)} \right]$$

$$= 0.01908 \text{ radians}$$

$$\phi_A = 1.093^\circ \quad \blacktriangleleft$$

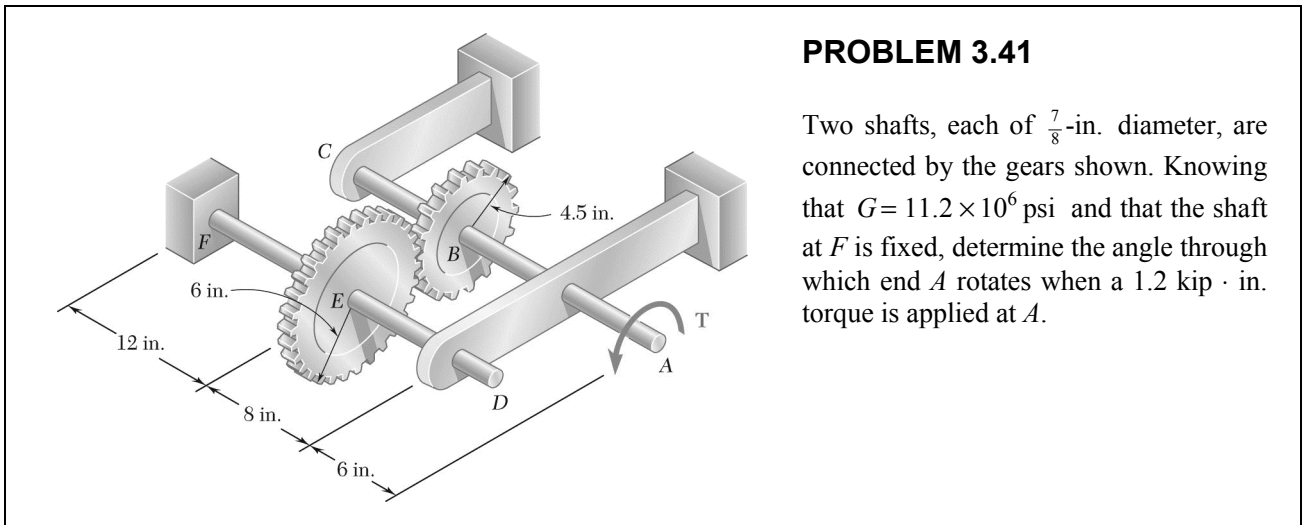

PROBLEM 3.41

Two shafts, each of $\frac{7}{8}$ -in. diameter, are connected by the gears shown. Knowing that $G = 11.2 \times 10^6$ psi and that the shaft at F is fixed, determine the angle through which end A rotates when a 1.2 kip · in. torque is applied at A .

SOLUTION

Calculation of torques.

Circumferential contact force between gears B and E .
$$F = \frac{T_{AB}}{r_B} = \frac{T_{EF}}{r_E} \quad T_{EF} = \frac{r_E}{r_B} T_{AB}$$

$$T_{AB} = 1.2 \text{ kip} \cdot \text{in} = 1200 \text{ lb} \cdot \text{in}$$

$$T_{EF} = \frac{6}{4.5}(1200) = 1600 \text{ lb} \cdot \text{in}$$

Twist in shaft FE .

$$L = 12 \text{ in.}, \quad c = \frac{1}{2}d = \frac{7}{16} \text{ in.}, \quad G = 11.2 \times 10^6 \text{ psi}$$

$$J = \frac{\pi}{2}c^4 = \frac{\pi}{2}\left(\frac{7}{16}\right)^4 = 57.548 \times 10^{-3} \text{ in}^4$$

$$\varphi_{E/F} = \frac{TL}{GJ} = \frac{(1600)(12)}{(11.2 \times 10^6)(57.548 \times 10^{-3})} = 29.789 \times 10^{-3} \text{ rad}$$

Rotation at E .

$$\varphi_E = \varphi_{E/F} = 29.789 \times 10^{-3} \text{ rad}$$

Tangential displacement at gear circle. $\delta = r_E \varphi_E = r_B \varphi_B$

Rotation at B .

$$\varphi_B = \frac{r_E}{r_B} \varphi_E = \frac{6}{4.5}(29.789 \times 10^{-3}) = 39.718 \times 10^{-3} \text{ rad}$$

Twist in shaft BA .

$$L = 8 + 6 = 14 \text{ in.} \quad J = 57.548 \times 10^{-3} \text{ in}^4$$

$$\varphi_{A/B} = \frac{TL}{GJ} = \frac{(1200)(14)}{(11.2 \times 10^6)(57.548 \times 10^{-3})} = 26.065 \times 10^{-3} \text{ rad}$$

Rotation at A .

$$\varphi_A = \varphi_B + \varphi_{A/B} = 65.783 \times 10^{-3} \text{ rad}$$

$$\varphi_A = 3.77^\circ \blacktriangleleft$$

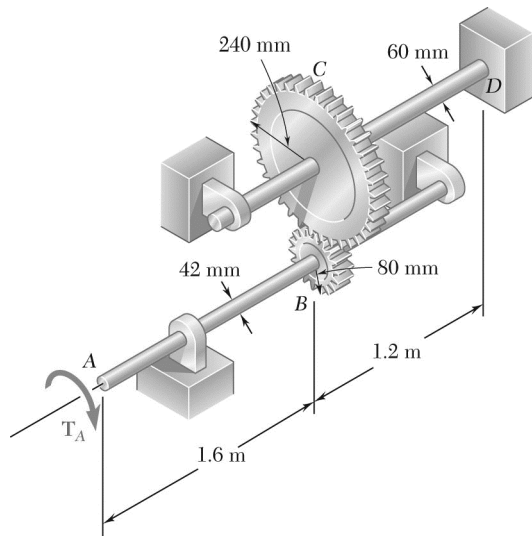

PROBLEM 3.42

Two solid shafts are connected by gears as shown. Knowing that $G = 77.2$ GPa for each shaft, determine the angle through which end A rotates when $T_A = 1200$ N · m.

SOLUTION

Calculation of torques:

Circumferential contact force between gears B and C . $F = \frac{T_{AB}}{r_B} = \frac{T_{CD}}{r_C}$ $T_{CD} = \frac{r_C}{r_B} T_{AB}$

$$T_{AB} = 1200 \text{ N} \cdot \text{m} \quad T_{CD} = \frac{240}{80}(1200) = 3600 \text{ N} \cdot \text{m}$$

Twist in shaft CD :

$$c = \frac{1}{2}d = 0.030 \text{ m}, \quad L = 1.2 \text{ m}, \quad G = 77.2 \times 10^9 \text{ Pa}$$

$$J = \frac{\pi}{2}c^4 = \frac{\pi}{2}(0.030)^4 = 1.27234 \times 10^{-6} \text{ m}^4$$

$$\varphi_{CD} = \frac{TL}{GJ} = \frac{(3600)(1.2)}{(77.2 \times 10^9)(1.27234 \times 10^{-6})} = 43.981 \times 10^{-3} \text{ rad}$$

Rotation angle at C .

$$\varphi_C = \varphi_{CD} = 43.981 \times 10^{-3} \text{ rad}$$

Circumferential displacement at contact points of gears B and C .

$$\delta = r_C \varphi_C = r_B \varphi_B$$

Rotation angle at B .

$$\varphi_B = \frac{r_C}{r_B} \varphi_C = \frac{240}{80}(43.981 \times 10^{-3}) = 131.942 \times 10^{-3} \text{ rad}$$

Twist in shaft AB :

$$c = \frac{1}{2}d = 0.021 \text{ m}, \quad L = 1.6 \text{ m}, \quad G = 77.2 \times 10^9 \text{ Pa}$$

$$J = \frac{\pi}{2}c^4 = \frac{\pi}{2}(0.021)^4 = 305.49 \times 10^{-9} \text{ m}^4$$

$$\varphi_{AB} = \frac{TL}{GJ} = \frac{(1200)(1.6)}{(77.2 \times 10^9)(305.49 \times 10^{-9})} = 81.412 \times 10^{-3} \text{ rad}$$

Rotation angle at A .

$$\varphi_A = \varphi_B + \varphi_{AB} = 213.354 \times 10^{-3} \text{ rad}$$

$$\varphi_A = 12.22^\circ \quad \blacktriangleleft$$

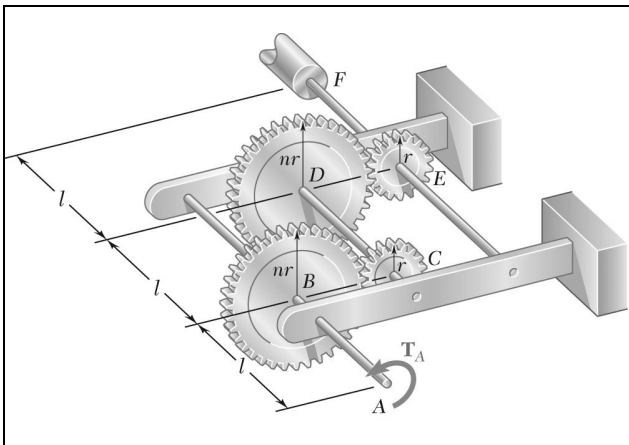

PROBLEM 3.43

A coder F , used to record in digital form the rotation of shaft A , is connected to the shaft by means of the gear train shown, which consists of four gears and three solid steel shafts each of diameter d . Two of the gears have a radius r and the other two a radius nr . If the rotation of the coder F is prevented, determine in terms of T , l , G , J , and n the angle through which end A rotates.

SOLUTION

$$T_{AB} = T_A$$

$$T_{CD} = \frac{r_C}{r_B} T_{AB} = \frac{T_{AB}}{n} = \frac{T_A}{n}$$

$$T_{EF} = \frac{r_E}{r_D} T_{CD} = \frac{T_{CD}}{n} = \frac{T_A}{n^2}$$

$$\varphi_E = \varphi_{EF} = \frac{T_{EF} l_{EF}}{GJ} = \frac{T_A l}{n^2 GJ}$$

$$\varphi_D = \frac{r_E}{r_D} \varphi_E = \frac{\varphi_E}{n} = \frac{T_A l}{n^3 GJ}$$

$$\varphi_{CD} = \frac{T_{CD} l_{CD}}{GJ} = \frac{T_A l}{n GJ}$$

$$\varphi_C = \varphi_D + \varphi_{CD} = \frac{T_A l}{n^3 GJ} + \frac{T_A l}{n GJ} = \frac{T_A l}{GJ} \left(\frac{1}{n^3} + \frac{1}{n} \right)$$

$$\varphi_B = \frac{r_C}{r_B} \varphi_C = \frac{\varphi_C}{n} = \frac{T_A l}{GJ} \left(\frac{1}{n^4} + \frac{1}{n^2} \right)$$

$$\varphi_{AB} = \frac{T_{AB} l_{AB}}{GJ} = \frac{T_A l}{GJ}$$

$$\varphi_A = \varphi_B + \varphi_{AB} = \frac{T_A l}{GJ} \left(\frac{1}{n^4} + \frac{1}{n^2} + 1 \right)$$

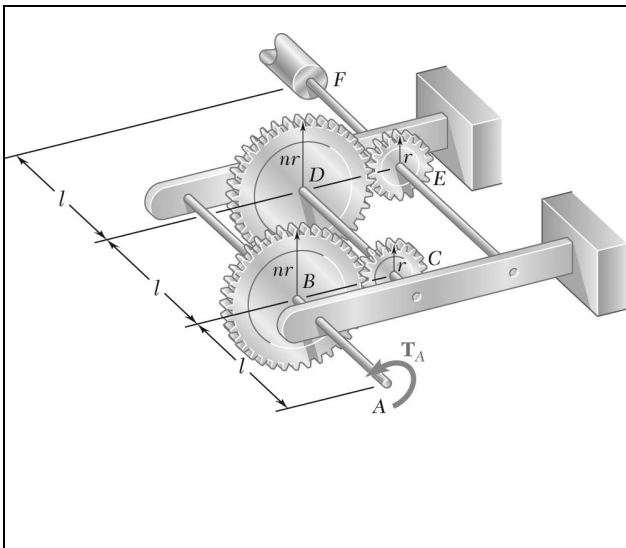

PROBLEM 3.44

For the gear train described in Prob. 3.43, determine the angle through which end A rotates when $T = 5 \text{ lb} \cdot \text{in.}$, $l = 2.4 \text{ in.}$, $d = 1/16 \text{ in.}$, $G = 11.2 \times 10^6 \text{ psi}$, and $n = 2$.

PROBLEM 3.43 A coder F , used to record in digital form the rotation of shaft A , is connected to the shaft by means of the gear train shown, which consists of four gears and three solid steel shafts each of diameter d . Two of the gears have a radius r and the other two a radius nr . If the rotation of the coder F is prevented, determine in terms of T , l , G , J , and n the angle through which end A rotates.

SOLUTION

See solution to Prob. 3.43 for development of equation for ϕ_A .

$$\phi_A = \frac{Tl}{GJ} \left(1 + \frac{1}{n^2} + \frac{1}{n^4} \right)$$

Data: $T = 5 \text{ lb} \cdot \text{in.}$, $l = 2.4 \text{ in.}$, $c = \frac{1}{2}d = \frac{1}{32} \text{ in.}$, $G = 11.2 \times 10^6 \text{ psi}$

$$n = 2, \quad J = \frac{\pi}{2}c^4 = \frac{\pi}{2} \left(\frac{1}{32} \right)^4 = 1.49803 \times 10^{-6} \text{ in}^4$$

$$\phi_A = \frac{(5)(2.4)}{(11.2 \times 10^6)(1.49803 \times 10^{-6})} \left(1 + \frac{1}{4} + \frac{1}{16} \right) = 938.73 \times 10^{-3} \text{ rad} \quad \phi_A = 53.8^\circ \blacktriangleleft$$

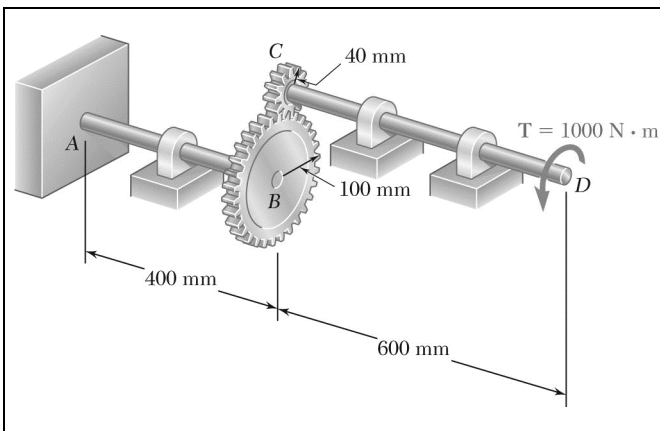

PROBLEM 3.45

The design of the gear-and-shaft system shown requires that steel shafts of the same diameter be used for both AB and CD . It is further required that $\tau_{\max} \leq 60$ MPa, and that the angle ϕ_D through which end D of shaft CD rotates not exceed 1.5° . Knowing that $G = 77$ GPa, determine the required diameter of the shafts.

SOLUTION

$$T_{CD} = T_D = 1000 \text{ N} \cdot \text{m} \quad T_{AB} = \frac{r_B}{r_C} T_{CD} = \frac{100}{40}(1000) = 2500 \text{ N} \cdot \text{m}$$

For design based on stress, use larger torque. $T_{AB} = 2500 \text{ N} \cdot \text{m}$

$$\tau = \frac{Tc}{J} = \frac{2T}{\pi c^3}$$

$$c^3 = \frac{2T}{\pi\tau} = \frac{(2)(2500)}{\pi(60 \times 10^6)} = 26.526 \times 10^{-6} \text{ m}^3$$

$$c = 29.82 \times 10^{-3} \text{ m} = 29.82 \text{ mm}, \quad d = 2c = 59.6 \text{ mm}$$

Design based on rotation angle.

$$\phi_D = 1.5^\circ = 26.18 \times 10^{-3} \text{ rad}$$

Shaft AB :

$$T_{AB} = 2500 \text{ N} \cdot \text{m}, \quad L = 0.4 \text{ m}$$

$$\phi_{AB} = \frac{TL}{GJ} = \frac{(2500)(0.4)}{GJ} = \frac{1000}{GJ}$$

$$\text{Gears} \begin{cases} \phi_B = \phi_{AB} = \frac{1000}{GJ} \\ \phi_C = \frac{r_B}{r_C} \phi_B = \left(\frac{100}{40}\right) \left(\frac{1000}{GJ}\right) = \frac{2500}{GJ} \end{cases}$$

Shaft CD :

$$T_{CD} = 1000 \text{ N} \cdot \text{m}, \quad L = 0.6 \text{ m}$$

$$\phi_{CD} = \frac{TL}{GJ} = \frac{(1000)(0.6)}{GJ} = \frac{600}{GJ}$$

$$\phi_D = \phi_C + \phi_{CD} = \frac{2500}{GJ} + \frac{600}{GJ} = \frac{3100}{GJ} = \frac{3100}{G \frac{\pi}{2} c^4}$$

$$c^4 = \frac{(2)(3100)}{\pi G \phi_D} = \frac{(2)(3100)}{\pi(77 \times 10^9)(26.18 \times 10^{-3})} = 979.06 \times 10^{-9} \text{ m}^4$$

$$c = 31.46 \times 10^{-3} \text{ m} = 31.46 \text{ mm}, \quad d = 2c = 62.9 \text{ mm}$$

Design must use larger value for d .

$$d = 62.9 \text{ mm} \blacktriangleleft$$

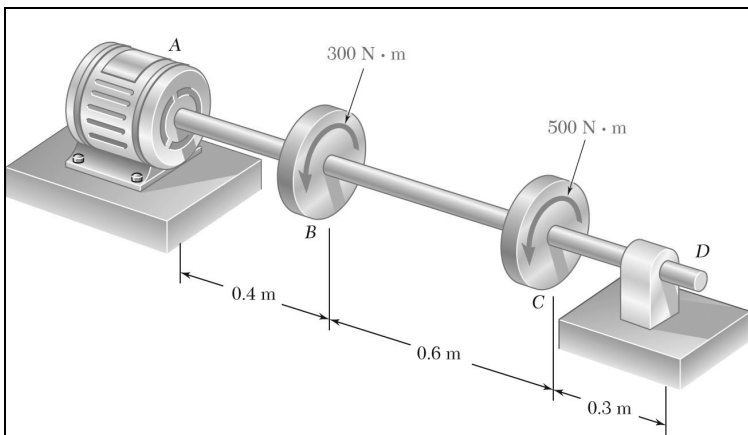

PROBLEM 3.46

The electric motor exerts a torque of 800 N · m on the steel shaft *ABCD* when it is rotating at constant speed. Design specifications require that the diameter of the shaft be uniform from *A* to *D* and that the angle of twist between *A* to *D* not exceed 1.5°. Knowing that $\tau_{\max} \leq 60$ MPa and $G = 77$ GPa, determine the minimum diameter shaft that can be used.

SOLUTION

Torques:

$$T_{AB} = 300 + 500 = 800 \text{ N} \cdot \text{m}$$

$$T_{BC} = 500 \text{ N} \cdot \text{m}, \quad T_{CD} = 0$$

Design based on stress.

$$\tau = 60 \times 10^6 \text{ Pa}$$

$$\tau = \frac{Tc}{J} = \frac{2T}{\pi c^3} \quad c^3 = \frac{2T}{\pi \tau} = \frac{(2)(800)}{\pi(60 \times 10^6)} = 8.488 \times 10^{-6} \text{ m}^3$$

$$c = 20.40 \times 10^{-3} \text{ m} = 20.40 \text{ mm}, \quad d = 2c = 40.8 \text{ mm}$$

Design based on deformation.

$$\phi_{D/A} = 1.5^\circ = 26.18 \times 10^{-3} \text{ rad}$$

$$\phi_{D/C} = 0$$

$$\phi_{C/B} = \frac{T_{BC}L_{BC}}{GJ} = \frac{(500)(0.6)}{GJ} = \frac{300}{GJ}$$

$$\phi_{B/A} = \frac{T_{AB}L_{AB}}{GJ} = \frac{(800)(0.4)}{GJ} = \frac{320}{GJ}$$

$$\phi_{D/A} = \phi_{D/C} + \phi_{C/B} + \phi_{B/A} = \frac{620}{GJ} = \frac{620}{G \frac{\pi}{2} c^4} = \frac{(2)(620)}{\pi G c^4}$$

$$c^4 = \frac{(2)(620)}{\pi G \phi_{D/A}} = \frac{(2)(620)}{\pi(77 \times 10^9)(26.18 \times 10^{-3})} = 195.80 \times 10^{-9} \text{ m}^4$$

$$c = 21.04 \times 10^{-3} \text{ m} = 21.04 \text{ mm}, \quad d = 2c = 42.1 \text{ mm}$$

Design must use larger value of *d*.

$$d = 42.1 \text{ mm} \blacktriangleleft$$

PROBLEM 3.47

The design specifications of a 2-m-long solid circular transmission shaft require that the angle of twist of the shaft not exceed 3° when a torque of $9 \text{ kN} \cdot \text{m}$ is applied. Determine the required diameter of the shaft, knowing that the shaft is made of (a) a steel with an allowable shearing stress of 90 MPa and a modulus of rigidity of 77 GPa , (b) a bronze with an allowable shearing stress of 35 MPa and a modulus of rigidity of 42 GPa .

SOLUTION

$$\varphi = 3^\circ = 52.360 \times 10^{-3} \text{ rad}, \quad T = 9 \times 10^3 \text{ N} \cdot \text{m} \quad L = 2.0 \text{ m}$$

$$\varphi = \frac{TL}{GJ} = \frac{2TL}{\pi c^4 G} \quad \therefore c^4 = \frac{2TL}{\pi G \varphi} \quad \text{based on twist angle.}$$

$$\tau = \frac{Tc}{J} = \frac{2T}{\pi c^2} \quad \therefore c^3 = \frac{2T}{\pi \tau} \quad \text{based on shearing stress.}$$

(a) Steel shaft:

$$\tau = 90 \times 10^6 \text{ Pa}, \quad G = 77 \times 10^9 \text{ Pa}$$

Based on twist angle,
$$c^4 = \frac{(2)(9 \times 10^3)(2.0)}{\pi(77 \times 10^9)(52.360 \times 10^{-3})} = 2.842 \times 10^{-6} \text{ m}^4$$

$$c = 41.06 \times 10^{-3} \text{ m} = 41.06 \text{ mm} \quad d = 2c = 82.1 \text{ mm}$$

Based on shearing stress,
$$c^3 = \frac{(2)(9 \times 10^3)}{\pi(90 \times 10^6)} = 63.662 \times 10^{-6} \text{ m}^3$$

$$c = 39.93 \times 10^{-3} \text{ m} = 39.93 \text{ mm} \quad d = 2c = 79.9 \text{ mm}$$

Required value of d is the larger.

$$d = 82.1 \text{ mm} \quad \blacktriangleleft$$

(b) Bronze shaft:

$$\tau = 35 \times 10^6 \text{ Pa}, \quad G = 42 \times 10^9 \text{ Pa}$$

Based on twist angle,
$$c^4 = \frac{(2)(9 \times 10^3)(2.0)}{\pi(42 \times 10^9)(52.360 \times 10^{-3})} = 5.2103 \times 10^{-6} \text{ m}^4$$

$$c = 47.78 \times 10^{-3} \text{ m} = 47.78 \text{ mm} \quad d = 2c = 95.6 \text{ mm}$$

Based on shearing stress,
$$c^3 = \frac{(2)(9 \times 10^3)}{\pi(35 \times 10^6)} = 163.702 \times 10^{-6} \text{ m}^3$$

$$c = 54.70 \times 10^{-3} \text{ m} = 54.70 \text{ mm} \quad d = 2c = 109.4 \text{ mm}$$

Required value of d is the larger.

$$d = 109.4 \text{ mm} \quad \blacktriangleleft$$

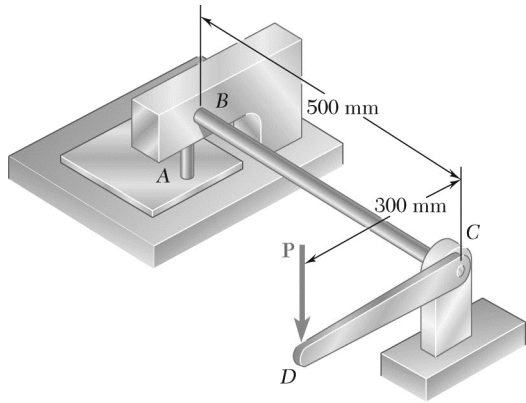

PROBLEM 3.48

A hole is punched at A in a plastic sheet by applying a 600-N force P to end D of lever CD , which is rigidly attached to the solid cylindrical shaft BC . Design specifications require that the displacement of D should not exceed 15 mm from the time the punch first touches the plastic sheet to the time it actually penetrates it. Determine the required diameter of shaft BC if the shaft is made of a steel with $G = 77 \text{ GPa}$ and $\tau_{\text{all}} = 80 \text{ MPa}$.

SOLUTION

Torque $T = rP = (0.300 \text{ m})(600 \text{ N}) = 180 \text{ N} \cdot \text{m}$

Shaft diameter based on displacement limit.

$$\varphi = \frac{\delta}{r} = \frac{15 \text{ mm}}{300 \text{ mm}} = 0.005 \text{ rad}$$

$$\varphi = \frac{TL}{GJ} = \frac{2TL}{\pi Gc^4}$$

$$c^4 = \frac{2TL}{\pi G\varphi} = \frac{(2)(180)(0.500)}{\pi(77 \times 10^9)(0.005)} = 14.882 \times 10^{-9} \text{ m}^4$$

$$c = 11.045 \times 10^{-3} \text{ m} = 11.045 \text{ mm} \quad d = 2c = 22.1 \text{ mm}$$

Shaft diameter based on stress.

$$\tau = 80 \times 10^6 \text{ Pa} \quad \tau = \frac{Tc}{J} = \frac{2T}{\pi c^3}$$

$$c^3 = \frac{2T}{\pi\tau} = \frac{(2)(180)}{\pi(80 \times 10^6)} = 1.43239 \times 10^{-6} \text{ m}^3$$

$$c = 11.273 \times 10^{-3} \text{ m} = 11.273 \text{ mm} \quad d = 2c = 22.5 \text{ mm}$$

Use the larger value to meet both limits.

$$d = 22.5 \text{ mm} \quad \blacktriangleleft$$

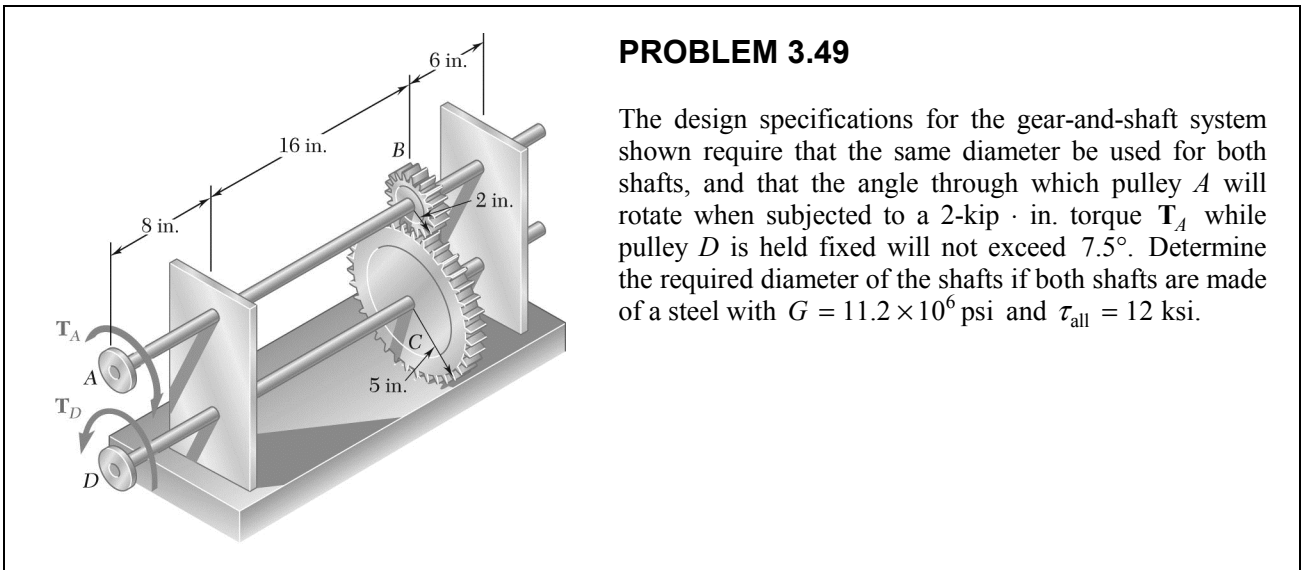

PROBLEM 3.49

The design specifications for the gear-and-shaft system shown require that the same diameter be used for both shafts, and that the angle through which pulley A will rotate when subjected to a 2-kip · in. torque T_A while pulley D is held fixed will not exceed 7.5° . Determine the required diameter of the shafts if both shafts are made of a steel with $G = 11.2 \times 10^6$ psi and $\tau_{\text{all}} = 12$ ksi.

SOLUTION

Statics:

Gear B.

$$+\circlearrowleft \Sigma M_B = 0:$$

$$r_B F - T_A = 0 \quad F = T_B / r_B$$

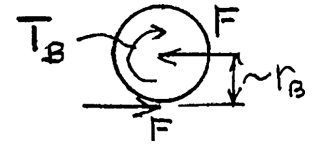

Gear C.

$$+\circlearrowleft \Sigma M_C = 0:$$

$$r_C F - T_D = 0$$

$$T_D = r_C F = \frac{r_C}{r_B} T_A = n T_B$$

$$n = \frac{r_C}{r_B} = \frac{5}{2} = 2.5$$

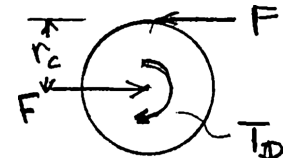

Torques in shafts.

$$T_{AB} = T_A = T_B \quad T_{CD} = T_C = n T_B = n T_A$$

Deformations:

$$\phi_{C/D} = \frac{T_{CD} L}{GJ} \curvearrowright = \frac{n T_A L}{GJ} \curvearrowright$$

$$\phi_{A/B} = \frac{T_{AB} L}{GJ} \curvearrowleft = \frac{T_A L}{GJ} \curvearrowleft$$

Kinematics:

$$\phi_D = 0 \quad \phi_C = \phi_D + \phi_{C/D} = 0 + \frac{n T_A L}{GJ} \curvearrowright$$

$$r_B \phi_B = -r_C \phi_C \quad \phi_B = -\frac{r_C}{r_B} \phi_C = -n \phi_C \quad \phi_B \frac{n^2 T_A L}{GJ} \curvearrowright$$

$$\phi_A = \phi_C + \phi_{B/C} = \frac{n^2 T_A L}{GJ} + \frac{T_A L}{GJ} = \frac{(n^2 + 1) T_A L}{GJ} \curvearrowright$$

PROBLEM 3.49 (Continued)

Diameter based on stress.

Largest torque:

$$T_m = T_{CD} = nT_A$$

$$\tau_m = \frac{T_m c}{J} = \frac{2nT_A}{\pi c^3} \quad \tau_m = \tau_{\text{all}} = 12 \times 10^3 \text{ psi}, \quad T_A = 2 \times 10^3 \text{ lb} \cdot \text{in}$$

$$c = \sqrt[3]{\frac{2nT_A}{\pi \tau_m}} = \sqrt[3]{\frac{(2)(2.5)(2 \times 10^3)}{\pi(12 \times 10^3)}} = 0.6425 \text{ in.}, \quad d = 2c = 1.285 \text{ in.}$$

Diameter based on rotation limit.

$$\varphi = 7.5^\circ = 0.1309 \text{ rad}$$

$$\varphi = \frac{(n^2 + 1)T_A L}{GJ} = \frac{(2)(7.25)T_A L}{\pi c^4 G} \quad L = 8 + 16 = 24 \text{ in.}$$

$$c = \sqrt[4]{\frac{(2)(7.25)T_A L}{\pi G \varphi}} = \sqrt[4]{\frac{(2)(7.25)(2 \times 10^3)(24)}{\pi(11.2 \times 10^6)(0.1309)}} = 0.62348 \text{ in.}, \quad d = 2c = 1.247 \text{ in.}$$

Choose the larger diameter.

$$d = 1.285 \text{ in.} \quad \blacktriangleleft$$

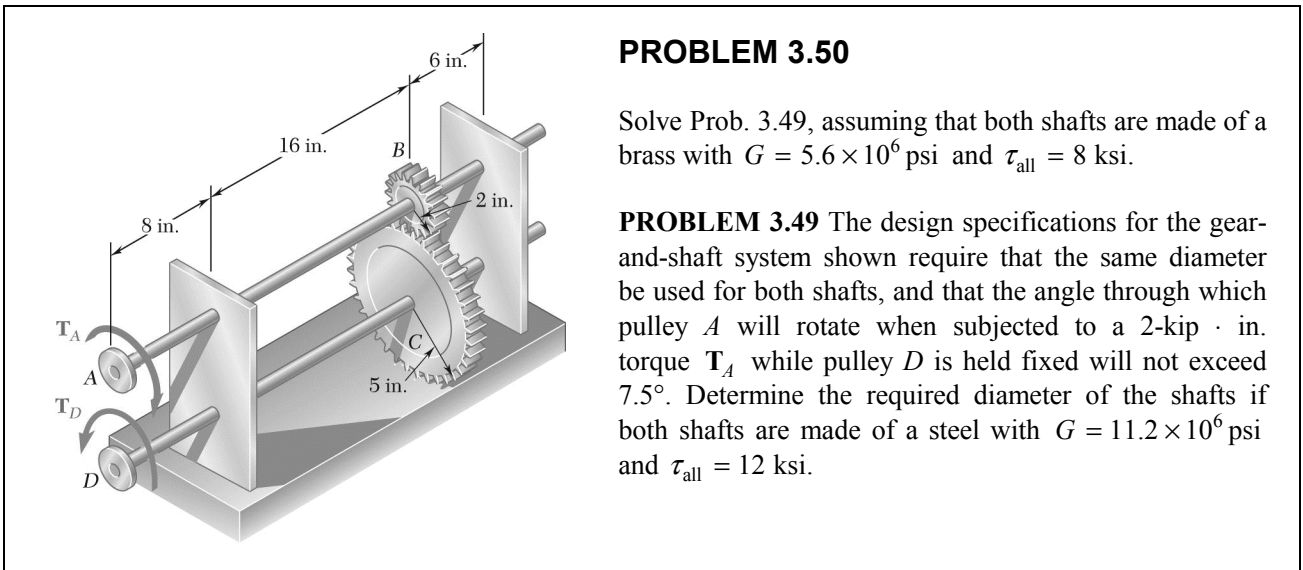

PROBLEM 3.50

Solve Prob. 3.49, assuming that both shafts are made of a brass with $G = 5.6 \times 10^6$ psi and $\tau_{all} = 8$ ksi.

PROBLEM 3.49 The design specifications for the gear-and-shaft system shown require that the same diameter be used for both shafts, and that the angle through which pulley A will rotate when subjected to a 2-kip · in. torque T_A while pulley D is held fixed will not exceed 7.5° . Determine the required diameter of the shafts if both shafts are made of a steel with $G = 11.2 \times 10^6$ psi and $\tau_{all} = 12$ ksi.

SOLUTION

Statics:

Gear B.

$$\begin{aligned} +\curvearrowright \Sigma M_B &= 0: \\ r_B F - T_A &= 0 \quad F = T_B / r_B \end{aligned}$$

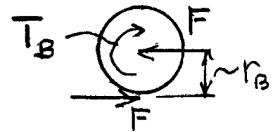

Gear C.

$$\begin{aligned} +\curvearrowright \Sigma M_C &= 0: \\ r_C F - T_D &= 0 \\ T_D = r_C F &= \frac{r_C}{r_B} T_A = n T_B \end{aligned}$$

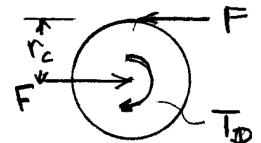

$$n = \frac{r_C}{r_B} = \frac{5}{2} = 2.5$$

Torques in shafts.

$$T_{AB} = T_A = T_B \quad T_{CD} = T_C = n T_B = n T_A$$

Deformations:

$$\begin{aligned} \phi_{C/D} &= \frac{T_{CD} L}{GJ} \curvearrowright = \frac{n T_A L}{GJ} \curvearrowright \\ \phi_{A/B} &= \frac{T_{AB} L}{GJ} \curvearrowleft = \frac{T_A L}{GJ} \curvearrowleft \end{aligned}$$

Kinematics:

$$\begin{aligned} \phi_D &= 0 \quad \phi_C = \phi_D + \phi_{C/D} = 0 + \frac{n T_A L}{GJ} \curvearrowright \\ r_B \phi_B &= -r_C \phi_C \quad \phi_B = -\frac{r_C}{r_B} \phi_C = -n \phi_C \quad \phi_B \frac{n^2 T_A L}{GJ} \curvearrowright \\ \phi_A &= \phi_C + \phi_{B/C} = \frac{n^2 T_A L}{GJ} + \frac{T_A L}{GJ} = \frac{(n^2 + 1) T_A L}{GJ} \curvearrowright \end{aligned}$$

PROBLEM 3.50 (Continued)

Diameter based on stress.

Largest torque:

$$T_m = T_{CD} = nT_A$$

$$\tau_m = \frac{T_m c}{J} = \frac{2nT_A}{\pi c^3} \quad \tau_m = \tau_{\text{all}} = 8 \times 10^3 \text{ psi}, \quad T_A = 2 \times 10^3 \text{ lb} \cdot \text{in}$$

$$c = \sqrt[3]{\frac{2nT_A}{\pi \tau_m}} = \sqrt[3]{\frac{(2)(2.5)(2 \times 10^3)}{\pi(8 \times 10^3)}} = 0.7355 \text{ in.}, \quad d = 2c = 1.471 \text{ in.}$$

Diameter based on rotation limit.

$$\varphi = 7.5^\circ = 0.1309 \text{ rad}$$

$$\varphi = \frac{(n^2 + 1)T_A L}{GJ} = \frac{(2)(7.25)T_A L}{\pi c^4 G} \quad L = 8 + 16 = 24 \text{ in.}$$

$$c = \sqrt[4]{\frac{(2)(7.25)T_A L}{\pi G \varphi}} = \sqrt[4]{\frac{(2)(7.25)(2 \times 10^3)(24)}{\pi(5.6 \times 10^6)(0.1309)}} = 0.7415 \text{ in.}, \quad d = 2c = 1.483 \text{ in.}$$

Choose the larger diameter.

$$d = 1.483 \text{ in.} \quad \blacktriangleleft$$

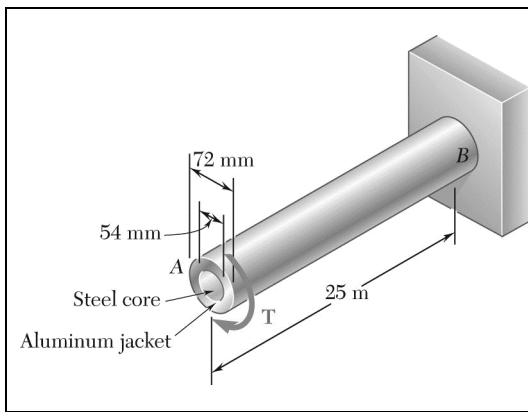

PROBLEM 3.51

A torque of magnitude $T = 4 \text{ kN}\cdot\text{m}$ is applied at end A of the composite shaft shown. Knowing that the modulus of rigidity is 77 GPa for the steel and 27 GPa for the aluminum, determine (a) the maximum shearing stress in the steel core, (b) the maximum shearing stress in the aluminum jacket, (c) the angle of twist at A .

SOLUTION

Steel core: $c_1 = \frac{1}{2}d_1 = 0.027 \text{ m} \quad J_1 = \frac{\pi}{2}c_1^4 = \frac{\pi}{2}(0.027)^4 = 834.79 \times 10^{-9}$

$$G_1J_1 = (77 \times 10^9)(834.79 \times 10^{-9}) = 64.28 \times 10^3 \text{ N}\cdot\text{m}^2$$

Torque carried by steel core. $T_1 = G_1J_1\phi/L$

Aluminum jacket: $c_1 = \frac{1}{2}d_1 = 0.027 \text{ m}, \quad c_2 = \frac{1}{2}d_2 = 0.036 \text{ m}$

$$J_2 = \frac{\pi}{2}(c_2^4 - c_1^4) = \frac{\pi}{2}(0.036^4 - 0.027^4) = 1.80355 \times 10^{-6} \text{ m}^4$$

$$G_2J_2 = (27 \times 10^9)(1.80355 \times 10^{-6}) = 48.70 \times 10^3 \text{ N}\cdot\text{m}^2$$

Torque carried by aluminum jacket. $T_2 = G_2J_2\phi/L$

Total torque: $T = T_1 + T_2 = (G_1J_1 + G_2J_2)\phi/L$

$$\frac{\phi}{L} = \frac{T}{G_1J_1 + G_2J_2} = \frac{4 \times 10^3}{64.28 \times 10^3 + 48.70 \times 10^3} = 35.406 \times 10^{-3} \text{ rad/m}$$

(a) Maximum shearing stress in steel core.

$$\tau = G_1\gamma = G_1c_1\frac{\phi}{L} = (77 \times 10^9)(0.027)(35.406 \times 10^{-3}) = 73.6 \times 10^6 \text{ Pa} \quad 73.6 \text{ MPa} \quad \blacktriangleleft$$

(b) Maximum shearing stress in aluminum jacket.

$$\tau = G_2\gamma = G_2c_2\frac{\phi}{L} = (27 \times 10^9)(0.036)(35.406 \times 10^{-3}) = 34.4 \times 10^6 \text{ Pa} \quad 34.4 \text{ MPa} \quad \blacktriangleleft$$

(c) Angle of twist. $\phi = L\frac{\phi}{L} = (2.5)(35.406 \times 10^{-3}) = 88.5 \times 10^{-3} \text{ rad} \quad \phi = 5.07^\circ \quad \blacktriangleleft$

PROBLEM 3.52

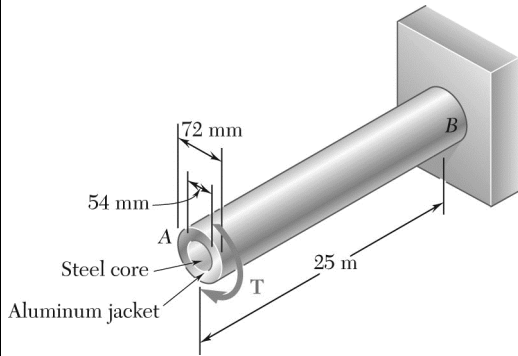

The composite shaft shown is to be twisted by applying a torque T at end A . Knowing that the modulus of rigidity is 77 GPa for the steel and 27 GPa for the aluminum, determine the largest angle through which end A can be rotated if the following allowable stresses are not to be exceeded: $\tau_{\text{steel}} = 60 \text{ MPa}$ and $\tau_{\text{aluminum}} = 45 \text{ MPa}$.

SOLUTION

$$\tau_{\text{max}} = G\gamma_{\text{max}} = Gc_{\text{max}} \frac{\phi}{L}$$

$$\frac{\phi_{\text{all}}}{L} = \frac{\tau_{\text{all}}}{Gc_{\text{max}}} \text{ for each material.}$$

Steel core: $\tau_{\text{all}} = 60 \times 10^6 \text{ Pa}$, $c_{\text{max}} = \frac{1}{2}d = 0.027 \text{ m}$, $G = 77 \times 10^9 \text{ Pa}$

$$\frac{\phi_{\text{all}}}{L} = \frac{60 \times 10^6}{(77 \times 10^9)(0.027)} = 28.860 \times 10^{-3} \text{ rad/m}$$

Aluminum Jacket: $\tau_{\text{all}} = 45 \times 10^6 \text{ Pa}$, $c_{\text{max}} = \frac{1}{2}d = 0.036 \text{ m}$, $G = 27 \times 10^9 \text{ Pa}$

$$\frac{\phi_{\text{all}}}{L} = \frac{45 \times 10^6}{(27 \times 10^9)(0.036)} = 46.296 \times 10^{-3} \text{ rad/m}$$

Smaller value governs: $\frac{\phi_{\text{all}}}{L} = 28.860 \times 10^{-3} \text{ rad/m}$

Allowable angle of twist: $\phi_{\text{all}} = L \frac{\phi_{\text{all}}}{L} = (2.5)(28.860 \times 10^{-3}) = 72.15 \times 10^{-3} \text{ rad}$ $\phi_{\text{all}} = 4.13^\circ \blacktriangleleft$

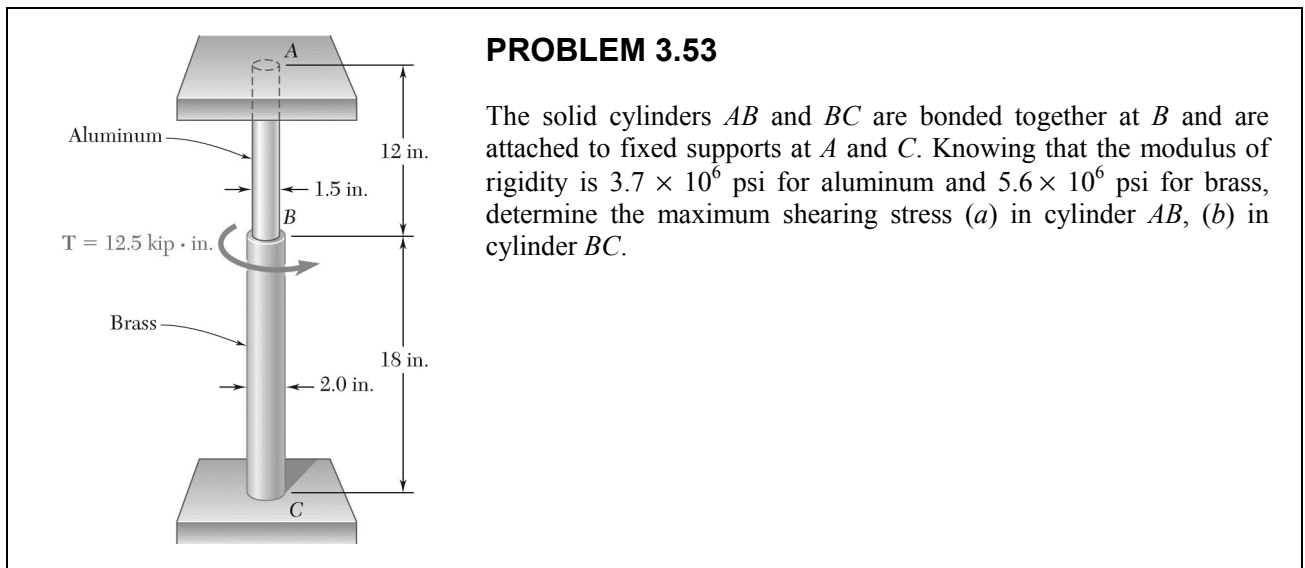

SOLUTION

The torques in cylinders AB and BC are statically indeterminate. Match the rotation ϕ_B for each cylinder.

Cylinder AB : $c = \frac{1}{2}d = 0.75$ in. $L = 12$ in.

$$J = \frac{\pi}{2}c^4 = 0.49701 \text{ in}^4$$

$$\phi_B = \frac{T_{AB}L}{GJ} = \frac{T_{AB}(12)}{(3.7 \times 10^6)(0.49701)} = 6.5255 \times 10^{-6} T_{AB}$$

Cylinder BC : $c = \frac{1}{2}d = 1.0$ in. $L = 18$ in.

$$J = \frac{\pi}{2}c^4 = \frac{\pi}{2}(1.0)^4 = 1.5708 \text{ in}^4$$

$$\phi_B = \frac{T_{BC}L}{GJ} = \frac{T_{BC}(18)}{(5.6 \times 10^6)(1.5708)} = 2.0463 \times 10^{-6} T_{BC}$$

Matching expressions for ϕ_B $6.5255 \times 10^{-6} T_{AB} = 2.0463 \times 10^{-6} T_{BC}$

$$T_{BC} = 3.1889 T_{AB} \tag{1}$$

Equilibrium of connection at B : $T_{AB} + T_{BC} - T = 0$ $T = 12.5 \times 10^3$ lb·in

$$T_{AB} + T_{BC} = 12.5 \times 10^3 \tag{2}$$

PROBLEM 3.53 (Continued)

Substituting (1) into (2), $4.1889 T_{AB} = 12.5 \times 10^3$

$$T_{AB} = 2.9841 \times 10^3 \text{ lb} \cdot \text{in} \quad T_{BC} = 9.5159 \times 10^3 \text{ lb} \cdot \text{in}$$

(a) Maximum stress in cylinder AB.

$$\tau_{AB} = \frac{T_{AB}c}{J} = \frac{(2.9841 \times 10^3)(0.75)}{0.49701} = 4.50 \times 10^3 \text{ psi} \quad \tau_{AB} = 4.50 \text{ ksi} \blacktriangleleft$$

(b) Maximum stress in cylinder BC.

$$\tau_{BC} = \frac{T_{BC}c}{J} = \frac{(9.5159 \times 10^3)(1.0)}{1.5708} = 6.06 \times 10^3 \text{ psi} \quad \tau_{BC} = 6.06 \text{ ksi} \blacktriangleleft$$

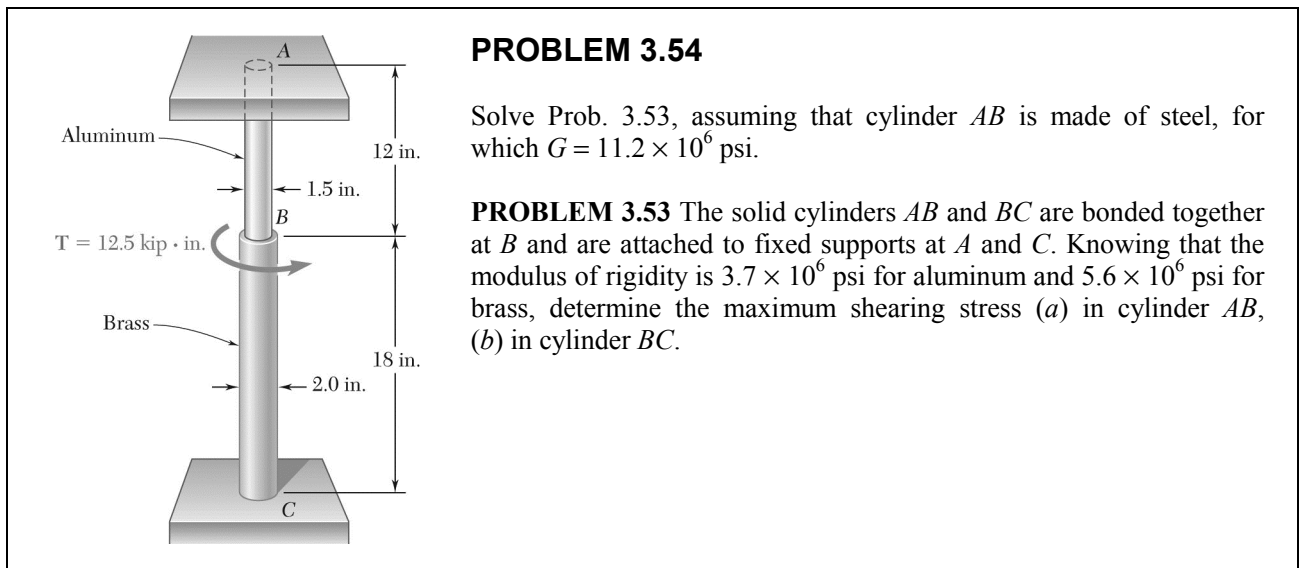

PROBLEM 3.54

Solve Prob. 3.53, assuming that cylinder *AB* is made of steel, for which $G = 11.2 \times 10^6$ psi.

PROBLEM 3.53 The solid cylinders *AB* and *BC* are bonded together at *B* and are attached to fixed supports at *A* and *C*. Knowing that the modulus of rigidity is 3.7×10^6 psi for aluminum and 5.6×10^6 psi for brass, determine the maximum shearing stress (*a*) in cylinder *AB*, (*b*) in cylinder *BC*.

SOLUTION

The torques in cylinders *AB* and *BC* are statically indeterminate. Match the rotation ϕ_B for each cylinder.

Cylinder AB: $c = \frac{1}{2}d = 0.75$ in. $L = 12$ in. $J = \frac{\pi}{2}c^4 = 0.49701$ in⁴

$$\phi_B = \frac{T_{AB}L}{GJ} = \frac{T_{AB}(12)}{(11.2 \times 10^6)(0.49701)} = 2.1557 \times 10^{-6} T_{AB}$$

Cylinder BC: $c = \frac{1}{2}d = 1.0$ in. $L = 18$ in. $J = \frac{\pi}{2}c^4 = \frac{\pi}{2}(1.0)^4 = 1.5708$ in⁴

$$\phi_B = \frac{T_{BC}L}{GJ} = \frac{T_{BC}(18)}{(5.6 \times 10^6)(1.5708)} = 2.0463 \times 10^{-6} T_{BC}$$

Matching expressions for ϕ_B $2.1557 \times 10^{-6} T_{AB} = 2.0463 \times 10^{-6} T_{BC}$ $T_{BC} = 1.0535 T_{AB}$ (1)

Equilibrium of connection at B: $T_{AB} + T_{BC} - T = 0$ $T_{AB} + T_{BC} = 12.5 \times 10^3$ (2)

Substituting (1) into (2), $2.0535 T_{AB} = 12.5 \times 10^3$

$$T_{AB} = 6.0872 \times 10^3 \text{ lb} \cdot \text{in} \quad T_{BC} = 6.4128 \times 10^3 \text{ lb} \cdot \text{in}$$

(a) Maximum stress in cylinder AB.

$$\tau_{AB} = \frac{T_{AB}c}{J} = \frac{(6.0872 \times 10^3)(0.75)}{0.49701} = 9.19 \times 10^3 \text{ psi} \quad \tau_{AB} = 9.19 \text{ ksi} \blacktriangleleft$$

(b) Maximum stress in cylinder BC.

$$\tau_{BC} = \frac{T_{BC}c}{J} = \frac{(6.4128 \times 10^3)(1.0)}{1.5708} = 4.08 \times 10^3 \text{ psi} \quad \tau_{BC} = 4.08 \text{ ksi} \blacktriangleleft$$

PROBLEM 3.55

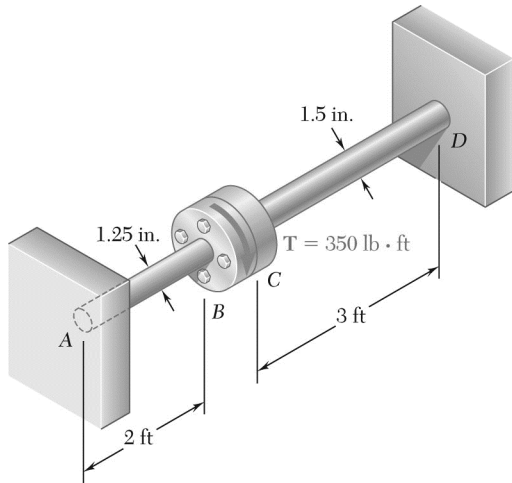

Two solid steel shafts are fitted with flanges that are then connected by bolts as shown. The bolts are slightly undersized and permit a 1.5° rotation of one flange with respect to the other before the flanges begin to rotate as a single unit. Knowing that $G = 11.2 \times 10^6$ psi, determine the maximum shearing stress in each shaft when a torque of T of magnitude 420 kip · ft is applied to the flange indicated.

PROBLEM 3.55 The torque T is applied to flange B .

SOLUTION

Shaft AB:

$$T = T_{AB}, \quad L_{AB} = 2 \text{ ft} = 24 \text{ in.}, \quad c = \frac{1}{2}d = 0.625 \text{ in.}$$

$$J_{AB} = \frac{\pi}{2}c^4 = \frac{\pi}{2}(0.625)^4 = 0.23968 \text{ in}^4$$

$$\varphi_B = \frac{T_{AB}L_{AB}}{GJ_{AB}}$$

$$T_{AB} = \frac{GJ_{AB}\varphi_B}{L_{AB}} = \frac{(11.2 \times 10^6)(0.23968)}{24}\varphi_B$$
$$= 111.853 \times 10^3 \varphi_B$$

Shaft CD:

Applied torque: $T = 420 \text{ kip} \cdot \text{ft} = 5040 \text{ lb} \cdot \text{in}$

$$T = T_{CD}, \quad L_{CD} = 3 \text{ ft} = 36 \text{ in.}, \quad c = \frac{1}{2}d = 0.75 \text{ in.}$$

$$J_{CD} = \frac{\pi}{2}c^4 = \frac{\pi}{2}(0.75)^4 = 0.49701 \text{ in}^4$$

$$\varphi_C = \frac{T_{CD}L_{CD}}{GJ_{CD}}$$

$$T_{CD} = \frac{GJ_{CD}\varphi_C}{L_{CD}} = \frac{(11.2 \times 10^6)(0.49701)}{36}\varphi_C = 154.625 \times 10^3 \varphi_C$$

PROBLEM 3.55 (Continued)

Clearance rotation for flange B : $\phi'_B = 1.5^\circ = 26.18 \times 10^{-3} \text{ rad}$

Torque to remove clearance: $T'_{AB} = (111.853 \times 10^3)(26.18 \times 10^{-3}) = 2928.3 \text{ lb} \cdot \text{in}$

Torque T'' to cause additional rotation ϕ'' : $T'' = 5040 - 2928.3 = 2111.7 \text{ lb} \cdot \text{in}$

$$T'' = T''_{AB} + T''_{CD}$$

$$2111.7 = (111.853 \times 10^3)\phi'' + (154.625 \times 10^3)\phi'' \quad \therefore \phi'' = 7.923 \times 10^{-3} \text{ rad}$$

$$T''_{AB} = (111.853 \times 10^3)(7.923 \times 10^{-3}) = 886.21 \text{ lb} \cdot \text{in}$$

$$T''_{CD} = (154.625 \times 10^3)(7.923 \times 10^{-3}) = 1225.09 \text{ lb} \cdot \text{in}$$

Maximum shearing stress in AB .

$$\tau_{AB} = \frac{T_{AB}c}{J_{AB}} = \frac{(2928.3 + 886.21)(0.625)}{0.23968} = 9950 \text{ psi} \quad \tau_{AB} = 9.95 \text{ ksi} \quad \blacktriangleleft$$

Maximum shearing stress in CD .

$$\tau_{CD} = \frac{T_{CD}c}{J_{CD}} = \frac{(1225.09)(0.75)}{0.49701} = 1849 \text{ psi} \quad \tau_{CD} = 1.849 \text{ ksi} \quad \blacktriangleleft$$

PROBLEM 3.56

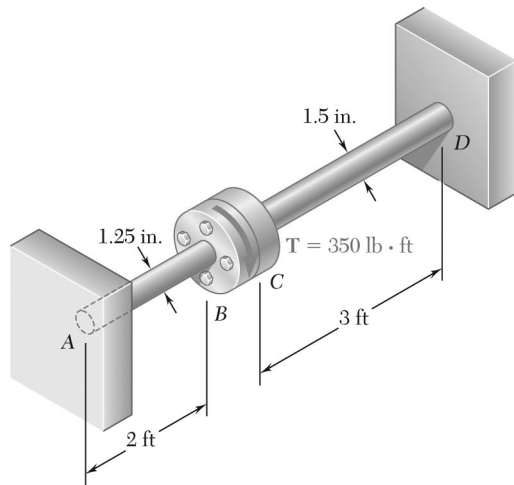

Two solid steel shafts are fitted with flanges that are then connected by bolts as shown. The bolts are slightly undersized and permit a 1.5° rotation of one flange with respect to the other before the flanges begin to rotate as a single unit. Knowing that $G = 11.2 \times 10^6$ psi, determine the maximum shearing stress in each shaft when a torque of T of magnitude 420 kip · ft is applied to the flange indicated.

PROBLEM 3.56 The torque T is applied to flange C .

SOLUTION

Shaft AB:

$$T = T_{AB}, \quad L_{AB} = 2 \text{ ft} = 24 \text{ in.}, \quad c = \frac{1}{2}d = 0.625 \text{ in.}$$

$$J_{AB} = \frac{\pi}{2}c^4 = \frac{\pi}{2}(0.625)^4 = 0.23968 \text{ in}^4$$

$$\phi_B = \frac{T_{AB}L_{AB}}{GJ_{AB}}$$

$$T_{AB} = \frac{GJ_{AB}\phi_B}{L_{AB}} = \frac{(11.2 \times 10^6)(0.23968)}{24}\phi_B$$
$$= 111.853 \times 10^3 \phi_B$$

Shaft CD:

Applied torque: $T = 420 \text{ kip} \cdot \text{ft} = 5040 \text{ lb} \cdot \text{in}$

$$T = T_{CD}, \quad L_{CD} = 3 \text{ ft} = 36 \text{ in.}, \quad c = \frac{1}{2}d = 0.75 \text{ in.}$$

$$J_{CD} = \frac{\pi}{2}c^4 = \frac{\pi}{2}(0.75)^4 = 0.49701 \text{ in}^4$$

$$\phi_C = \frac{T_{CD}L_{CD}}{GJ_{CD}}$$

$$T_{CD} = \frac{GJ_{CD}\phi_C}{L_{CD}} = \frac{(11.2 \times 10^6)(0.49701)}{36}\phi_C = 154.625 \times 10^3 \phi_C$$

Clearance rotation for flange C : $\phi'_C = 1.5^\circ = 26.18 \times 10^{-3} \text{ rad}$

PROBLEM 3.56 (Continued)

Torque to remove clearance: $T'_{CD} = (154.625 \times 10^3)(26.18 \times 10^{-3}) = 4048.1 \text{ lb} \cdot \text{in}$

Torque T'' to cause additional rotation ϕ'' : $T'' = 5040 - 4048.1 = 991.9 \text{ lb} \cdot \text{in}$

$$T'' = T''_{AB} + T''_{CD}$$

$$991.9 = (111.853 \times 10^3)\phi'' + (154.625 \times 10^3)\phi'' \quad \therefore \quad \phi'' = 3.7223 \times 10^{-3} \text{ rad}$$

$$T''_{AB} = (111.853 \times 10^3)(3.7223 \times 10^{-3}) = 416.35 \text{ lb} \cdot \text{in}$$

$$T''_{CD} = (154.625 \times 10^3)(3.7223 \times 10^{-3}) = 575.56 \text{ lb} \cdot \text{in}$$

Maximum shearing stress in AB.

$$\tau_{AB} = \frac{T_{AB}c}{J_{AB}} = \frac{(416.35)(0.625)}{0.23968} = 1086 \text{ psi} \qquad \tau_{AB} = 1.086 \text{ ksi} \blacktriangleleft$$

Maximum shearing stress in CD.

$$\tau_{CD} = \frac{T_{CD}c}{J_{CD}} = \frac{(4048.1 + 575.56)(0.75)}{0.49701} = 6980 \text{ psi} \qquad \tau_{CD} = 6.98 \text{ ksi} \blacktriangleleft$$

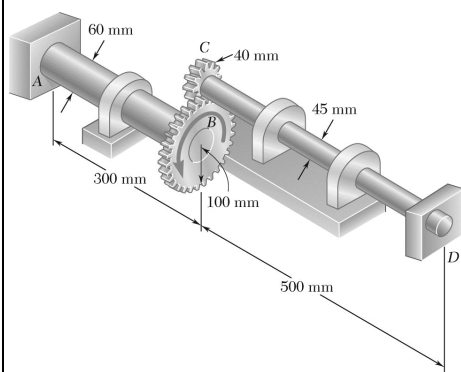

PROBLEM 3.57

Ends A and D of two solid steel shafts AB and CD are fixed, while ends B and C are connected to gears as shown. Knowing that a $4\text{-kN}\cdot\text{m}$ torque T is applied to gear B , determine the maximum shearing stress (a) in shaft AB , (b) in shaft CD .

SOLUTION

Gears B and C :

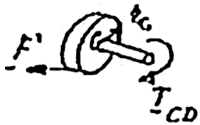

$$\phi_B = \frac{r_C}{r_B} \phi_C = \frac{40}{100} \phi_C \quad \phi_B = 0.4 \phi_C \quad (1)$$

$$\sum M_C = 0 : T_{CD} = r_C F \quad (2)$$

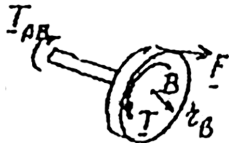

$$\sum M_B = 0 : T - T_{AB} = r_B F \quad (3)$$

Solve (2) for F and substitute into (3):

$$T - T_{AB} = \frac{r_B}{r_C} T_{CD} \quad T = T_{AB} + \frac{100}{40} T_{CD} \quad (4)$$

$$T = T_{AB} + 2.5 T_{CD}$$

Shaft AB :

$$L = 0.3 \text{ m}, \quad c = 0.030 \text{ m}$$

$$\phi_B = \phi_{B/A} = \frac{T_{AB} L}{JG} = \frac{T_{AB} (0.3)}{\frac{\pi}{2} (0.030)^4 G} = 235.79 \times 10^3 \frac{T_{AB}}{G} \quad (5)$$

Shaft CD :

$$L = 0.5 \text{ m}, \quad c = 0.0225 \text{ m}$$

$$\phi_C = \phi_{C/D} = \frac{T_{CD} L}{JG} = \frac{T_{CD} (0.5)}{\frac{\pi}{2} (0.0225)^4 G} = 1242 \times 10^3 \frac{T_{CD}}{G} \quad (6)$$

Substitute from (5) and (6) into (1):

$$\phi_B = 0.4 \phi_C : \quad 235.79 \times 10^3 \frac{T_{AB}}{G} = 0.4 \times 1242 \times 10^3 \frac{T_{CD}}{G}$$

$$T_{CD} = 0.47462 = T_{AB} \quad (7)$$

PROBLEM 3.57 (Continued)

Substitute for T_{CD} from (7) into (4):

$$T = T_{AB} + 2.5(0.47462T_{AB}) \qquad T = 2.1865T_{AB} \quad (8)$$

For $T = 4 \text{ kN} \cdot \text{m}$, Eq. (8) yields

$$4000 \text{ N} \cdot \text{m} = 2.1865T_{AB} \qquad T_{AB} = 1829.4 \text{ N} \cdot \text{m}$$

Substitute into (7):

$$T_{CD} = 0.47462(1829.4) = 868.3 \text{ N} \cdot \text{m}$$

(a) Stress in AB:

$$\tau_{AB} = \frac{T_{AB}c}{J} = \frac{2}{\pi} \frac{T_{AB}}{c^3} = \frac{2}{\pi} \frac{1829.4}{(0.030)^3} = 43.1 \times 10^6 \qquad \tau_{AB} = 43.1 \text{ MPa} \quad \blacktriangleleft$$

(b) Stress in CD:

$$\tau_{CD} = \frac{T_{CD}c}{J} = \frac{2}{\pi} \frac{T_{CD}}{c^3} = \frac{2}{\pi} \frac{868.3}{(0.0225)^3} = 48.5 \times 10^6 \qquad \tau_{CD} = 48.5 \text{ MPa} \quad \blacktriangleleft$$

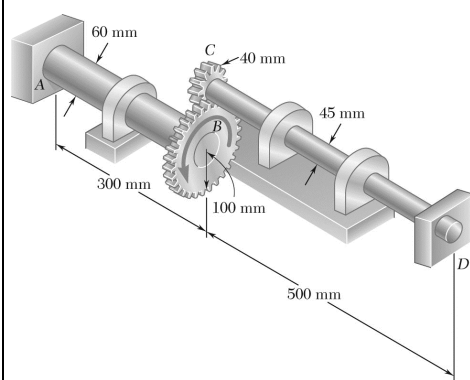

PROBLEM 3.58

Ends A and D of the two solid steel shafts AB and CD are fixed, while ends B and C are connected to gears as shown. Knowing that the allowable shearing stress is 50 MPa in each shaft, determine the largest torque T that may be applied to gear B .

SOLUTION

Gears B and C :

$$\phi_B = \frac{r_C}{r_B} \phi_C = \frac{40}{100} \phi_C \quad \phi_B = 0.4 \phi_C \quad (1)$$

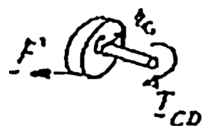

$$\Sigma M_C = 0: T_{CD} = r_C F \quad (2)$$



$$\Sigma M_B = 0: T - T_{AB} = r_B F \quad (3)$$

Solve (2) for F and substitute into (3):

$$T - T_{AB} = \frac{r_B}{r_C} T_{CD} \quad T = T_{AB} + \frac{100}{40} T_{CD} \quad (4)$$

$$T = T_{AB} + 2.5 T_{CD}$$

Shaft AB :

$$L = 0.3 \text{ m}, \quad c = 0.030 \text{ m}$$

$$\phi_B = \phi_{B/A} = \frac{T_{AB} L}{JG} = \frac{T_{AB} (0.3)}{\frac{\pi}{2} (0.030)^4 G} = 235.77 \times 10^3 \frac{T_{AB}}{G} \quad (5)$$

Shaft CD :

$$L = 0.5 \text{ m}, \quad c = 0.0225 \text{ m}$$

$$\phi_C = \phi_{C/D} = \frac{T_{CD} L}{JG} = \frac{T_{CD} (0.5)}{\frac{\pi}{2} (0.0225)^4 G} = 1242 \times 10^3 \frac{T_{CD}}{G} \quad (6)$$

PROBLEM 3.58 (Continued)

Substitute from (5) and (6) into (1) :

$$\begin{aligned}\phi_B = 0.4 \phi_C: \quad 235.79 \times 10^3 \frac{T_{AB}}{G} &= 0.4 \times 1242 \times 10^3 \frac{T_{CD}}{G} \\ T_{CD} &= 0.47462 T_{AB}\end{aligned}\quad (7)$$

Substitute for T_{CD} from (7) into (4):

$$T = T_{AB} + 2.5 (0.47462 T_{AB}) \quad T = 2.1865 T_{AB} \quad (8)$$

Solving (7) for T_{AB} and substituting into (8),

$$T = 2.1865 \left(\frac{T_{CD}}{0.47462} \right) \quad T = 4.6068 T_{CD} \quad (9)$$

Stress criterion for shaft AB :

$$\begin{aligned}\tau_{AB} = \tau_{\text{all}} &= 50 \text{ MPa:} \\ \tau_{AB} = \frac{T_{AB}c}{J} \quad T_{AB} &= \frac{J}{c} \tau_{AB} = \frac{\pi}{2} c^3 \tau_{AB} \\ &= \frac{\pi}{2} (0.030 \text{ m})^3 (50 \times 10^6 \text{ Pa}) = 2120.6 \text{ N} \cdot \text{m}\end{aligned}$$

From (8):

$$T = 2.1865(2120.6 \text{ N} \cdot \text{m}) = 4.64 \text{ kN} \cdot \text{m}$$

Stress criterion for shaft CD :

$$\begin{aligned}\tau_{CD} = \tau_{\text{all}} &= 50 \text{ MPa:} \\ \tau_{CD} = \frac{T_{CD}c}{J} \quad T_{CD} &= \frac{\pi}{2} c^3 \tau_{CD} = \frac{\pi}{2} (0.0225 \text{ m})^3 (50 \times 10^6 \text{ Pa}) \\ &= 894.62 \text{ N} \cdot \text{m}\end{aligned}$$

From (7):

$$T = 4.6068(894.62 \text{ N} \cdot \text{m}) = 4.12 \text{ kN} \cdot \text{m}$$

The smaller value for T governs.

$$T = 4.12 \text{ kN} \cdot \text{m} \quad \blacktriangleleft$$

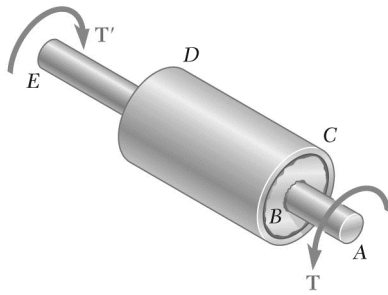

PROBLEM 3.59

The steel jacket CD has been attached to the 40-mm-diameter steel shaft AE by means of *rigid* flanges welded to the jacket and to the rod. The outer diameter of the jacket is 80 mm and its wall thickness is 4 mm. If $500 \text{ N} \cdot \text{m}$ torques are applied as shown, determine the maximum shearing stress in the jacket.

SOLUTION

Solid shaft: $c = \frac{1}{2}d = 0.020 \text{ m}$

$$J_S = \frac{\pi}{2}c^4 = \frac{\pi}{2}(0.020)^4 = 251.33 \times 10^{-9} \text{ m}^4$$

Jacket: $c_2 = \frac{1}{2}d = 0.040 \text{ m}$

$$c_1 = c_2 - t = 0.040 - 0.004 = 0.036 \text{ m}$$

$$J_J = \frac{\pi}{2}(c_2^4 - c_1^4) = \frac{\pi}{2}(0.040^4 - 0.036^4) \\ = 1.3829 \times 10^{-6} \text{ m}^4$$

Torque carried by shaft. $T_S = GJ_S \phi/L$

Torque carried by jacket. $T_J = GJ_J \phi/L$

Total torque. $T = T_S + T_J = (J_S + J_J)G\phi/L \quad \therefore \quad \frac{G\phi}{L} = \frac{T}{J_S + J_J}$

$$T_J = \frac{J_J}{J_S + J_J}T = \frac{(1.3829 \times 10^{-6})(500)}{1.3829 \times 10^{-6} + 251.33 \times 10^{-6}} = 423.1 \text{ N} \cdot \text{m}$$

Maximum shearing stress in jacket.

$$\tau = \frac{T_J c_2}{J_J} = \frac{(423.1)(0.040)}{1.3829 \times 10^{-6}} = 12.24 \times 10^6 \text{ Pa} \quad 12.24 \text{ MPa} \quad \blacktriangleleft$$

PROBLEM 3.60

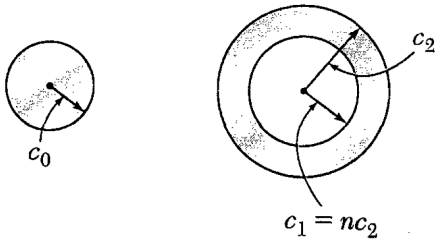

A solid shaft and a hollow shaft are made of the same material and are of the same weight and length. Denoting by n the ratio c_1/c_2 , show that the ratio T_s/T_h of the torque T_s in the solid shaft to the torque T_h in the hollow shaft is (a) $\sqrt{(1-n^2)/(1+n^2)}$ if the maximum shearing stress is the same in each shaft, (b) $(1-n)/(1+n^2)$ if the angle of twist is the same for each shaft.

SOLUTION

For equal weight and length, the areas are equal.

$$\pi c_0^2 = \pi(c_2^2 - c_1^2) = \pi c_2^2(1 - n^2) \quad \therefore \quad c_0 = c_2(1 - n^2)^{1/2}$$

$$J_s = \frac{\pi}{2} c_0^4 = \frac{\pi}{2} c_2^4 (1 - n^2)^2 \qquad J_h = \frac{\pi}{2} (c_2^4 - c_1^4) = \frac{\pi}{2} c_2^4 (1 - n^4)$$

(a) For equal stresses.

$$\tau = \frac{T_s c_0}{J_s} = \frac{T_h c_2}{J_h}$$

$$\frac{T_s}{T_h} = \frac{J_s c_2}{J_h c_0} = \frac{\frac{\pi}{2} c_2^4 (1 - n^2)^2 c_2}{\frac{\pi}{2} c_2^4 (1 - n^4) c_2 (1 - n^2)^{1/2}} = \frac{1 - n^2}{(1 + n^2)(1 - n^2)^{1/2}} = \frac{(1 - n^2)^{1/2}}{1 + n^2}$$

(b) For equal angles of twist.

$$\varphi = \frac{T_s L}{G J_s} = \frac{T_h L}{G J_h}$$

$$\frac{T_s}{T_h} = \frac{J_s}{J_h} = \frac{\frac{\pi}{2} c_2^4 (1 - n^2)^2}{\frac{\pi}{2} c_2^4 (1 - n^4)} = \frac{(1 - n^2)^2}{1 - n^4} = \frac{1 - n^2}{1 + n^2}$$

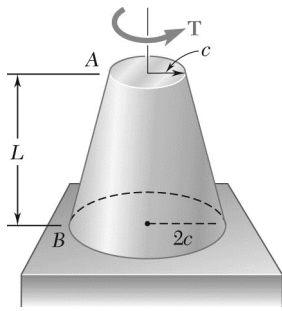

PROBLEM 3.61

A torque T is applied as shown to a solid tapered shaft AB . Show by integration that the angle of twist at A is

$$\phi = \frac{7TL}{12\pi Gc^4}$$

SOLUTION

Introduce coordinate y as shown.

$$r = \frac{cy}{L}$$

Twist in length dy :

$$\begin{aligned} d\phi &= \frac{Tdy}{GJ} = \frac{Tdy}{G\frac{\pi}{2}r^4} = \frac{2TL^4 dy}{\pi Gc^4 y^4} \\ \phi &= \int_L^{2L} \frac{2TL^4}{\pi Gc^4} \frac{dy}{y^4} = \frac{2TL}{\pi Gc^4} \int_L^{2L} \frac{dy}{y^4} \\ &= \frac{2TL^4}{\pi Gc^4} \left\{ -\frac{1}{3y^3} \right\}_L^{2L} = \frac{2TL^4}{\pi Gc^4} \left\{ -\frac{1}{24L^3} + \frac{1}{3L^3} \right\} \\ &= \frac{2TL^4}{\pi Gc^4} \left\{ \frac{7}{24L^3} \right\} = \frac{7TL}{12\pi Gc^4} \end{aligned}$$

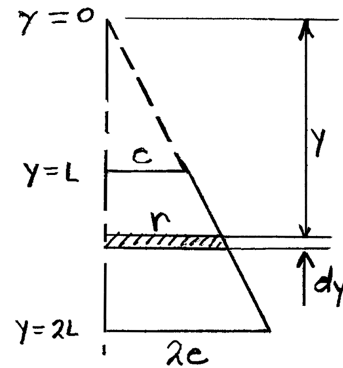

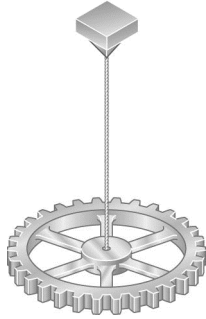

PROBLEM 3.62

The mass moment of inertia of a gear is to be determined experimentally by using a torsional pendulum consisting of a 6-ft steel wire. Knowing that $G = 11.2 \times 10^6$ psi, determine the diameter of the wire for which the torsional spring constant will be 4.27 lb · ft/rad.

SOLUTION

Torsion spring constant $K = 4.27 \text{ lb} \cdot \text{ft/rad} = 51.24 \text{ lb} \cdot \text{in/rad}$

$$K = \frac{T}{\phi} = \frac{T}{TL/GJ} = \frac{GJ}{L} = \frac{\pi Gc^4}{2L}$$

$$c^4 = \frac{2LK}{\pi G} = \frac{(2)(72)(51.24)}{\pi(11.2 \times 10^6)} = 209.7 \times 10^{-6} \text{ in}^4$$

$$c = 0.1203 \text{ in.}$$

$$d = 2c = 0.241 \text{ in.} \quad \blacktriangleleft$$

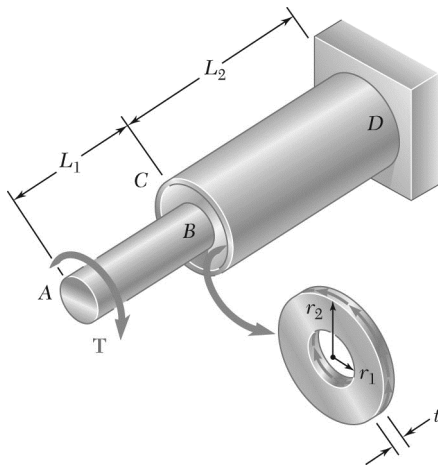

PROBLEM 3.63

An annular plate of thickness t and modulus G is used to connect shaft AB of radius r_1 to tube CD of radius r_2 . Knowing that a torque T is applied to end A of shaft AB and that end D of tube CD is fixed, (a) determine the magnitude and location of the maximum shearing stress in the annular plate, (b) show that the angle through which end B of the shaft rotates with respect to end C of the tube is

$$\phi_{BC} = \frac{T}{4\pi Gt} \left(\frac{1}{r_1^2} - \frac{1}{r_2^2} \right)$$

SOLUTION

Use a free body consisting of shaft AB and an inner portion of the plate BC , the outer radius of this portion being ρ .

The force per unit length of circumference is τt .

$$\begin{aligned} \Sigma M &= 0 \\ \tau t(2\pi\rho)\rho - T &= 0 \\ \tau &= \frac{T}{2\pi t\rho^2} \end{aligned}$$

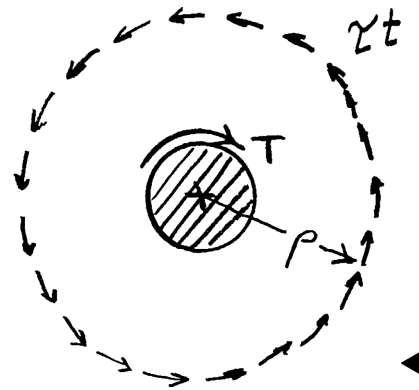

(a) Maximum shearing stress occurs at $\rho = r_1$ $\tau_{\max} = \frac{T}{2\pi t r_1^2}$

Shearing strain: $\gamma = \frac{\tau}{G} = \frac{T}{2\pi G t \rho^2}$

The relative circumferential displacement in radial length $d\rho$ is

$$\begin{aligned} d\delta &= \gamma d\rho = \rho d\phi \\ d\phi &= \gamma \frac{d\rho}{\rho} \\ d\phi &= \frac{T}{2\pi G t \rho^2} \frac{d\rho}{\rho} = \frac{T}{2\pi G t \rho^3} d\rho \end{aligned}$$

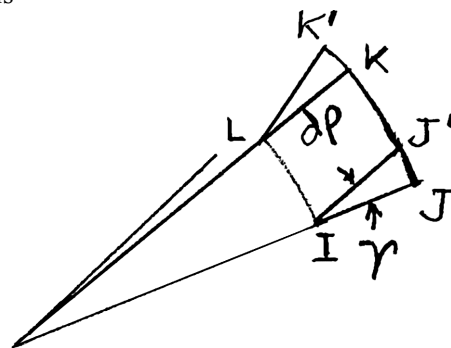

(b)
$$\begin{aligned} \phi_{B/C} &= \int_{r_1}^{r_2} \frac{T}{2\pi G t \rho^3} d\rho = \frac{T}{2\pi G t} \int_{r_1}^{r_2} \frac{d\rho}{\rho^3} = \frac{T}{2\pi G t} \left[-\frac{1}{2\rho^2} \right]_{r_1}^{r_2} \\ &= \frac{T}{2\pi G t} \left[-\frac{1}{2r_2^2} + \frac{1}{2r_1^2} \right] = \frac{T}{4\pi G t} \left[\frac{1}{r_1^2} - \frac{1}{r_2^2} \right] \end{aligned}$$

PROBLEM 3.64

Determine the maximum shearing stress in a solid shaft of 12-mm diameter as it transmits 2.5 kW at a frequency of (a) 25 Hz, (b) 50 Hz.

SOLUTION

$$c = \frac{1}{2}d = 6 \text{ mm} = 0.006 \text{ m} \quad P = 2.5 \text{ kW} = 2500 \text{ W}$$

$$(a) \quad \underline{f = 25 \text{ Hz}} \quad T = \frac{P}{2\pi f} = \frac{2500}{2\pi(25)} = 15.9155 \text{ N} \cdot \text{m}$$

$$\tau = \frac{Tc}{J} = \frac{2T}{\pi c^3} = \frac{2(15.9155)}{\pi(0.006)^3} = 46.9 \times 10^6 \text{ Pa} \quad \tau = 46.9 \text{ MPa} \quad \blacktriangleleft$$

$$(b) \quad \underline{f = 50 \text{ Hz}} \quad T = \frac{2500}{2\pi(50)} = 7.9577 \text{ N} \cdot \text{m}$$

$$\tau = \frac{2(7.9577)}{\pi(0.006)^3} = 23.5 \times 10^6 \text{ Pa} \quad \tau = 23.5 \text{ MPa} \quad \blacktriangleleft$$

PROBLEM 3.65

Determine the maximum shearing stress in a solid shaft of 1.5-in. diameter as it transmits 75 hp at a speed of (a) 750 rpm, (b) 1500 rpm.

SOLUTION

$$c = \frac{1}{2}d = 0.75 \text{ in.} \quad P = 75 \text{ hp} = (75)(6600) = 495 \times 10^3 \text{ lb} \cdot \text{in/s}$$

$$(a) \quad f = \frac{750}{60} = 12.5 \text{ Hz}$$

$$T = \frac{P}{2\pi f} = \frac{495 \times 10^3}{2\pi(12.5)} = 6.3025 \times 10^3 \text{ lb} \cdot \text{in}$$

$$\tau = \frac{Tc}{J} = \frac{2T}{\pi c^3} = \frac{(2)(6.3025 \times 10^3)}{\pi(0.75)^3} = 9.51 \times 10^3 \text{ psi} \quad \tau = 9.51 \text{ ksi} \blacktriangleleft$$

$$(b) \quad f = \frac{1500}{60} = 25 \text{ Hz}$$

$$T = \frac{495 \times 10^3}{2\pi(25)} = 3.1513 \times 10^3 \text{ lb} \cdot \text{in}$$

$$\tau = \frac{(2)(3.1513 \times 10^3)}{\pi(0.75)^3} = 4.76 \times 10^3 \text{ psi} \quad \tau = 4.76 \text{ ksi} \blacktriangleleft$$

PROBLEM 3.66

Design a solid steel shaft to transmit 0.375 kW at a frequency of 29 Hz, if the shearing stress in the shaft is not to exceed 35 MPa.

SOLUTION

$$\tau_{\text{all}} = 35 \times 10^6 \text{ Pa} \quad P = 0.375 \times 10^3 \text{ W} \quad f = 29 \text{ Hz}$$

$$T = \frac{P}{2\pi f} = \frac{0.375 \times 10^3}{2\pi(29)} = 2.0580 \text{ N} \cdot \text{m}$$

$$\tau = \frac{Tc}{J} = \frac{2T}{\pi c^3} \quad \therefore \quad c^3 = \frac{2T}{\pi\tau} = \frac{(2)(2.0580)}{\pi(35 \times 10^6)} = 37.43 \times 10^{-9} \text{ m}^3$$

$$c = 3.345 \times 10^{-3} \text{ m} = 3.345 \text{ mm}$$

$$d = 2c$$

$$d = 6.69 \text{ mm} \quad \blacktriangleleft$$

PROBLEM 3.67

Design a solid steel shaft to transmit 100 hp at a speed of 1200 rpm, if the maximum shearing stress is not to exceed 7500 psi.

SOLUTION

$$\tau_{\text{all}} = 7500 \text{ psi} \quad P = 100 \text{ hp} = 660 \times 10^3 \text{ lb} \cdot \text{in/s}$$

$$f = \frac{1200}{60} = 20 \text{ Hz} \quad T = \frac{P}{2\pi f} = \frac{660 \times 10^3}{2\pi(20)} = 5.2521 \times 10^3 \text{ lb} \cdot \text{in}$$

$$\tau = \frac{Tc}{J} = \frac{2T}{\pi c^3} \quad \therefore c^3 = \frac{2T}{\pi\tau} = \frac{(2)(5.2521 \times 10^3)}{\pi(7500)} = 0.4458 \text{ in}^3$$

$$c = 0.7639 \text{ in.}$$

$$d = 2c$$

$$d = 1.528 \text{ in.} \quad \blacktriangleleft$$

PROBLEM 3.68

Determine the required thickness of the 50-mm tubular shaft of Example 3.07 if it is to transmit the same power while rotating at a frequency of 30 Hz.

SOLUTION

From Example 3.07, $P = 100 \text{ kW} = 100 \times 10^3 \text{ W}$

$$\tau_{\text{all}} = 60 \text{ MPa} = 60 \times 10^6 \text{ Pa} \quad c_2 = \frac{1}{2}d = 25 \text{ mm} = 0.025 \text{ m}$$

$$f = 30 \text{ Hz}$$

$$T = \frac{P}{2\pi f} = 530.52 \text{ N} \cdot \text{m}$$

$$J = \frac{\pi}{2}(c_2^4 - c_1^4) \quad \tau = \frac{Tc_2}{J} = \frac{2Tc_2}{\pi(c_2^4 - c_1^4)}$$

$$c_1^4 = c_2^4 - \frac{2Tc_2}{\pi\tau} = 0.025^4 - \frac{(2)(530.52)(0.025)}{\pi(60 \times 10^6)} = 249.90 \times 10^{-9} \text{ m}^4$$

$$c_1 = 22.358 \times 10^{-3} \text{ m} = 22.358 \text{ mm}$$

$$t = c_2 - c_1 = 25 \text{ mm} - 22.358 \text{ mm} = 2.642 \text{ mm}$$

$$t = 2.64 \text{ mm} \quad \blacktriangleleft$$

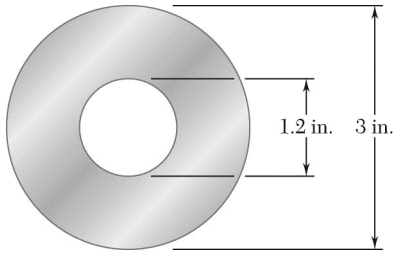

PROBLEM 3.69

While a steel shaft of the cross section shown rotates at 120 rpm, a stroboscopic measurement indicates that the angle of twist is 2° in a 12-ft length. Using $G = 11.2 \times 10^6$ psi, determine the power being transmitted.

SOLUTION

$$\phi = 2^\circ = 34.907 \times 10^{-3} \text{ rad} \quad L = 12 \text{ ft} = 144 \text{ in.}$$

$$c_2 = \frac{1}{2}d_o = 1.5 \text{ in.} \quad c_1 = \frac{1}{2}d_i = 0.6 \text{ in.}$$

$$J = \frac{\pi}{2}(c_2^4 - c_1^4) = \frac{\pi}{2}(1.5^4 - 0.6^4) = 7.7486 \text{ in}^4$$

$$f = \frac{120}{60} = 2 \text{ Hz}$$

$$T = \frac{GJ\phi}{L} = \frac{(11.2 \times 10^6)(7.7486)(34.907 \times 10^{-3})}{144} = 21.037 \times 10^3 \text{ lb} \cdot \text{in}$$

$$P = 2\pi fT = 2\pi(2)(21.037 \times 10^3) = 264.36 \times 10^3 \text{ lb} \cdot \text{in/s}$$

Since 1 hp = 66000 lb · in/s,

$$P = 40.1 \text{ hp} \blacktriangleleft$$

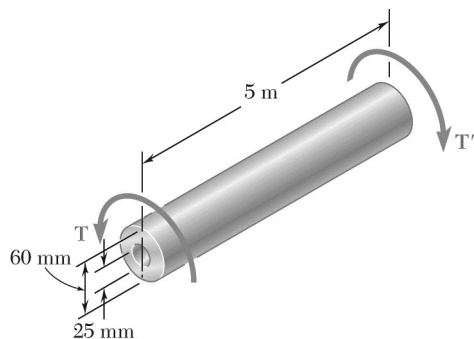

PROBLEM 3.70

The hollow steel shaft shown ($G = 77.2 \text{ GPa}$, $\tau_{\text{all}} = 50 \text{ MPa}$) rotates at 240 rpm. Determine (a) the maximum power that can be transmitted, (b) the corresponding angle of twist of the shaft.

SOLUTION

$$c_2 = \frac{1}{2}d_2 = 30 \text{ mm}$$

$$c_1 = \frac{1}{2}d_1 = 12.5 \text{ mm}$$

$$J = \frac{\pi}{2}(c_2^4 - c_1^4) = \frac{\pi}{2}[(30)^4 - (12.5)^4]$$

$$= 1.234 \times 10^6 \text{ mm}^4 = 1.234 \times 10^{-6} \text{ m}^4$$

$$\tau_m = 50 \times 10^6 \text{ Pa}$$

$$\tau_m = \frac{Tc}{J} \quad T = \frac{\tau_m J}{c} = \frac{(50 \times 10^6)(1.234 \times 10^{-6})}{30 \times 10^{-3}} = 2056.7 \text{ N} \cdot \text{m}$$

Angular speed. $f = 240 \text{ rpm} = 4 \text{ rev/sec} = 4 \text{ Hz}$

(a) Power being transmitted. $P = 2\pi f T = 2\pi(4)(2056.7) = 51.7 \times 10^3 \text{ W}$

$P = 51.7 \text{ kW} \blacktriangleleft$

(b) Angle of twist. $\varphi = \frac{TL}{GJ} = \frac{(2056.7)(5)}{(77.2 \times 10^9)(1.234 \times 10^{-6})} = 0.1078 \text{ rad}$

$\varphi = 6.17^\circ \blacktriangleleft$

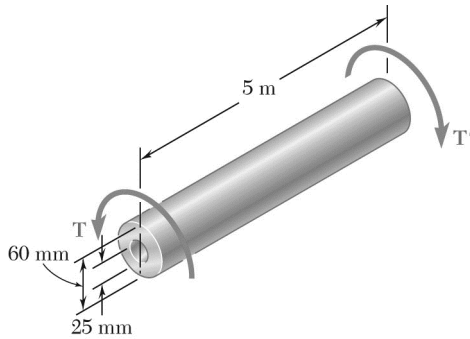

PROBLEM 3.71

As the hollow steel shaft shown rotates at 180 rpm, a stroboscopic measurement indicates that the angle of twist of the shaft is 3° . Knowing that $G = 77.2$ GPa, determine (a) the power being transmitted, (b) the maximum shearing stress in the shaft.

SOLUTION

$$c_2 = \frac{1}{2}d_2 = 30 \text{ mm}$$

$$c_1 = \frac{1}{2}d_1 = 12.5 \text{ mm}$$

$$J = \frac{\pi}{2}(c_2^4 - c_1^4) = \frac{\pi}{2}[(30)^4 - (12.5)^4]$$

$$= 1.234 \times 10^6 \text{ mm}^4 = 1.234 \times 10^{-6} \text{ m}^4$$

$$\phi = 3^\circ = 0.05236 \text{ rad}$$

$$\phi = \frac{TL}{GJ}$$

$$T = \frac{GJ\phi}{L} = \frac{(77.2 \times 10^9)(1.234 \times 10^{-6})(0.0536)}{5} = 997.61 \text{ N} \cdot \text{m}$$

Angular speed: $f = 180 \text{ rpm} = 3 \text{ rev/sec} = 3 \text{ Hz}$

(a) Power being transmitted. $P = 2\pi fT = 2\pi(3)(997.61) = 18.80 \times 10^3 \text{ W}$

$$P = 18.80 \text{ kW} \blacktriangleleft$$

(b) Maximum shearing stress. $\tau_m = \frac{Tc_2}{J} = \frac{(997.61)(30 \times 10^{-3})}{1.234 \times 10^{-6}}$

$$= 24.3 \times 10^6 \text{ Pa}$$

$$\tau_m = 24.3 \text{ MPa} \blacktriangleleft$$

PROBLEM 3.72

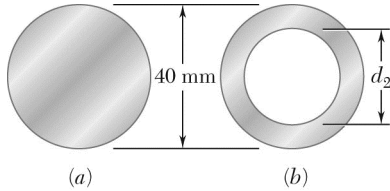

The design of a machine element calls for a 40-mm-outer-diameter shaft to transmit 45 kW. (a) If the speed of rotation is 720 rpm, determine the maximum shearing stress in shaft *a*. (b) If the speed of rotation can be increased 50% to 1080 rpm, determine the largest inner diameter of shaft *b* for which the maximum shearing stress will be the same in each shaft.

SOLUTION

$$(a) \quad f = \frac{720}{60} = 12 \text{ Hz}$$

$$P = 45 \text{ kW} = 45 \times 10^3 \text{ W}$$

$$T = \frac{P}{2\pi f} = \frac{45 \times 10^3}{2\pi(12)} = 596.83 \text{ N} \cdot \text{m}$$

$$c = \frac{1}{2}d = 20 \text{ mm} = 0.020 \text{ m}$$

$$\tau = \frac{Tc}{J} = \frac{2T}{\pi c^3} = \frac{(2)(596.83)}{\pi(0.020)^3} = 47.494 \times 10^6 \text{ Pa}$$

$$\tau_{\max} = 47.5 \text{ MPa} \quad \blacktriangleleft$$

$$(b) \quad f = \frac{1080}{60} = 18 \text{ Hz}$$

$$T = \frac{45 \times 10^3}{2\pi(18)} = 397.89 \text{ N} \cdot \text{m}$$

$$\tau = \frac{Tc_2}{J} = \frac{2Tc_2}{\pi(c_2^4 - c_1^4)}$$

$$c_1^4 = c_2^4 - \frac{2Tc_2}{\pi\tau}$$

$$c_1^4 = 0.020^4 - \frac{(2)(397.89)(0.020)}{\pi(47.494 \times 10^6)} = 53.333 \times 10^{-9}$$

$$c_1 = 15.20 \times 10^{-3} \text{ m} = 15.20 \text{ mm}$$

$$d_2 = 2c_1 = 30.4 \text{ mm} \quad \blacktriangleleft$$

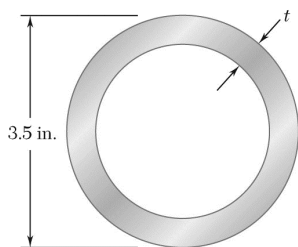

PROBLEM 3.73

A steel pipe of 3.5-in. outer diameter is to be used to transmit a torque of 3000 lb · ft without exceeding an allowable shearing stress of 8 ksi. A series of 3.5-in.-outer-diameter pipes is available for use. Knowing that the wall thickness of the available pipes varies from 0.25 in. to 0.50 in. in 0.0625-in. increments, choose the lightest pipe that can be used.

SOLUTION

$$T = 3000 \text{ lb} \cdot \text{ft} = 36 \times 10^3 \text{ lb} \cdot \text{in}$$

$$c_2 = \frac{1}{2} d_o = 1.75 \text{ in.}$$

$$\tau = \frac{Tc_2}{J} = \frac{2Tc_2}{\pi(c_2^4 - c_1^4)}$$

$$c_1^4 = c_2^4 - \frac{2Tc_2}{\pi\tau} = 1.75^4 - \frac{(2)(36 \times 10^3)(1.75)}{\pi(8 \times 10^3)} = 4.3655 \text{ in}^4$$

$$c_1 = 1.4455 \text{ in.}$$

Required minimum thickness: $t = c_2 - c_1$

$$t = 1.75 - 1.4455 = 0.3045 \text{ in.}$$

Available thicknesses: 0.25 in., 0.3125 in., 0.375 in., etc.

Use

$$t = 0.3125 \text{ in.} \quad \blacktriangleleft$$

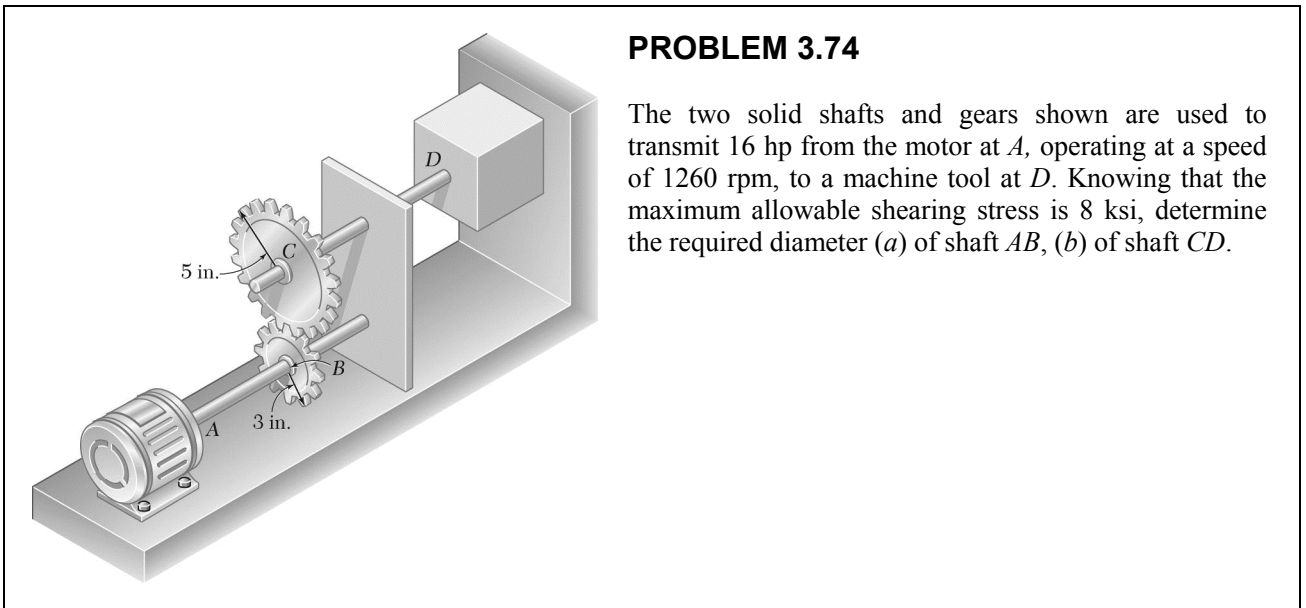

PROBLEM 3.74

The two solid shafts and gears shown are used to transmit 16 hp from the motor at *A*, operating at a speed of 1260 rpm, to a machine tool at *D*. Knowing that the maximum allowable shearing stress is 8 ksi, determine the required diameter (a) of shaft *AB*, (b) of shaft *CD*.

SOLUTION

(a) Shaft *AB*:

$$P = 16 \text{ hp} = (16)(6600) = 105.6 \times 10^3 \text{ lb} \cdot \text{in}/\text{sec}$$

$$f = \frac{1260}{60} = 21 \text{ Hz}$$

$$\tau = 8 \text{ ksi} = 8 \times 10^3 \text{ psi}$$

$$T_{AB} = \frac{P}{2\pi f} = \frac{105.6 \times 10^3}{2\pi(21)} = 800.32 \text{ lb} \cdot \text{in}$$

$$\tau = \frac{Tc}{J} = \frac{2T}{\pi c^3} \quad c = \sqrt[3]{\frac{2T}{\pi\tau}}$$

$$c = \sqrt[3]{\frac{(2)(800.32)}{\pi(8 \times 10^3)}} = 0.399 \text{ in.}$$

$$d_{AB} = 2c = 0.799 \text{ in.}$$

$$d_{AB} = 0.799 \text{ in.} \quad \blacktriangleleft$$

(b) Shaft *CD*:

$$T_{CD} = \frac{r_C}{r_B} T_{AB} = \frac{5}{3}(800.32) = 1.33387 \times 10^3 \text{ lb} \cdot \text{in}$$

$$c = \sqrt[3]{\frac{2T}{\pi\tau}} = \sqrt[3]{\frac{(2)(1.33387 \times 10^3)}{\pi(8 \times 10^3)}} = 0.473 \text{ in.}$$

$$d_{CD} = 2c = 0.947 \text{ in.}$$

$$d_{CD} = 0.947 \text{ in.} \quad \blacktriangleleft$$

PROBLEM 3.75

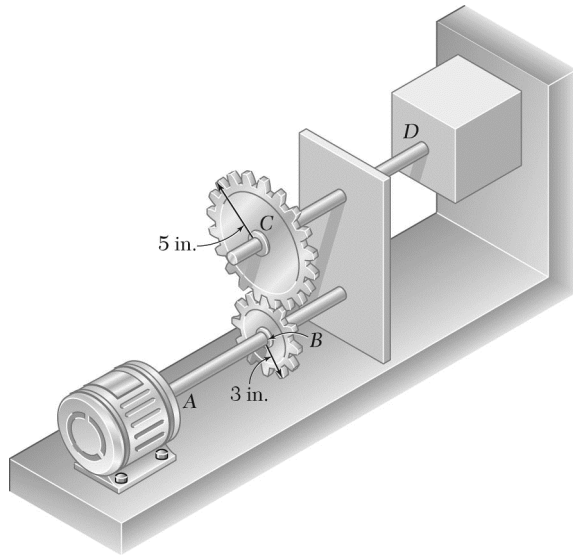

The two solid shafts and gears shown are used to transmit 16 hp from the motor at A operating at a speed of 1260 rpm to a machine tool at D . Knowing that each shaft has a diameter of 1 in., determine the maximum shearing stress (a) in shaft AB , (b) in shaft CD .

SOLUTION

(a) Shaft AB : $P = 16 \text{ hp} = (16)(6600) = 105.6 \times 10^3 \text{ lb} \cdot \text{in}/\text{sec}$

$$f = \frac{1260}{60} = 21 \text{ Hz}$$

$$T_{AB} = \frac{P}{2\pi f} = \frac{105.6 \times 10^3}{2\pi(21)} = 800.32 \text{ lb} \cdot \text{in}$$

$$c = \frac{1}{2}d = 0.5 \text{ in.}$$

$$\tau = \frac{Tc}{J} = \frac{2T}{\pi c^3}$$

$$= \frac{(2)(800.32)}{\pi(0.5)^3} = 4.08 \times 10^3 \text{ psi} \quad \tau_{AB} = 4.08 \text{ ksi} \quad \blacktriangleleft$$

(b) Shaft CD : $T_{CD} = \frac{r_C}{r_B} T_{AB} = \frac{5}{3}(800.32) = 1.33387 \times 10^3 \text{ lb} \cdot \text{in}$

$$\tau = \frac{2T}{\pi c^3} = \frac{(2)(1.33387 \times 10^3)}{\pi(0.5)^3} = 6.79 \times 10^3 \text{ psi} \quad \tau_{CD} = 6.79 \text{ ksi} \quad \blacktriangleleft$$

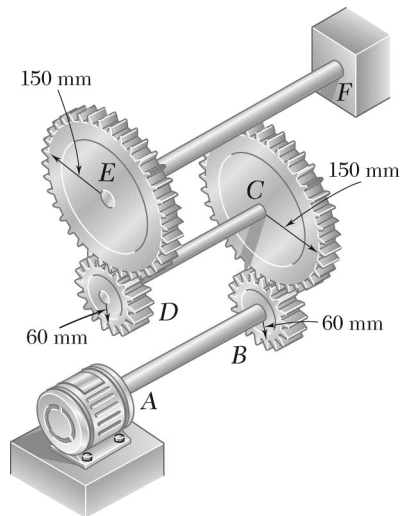

PROBLEM 3.76

Three shafts and four gears are used to form a gear train that will transmit 7.5 kW from the motor at A to a machine tool at F . (Bearings for the shafts are omitted in the sketch.) Knowing that the frequency of the motor is 30 Hz and that the allowable stress for each shaft is 60 MPa, determine the required diameter of each shaft.

SOLUTION

$$P = 7.5 \text{ kW} = 7.5 \times 10^3 \text{ W} \quad \tau_{\text{all}} = 60 \text{ MPa} = 60 \times 10^6 \text{ Pa}$$

Shaft AB:

$$f_{AB} = 30 \text{ Hz} \quad T_{AB} = \frac{P}{2\pi f_{AB}} = \frac{7.5 \times 10^3}{2\pi(30)} = 39.789 \text{ N} \cdot \text{m}$$

$$\tau = \frac{Tc_{AB}}{J_{AB}} = \frac{2T}{\pi c_{AB}^3} \quad \therefore c_{AB}^3 = \frac{2T}{\pi\tau}$$

$$c_{AB}^3 = \frac{(2)(39.789)}{\pi(60 \times 10^6)} = 422.17 \times 10^{-9} \text{ m}^3$$

$$c_{AB} = 7.50 \times 10^{-3} \text{ m} = 7.50 \text{ mm}$$

$$d_{AB} = 2c_{AB} = 15.00 \text{ mm} \quad \blacktriangleleft$$

Shaft CD:

$$f_{CD} = \frac{r_B}{r_C} f_{AB} = \frac{60}{150} (30) = 12 \text{ Hz} \quad T_{CD} = \frac{P}{2\pi f_{CD}} = \frac{7.5 \times 10^3}{2\pi(12)} = 99.472 \text{ N} \cdot \text{m}$$

$$\tau_{CD} = \frac{Tc_{CD}}{J_{CD}} = \frac{2T}{\pi c_{CD}^3} \quad \therefore c_{CD}^3 = \frac{2T_{CD}}{\pi\tau} = \frac{2(99.472)}{\pi(60 \times 10^6)} = 1.05543 \times 10^{-6} \text{ m}^3$$

$$c_{CD} = 10.18 \times 10^{-3} \text{ m} = 10.18 \text{ mm}$$

$$d_{CD} = 2c_{CD} = 20.4 \text{ mm} \quad \blacktriangleleft$$

Shaft EF:

$$f_{EF} = \frac{r_D}{r_E} f_{CD} = \frac{60}{150} (12) = 4.8 \text{ Hz} \quad T_{EF} = \frac{P}{2\pi f_{EF}} = \frac{7.5 \times 10^3}{2\pi(4.8)} = 248.68 \text{ N} \cdot \text{m}$$

$$\tau = \frac{Tc_{EF}}{J_{EF}} = \frac{2T}{\pi c_{EF}^3} \quad \therefore c_{EF}^3 = \frac{(2)(248.68)}{\pi(60 \times 10^6)} = 2.6886 \times 10^{-6} \text{ m}^3$$

$$c_{EF} = 13.82 \times 10^{-3} \text{ m} = 13.82 \text{ mm}$$

$$d_{EF} = 2c_{EF} = 27.6 \text{ mm} \quad \blacktriangleleft$$

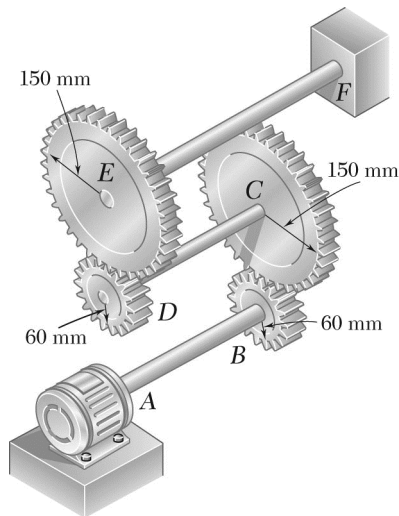

PROBLEM 3.77

Three shafts and four gears are used to form a gear train that will transmit power from the motor at A to a machine tool at F . (Bearings for the shafts are omitted in the sketch.) The diameter of each shaft is as follows: $d_{AB}=16$ mm, $d_{CD}=20$ mm, $d_{EF}=28$ mm. Knowing that the frequency of the motor is 24 Hz and that the allowable shearing stress for each shaft is 75 MPa, determine the maximum power that can be transmitted.

SOLUTION

$$\tau_{\text{all}} = 75 \text{ MPa} = 75 \times 10^6 \text{ Pa}$$

Shaft AB: $c_{AB} = \frac{1}{2}d_{AB} = 0.008 \text{ m}$ $\tau = \frac{Tc_{AB}}{J_{AB}} = \frac{2T}{\pi c_{AB}^3}$

$$T_{\text{all}} = \frac{\pi}{2}c_{AB}^3 \tau_{\text{all}} = \frac{\pi}{2}(0.008)^3 (75 \times 10^6) = 60.319 \text{ N}\cdot\text{m}$$

$$f_{AB} = 24 \text{ Hz} \quad P_{\text{all}} = 2\pi f_{AB} T_{\text{all}} = 2\pi(24)(60.319) = 9.10 \times 10^3 \text{ W}$$

Shaft CD: $c_{CD} = \frac{1}{2}d_{CD} = 0.010 \text{ m}$

$$\tau = \frac{Tc_{CD}}{J_{CD}} = \frac{2T}{\pi c_{CD}^3} \quad \therefore T_{\text{all}} = \frac{\pi}{2}c_{CD}^3 \tau_{\text{all}} = \frac{\pi}{2}(0.010)^3 (75 \times 10^6) = 117.81 \text{ N}\cdot\text{m}$$

$$f_{CD} = \frac{r_B}{r_C} f_{AB} = \frac{60}{150} (24) = 9.6 \text{ Hz} \quad P_{\text{all}} = 2\pi f_{CD} T_{\text{all}} = 2\pi(9.6)(117.81) = 7.11 \times 10^3 \text{ W}$$

Shaft EF: $c_{EF} = \frac{1}{2}d_{EF} = 0.014 \text{ m}$

$$T_{\text{all}} = \frac{\pi}{2}c_{EF}^3 \tau_{\text{all}} = \frac{\pi}{2}(0.014)^3 (75 \times 10^6) = 323.27 \text{ N}\cdot\text{m}$$

$$f_{EF} = \frac{r_D}{r_E} f_{CD} = \frac{60}{150} (9.6) = 3.84 \text{ Hz}$$

$$P_{\text{all}} = 2\pi f_{EF} T_{\text{all}} = 2\pi(3.84)(323.27) = 7.80 \times 10^3 \text{ W}$$

Maximum allowable power is the smallest value.

$$P_{\text{all}} = 7.11 \times 10^3 \text{ W} = 7.11 \text{ kW} \quad \blacktriangleleft$$

PROBLEM 3.78

A 1.5-m-long solid steel of 48 mm diameter is to transmit 36 kW between a motor and a machine tool. Determine the lowest speed at which the shaft can rotate, knowing that $G = 77.2$ GPa, that the maximum shearing stress must not exceed 60 MPa, and the angle of twist must not exceed 2.5° .

SOLUTION

$$P = 36 \times 10^3 \text{ W}, \quad c = \frac{1}{2}d = 0.024 \text{ m}, \quad L = 1.5 \text{ m}, \quad G = 77.2 \times 10^9 \text{ Pa}$$

Torque based on maximum stress: $\tau = 60 \text{ MPa} = 60 \times 10^6 \text{ Pa}$

$$\tau = \frac{Tc}{J} \quad T = \frac{J\tau}{c} = \frac{\pi}{2}c^3 \tau = \frac{\pi}{2}(0.024)^3 (60 \times 10^6) = 1.30288 \times 10^3 \text{ N} \cdot \text{m}$$

Torque based on twist angle: $\phi = 2.5^\circ = 43.633 \times 10^{-3} \text{ rad}$

$$\phi = \frac{TL}{GJ} \quad T = \frac{GJ\phi}{L} = \frac{\pi c^4 G \phi}{2L} = \frac{\pi (0.024)^4 (77 \times 10^9) (43.633 \times 10^{-3})}{(2)(1.5)}$$
$$= 1.17033 \times 10^3 \text{ N} \cdot \text{m}$$

Smaller torque governs, so $T = 1.17033 \times 10^3 \text{ N} \cdot \text{m}$

$$P = 2\pi fT \quad f = \frac{P}{2\pi T} = \frac{36 \times 10^3}{2\pi (1.17033 \times 10^3)}$$

$$f = 4.90 \text{ Hz} \quad \blacktriangleleft$$

PROBLEM 3.79

A 2.5-m-long steel shaft of 30-mm diameter rotates at a frequency of 30 Hz. Determine the maximum power that the shaft can transmit, knowing that $G = 77.2$ GPa, that the allowable shearing stress is 50 MPa, and that the angle of twist must not exceed 7.5° .

SOLUTION

$$c = \frac{1}{2}d = 15 \text{ mm} = 0.015 \text{ m} \quad L = 2.5 \text{ m}$$

Stress requirement.

$$\tau = 50 \times 10^6 \text{ Pa} \quad \tau = \frac{Tc}{J}$$

$$T = \frac{\tau J}{c} = \frac{\pi}{2} \tau c^3 = \frac{\pi}{2} (50 \times 10^6)(0.015)^3 = 265.07 \text{ N} \cdot \text{m}$$

Twist angle requirement.

$$\phi = 7.5^\circ = 130.90 \times 10^{-3} \text{ rad} \quad G = 77.2 \times 10^9 \text{ Pa}$$

$$\phi = \frac{TL}{GJ} = \frac{2TL}{\pi Gc^4}$$

$$T = \frac{\pi}{2} Gc^4 \phi = \frac{\pi}{2} (77.2 \times 10^9)(0.015)^4 (130.90 \times 10^{-3}) = 803.60 \text{ N} \cdot \text{m}$$

Smaller value of T is the maximum allowable torque.

$$T = 265.07 \text{ N} \cdot \text{m}$$

Power transmitted at $f = 30$ Hz.

$$P = 2\pi f T = 2\pi(30)(265.07) = 49.96 \times 10^3 \text{ W}$$

$$P = 50.0 \text{ kW} \quad \blacktriangleleft$$

PROBLEM 3.80

A steel shaft must transmit 210 hp at a speed of 360 rpm. Knowing that $G = 11.2 \times 10^6$ psi, design a solid shaft so that the maximum shearing stress will not exceed 12 ksi, and the angle of twist in a 8.2-ft length must not exceed 3° .

SOLUTION

Power: $P = (210 \text{ hp})(6600 \text{ in} \cdot \text{lb/s/hp}) = 1.336 \times 10^6 \text{ in} \cdot \text{lb/s}$

Angular speed: $f = (360 \text{ rpm}) \frac{1 \text{ min.}}{60 \text{ sec}} = 6 \text{ Hz}$

Torque: $T = \frac{P}{2\pi f} = \frac{1.336 \times 10^6}{(2\pi)(6)} = 36.765 \times 10^3 \text{ lb} \cdot \text{in}$

Stress requirement: $\tau = 12 \text{ ksi}, \quad \tau = \frac{Tc}{J} = \frac{2T}{\pi c^3}$

$$c = \sqrt[3]{\frac{2T}{\pi\tau}} = \sqrt[3]{\frac{(2)(36.765 \times 10^3)}{\pi(12 \times 10^3)}} = 1.2494 \text{ in.}$$

Angle of twist requirement: $\phi = 3^\circ = 52.36 \times 10^{-3} \text{ rad}$

$$L = 8.2 \text{ ft} = 98.4 \text{ in.}$$

$$\phi = \frac{TL}{GJ} = \frac{2TL}{\pi Gc^4}$$

$$c = \sqrt[4]{\frac{2TL}{\pi G\phi}} = \sqrt[4]{\frac{(2)(36.765 \times 10^3)(98.4)}{\pi(11.2 \times 10^6)(52.36 \times 10^{-3})}} = 1.4077 \text{ in.}$$

The larger value is the required radius. $c = 1.408 \text{ in.}$

$$d = 2c$$

$$d = 2.82 \text{ in.} \quad \blacktriangleleft$$

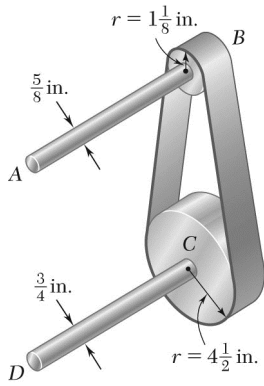

PROBLEM 3.81

The shaft-disk-belt arrangement shown is used to transmit 3 hp from point *A* to point *D*. (a) Using an allowable shearing stress of 9500 psi, determine the required speed of shaft *AB*. (b) Solve part *a*, assuming that the diameters of shafts *AB* and *CD* are, respectively, 0.75 in. and 0.625 in.

SOLUTION

$$\tau = 9500 \text{ psi} \quad P = 3 \text{ hp} = (3)(6600) = 19800 \text{ lb} \cdot \text{in/s}$$

$$\tau = \frac{Tc}{J} = \frac{2T}{\pi c^3} \quad T = \frac{\pi}{2} c^3 \tau$$

Allowable torques.

$$\frac{5}{8} \text{-in. diameter shaft:} \quad c = \frac{5}{16} \text{ in.}, \quad T_{\text{all}} = \frac{\pi}{2} \left(\frac{5}{16} \right)^3 (9500) = 455.4 \text{ lb} \cdot \text{in}$$

$$\frac{3}{4} \text{-in. diameter shaft:} \quad c = \frac{3}{8} \text{ in.}, \quad T_{\text{all}} = \frac{\pi}{2} \left(\frac{3}{8} \right)^3 (9500) = 786.9 \text{ lb} \cdot \text{in}$$

Statics:

$$T_B = r_B(F_1 - F_2) \quad T_C = r_C(F_1 - F_2)$$

$$T_B = \frac{r_B}{r_C} T_C = \frac{1.125}{4.5} T_C = 0.25 T_C$$

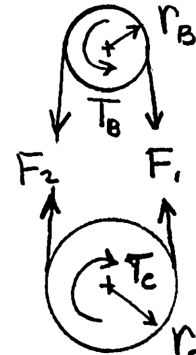

(a) Allowable torques. $T_{B,\text{all}} = 455.4 \text{ lb} \cdot \text{in} \quad T_{C,\text{all}} = 786.9 \text{ lb} \cdot \text{in}$

Assume $T_C = 786.9 \text{ lb} \cdot \text{in}$

Then $T_B = (0.25)(786.9) = 196.73 \text{ lb} \cdot \text{in} < 455.4 \text{ lb} \cdot \text{in}$ (okay)

$$P = 2\pi fT \quad f_{AB} = \frac{P}{2\pi T_B} = \frac{19800}{2\pi(196.73)}$$

$$f_{AB} = 16.02 \text{ Hz} \quad \blacktriangleleft$$

(b) Allowable torques. $T_{B,\text{all}} = 786.9 \text{ lb} \cdot \text{in} \quad T_{C,\text{all}} = 455.4 \text{ lb} \cdot \text{in}$

Assume $T_C = 455.4 \text{ lb} \cdot \text{in}$

Then $T_B = (0.25)(455.4) = 113.85 \text{ lb} \cdot \text{in} < 786.9 \text{ lb} \cdot \text{in}$

$$P = 2\pi fT \quad f_{AB} = \frac{P}{2\pi T_B} = \frac{19800}{2\pi(113.85)}$$

$$f_{AB} = 27.2 \text{ Hz} \quad \blacktriangleleft$$

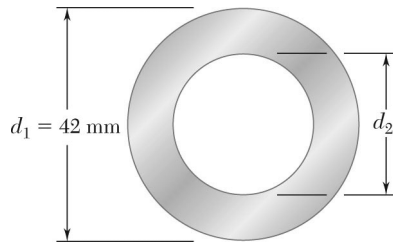

PROBLEM 3.82

A 1.6-m-long tubular steel shaft of 42-mm outer diameter d_1 is to be made of a steel for which $\tau_{\text{all}} = 75 \text{ MPa}$ and $G = 77.2 \text{ GPa}$. Knowing that the angle of twist must not exceed 4° when the shaft is subjected to a torque of $900 \text{ N} \cdot \text{m}$, determine the largest inner diameter d_2 that can be specified in the design.

SOLUTION

$$c_1 = \frac{1}{2}d_1 = 0.021 \text{ m} \quad L = 1.6 \text{ m}$$

Based on stress limit: $\tau = 75 \text{ MPa} = 75 \times 10^6 \text{ Pa}$

$$\tau = \frac{Tc_1}{J} \quad \therefore \quad J = \frac{Tc_1}{\tau} = \frac{(900)(0.021)}{75 \times 10^6} = 252 \times 10^{-9} \text{ m}^4$$

Based on angle of twist limit: $\phi = 4^\circ = 69.813 \times 10^{-3} \text{ rad}$

$$\phi = \frac{TL}{GJ} \quad \therefore \quad J = \frac{TL}{G\phi} = \frac{(900)(1.6)}{(77 \times 10^9)(69.813 \times 10^{-3})} = 267.88 \times 10^{-9} \text{ m}^4$$

Larger value for J governs. $J = 267.88 \times 10^{-9} \text{ m}^4$

$$J = \frac{\pi}{2}(c_1^4 - c_2^4)$$

$$c_2^4 = c_1^4 - \frac{2J}{\pi} = 0.021^4 - \frac{(2)(267.88 \times 10^{-9})}{\pi} = 23.943 \times 10^{-9} \text{ m}^4$$

$$c_2 = 12.44 \times 10^{-3} \text{ m} = 12.44 \text{ mm}$$

$$d_2 = 2c_2 = 24.9 \text{ mm} \quad \blacktriangleleft$$

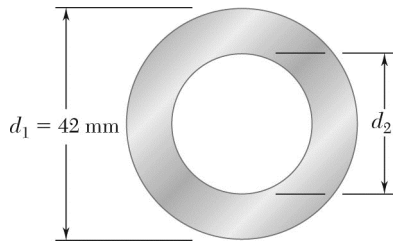

PROBLEM 3.83

A 1.6-m-long tubular steel shaft ($G = 77.2 \text{ GPa}$) of 42-mm outer diameter d_1 and 30-mm inner diameter d_2 is to transmit 120 kW between a turbine and a generator. Knowing that the allowable shearing stress is 65 MPa and that the angle of twist must not exceed 3° , determine the minimum frequency at which the shaft can rotate.

SOLUTION

$$c_1 = \frac{1}{2}d_1 = 0.021 \text{ m}, \quad c_2 = \frac{1}{2}d_2 = 0.015 \text{ m}$$

$$J = \frac{\pi}{2}(c_1^4 - c_2^4) = \frac{\pi}{2}(0.021^4 - 0.015^4) = 225.97 \times 10^{-9} \text{ m}^4$$

Based on stress limit: $\tau = 65 \text{ MPa} = 65 \times 10^6 \text{ Pa}$

$$\tau = \frac{Tc_1}{J} \quad \text{or} \quad T = \frac{J\tau}{c_1} = \frac{(225.97 \times 10^{-9})(65 \times 10^6)}{0.021} = 699.43 \text{ N} \cdot \text{m}$$

Based on angle of twist limit: $\phi = 3^\circ = 52.36 \times 10^{-3} \text{ rad}$

$$\phi = \frac{TL}{GJ} \quad \text{or} \quad T = \frac{GJ\phi}{L} = \frac{(77 \times 10^9)(225.97 \times 10^{-9})(52.36 \times 10^{-3})}{1.6} \\ = 569.40 \text{ N} \cdot \text{m}$$

Smaller torque governs. $T = 569.40 \text{ N} \cdot \text{m}$

$$P = 120 \text{ kW} = 120 \times 10^3 \text{ W}$$

$$P = 2\pi fT \quad \text{so} \quad f = \frac{P}{2\pi T} = \frac{120 \times 10^3}{2\pi(569.40)} \quad f = 33.5 \text{ Hz} \quad \blacktriangleleft$$

$$\text{or } 2010 \text{ rpm} \quad \blacktriangleleft$$

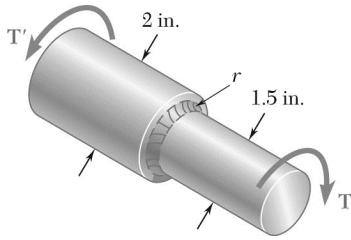

PROBLEM 3.84

Knowing that the stepped shaft shown transmits a torque of magnitude $T = 2.50 \text{ kip} \cdot \text{in.}$, determine the maximum shearing stress in the shaft when the radius of the fillet is (a) $r = \frac{1}{8} \text{ in.}$, (b) $r = \frac{3}{16} \text{ in.}$

SOLUTION

$$D = 2 \text{ in.} \quad d = 1.5 \text{ in.} \quad \frac{D}{d} = \frac{2}{1.5} = 1.33$$

$$c = \frac{1}{2}d = 0.75 \text{ in.} \quad T = 2.5 \text{ kip} \cdot \text{in.}$$

$$\frac{Tc}{J} = \frac{2T}{\pi c^3} = \frac{(2)(2.5)}{\pi(0.75)^3} = 3.773 \text{ ksi}$$

(a) $r = \frac{1}{8} \text{ in.} \quad r = 0.125 \text{ in.}$

$$\frac{r}{d} = \frac{0.125}{1.5} = 0.0833$$

From Fig. 3.32, $K = 1.42$

$$\tau_{\max} = K \frac{Tc}{J} = (1.42)(3.773)$$

$$\tau_{\max} = 5.36 \text{ ksi} \quad \blacktriangleleft$$

(b) $r = \frac{3}{16} \text{ in.} \quad r = 0.1875 \text{ in.}$

$$\frac{r}{d} = \frac{0.1875}{1.5} = 0.125$$

From Fig. 3.32, $K = 1.33$

$$\tau_{\max} = K \frac{Tc}{J} = (1.33)(3.773)$$

$$\tau_{\max} = 5.02 \text{ ksi} \quad \blacktriangleleft$$

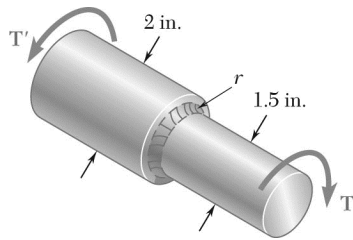

PROBLEM 3.85

Knowing that the allowable shearing stress is 8 ksi for the stepped shaft shown, determine the magnitude T of the largest torque that can be transmitted by the shaft when the radius of the fillet is (a) $r = \frac{3}{16}$ in.,

(b) $r = \frac{1}{4}$ in.

SOLUTION

$$D = 2 \text{ in.} \quad d = 1.5 \text{ in.} \quad \frac{D}{d} = 1.33$$

$$c = \frac{1}{2}d = 0.75 \text{ in.} \quad \tau_{\max} = 8 \text{ ksi}$$

$$\tau_{\max} = K \frac{Tc}{J} \quad \text{or} \quad T = \frac{J\tau_{\max}}{Kc} = \frac{\pi\tau_{\max}c^3}{2K}$$

$$(a) \quad r = \frac{3}{16} \text{ in.} \quad r = 0.1875 \text{ in.}$$

$$\frac{r}{d} = \frac{0.1875}{1.5} = 0.125$$

$$\text{From Fig. 3.32,} \quad K = 1.33$$

$$T = \frac{\pi(8)(0.75)^3}{(2)(1.33)}$$

$$T = 3.99 \text{ kip} \cdot \text{in} \quad \blacktriangleleft$$

$$(b) \quad r = \frac{1}{4} \text{ in.} \quad r = 0.25 \text{ in.}$$

$$\frac{r}{d} = \frac{0.25}{1.5} = 0.1667$$

$$\text{From Fig. 3.32,} \quad K = 1.27$$

$$T = \frac{\pi(8)(0.75)^3}{(2)(1.27)}$$

$$T = 4.17 \text{ kip} \cdot \text{in} \quad \blacktriangleleft$$

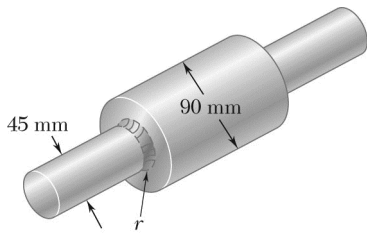

PROBLEM 3.86

The stepped shaft shown must transmit 40 kW at a speed of 720 rpm. Determine the minimum radius r of the fillet if an allowable stress of 36 MPa is not to be exceeded.

SOLUTION

Angular speed: $f = (720 \text{ rpm}) \left(\frac{1 \text{ Hz}}{60 \text{ rpm}} \right) = 12 \text{ Hz}$

Power: $P = 40 \times 10^3 \text{ W}$

Torque: $T = \frac{P}{2\pi f} = \frac{40 \times 10^3}{2\pi(12)} = 530.52 \text{ N} \cdot \text{m}$

In the smaller shaft, $d = 45 \text{ mm}$, $c = 22.5 \text{ mm} = 0.0225 \text{ m}$

$$\tau = \frac{Tc}{J} = \frac{2T}{\pi c^3} = \frac{(2)(530.52)}{\pi(0.0225)^3} = 29.65 \times 10^6 \text{ Pa}$$

Using $\tau_{\max} = 36 \text{ MPa} = 36 \times 10^6 \text{ Pa}$ results in

$$K = \frac{\tau_{\max}}{\tau} = \frac{36 \times 10^6}{29.65 \times 10^6} = 1.214$$

From Fig 3.32 with $\frac{D}{d} = \frac{90 \text{ mm}}{45 \text{ mm}} = 2$, $\frac{r}{d} = 0.24$

$$r = 0.24d = (0.24)(45 \text{ mm})$$

$$r = 10.8 \text{ mm} \blacktriangleleft$$

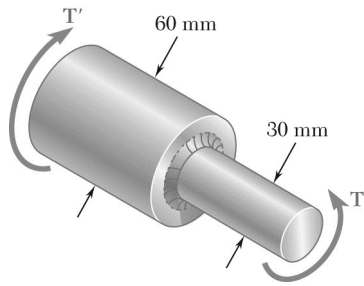

PROBLEM 3.87

The stepped shaft shown must transmit 45 kW. Knowing that the allowable shearing stress in the shaft is 40 MPa and that the radius of the fillet is $r = 6$ mm, determine the smallest permissible speed of the shaft.

SOLUTION

$$\frac{r}{d} = \frac{6}{30} = 0.2$$

$$\frac{D}{d} = \frac{60}{30} = 2$$

From Fig. 3.32,

$$K = 1.26$$

For smaller side,

$$c = \frac{1}{2}d = 15 \text{ mm} = 0.015 \text{ m}$$

$$\tau = \frac{KTc}{J} = \frac{2KT}{\pi c^3}$$

$$T = \frac{\pi c^3 \tau}{2K} = \frac{\pi(0.015)^3(40 \times 10^6)}{(2)(1.26)} = 168.30 \text{ N} \cdot \text{m}$$

$$P = 45 \text{ kW} = 45 \times 10^3 \quad P = 2\pi fT$$

$$f = \frac{P}{2\pi T} = \frac{45 \times 10^3}{2\pi(168.30 \times 10^3)} = 42.6 \text{ Hz}$$

$$f = 42.6 \text{ Hz} \quad \blacktriangleleft$$

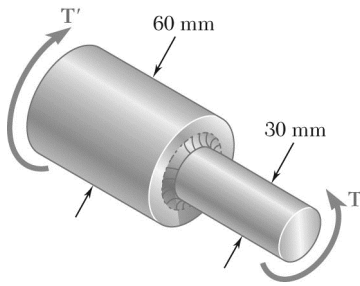

PROBLEM 3.88

The stepped shaft shown must rotate at a frequency of 50 Hz. Knowing that the radius of the fillet is $r = 8$ mm and the allowable shearing stress is 45 MPa, determine the maximum power that can be transmitted.

SOLUTION

$$\tau = \frac{KTc}{J} = \frac{2KT}{\pi c^3} \quad T = \frac{\pi c^3 \tau}{2K}$$

$$d = 30 \text{ mm} \quad c = \frac{1}{2}d = 15 \text{ mm} = 15 \times 10^{-3} \text{ m}$$

$$D = 60 \text{ mm}, \quad r = 8 \text{ mm}$$

$$\frac{D}{d} = \frac{60}{30} = 2, \quad \frac{r}{d} = \frac{8}{30} = 0.26667$$

From Fig. 3.32,

$$K = 1.18$$

Allowable torque.

$$T = \frac{\pi(15 \times 10^{-3})^3(45 \times 10^6)}{(2)(1.18)} = 202.17 \text{ N} \cdot \text{m}$$

Maximum power.

$$P = 2\pi f T = (2\pi)(50)(202.17) = 63.5 \times 10^3 \text{ W}$$

$$P = 63.5 \text{ kW} \quad \blacktriangleleft$$

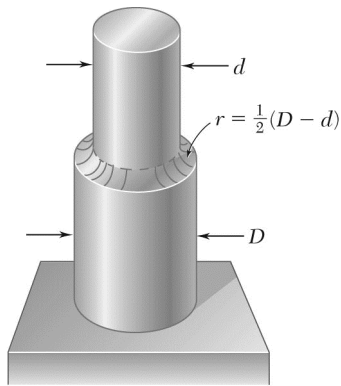

PROBLEM 3.89

In the stepped shaft shown, which has a full quarter-circular fillet, $D = 1.25$ in. and $d = 1$ in. Knowing that the speed of the shaft is 2400 rpm and that the allowable shearing stress is 7500 psi, determine the maximum power that can be transmitted by the shaft.

Full quarter-circular fillet extends to edge of larger shaft.

SOLUTION

$$\frac{D}{d} = \frac{1.25}{1.0} = 1.25$$

$$r = \frac{1}{2}(D - d) = 0.15 \text{ in.}$$

$$\frac{r}{d} = \frac{0.15}{1.0} = 0.15$$

From Fig. 3.32,

$$K = 1.31$$

For smaller side,

$$c = \frac{1}{2}d = 0.5 \text{ in.}$$

$$\tau = \frac{KTc}{J} \quad T = \frac{J\tau}{Kc} = \frac{\pi c^3 \tau}{2K}$$

$$T = \frac{\pi(0.5)^3(7500)}{(2)(1.31)} = 1.1241 \times 10^3 \text{ lb} \cdot \text{in}$$

$$f = 2400 \text{ rpm} = 40 \text{ Hz}$$

$$P = 2\pi f T = 2\pi(40)(1.1241 \times 10^3)$$

$$= 282.5 \times 10^3 \text{ lb} \cdot \text{in/s}$$

$$P = 42.8 \text{ hp} \quad \blacktriangleleft$$

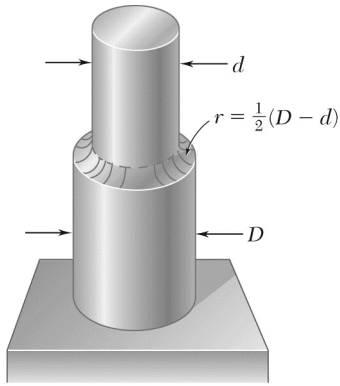

Full quarter-circular fillet extends to edge of larger shaft.

PROBLEM 3.90

A torque of magnitude $T = 200 \text{ lb} \cdot \text{in.}$ is applied to the stepped shaft shown, which has a full quarter-circular fillet. Knowing that $D = 1 \text{ in.}$, determine the maximum shearing stress in the shaft when (a) $d = 0.8 \text{ in.}$, (b) $d = 0.9 \text{ in.}$

SOLUTION

$$(a) \quad \frac{D}{d} = \frac{1.0}{0.8} = 1.25$$

$$r = \frac{1}{2}(D - d) = 0.1 \text{ in.}$$

$$\frac{r}{d} = \frac{0.1}{0.8} = 0.125$$

From Fig. 3.32,

$$K = 1.31$$

For smaller side,

$$c = \frac{1}{2}d = 0.4 \text{ in.}$$

$$\tau = \frac{KTc}{J} = \frac{2KT}{\pi c^3}$$

$$= \frac{(2)(1.31)(200)}{\pi(0.4)^3} = 2.61 \times 10^3 \text{ psi}$$

$$\tau = 2.61 \text{ ksi} \quad \blacktriangleleft$$

$$(b) \quad \frac{D}{d} = \frac{1.0}{0.9} = 1.111$$

$$r = \frac{1}{2}(D - d) = 0.05$$

$$\frac{r}{d} = \frac{0.05}{1.0} = 0.05$$

From Fig. 3.32,

$$K = 1.44$$

For smaller side,

$$c = \frac{1}{2}d = 0.45 \text{ in.}$$

$$\tau = \frac{2KT}{\pi c^3} = \frac{(2)(1.44)(200)}{\pi(0.45)^3} = 2.01 \times 10^3 \text{ psi}$$

$$\tau = 2.01 \text{ ksi} \quad \blacktriangleleft$$

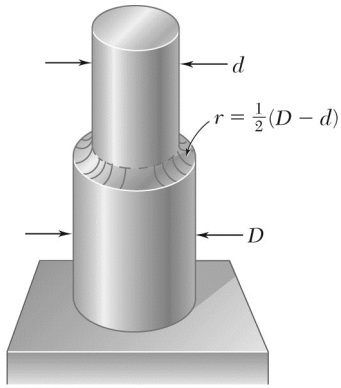

Full quarter-circular fillet extends to edge of larger shaft

PROBLEM 3.91

In the stepped shaft shown, which has a full quarter-circular fillet, the allowable shearing stress is 80 MPa. Knowing that $D = 30$ mm, determine the largest allowable torque that can be applied to the shaft if (a) $d = 26$ mm, (b) $d = 24$ mm.

SOLUTION

$$\tau = 80 \times 10^6 \text{ Pa}$$

$$(a) \quad \frac{D}{d} = \frac{30}{26} = 1.154 \quad r = \frac{1}{2}(D - d) = 2 \text{ mm} \quad \frac{r}{d} = \frac{2}{26} = 0.0768$$

$$\text{From Fig. 3.32,} \quad K = 1.36$$

$$\text{Smaller side,} \quad c = \frac{1}{2}d = 13 \text{ mm} = 0.013 \text{ m}$$

$$\tau = \frac{KTc}{J} = \frac{2KT}{\pi c^3}$$

$$T = \frac{\pi c^3 \tau}{2K} = \frac{\pi(0.013)^3(80 \times 10^6)}{(2)(1.36)} = 203 \text{ N} \cdot \text{m} \quad T = 203 \text{ N} \cdot \text{m} \quad \blacktriangleleft$$

$$(b) \quad \frac{D}{d} = \frac{30}{24} = 1.25 \quad r = \frac{1}{2}(D - d) = 3 \text{ mm} \quad \frac{r}{d} = \frac{3}{24} = 0.125$$

$$\text{From Fig. 3.32,} \quad K = 1.31$$

$$c = \frac{1}{2}d = 12 \text{ mm} = 0.012 \text{ m}$$

$$T = \frac{\pi c^3 \tau}{2K} = \frac{\pi(0.012)^3(80 \times 10^6)}{(2)(1.31)} = 165.8 \text{ N} \cdot \text{m} \quad T = 165.8 \text{ N} \cdot \text{m} \quad \blacktriangleleft$$

PROBLEM 3.92

A 30-mm diameter solid rod is made of an elastoplastic material with $\tau_Y = 3.5$ MPa. Knowing that the elastic core of the rod is 25 mm in diameter, determine the magnitude of the applied torque T .

SOLUTION

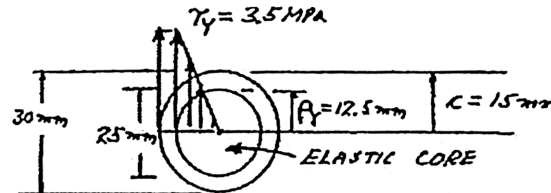

$$\tau_Y = 3.5 \times 10^6 \text{ Pa}, \quad c = \frac{1}{2}(30 \text{ mm}) = 15 \text{ mm} = 0.015 \text{ m}$$

$$\rho_Y = \frac{1}{2}(25 \text{ mm}) = 12.5 \text{ mm} = 0.0125 \text{ m}$$

$$T_Y = \frac{J}{c} \tau_Y = \frac{\pi}{2} c^3 \tau_Y = \frac{\pi}{2} (0.015)^3 (3.5 \times 10^6) = 18.555 \text{ N} \cdot \text{m}$$

$$T = \frac{4}{3} T_Y \left(1 - \frac{\rho_Y^3}{c^3} \right) = \frac{4}{3} (18.555) \left[1 - \frac{(0.0125)^3}{(0.015)^3} \right]$$

$$= 21.2 \text{ N} \cdot \text{m}$$

$$T = 21.2 \text{ N} \cdot \text{m} \quad \blacktriangleleft$$

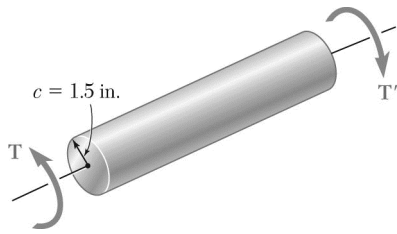

PROBLEM 3.93

The solid circular shaft shown is made of a steel that is assumed to be elastoplastic with $\tau_Y = 21$ ksi. Determine the magnitude T of the applied torques when the plastic zone is (a) 0.8 in. deep, (b) 1.2 in. deep.

SOLUTION

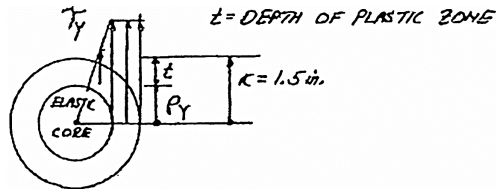

$$\tau_Y = 21 \text{ ksi}$$

$$T_Y = \frac{\tau_Y J}{c} = \tau_Y \frac{\pi}{2} c^3$$

$$= (21 \text{ ksi}) \frac{\pi}{2} (1.5 \text{ in.})^3$$

$$T_Y = 111.3 \text{ kip} \cdot \text{in}$$

(a) For $t = 0.8$ in. $\rho_Y = 1.5 - 0.8 = 0.7$ in.

Eq. (3.32)

$$T = \frac{4}{3} T_Y \left[1 - \frac{1}{4} \frac{\rho_Y^3}{c^3} \right] = \frac{4}{3} (111.3 \text{ kip} \cdot \text{in}) \left[1 - \frac{1}{4} \frac{(0.7 \text{ in.})^3}{(1.5 \text{ in.})^3} \right]$$

$$T = 144.7 \text{ kip} \cdot \text{in} \quad \blacktriangleleft$$

(b) For $t = 1.2$ in. $\rho_Y = 1.5 - 1.2 = 0.3$ in.

$$T = \frac{4}{3} T_Y \left[1 - \frac{1}{4} \frac{\rho_Y^3}{c^3} \right] = \frac{4}{3} (111.3 \text{ kip} \cdot \text{in}) \left[1 - \frac{1}{4} \frac{(0.3 \text{ in.})^3}{(1.5 \text{ in.})^3} \right]$$

$$T = 148.1 \text{ kip} \cdot \text{in} \quad \blacktriangleleft$$

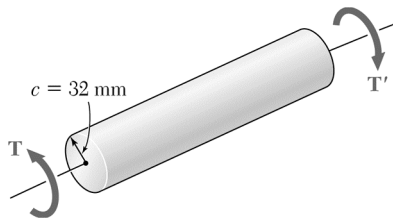

PROBLEM 3.94

The solid circular shaft shown is made of a steel that is assumed to be elastoplastic with $\tau_Y = 145 \text{ MPa}$. Determine the magnitude T of the applied torques when the plastic zone is (a) 16 mm deep, (b) 24 mm deep.

SOLUTION

$$c = 32 \text{ mm} = 0.032 \text{ m}$$

$$\tau_Y = 145 \times 10^6 \text{ Pa}$$

$$T_Y = \frac{J\tau_Y}{c} = \frac{\pi}{2}c^3\tau_Y = \frac{\pi}{2}(0.032)^3(145 \times 10^6)$$

$$= 7.4634 \times 10^3 \text{ N} \cdot \text{m}$$

(a) $t_p = 16 \text{ mm} = 0.016 \text{ m}$

$$\rho_Y = c - t_p = 0.032 - 0.016 = 0.016 \text{ m}$$

$$T = \frac{4}{3}T_Y \left(1 - \frac{1}{4} \frac{\rho_Y^3}{c^3} \right) = \frac{4}{3}(7.4634 \times 10^3) \left(1 - \frac{1}{4} \frac{0.016^3}{0.032^3} \right)$$

$$= 9.6402 \times 10^3 \text{ N} \cdot \text{m}$$

$$T = 9.64 \text{ kN} \cdot \text{m} \quad \blacktriangleleft$$

(b) $t_p = 24 \text{ mm} = 0.024 \text{ m}$

$$\rho_Y = c - t_p = 0.032 - 0.024 = 0.008 \text{ m}$$

$$T = \frac{4}{3}T_Y \left(1 - \frac{1}{4} \frac{\rho_Y^3}{c^3} \right) = \frac{4}{3}(7.4634 \times 10^3) \left(1 - \frac{1}{4} \frac{0.008^3}{0.032^3} \right)$$

$$= 9.9123 \times 10^3 \text{ N} \cdot \text{m}$$

$$T = 9.91 \text{ kN} \cdot \text{m} \quad \blacktriangleleft$$

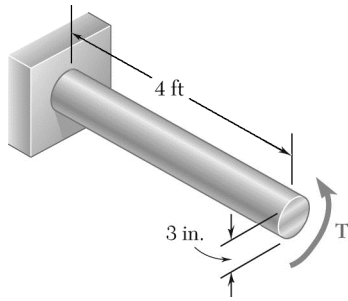

PROBLEM 3.95

The solid shaft shown is made of a mild steel that is assumed to be elastoplastic with $G = 11.2 \times 10^6$ psi and $\tau_Y = 21$ ksi. Determine the maximum shearing stress and the radius of the elastic core caused by the application of torque of magnitude (a) $T = 100$ kip · in., (b) $T = 140$ kip · in.

SOLUTION

$$c = 1.5 \text{ in.}, \quad J = \frac{\pi}{2} c^4 = 7.9522 \text{ in}^4, \quad \tau_Y = 21 \text{ ksi}$$

(a) $T = 100$ kip · in

$$\tau_m = \frac{Tc}{J} = \frac{(100 \text{ kip} \cdot \text{in})(1.5 \text{ in.})}{7.9522 \text{ in}^4} \quad \tau_m = 18.86 \text{ ksi} \quad \blacktriangleleft$$

Since $\tau_m < \tau_Y$, shaft remains elastic.

Radius of elastic core: $c = 1.500$ in. \blacktriangleleft

(b) $T = 140$ kip · in

$$\tau_m = \frac{(140)(1.5)}{7.9522} = 26.4 \text{ ksi.} \quad \text{Impossible: } \tau_m = \tau_Y = 21.0 \text{ ksi} \quad \blacktriangleleft$$

Plastic zone has developed. Torque at onset of yield is $T_Y = \frac{J}{c} \tau_Y = \frac{7.9522}{1.5} (21 \text{ ksi}) = 111.33$ kip · in

$$\text{Eq. (3.32): } T = \frac{4}{3} T_Y \left(1 - \frac{1}{4} \frac{\rho_Y^3}{c^3} \right)$$

$$\left(\frac{\rho_Y}{c} \right)^3 = 4 - 3 \frac{T}{T_Y} = 4 - 3 \frac{140}{111.33} = 0.22743 \quad \frac{\rho_Y}{c} = 0.6104$$

$$\rho_Y = 0.6104c = 0.6104(1.5 \text{ in.}) \quad \rho_Y = 0.916 \text{ in.} \quad \blacktriangleleft$$

PROBLEM 3.96

It is observed that a straightened paper clip can be twisted through several revolutions by the application of a torque of approximately $60 \text{ mN} \cdot \text{m}$. Knowing that the diameter of the wire in the paper clip is 0.9 mm , determine the approximate value of the yield stress of the steel.

SOLUTION

$$c = \frac{1}{2}d = 0.45 \text{ mm} = 0.45 \times 10^{-3} \text{ m}$$

$$T_P = 60 \text{ mN} \cdot \text{m} = 60 \times 10^{-3} \text{ N} \cdot \text{m}$$

$$T_P = \frac{4}{3}T_Y = \frac{4}{3} \frac{J\tau_Y}{c} = \frac{4}{3} \cdot \frac{\pi}{2} c^3 T_Y = \frac{2\pi}{3} c^3 \tau_Y$$

$$\tau_Y = \frac{3T_P}{2\pi c^3} = \frac{(3)(60 \times 10^{-3})}{2\pi (0.45 \times 10^{-3})^3} = 314 \times 10^6 \text{ Pa} \quad \tau_Y = 314 \text{ MPa} \blacktriangleleft$$

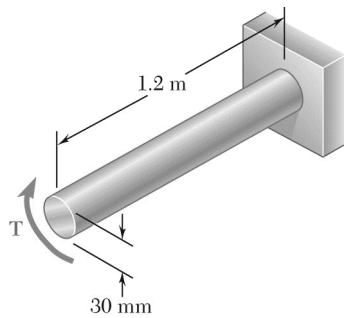

PROBLEM 3.97

The solid shaft shown is made of a mild steel that is assumed to be elastoplastic with $\tau_Y = 145$ MPa. Determine the radius of the elastic core caused by the application of a torque equal to $1.1 T_Y$, where T_Y is the magnitude of the torque at the onset of yield.

SOLUTION

$$c = \frac{1}{2}d = 15 \text{ mm} \quad T = \frac{4}{3}T_Y \left[1 - \left(\frac{\rho_Y}{c} \right)^3 \right]$$

$$\frac{\rho_Y}{c} = \sqrt[3]{4 - 3 \frac{T}{T_Y}} = \sqrt[3]{4 - (3)(1.1)} = 0.88790$$

$$\rho_Y = 0.88790c = (0.88790)(15 \text{ mm})$$

$$\rho_Y = 13.32 \text{ mm} \quad \blacktriangleleft$$

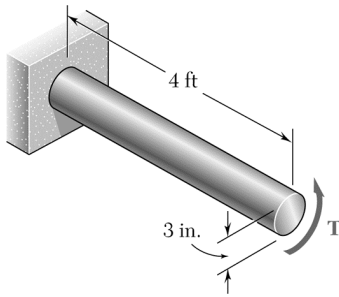

PROBLEM 3.98

For the solid circular shaft of Prob. 3.95, determine the angle of twist caused by the application of a torque of magnitude (a) $T = 80 \text{ kip} \cdot \text{in.}$, (b) $T = 130 \text{ kip} \cdot \text{in.}$

SOLUTION

$$c = \frac{1}{2}d = \frac{1}{2}(3) = 1.5 \text{ in.} \quad \tau_Y = 21 \times 10^3 \text{ psi}$$

$$L = 4 \text{ ft} = 48 \text{ in.} \quad J = \frac{\pi}{2}c^4 = \frac{\pi}{2}(1.5)^4 = 7.9522 \text{ in}^4$$

Torque at onset of yielding: $\tau = \frac{Tc}{J} \quad T = \frac{\tau J}{c}$

$$T_Y = \frac{\tau_Y J}{c} = \frac{(21 \times 10^3)(7.9522)}{1.5} = 111.330 \times 10^3 \text{ lb} \cdot \text{in}$$

(a) $T = 80 \text{ kip} \cdot \text{in} = 80 \times 10^3 \text{ lb} \cdot \text{in}$

Since $T < T_Y$, the shaft is fully elastic. $\phi = \frac{TL}{GJ}$

$$\phi = \frac{(80 \times 10^3)(48)}{(11.2 \times 10^6)(7.9522)} = 43.115 \times 10^{-3} \text{ rad} \quad \phi = 2.47^\circ \blacktriangleleft$$

(b) $T = 130 \text{ kip} \cdot \text{in} = 130 \times 10^3 \text{ lb} \cdot \text{in}$ $T > T_Y \quad T = \frac{4}{3}T_Y \left[1 - \left(\frac{\phi_Y}{\phi} \right)^3 \right]$

$$\phi_Y = \frac{T_Y L}{GJ} = \frac{(111.330 \times 10^3)(48)}{(11.2 \times 10^6)(7.9522)} = 60.000 \times 10^{-3} \text{ rad}$$

$$\frac{\phi_Y}{\phi} = \sqrt[3]{4 - 3 \frac{T}{T_Y}} = \sqrt[3]{4 - \frac{(3)(130 \times 10^3)}{111.330 \times 10^3}} = 0.79205$$

$$\phi = \frac{\phi_Y}{0.79205} = \frac{60.000 \times 10^{-3}}{0.79205} = 75.75 \times 10^{-3} \text{ rad} \quad \phi = 4.34^\circ \blacktriangleleft$$

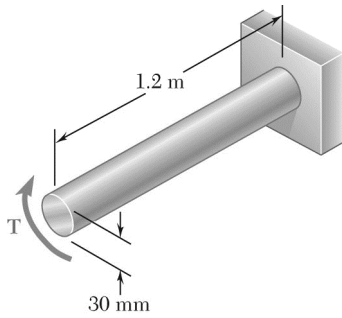

PROBLEM 3.99

The solid shaft shown is made of a mild steel that is assumed to be elastoplastic with $G = 77.2$ GPa and $\tau_Y = 145$ MPa. Determine the angle of twist caused by the application of a torque of magnitude (a) $T = 600$ N · m, (b) $T = 1000$ N · m.

SOLUTION

$$c = \frac{1}{2}d = 15 \text{ mm} = 15 \times 10^{-3} \text{ m}$$

Torque at onset of yielding: $\tau = \frac{Tc}{J} = \frac{2T}{\pi c^3}$

$$T_Y = \frac{\pi c^3 \tau_Y}{2} = \frac{\pi (15 \times 10^{-3})^3 (145 \times 10^6)}{2} = 768.71 \text{ N} \cdot \text{m}$$

(a) $T = 600$ N · m. Since $T \leq T_Y$, the shaft is elastic.

$$\phi = \frac{TL}{GJ} = \frac{2TL}{\pi c^4 G} = \frac{(2)(600)(1.2)}{\pi (15 \times 10^{-3})^4 (77.2 \times 10^9)} = 0.11728 \text{ rad} \quad \phi = 6.72^\circ \blacktriangleleft$$

(b) $T = 1000$ N · m. $T > T_Y$. A plastic zone has developed.

$$T = \frac{4}{3}T_Y \left[1 - \left(\frac{\phi_Y}{\phi} \right)^3 \right] \quad \frac{\phi_Y}{\phi} = \sqrt[3]{4 - 3 \left(\frac{T}{T_Y} \right)}$$

$$\phi_Y = \frac{T_Y L}{GJ} = \frac{2T_Y L}{\pi c^4 G} = \frac{(2)(768.71)(2.1)}{\pi (15 \times 10^{-3})^4 (77.2 \times 10^9)} = 0.15026 \text{ rad}$$

$$\frac{\phi_Y}{\phi} = \sqrt[3]{4 - \frac{(3)(1000)}{768.71}} = 0.46003$$

$$\phi = \frac{\phi_Y}{0.46003} = \frac{0.15026}{0.46003} = 0.32663 \text{ rad} \quad \phi = 18.71^\circ \blacktriangleleft$$

PROBLEM 3.100

A 3-ft-long solid shaft has a diameter of 2.5 in. and is made of a mild steel that is assumed to be elastoplastic with $\tau_Y = 21$ ksi and $G = 11.2 \times 10^6$ psi. Determine the torque required to twist the shaft through an angle of (a) 2.5° , (b) 5° .

SOLUTION

$$L = 3 \text{ ft} = 36 \text{ in.}, \quad c = \frac{1}{2}d = 1.25 \text{ in.}, \quad \tau_Y = 21 \times 10^3 \text{ psi}$$

$$J = \frac{\pi}{2}c^4 = \frac{\pi}{2}(1.25)^4 = 3.835 \text{ in}^4$$

$$\tau_Y = \frac{T_Y c}{J} \quad T_Y = \frac{J \tau_Y}{c} = \frac{(3.835)(21 \times 10^3)}{1.25} = 64.427 \times 10^3 \text{ lb} \cdot \text{in}$$

$$\phi_Y = \frac{T_Y L}{GJ} = \frac{(64.427 \times 10^3)(36)}{(11.2 \times 10^6)(3.835)} = 53.999 \times 10^{-3} \text{ rad} = 3.0939^\circ$$

(a) $\phi = 2.5^\circ = 43.633 \times 10^{-3} \text{ rad}$ $\phi < \phi_Y$ The shaft remains elastic.

$$\phi = \frac{TL}{GJ}$$

$$T = \frac{GJ\phi}{L} = \frac{(11.2 \times 10^6)(3.835)(43.633 \times 10^{-3})}{36}$$

$$= 52.059 \times 10^3 \text{ lb} \cdot \text{in}$$

$$T = 52.1 \text{ kip} \cdot \text{in} \quad \blacktriangleleft$$

(b) $\phi = 5^\circ = 87.266 \times 10^{-3} \text{ rad}$ $\phi > \phi_Y$ A plastic zone occurs.

$$T = \frac{4}{3}T_Y \left[1 - \frac{1}{4} \left(\frac{\phi_Y}{\phi} \right)^3 \right]$$

$$= \frac{4}{3}(64.427 \times 10^3) \left[1 - \frac{1}{4} \left(\frac{53.999 \times 10^{-3}}{87.266 \times 10^{-3}} \right)^3 \right]$$

$$= 80.814 \times 10^3 \text{ lb} \cdot \text{in}$$

$$T = 80.8 \text{ kip} \cdot \text{in} \quad \blacktriangleleft$$

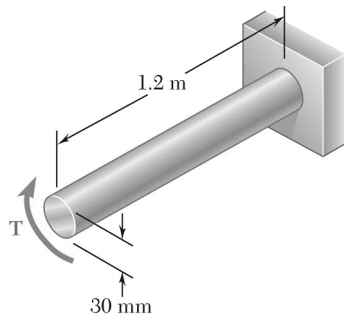

PROBLEM 3.101

For the solid shaft of Prob. 3.99, determine (a) the magnitude of the torque T required to twist the shaft through an angle of 15° , (b) the radius of the corresponding elastic core.

PROBLEM 3.99 The solid shaft shown is made of a mild steel that is assumed to be elastoplastic with $G = 77.2$ GPa and $\tau_Y = 145$ MPa. Determine the angle of twist caused by the application of a torque of magnitude (a) $T = 600$ N · m, (b) $T = 1000$ N · m.

SOLUTION

$$c = \frac{1}{2}d = 15 \text{ mm} = 15 \times 10^{-3} \text{ m}$$

$$\phi = 15^\circ = 0.2618 \text{ rad}$$

$$\phi_Y = \frac{L\gamma_Y}{c} = \frac{L\tau_Y}{cG} = \frac{(1.2)(145 \times 10^6)}{(15 \times 10^{-3})(77.2 \times 10^9)} = 0.15026 \text{ rad}$$

(a) Since $\phi > \phi_Y$, there is a plastic zone.

$$\tau_Y = \frac{T_Y c}{J} = \frac{2T_Y}{\pi c^3}$$

$$T_Y = \frac{\pi c^3 \tau_Y}{2} = \frac{\pi (15 \times 10^{-3})^3 (145 \times 10^6)}{2} = 768.71 \text{ N} \cdot \text{m}$$

$$T = \frac{4}{3} T_Y \left[1 - \frac{1}{4} \left(\frac{\phi_Y}{\phi} \right)^3 \right] = \frac{4}{3} (768.71) \left[1 - \frac{1}{4} \left(\frac{0.15026}{0.2618} \right)^3 \right]$$

$$= 976.5 \text{ N} \cdot \text{m} \qquad T = 977 \text{ N} \cdot \text{m} \blacktriangleleft$$

(b) $L\gamma_Y = \rho_Y \phi = c\phi_Y$

$$\rho_Y = \frac{c\phi_Y}{\phi} = \frac{(15 \times 10^{-3})(0.15026)}{0.2618} = 8.61 \times 10^{-3} \text{ m} \qquad \rho_Y = 8.61 \text{ mm} \blacktriangleleft$$

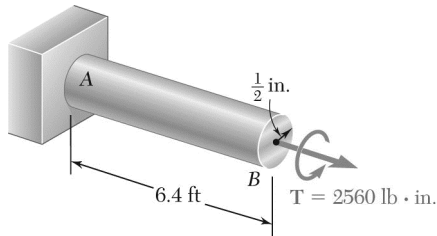

PROBLEM 3.102

The shaft AB is made of a material that is elastoplastic with $\tau_Y = 12 \text{ ksi}$ and $G = 4.5 \times 10^6 \text{ psi}$. For the loading shown, determine (a) the radius of the elastic core of the shaft, (b) the angle of twist at end B .

SOLUTION

(a) Radius of elastic core.

$$c = 0.5 \text{ in.} \quad \tau_Y = 12 \times 10^3 \text{ psi}$$

$$T_Y = \frac{J\tau_Y}{c} = \frac{\pi}{2}c^3\tau_Y = \frac{\pi}{2}(0.5)^3(12 \times 10^3) \\ = 2356.2 \text{ lb} \cdot \text{in}$$

$$T = 2560 \text{ lb} \cdot \text{in} > T_Y \text{ (plastic region with elastic core)}$$

$$T = \frac{4}{3}T_Y \left(1 - \frac{1}{4} \frac{\rho_Y^3}{c^3} \right)$$

$$\frac{\rho_Y^3}{c^3} = 4 - \frac{3T}{T_Y} = 4 - \frac{(3)(2560)}{2356.2} = 0.74051$$

$$\frac{\rho_Y}{c} = 0.9047 \quad \rho_Y = (0.9047)(0.5)$$

$$\rho_Y = 0.452 \text{ in.} \quad \blacktriangleleft$$

(b) Angle of twist.

$$L = 6.4 \text{ ft} = 76.8 \text{ in.} \quad G = 4.5 \times 10^6 \text{ psi}$$

$$\phi_Y = \frac{T_Y L}{JG} = \frac{2T_Y L}{\pi c^4 G} = \frac{(2)(2356.2)(76.8)}{\pi(0.5)^4(4.5 \times 10^6)} = 0.4096 \text{ radians}$$

$$\frac{\phi_Y}{\phi} = \frac{\rho_Y}{c} \quad \phi = \frac{\phi_Y c}{\rho_Y} = \frac{0.4096}{0.9047} = 0.4527 \text{ radians}$$

$$\phi = 25.9^\circ \quad \blacktriangleleft$$

PROBLEM 3.103

A 1.25-in.-diameter solid circular shaft is made of a material that is assumed to be elastoplastic with $\tau_Y = 18$ ksi and $G = 11.2 \times 10^6$ psi. For an 8-ft length of the shaft, determine the maximum shearing stress and the angle of twist caused by a 7.5 kip · in. torque.

SOLUTION

$$c = \frac{1}{2}d = 0.625 \text{ in.}, \quad G = 11.2 \times 10^6 \text{ psi}, \quad \tau_Y = 18 \text{ ksi} = 18000 \text{ psi}$$

$$L = 8 \text{ ft} = 96 \text{ in.} \quad T = 7.5 \text{ kip} \cdot \text{in} = 7.5 \times 10^3 \text{ lb} \cdot \text{in}$$

$$T_Y = \frac{J\tau_Y}{c} = \frac{\pi}{2}c^3\tau_Y = \frac{\pi}{2}(0.625)^3(18000) = 6.9029 \times 10^3 \text{ lb} \cdot \text{in}$$

$$T > T_Y: \text{ plastic region with elastic core} \quad \therefore \tau_{\max} = \tau_Y = 18 \text{ ksi} \quad \tau_{\max} = 18 \text{ ksi} \blacktriangleleft$$

$$\gamma_Y = \frac{c\phi_Y}{L} \quad \therefore \phi_Y = \frac{L\gamma_Y}{c} = \frac{L\tau_Y}{cG} = \frac{(96)(18000)}{(0.625)(11.2 \times 10^6)} = 246.86 \times 10^{-3} \text{ rad}$$

$$T = \frac{4}{3}T_Y \left(1 - \frac{1}{4} \frac{\phi_Y^3}{\phi^3} \right)$$

$$\frac{\phi}{\phi_Y} = \frac{1}{\sqrt[3]{4 - \frac{3T}{T_Y}}} = \frac{1}{\sqrt[3]{4 - \frac{(3)(7.5 \times 10^3)}{6.9029 \times 10^3}}} = 1.10533$$

$$\phi = 1.10533\phi_Y = (1.10533)(246.86 \times 10^{-3}) = 272.86 \times 10^{-3} \text{ rad} \quad \phi = 15.63^\circ \blacktriangleleft$$

PROBLEM 3.104

A 18-mm-diameter solid circular shaft is made of a material that is assumed to be elastoplastic with $\tau_Y = 145 \text{ MPa}$ and $G = 77 \text{ GPa}$. For a 1.2-m length of the shaft, determine the maximum shearing stress and the angle of twist caused by a $200 \text{ N} \cdot \text{m}$ torque.

SOLUTION

$$\tau_Y = 145 \times 10^6 \text{ Pa}, \quad c = \frac{1}{2}d = 0.009 \text{ m}, \quad L = 1.2 \text{ m}, \quad T = 200 \text{ N} \cdot \text{m}$$

$$T_Y = \frac{J\tau_Y}{c} = \frac{\pi}{2}c^3\tau_Y = \frac{\pi}{2}(0.009)^3(145 \times 10^6) = 166.04 \text{ N} \cdot \text{m}$$

$T > T_Y$ (plastic region with elastic core)

$$\tau_{\max} = \tau_Y = 145 \text{ MPa} \quad \blacktriangleleft$$

$$\phi_Y = \frac{T_Y L}{GJ} = \frac{2T_Y L}{\pi c^4 G} = \frac{(2)(166.04)(1.2)}{\pi(0.009)^4(77 \times 10^9)} = 251.08 \times 10^{-3} \text{ radians}$$

$$T = \frac{4}{3}T_Y \left(1 - \frac{1}{4} \frac{\phi^3}{\phi_Y^3}\right)$$

$$\left(\frac{\phi_Y}{\phi}\right)^3 = 4 - \frac{3T}{T_Y} = 4 - \frac{(3)(200)}{166.04} = 0.38641 \quad \frac{\phi_Y}{\phi} = 0.72837$$

$$\phi = \frac{\phi_Y}{0.72837} = \frac{251.08 \times 10^{-3}}{0.72837} = 344.7 \times 10^{-3} \text{ radians}$$

$$\phi = 19.75^\circ \quad \blacktriangleleft$$

PROBLEM 3.105

A solid circular rod is made of a material that is assumed to be elastoplastic. Denoting by T_Y and φ_Y , respectively, the torque and the angle of twist at the onset of yield, determine the angle of twist if the torque is increased to (a) $T = 1.1 T_Y$, (b) $T = 1.25 T_Y$, (c) $T = 1.3 T_Y$.

SOLUTION

$$T = \frac{4}{3} T_Y \left(1 - \frac{1}{4} \frac{\varphi_Y^3}{\varphi^3} \right)$$

$$\frac{\varphi_Y}{\varphi} = \sqrt[3]{4 - \frac{3T}{T_Y}} \quad \text{or} \quad \frac{\varphi}{\varphi_Y} = \frac{1}{\sqrt[3]{4 - \frac{3T}{T_Y}}}$$

$$(a) \quad \frac{T}{T_Y} = 1.10 \quad \frac{\varphi}{\varphi_Y} = \frac{1}{\sqrt[3]{4 - (3)(1.10)}} = 1.126 \quad \varphi = 1.126 \varphi_Y \quad \blacktriangleleft$$

$$(b) \quad \frac{T}{T_Y} = 1.25 \quad \frac{\varphi}{\varphi_Y} = \frac{1}{\sqrt[3]{4 - (3)(1.25)}} = 1.587 \quad \varphi = 1.587 \varphi_Y \quad \blacktriangleleft$$

$$(c) \quad \frac{T}{T_Y} = 1.3 \quad \frac{\varphi}{\varphi_Y} = \frac{1}{\sqrt[3]{4 - (3)(1.3)}} = 2.15 \quad \varphi = 2.15 \varphi_Y \quad \blacktriangleleft$$

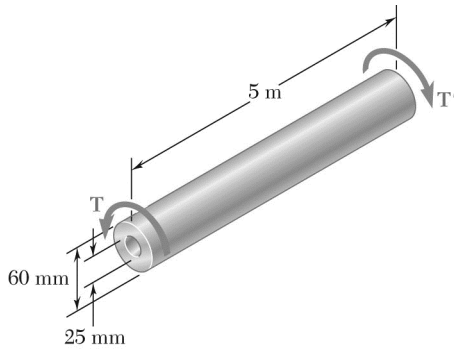

PROBLEM 3.106

The hollow shaft shown is made of a steel that is assumed to be elastoplastic with $\tau_Y = 145 \text{ MPa}$ and $G = 77.2 \text{ GPa}$. Determine the magnitude T of the torque and the corresponding angle of twist (a) at the onset of yield, (b) when the plastic zone is 10 mm deep.

SOLUTION

- (a) At the onset of yield, the stress distribution is the elastic distribution with $\tau_{\max} = \tau_Y$.

$$c_2 = \frac{1}{2}d_2 = 0.030 \text{ m}, \quad c_1 = \frac{1}{2}d_1 = 0.0125 \text{ m}$$

$$J = \frac{\pi}{2}(c_2^4 - c_1^4) = \frac{\pi}{2}(0.030^4 - 0.0125^4) = 1.2340 \times 10^{-6} \text{ m}^4$$

$$\tau_{\max} = \tau_Y = \frac{T_Y c_2}{J} \quad \therefore \quad T_Y = \frac{J \tau_Y}{c_2} = \frac{(1.2340 \times 10^{-6})(145 \times 10^6)}{0.030} = 5.9648 \times 10^3 \text{ N} \cdot \text{m}$$

$$T_Y = 5.96 \text{ kN} \cdot \text{m} \quad \blacktriangleleft$$

$$\phi_Y = \frac{T_Y L}{GJ} = \frac{(5.9648 \times 10^3)(5)}{(77.2 \times 10^9)(1.2340 \times 10^{-6})} = 313.04 \times 10^{-3} \text{ rad}$$

$$\phi_Y = 17.94^\circ \quad \blacktriangleleft$$

- (b) $t = 0.010 \text{ m}$ $\rho_Y = c_2 - t = 0.030 - 0.010 = 0.020 \text{ m}$

$$\gamma = \frac{\rho \phi}{L} = \frac{\rho_Y \phi}{L} = \gamma_Y = \frac{\tau_Y}{G}$$

$$\phi = \frac{\tau_Y L}{G \rho_Y} = \frac{(145 \times 10^6)(5)}{(77.2 \times 10^9)(0.020)} = 469.56 \times 10^{-3} \text{ rad}$$

$$\phi = 26.9^\circ \quad \blacktriangleleft$$

Torque T_1 carried by elastic portion: $c_1 \leq \rho \leq \rho_Y$

$$\tau = \tau_Y \text{ at } \rho = \rho_Y. \quad \tau_Y = \frac{T_1 \rho_Y}{J_1} \quad \text{where} \quad J_1 = \frac{\pi}{2}(\rho_Y^4 - c_1^4)$$

$$J_1 = \frac{\pi}{2}(0.020^4 - 0.0125^4) = 212.978 \times 10^{-9} \text{ m}^4$$

$$T_1 = \frac{J_1 \tau_Y}{\rho_Y} = \frac{(212.978 \times 10^{-9})(145 \times 10^6)}{0.020} = 1.5441 \times 10^3 \text{ N} \cdot \text{m}$$

PROBLEM 3.106 (Continued)

Torque T_2 carried by plastic portion:

$$\begin{aligned} T_2 &= 2\pi \int_{\rho_Y}^{c_2} \tau_Y \rho^2 d\rho = 2\pi \tau_Y \frac{\rho^3}{3} \Big|_{\rho_Y}^{c_2} = \frac{2\pi}{3} \tau_Y (c_2^3 - \rho_Y^3) \\ &= \frac{2\pi}{3} (145 \times 10^6)(0.030^3 - 0.020^3) = 5.7701 \times 10^3 \text{ N} \cdot \text{m} \end{aligned}$$

Total torque:

$$T = T_1 + T_2 = 1.5541 \times 10^3 + 5.7701 \times 10^3 = 7.3142 \times 10^3 \text{ N} \cdot \text{m}$$

$$T = 7.31 \text{ kN} \cdot \text{m} \blacktriangleleft$$

PROBLEM 3.107

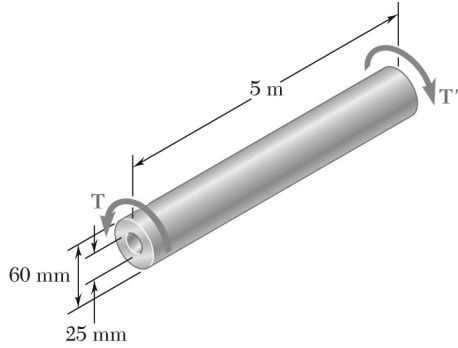

For the shaft of Prob. 3.106, determine (a) angle of twist at which the section first becomes fully plastic, (b) the corresponding magnitude T of the applied torque. Sketch the $T - \phi$ curve for the shaft.

PROBLEM 3.106 The hollow shaft shown is made of a steel that is assumed to be elastoplastic with $\tau_Y = 145 \text{ MPa}$ and $G = 77.2 \text{ GPa}$. Determine the magnitude T of the torque and the corresponding angle of twist (a) at the onset of yield, (b) when the plastic zone is 10 mm deep.

SOLUTION

$$c_1 = \frac{1}{2}d_1 = 0.0125 \text{ m} \quad c_2 = \frac{1}{2}d_2 = 0.030 \text{ m}$$

(a) For onset of fully plastic yielding, $\rho_Y = c_1$

$$\tau = \tau_Y \quad \therefore \quad \gamma = \frac{\tau_Y}{G} = \frac{\rho_Y \phi}{L} = \frac{c_1 \phi}{L}$$

$$\phi_f = \frac{L\tau_Y}{c_1 G} = \frac{(25)(145 \times 10^6)}{(0.0125)(77.2 \times 10^9)} = 751.295 \times 10^{-3} \text{ rad} \quad \phi_f = 43.0^\circ \quad \blacktriangleleft$$

$$(b) \quad T_P = 2\pi \int_{c_1}^{c_2} \tau_Y \rho^2 d\rho = 2\pi \tau_Y \left. \frac{\rho^3}{3} \right|_{c_1}^{c_2} = \frac{2\pi}{3} \tau_Y (c_2^3 - c_1^3)$$

$$= \frac{2\pi}{3} (145 \times 10^6)(0.030^3 - 0.0125^3) = 7.606 \times 10^3 \text{ N} \cdot \text{m} \quad T_P = 7.61 \text{ kN} \cdot \text{m} \quad \blacktriangleleft$$

From Prob. 3.101, $\phi_Y = 17.94^\circ$ $T_Y = 5.96 \text{ kN} \cdot \text{m}$

Also from Prob. 3.101, $\phi = 26.9^\circ$ $T = 7.31 \text{ kN} \cdot \text{m}$

Plot T vs ϕ using the following data.

ϕ , deg	0	17.94	26.9	43.0	>43.0
T kN · m	0	5.96	7.31	7.61	7.61

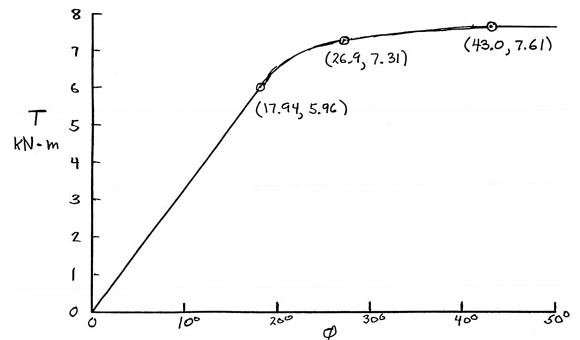

PROBLEM 3.108

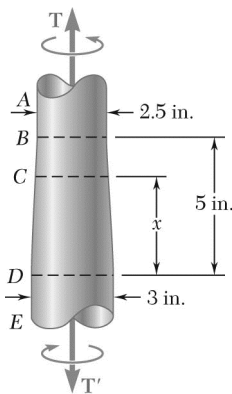

A steel rod is machined to the shape shown to form a tapered solid shaft to which torques of magnitude $T = 75 \text{ kip} \cdot \text{in.}$ are applied. Assuming the steel to be elastoplastic with $\tau_Y = 21 \text{ ksi}$ and $G = 11.2 \times 10^6 \text{ psi}$, determine (a) the radius of the elastic core in portion AB of the shaft, (b) the length of portion CD that remains fully elastic.

SOLUTION

(a) In portion AB .
$$c = \frac{1}{2}d = 1.25 \text{ in.}$$

$$T_Y = \frac{J_{AB}\tau_Y}{c} = \frac{\pi}{2}c^3\tau_Y = \frac{\pi}{2}(1.25)^3(21 \times 10^3) = 64.427 \times 10^3 \text{ lb} \cdot \text{in}$$

$$T = \frac{4}{3}T_Y \left(1 - \frac{\rho_Y^3}{c^3}\right)$$

$$\frac{\rho_Y}{c} = \sqrt[3]{4 - \frac{3T}{T_Y}} = \sqrt[3]{4 - \frac{(3)(75 \times 10^3)}{64.427 \times 10^3}} = 0.79775$$

$$\rho_Y = 0.79775c = (0.79775)(1.25) = 0.99718 \text{ in.} \quad \rho_Y = 0.997 \text{ in.} \quad \blacktriangleleft$$

(b) For yielding at point C . $\tau = \tau_Y, \quad c = c_x, \quad T = 75 \times 10^3 \text{ lb} \cdot \text{in}$

$$T = \frac{J_C\tau_Y}{c_x} = \frac{\pi}{2}c_x^3\tau_Y$$

$$c_x = \sqrt[3]{\frac{2T}{\pi\tau_Y}} = \sqrt[3]{\frac{(2)(75 \times 10^3)}{\pi(21 \times 10^3)}} = 1.31494 \text{ in.}$$

Using proportions from the sketch,

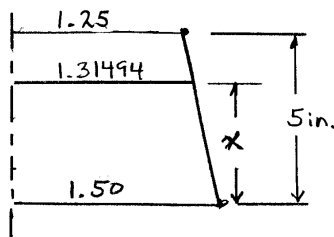

$$\frac{1.50 - 1.31494}{1.50 - 1.25} = \frac{x}{5} \quad x = 3.70 \text{ in.} \quad \blacktriangleleft$$

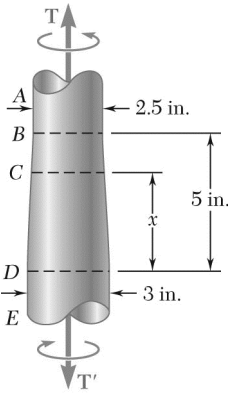

PROBLEM 3.109

If the torques applied to the tapered shaft of Prob. 3.108 are slowly increased, determine (a) the magnitude T of the largest torques that can be applied to the shaft, (b) the length of the portion CD that remains fully elastic.

PROBLEM 3.108 A steel rod is machined to the shape shown to form a tapered solid shaft to which torques of magnitude $T = 75 \text{ kip} \cdot \text{in.}$ are applied. Assuming the steel to be elastoplastic with $\tau_Y = 21 \text{ ksi}$ and $G = 11.2 \times 10^6 \text{ psi}$, determine (a) the radius of the elastic core in portion AB of the shaft, (b) the length of portion CD that remains fully elastic.

SOLUTION

- (a) The largest torque that may be applied is that which makes portion AB fully plastic.

In portion AB ,

$$c = \frac{1}{2}d = 1.25 \text{ in.}$$

$$T_Y = \frac{J\tau_Y}{c} = \frac{\pi}{2}c^3\tau_Y = \frac{\pi}{2}(1.25)^3(21 \times 10^3) = 64.427 \times 10^3 \text{ lb} \cdot \text{in}$$

For fully plastic shaft, $\rho_Y = 0$

$$T = \frac{4}{3}T_Y \left(1 - \frac{1}{4} \frac{\rho_Y^3}{c^3}\right) = \frac{4}{3}T$$

$$T = \frac{4}{3}(64.427 \times 10^3) = 85.903 \times 10^3 \text{ lb} \cdot \text{in} \quad T = 85.9 \text{ kip} \cdot \text{in} \quad \blacktriangleleft$$

- (b) For yielding at point C , $\tau = \tau_Y$, $c = c_x$, $T = 85.903 \times 10^3 \text{ lb} \cdot \text{in}$

$$\tau_Y = \frac{Tc_x}{J_x} = \frac{2T}{\pi c_x^3}$$

$$c_x = \sqrt[3]{\frac{2T}{\pi\tau_Y}} = \sqrt[3]{\frac{(2)(85.903 \times 10^3)}{\pi(21 \times 10^3)}} = 1.37580 \text{ in.}$$

Using proportions from the sketch,

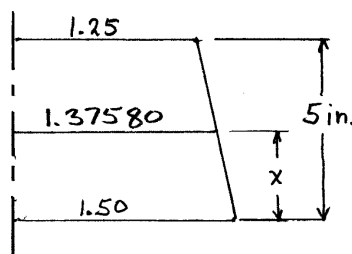

$$\frac{1.50 - 1.37580}{1.50 - 1.25} = \frac{x}{5} \quad x = 2.48 \text{ in.} \quad \blacktriangleleft$$

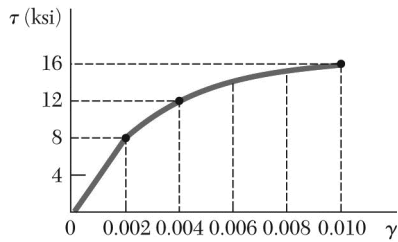

PROBLEM 3.110

A hollow shaft of outer and inner diameters respectively equal to 0.6 in. and 0.2 in. is fabricated from an aluminum alloy for which the stress-strain diagram is given in the diagram shown. Determine the torque required to twist a 9-in. length of the shaft through 10° .

SOLUTION

$$\phi = 10^\circ = 174.53 \times 10^{-3} \text{ rad}$$

$$c_1 = \frac{1}{2}d_1 = 0.100 \text{ in.}, \quad c_2 = \frac{1}{2}d_2 = 0.300 \text{ in.}$$

$$\gamma_{\max} = \frac{c_2\phi}{L} = \frac{(0.300)(174.53 \times 10^{-3})}{9} = 0.00582$$

$$\gamma_{\min} = \frac{c_1\phi}{L} = \frac{(0.100)(174.53 \times 10^{-3})}{9} = 0.00194$$

Let

$$z = \frac{\gamma}{\gamma_{\max}} = \frac{\rho}{c_2} \quad z_1 = \frac{c_1}{c_2} = \frac{1}{3}$$

$$T = 2\pi \int_{c_1}^{c_2} \rho^2 \tau \, d\rho = 2\pi c_2^3 \int_{z_1}^1 z^2 \tau \, dz = 2\pi c_2^3 I$$

where the integral I is given by

$$I = \int_{1/3}^1 z^2 \tau \, dz$$

Evaluate I using a method of numerical integration. If Simpson's rule is used, the integration formula is

$$I = \frac{\Delta z}{3} \Sigma w z^2 \tau$$

where w is a weighting factor. Using $\Delta z = \frac{1}{6}$, we get the values given in the table below.

z	γ	τ , ksi	$z^2 \tau$, ksi	w	$wz^2 \tau$, ksi
1/3	0.00194	8.0	0.89	1	0.89
1/2	0.00291	10.0	2.50	4	10.00
2/3	0.00383	11.5	5.11	2	10.22
5/6	0.00485	13.0	9.03	4	36.11
1	0.00582	14.0	14.0	1	14.00
					71.22

← $\Sigma w z^2 \tau$

$$I = \frac{(1/6)(71.22)}{3} = 3.96 \text{ ksi}$$

$$T = 2\pi c_2^3 I = 2\pi(0.300)^3(3.96) = 0.671 \text{ kip} \cdot \text{in}$$

$$T = 671 \text{ lb} \cdot \text{in} \quad \blacktriangleleft$$

Note: Answer may differ slightly due to differences of opinion in reading the stress-strain curve.

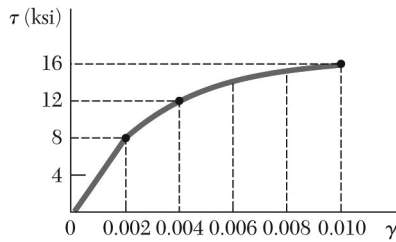

PROBLEM 3.111

Using the stress-strain diagram shown, determine (a) the torque that causes a maximum shearing stress of 15 ksi in a 0.8-in.-diameter solid rod, (b) the corresponding angle of twist in a 20-in. length of the rod.

SOLUTION

(a) $\tau_{\max} = 15 \text{ ksi}$ $c = \frac{1}{2}d = 0.400 \text{ in.}$

From the stress-strain diagram, $\gamma_{\max} = 0.008$

Let $z = \frac{\gamma}{\gamma_{\max}} = \frac{\rho}{c}$

$$T = 2\pi \int_0^c \rho^2 \tau \, d\rho = 2\pi c^3 \int_0^1 z^2 \tau \, dz = 2\pi c^3 I$$

where the integral I is given by $I = \int_0^1 z^2 \tau \, dz$

Evaluate I using a method of numerical integration. If Simpson's rule is used, the integration formula is

$$I = \frac{\Delta z}{3} \sum w z^2 \tau$$

where w is a weighting factor. Using $\Delta z = 0.25$, we get the values given in the table below.

z	γ	τ , ksi	$z^2 \tau$, ksi	w	$wz^2 \tau$, ksi
0	0.000	0	0.000	1	0.00
0.25	0.002	8	0.500	4	2.00
0.5	0.004	12	3.000	2	6.00
0.75	0.006	14	7.875	4	31.50
1.0	0.008	15	15.000	1	15.00
					54.50

← $\sum w z^2 \tau$

$$I = \frac{(0.25)(54.50)}{3} = 4.54 \text{ ksi}$$

$$T = 2\pi c^3 I = 2\pi(0.400)^3(4.54)$$

$$T = 1.826 \text{ kip} \cdot \text{in} \quad \blacktriangleleft$$

(b) $\gamma_{\max} = \frac{c\phi}{L}$

$$\phi = \frac{L\gamma_m}{c} = \frac{(20)(0.008)}{0.400} = 400 \times 10^{-3} \text{ rad}$$

$$\phi = 22.9^\circ \quad \blacktriangleleft$$

Note: Answers may differ slightly due to differences of opinion in reading the stress-strain curve.

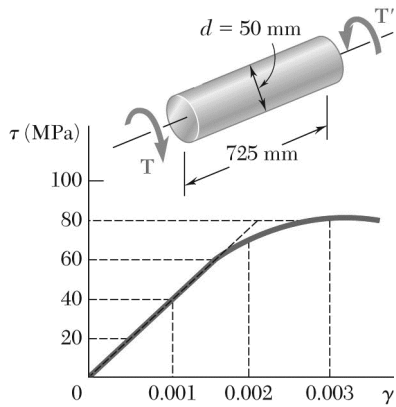

PROBLEM 3.112

A 50-mm-diameter cylinder is made of a brass for which the stress-strain diagram is as shown. Knowing that the angle of twist is 5° in a 725-mm length, determine by approximate means the magnitude T of torque applied to the shaft

SOLUTION

$$\phi = 5^\circ = 87.266 \times 10^{-3} \text{ rad} \quad c = \frac{1}{2}d = 0.025 \text{ m}, \quad L = 0.725 \text{ m}$$

$$\gamma_{\max} = \frac{c\phi}{L} = \frac{(0.025)(87.266 \times 10^{-3})}{0.725} = 0.00301$$

Let $z = \frac{\gamma}{\gamma_{\max}} = \frac{\rho}{c}$

$$T = 2\pi \int_0^c \rho^2 \tau d\rho = 2\pi c^3 \int_0^1 z^2 \tau dz = 2\pi c^3 I \quad \text{where the integral } I \text{ is given by } I = \int_0^1 z^2 \tau dz$$

Evaluate I using a method of numerical integration. If Simpson's rule is used, the integration formula is

$$I = \frac{\Delta z}{3} \sum w z^2 \tau$$

where w is a weighting factor. Using $\Delta z = 0.25$, we get the values given in the table below.

z	γ	τ , MPa	$z^2 \tau$, MPa	w	$w z^2 \tau$, MPa
0	0	0	0	1	0
0.25	0.00075	30	1.875	4	7.5
0.5	0.0015	55	13.75	2	27.5
0.75	0.00226	75	42.19	4	168.75
1.0	0.00301	80	80	1	80
					283.75

$$\leftarrow \sum w z^2 \tau = 283.75 \times 10^6 \text{ Pa}$$

$$I = \frac{(0.25)(283.75 \times 10^6)}{3} = 23.65 \times 10^6 \text{ Pa}$$

$$T = 2\pi c^3 I = 2\pi(0.025)^3(23.65 \times 10^6) = 2.32 \times 10^3 \text{ N} \cdot \text{m}$$

$$T = 2.32 \text{ kN} \cdot \text{m} \blacktriangleleft$$

PROBLEM 3.113

Three points on the nonlinear stress-strain diagram used in Prob. 3.112 are (0,0), (0.0015,55 MPa), and (0.003,80 MPa). By fitting the polynomial $\tau = A + B\gamma + C\gamma^2$ through these points, the following approximate relation has been obtained.

$$T = 46.7 \times 10^9 \gamma - 6.67 \times 10^{12} \gamma^2$$

Solve Prob. 3.113 using this relation, Eq. (3.2), and Eq. (3.26).

PROBLEM 3.112 A 50-mm diameter cylinder is made of a brass for which the stress-strain diagram is as shown. Knowing that the angle of twist is 5° in a 725-mm length, determine by approximate means the magnitude T of torque applied to the shaft.

SOLUTION

$$\varphi = 5^\circ = 87.266 \times 10^{-3} \text{ rad}, \quad c = \frac{1}{2}d = 0.025 \text{ m}, \quad L = 0.725 \text{ m}$$

$$\gamma_{\max} = \frac{c\varphi}{L} = \frac{(0.025)(87.266 \times 10^{-3})}{0.725} = 3.009 \times 10^{-3}$$

Let $z = \frac{\gamma}{\gamma_{\max}} = \frac{\rho}{c}$

$$T = 2\pi \int_0^c \rho^2 \tau d\rho = 2\pi c^3 \int_0^1 z^2 \tau dz$$

The given stress-strain curve is

$$\tau = A + B\gamma + C\gamma^2 = A + B\gamma_{\max} z + C\gamma_{\max}^2 z^2$$

$$\begin{aligned} T &= 2\pi c^3 \int_0^1 z^2 (A + B\gamma_{\max} z + C\gamma_{\max}^2 z^2) dz \\ &= 2\pi c^3 \left\{ A \int_0^1 z^2 dz + B\gamma_{\max} \int_0^1 z^3 dz + C\gamma_{\max}^2 \int_0^1 z^4 dz \right\} \\ &= 2\pi c^2 \left\{ \frac{1}{3}A + \frac{1}{4}B\gamma_{\max} + \frac{1}{5}C\gamma_{\max}^2 \right\} \end{aligned}$$

Data: $A = 0, \quad B = 46.7 \times 10^9, \quad C = -6.67 \times 10^{12}$

$$\frac{1}{3}A = 0, \quad \frac{1}{4}B\gamma_{\max} = \frac{1}{4}(46.7 \times 10^9)(3.009 \times 10^{-3}) = 35.13 \times 10^3$$

$$\frac{1}{5}C\gamma_{\max}^2 = -\frac{1}{5}(6.67 \times 10^{12})(3.009 \times 10^{-3})^2 = -12.08 \times 10^3$$

$$T = 2\pi(0.025)^3(0 + (35.13 \times 10^3 - 12.08 \times 10^3)) = 2.26 \times 10^3 \text{ N} \cdot \text{m}$$

$$T = 2.26 \text{ kN} \cdot \text{m} \blacktriangleleft$$

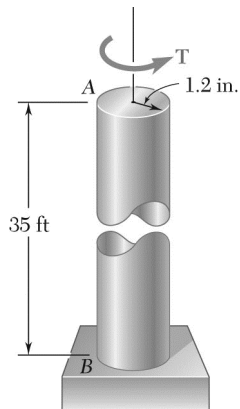

PROBLEM 3.114

The solid circular drill rod AB is made of a steel that is assumed to be elastoplastic with $\tau_Y = 22$ ksi and $G = 11.2 \times 10^6$ psi. Knowing that a torque $T = 75$ kip · in. is applied to the rod and then removed, determine the maximum residual shearing stress in the rod.

SOLUTION

$$c = 1.2 \text{ in.} \quad L = 35 \text{ ft} = 420 \text{ in.}$$

$$J = \frac{\pi}{2}c^4 = \frac{\pi}{2}(1.2)^4 = 3.2572 \text{ in}^4$$

$$T_Y = \frac{J\tau_Y}{c} = \frac{(3.2572)(22)}{1.2} = 59.715 \text{ kip} \cdot \text{in}$$

Loading:

$$T = 75 \text{ kip} \cdot \text{in}$$

$$T = \frac{4}{3}T_Y \left(1 - \frac{1}{4} \frac{\rho_Y^3}{c^3} \right)$$

$$\frac{\rho_Y^3}{c^3} = 4 - \frac{3T}{T_Y} = 4 - \frac{(3)(75)}{59.715} = 0.23213$$

$$\frac{\rho_Y}{c} = 0.61458, \quad \rho_Y = 0.61458c = 0.73749 \text{ in.}$$

Unloading:

$$\tau' = \frac{T\rho}{J} \quad \text{where} \quad T = 75 \text{ kip} \cdot \text{in}$$

At $\rho = c$

$$\tau' = \frac{(75)(1.2)}{3.2572} = 27.63 \text{ ksi}$$

At $\rho = \rho_Y$

$$\tau' = \frac{(75)(0.73749)}{3.2572} = 16.98 \text{ ksi}$$

Residual:

$$\tau_{\text{res}} = \tau_{\text{load}} - \tau'$$

At $\rho = c$

$$\tau_{\text{res}} = 22 - 27.63 = -5.63 \text{ ksi}$$

At $\rho = \rho_Y$

$$\tau_{\text{res}} = 22 - 16.98 = 5.02 \text{ ksi}$$

maximum $\tau_{\text{res}} = 5.63$ ksi ◀

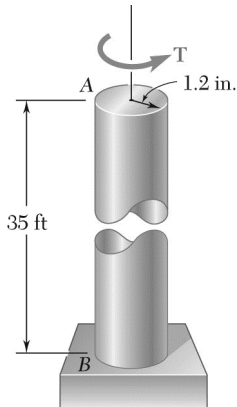

PROBLEM 3.115

In Prob. 3.114, determine the permanent angle of twist of the rod.

PROBLEM 3.114 The solid circular drill rod AB is made of steel that is assumed to be elastoplastic with $\tau_Y = 22$ ksi and $G = 11.2 \times 10^6$ psi. Knowing that a torque $T = 75$ kip · in. is applied to the rod and then removed, determine the maximum residual shearing stress in the rod.

SOLUTION

From the solution to Prob. 3.114,

$$c = 1.2 \text{ in.}$$

$$J = 3.2572 \text{ in}^4$$

$$\frac{\rho_Y}{c} = 0.61458$$

$$\rho_Y = 0.73749 \text{ in.}$$

After loading, $\gamma = \frac{\rho\phi}{L} \quad \therefore \quad \phi = \frac{L\gamma}{\rho} = \frac{L\gamma_Y}{\rho_Y} = \frac{L\tau_Y}{\rho_Y G} \quad L = 35 \text{ ft} = 420 \text{ in.}$

$$\phi_{\text{load}} = \frac{(420)(22 \times 10^3)}{(0.73749)(11.2 \times 10^6)} = 1.11865 \text{ rad} = 64.09^\circ$$

During unloading, $\phi' = \frac{TL}{GJ} \quad (\text{elastic}) \quad T = 5 \times 10^3 \text{ N} \cdot \text{m}$

$$\phi' = \frac{(75 \times 10^3)(420)}{(11.2 \times 10^6)(3.2572)} = 0.86347 \text{ rad} = 49.47^\circ$$

Permanent angle of twist.

$$\phi_{\text{perm}} = \phi_{\text{load}} - \phi' = 1.11865 - 0.86347 = 0.25518 \quad \phi = 14.62^\circ \blacktriangleleft$$

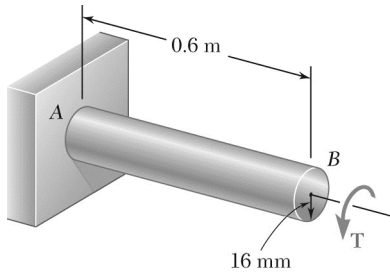

PROBLEM 3.116

The solid shaft shown is made of a steel that is assumed to be elastoplastic with $\tau_Y = 145 \text{ MPa}$ and $G = 77.2 \text{ GPa}$. The torque is increased in magnitude until the shaft has been twisted through 6° ; the torque is then removed. Determine (a) the magnitude and location of the maximum residual shearing stress, (b) the permanent angle of twist.

SOLUTION

$$c = 0.016 \text{ m} \quad \phi = 6^\circ = 104.72 \times 10^{-3} \text{ rad}$$

$$\gamma_{\max} = \frac{c\phi}{L} = \frac{(0.016)(104.72 \times 10^{-3})}{0.6} = 0.0027925$$

$$\gamma_Y = \frac{\tau_Y}{G} = \frac{145 \times 10^6}{77.2 \times 10^9} = 0.0018782$$

$$\frac{\rho_Y}{c} = \frac{\gamma_Y}{\gamma_{\max}} = \frac{0.0018}{0.0027925} = 0.67260$$

$$J = \frac{\pi}{2}c^4 = \frac{\pi}{2}(0.016)^4 = 102.944 \times 10^{-9} \text{ m}^4$$

$$T_Y = \frac{J\tau_Y}{c} = \frac{\pi}{2}c^3\tau_Y = \frac{\pi}{2}(0.016)^3(145 \times 10^6) = 932.93 \text{ N} \cdot \text{m}$$

At end of loading. $T_{\text{load}} = \frac{4}{3}T_Y \left(1 - \frac{1}{4} \frac{\rho_Y^3}{c^3}\right) = \frac{4}{3}(932.93) \left[1 - \frac{1}{4}(0.67433)^3\right] = 1.14855 \times 10^3 \text{ N} \cdot \text{m}$

Unloading: elastic $T' = 1.14855 \times 10^3 \text{ N} \cdot \text{m}$

At $\rho = c$ $\tau' = \frac{T'c}{J} = \frac{(1.14855 \times 10^3)(0.016)}{102.944 \times 10^{-9}} = 178.52 \times 10^6 \text{ Pa}$

At $\rho = \rho_Y$ $\tau' = \frac{T'c}{J} \frac{\rho_Y}{c} = (178.52 \times 10^6)(0.67433) = 120.38 \times 10^6 \text{ Pa}$

$$\phi' = \frac{T'L}{GJ} = \frac{(1.14855 \times 10^3)(0.6)}{(77.2 \times 10^9)(102.944 \times 10^{-9})} = 86.71 \times 10^{-3} \text{ rad} = 4.97^\circ$$

Residual: $\tau_{\text{res}} = \tau_{\text{load}} - \tau' \quad \phi_{\text{perm}} = \phi_{\text{load}} - \phi'$

(a) At $\rho = c$ $\tau_{\text{res}} = 145 \times 10^6 - 178.52 \times 10^6 = -33.52 \times 10^6 \text{ Pa} \quad \tau_{\text{res}} = -33.5 \text{ MPa}$

At $\rho = \rho_Y$ $\tau_{\text{res}} = 145 \times 10^6 - 120.38 \times 10^6 = 24.62 \times 10^6 \text{ Pa} \quad \tau_{\text{res}} = 24.6 \text{ MPa}$

Maximum residual stress: $33.5 \text{ MPa at } \rho = 16 \text{ mm} \blacktriangleleft$

(b) $\phi_{\text{perm}} = 104.72 \times 10^{-3} - 86.71 \times 10^{-3} = 17.78 \times 10^{-3} \text{ rad} \quad \phi_{\text{perm}} = 1.032^\circ \blacktriangleleft$

PROBLEM 3.117

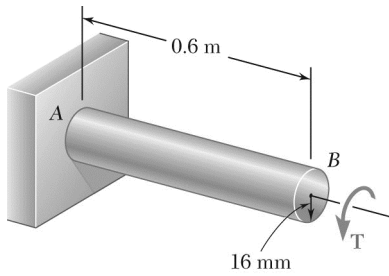

After the solid shaft of Prob. 3.116 has been loaded and unloaded as described in that problem, a torque T_1 of sense opposite to the original torque T is applied to the shaft. Assuming no change in the value of ϕ_Y , determine the angle of twist ϕ_1 for which yield is initiated in this second loading and compare it with the angle ϕ_Y for which the shaft started to yield in the original loading.

PROBLEM 3.116 The solid shaft shown is made of a steel that is assumed to be elastoplastic with $\tau_Y = 145$ MPa and $G = 77.2$ GPa. The torque is increased in magnitude until the shaft has been twisted through 6° ; the torque is then removed. Determine (a) the magnitude and location of the maximum residual shearing stress, (b) the permanent angle of twist.

SOLUTION

From the solution to Prob. 3.116,

$$c = 0.016 \text{ m}, \quad L = 0.6 \text{ m}$$

$$\tau_Y = 145 \times 10^6 \text{ Pa},$$

$$J = 102.944 \times 10^{-9} \text{ m}^4$$

The residual stress at $\rho = c$ is $\tau_{\text{res}} = 33.5$ MPa

For loading in the opposite sense, the change in stress to produce reversed yielding is

$$\tau_1 = \tau_Y - \tau_{\text{res}} = 145 \times 10^6 - 33.5 \times 10^6 = 111.5 \times 10^6 \text{ Pa}$$

$$\begin{aligned} \tau_1 &= \frac{T_1 c}{J} \quad \therefore \quad T_1 = \frac{J \tau_1}{c} = \frac{(102.944 \times 10^{-9})(111.5 \times 10^6)}{0.016} \\ &= 717 \text{ N} \cdot \text{m} \end{aligned}$$

Angle of twist at yielding under reversed torque.

$$\phi_1 = \frac{T_1 L}{GJ} = \frac{(717 \times 10^3)(0.6)}{(77.2 \times 10^9)(102.944 \times 10^{-9})} = 54.16 \times 10^{-3} \text{ rad} \quad \phi_1 = 3.10^\circ \blacktriangleleft$$

Angle of twist for yielding in original loading.

$$\begin{aligned} \gamma &= \frac{\tau_Y}{G} = \frac{c \phi_Y}{L} \\ \phi_Y &= \frac{L \tau_Y}{cG} = \frac{(0.6)(145 \times 10^6)}{(0.016)(77.2 \times 10^9)} = 70.434 \times 10^{-3} \text{ rad} \quad \phi_Y = 4.04^\circ \blacktriangleleft \end{aligned}$$

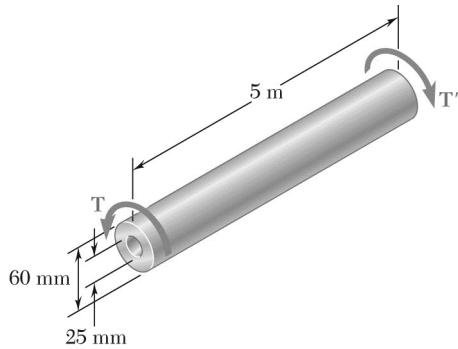

PROBLEM 3.118

The hollow shaft shown is made of a steel that is assumed to be elastoplastic with $\tau_Y = 145 \text{ MPa}$ and $G = 77.2 \text{ GPa}$. The magnitude T of the torques is slowly increased until the plastic zone first reaches the inner surface of the shaft; the torques are then removed. Determine the magnitude and location of the maximum residual shearing stress in the rod.

SOLUTION

$$c_1 = \frac{1}{2}d_1 = 12.5 \text{ mm}$$

$$c_2 = \frac{1}{2}d_2 = 30 \text{ mm}$$

When the plastic zone reaches the inner surface, the stress is equal to τ_Y . The corresponding torque is calculated by integration.

$$dT = \rho\tau \, dA = \rho\tau_Y(2\pi\rho \, d\rho) = 2\pi\tau_Y\rho^2 \, d\rho$$

$$T = 2\pi\tau_Y \int_{c_1}^{c_2} \rho^2 \, d\rho = \frac{2\pi}{3}\tau_Y(c_2^3 - c_1^3)$$

$$= \frac{2\pi}{3}(145 \times 10^6)[(30 \times 10^{-3})^3 - (12.5 \times 10^{-3})^3] = 7.6064 \times 10^3 \text{ N} \cdot \text{m}$$

Unloading.

$$T' = 7.6064 \times 10^3 \text{ N} \cdot \text{m}$$

$$J = \frac{\pi}{2}(c_2^4 - c_1^4) = \frac{\pi}{2}[(30)^4 - (12.5)^4] = 1.234 \times 10^6 \text{ mm}^4 = 1.234 \times 10^{-6} \text{ m}^4$$

$$\tau'_1 = \frac{T'c_1}{J} = \frac{(7.6064 \times 10^3)(12.5 \times 10^{-3})}{1.234 \times 10^{-6}} = 77.050 \times 10^6 \text{ Pa} = 77.05 \text{ MPa}$$

$$\tau'_2 = \frac{T'c_2}{J} = \frac{(7.6064 \times 10^3)(30 \times 10^{-3})}{1.234 \times 10^{-6}} = 192.63 \times 10^6 \text{ Pa} = 192.63 \text{ MPa}$$

Residual stress.

Inner surface: $\tau_{\text{res}} = \tau_Y - \tau'_1 = 145 - 77.05 = 67.95 \text{ MPa}$

Outer surface: $\tau_{\text{res}} = \tau_Y - \tau'_2 = 145 - 192.63 = -47.63 \text{ MPa}$

Maximum residual stress:

68.0 MPa at inner surface. ◀

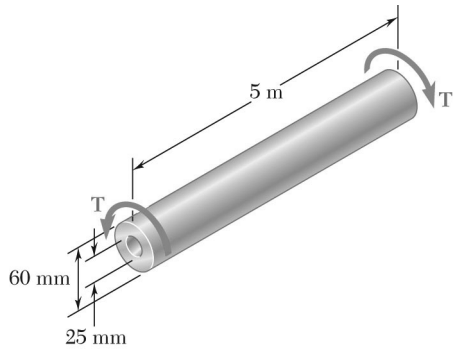

PROBLEM 3.119

In Prob. 3.118, determine the permanent angle of twist of the rod.

PROBLEM 3.118 The hollow shaft shown is made of a steel that is assumed to be elastoplastic with $\tau_Y = 145$ MPa and $G = 77.2$ GPa. The magnitude T of the torques is slowly increased until the plastic zone first reaches the inner surface of the shaft; the torques are then removed. Determine the magnitude and location of the maximum residual shearing stress in the rod.

SOLUTION

$$c_1 = \frac{1}{2}d_1 = 12.5 \text{ mm}$$

$$c_2 = \frac{1}{2}d_2 = 30 \text{ mm}$$

When the plastic zone reaches the inner surface, the stress is equal to τ_Y . The corresponding torque is calculated by integration.

$$\begin{aligned} dT &= \rho\tau \, dA = \rho\tau_Y (2\pi\rho d\rho) = 2\pi\tau_Y \rho^2 d\rho \\ T &= 2\pi\tau_Y \int_{c_1}^{c_2} \rho^2 d\rho = \frac{2\pi}{3}\tau_Y (c_2^3 - c_1^3) \\ &= \frac{2\pi}{3}(145 \times 10^6)[(30 \times 10^{-3})^3 - (12.5 \times 10^{-3})^3] = 7.6064 \times 10^3 \text{ N} \cdot \text{m} \end{aligned}$$

Rotation angle at maximum torque.

$$\begin{aligned} \frac{c_1\phi_{\max}}{L} &= \gamma_Y = \frac{\tau_Y}{G} \\ \phi_{\max} &= \frac{\tau_Y L}{Gc_1} = \frac{(145 \times 10^6)(5)}{(77.2 \times 10^9)(12.5 \times 10^{-3})} = 0.75130 \text{ rad} \end{aligned}$$

Unloading. $T' = 7.6064 \times 10^3 \text{ N} \cdot \text{m}$

$$\begin{aligned} J &= \frac{\pi}{2}(c_2^4 - c_1^4) = \frac{\pi}{2}[(30)^4 - (12.5)^4] = 1.234 \times 10^6 \text{ mm}^4 = 1.234 \times 10^{-6} \text{ m}^4 \\ \phi' &= \frac{T'L}{GJ} = \frac{(7.6064 \times 10^3)(5)}{(77.2 \times 10^9)(1.234 \times 10^{-6})} = 0.39922 \text{ rad} \end{aligned}$$

Permanent angle of twist.

$$\phi_{\text{perm}} = \phi_{\max} - \phi' = 0.75130 - 0.39922 = 0.35208 \text{ rad} \quad \phi_{\text{perm}} = 20.2^\circ \blacktriangleleft$$

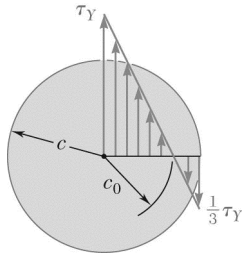

PROBLEM 3.120

A torque T applied to a solid rod made of an elastoplastic material is increased until the rod is fully plastic and then removed. (a) Show that the distribution of residual shearing stresses is as represented in the figure. (b) Determine the magnitude of the torque due to the stresses acting on the portion of the rod located within a circle of radius c_0 .

SOLUTION

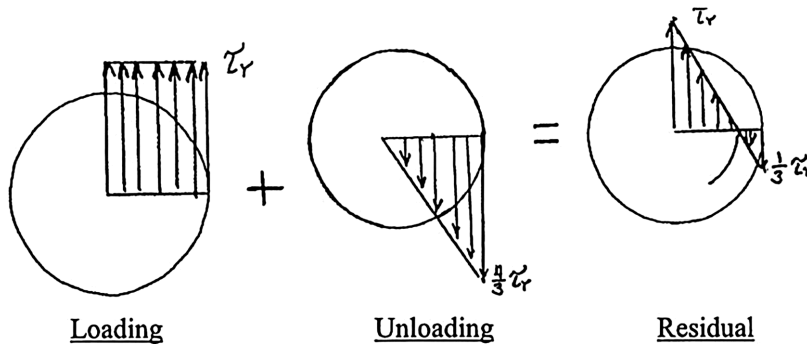

(a)

After loading: $\rho_Y = 0, \quad T_{\text{load}} = \frac{4}{3}T_Y = \frac{4}{3} \frac{\pi}{2} c^3 \tau_Y = \frac{2\pi}{3} c^3 \tau_Y$

Unloading: $\tau' = \frac{Tc}{J} = \frac{2T}{\pi c^3} = \frac{2(T_{\text{load}})}{\pi c^3} = \frac{4}{3} \tau_Y \quad \text{at } \rho = c$
 $\tau' = \frac{4}{3} \tau_Y \frac{\rho}{c}$

Residual: $\tau_{\text{res}} = \tau_Y - \frac{4}{3} \tau_Y \frac{\rho}{c} = \tau_Y \left(1 - \frac{4\rho}{3c}\right)$

To find c_0 set, $\tau_{\text{res}} = 0 \quad \text{and} \quad \rho = c_0$

$$0 = 1 - \frac{4c_0}{3c} \quad \therefore \quad c_0 = \frac{3}{4}c \quad c_0 = 0.150c \quad \blacktriangleleft$$

(b) $T_0 = 2\pi \int_0^{c_0} \rho^2 \tau d\rho = 2\pi \int_0^{(3/4)c} \rho^2 \tau_Y \left(1 - \frac{4\rho}{3c}\right) d\rho$
 $= 2\pi \tau_Y \left(\frac{\rho^3}{3} - \frac{4\rho^4}{3 \cdot 4c} \right) \Big|_0^{(3/4)c} = 2\pi \tau_Y c^3 \left\{ \frac{1}{3} \left(\frac{3}{4}\right)^3 - \left(\frac{4}{3}\right) \frac{1}{4} \left(\frac{3}{4}\right)^4 \right\}$
 $= 2\pi \tau_Y c^3 \left\{ \frac{9}{64} - \frac{27}{256} \right\} = \frac{9\pi}{128} \tau_Y c^3 = 0.2209 \tau_Y c^3 \quad T_0 = 0.221 \tau_Y c^3 \quad \blacktriangleleft$

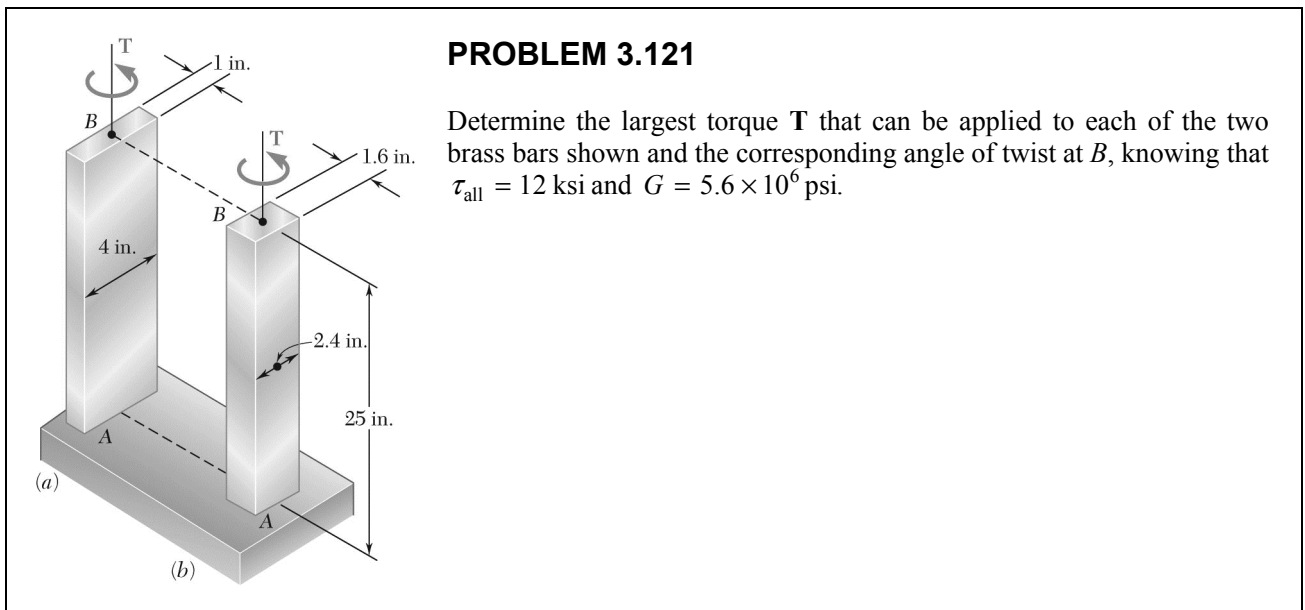

PROBLEM 3.121

Determine the largest torque T that can be applied to each of the two brass bars shown and the corresponding angle of twist at B , knowing that $\tau_{\text{all}} = 12 \text{ ksi}$ and $G = 5.6 \times 10^6 \text{ psi}$.

SOLUTION

$$L = 25 \text{ in.}, \quad G = 5.6 \times 10^6 \text{ psi}, \quad \tau_{\text{all}} = 12 \times 10^3 \text{ psi}$$

$$\tau_{\text{max}} = \frac{T}{c_1 ab^2} \quad \text{or} \quad T = c_1 ab^2 \tau_{\text{max}} \quad (1)$$

$$\phi = \frac{TL}{c_2 ab^3 G} \quad \text{or} \quad \phi = \frac{c_1 L \tau_{\text{max}}}{c_2 b G} \quad (2)$$

(a) $a = 4 \text{ in.}, \quad b = 1 \text{ in.}, \quad \frac{a}{b} = 4.0$ From Table 3.1: $c_1 = 0.282, \quad c_2 = 0.281$

From (1): $T = (0.282)(4)(1)^2(12 \times 10^3) = 13.54 \times 10^3$ $T = 13.54 \text{ kip} \cdot \text{in} \quad \blacktriangleleft$

From (2): $\phi = \frac{(0.282)(25)(12 \times 10^3)}{(0.281)(1)(5.6 \times 10^6)} = 0.05376 \text{ radians}$ $\phi = 3.08^\circ \quad \blacktriangleleft$

(b) $a = 2.4 \text{ in.}, \quad b = 1.6 \text{ in.}, \quad \frac{a}{b} = 1.5$ From Table 3.1: $c_1 = 0.231, \quad c_2 = 0.1958$

From (1): $T = (0.231)(2.4)(1.6)^2(12 \times 10^3) = 17.03 \times 10^3$ $T = 17.03 \text{ kip} \cdot \text{in} \quad \blacktriangleleft$

From (2): $\phi = \frac{(0.231)(25)(12 \times 10^3)}{(0.1958)(1.6)(5.6 \times 10^6)} = 0.0395 \text{ radians}$ $\phi = 2.26^\circ \quad \blacktriangleleft$

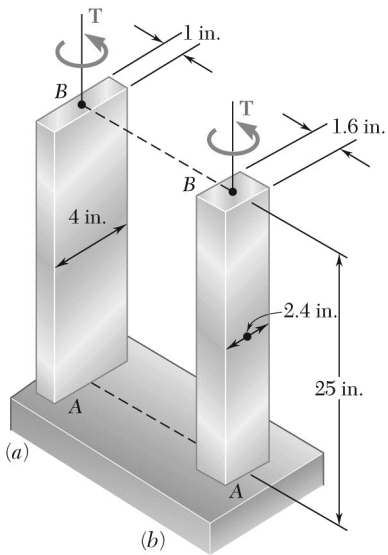

PROBLEM 3.122

Each of the two brass bars shown is subjected to a torque of magnitude $T = 12.5 \text{ kip} \cdot \text{in}$. Knowing that $G = 5.6 \times 10^6 \text{ psi}$, determine for each bar the maximum shearing stress and the angle of twist at B .

SOLUTION

$$L = 25 \text{ in.}, \quad G = 5.6 \times 10^6 \text{ psi}, \quad T = 12.5 \times 10^3 \text{ lb} \cdot \text{in}$$

$$(a) \quad a = 4 \text{ in.}, \quad b = 1 \text{ in.}, \quad \frac{a}{b} = 4.0$$

$$\text{From Table 3.1:} \quad c_1 = 0.282, \quad c_2 = 0.281$$

$$\tau_{\max} = \frac{T}{c_1 a b^2} = \frac{12.5 \times 10^3}{(0.282)(4)(1)^2} = 11.08 \times 10^3 \quad \tau_{\max} = 11.08 \text{ ksi} \quad \blacktriangleleft$$

$$\varphi = \frac{TL}{c_2 a b^3 G} = \frac{(12.5 \times 10^3)(25)}{(0.282)(4)(1)^3 (5.6 \times 10^6)} = 0.04965 \text{ radians}$$

$$\varphi = 2.84^\circ \quad \blacktriangleleft$$

$$(b) \quad a = 2.4 \text{ in.}, \quad b = 1.6 \text{ in.}, \quad \frac{a}{b} = 1.5$$

$$\text{From Table 3.1:} \quad c_1 = 0.231, \quad c_2 = 0.1958$$

$$\tau_{\max} = \frac{T}{c_1 a b^2} = \frac{12.5 \times 10^3}{(0.231)(2.4)(1.6)^2} = 8.81 \times 10^3 \quad \tau_{\max} = 8.81 \text{ ksi} \quad \blacktriangleleft$$

$$\varphi = \frac{TL}{c_2 a b^3 G} = \frac{(12.5 \times 10^3)(25)}{(0.1958)(2.4)(1.6)^3 (5.6 \times 10^6)} = 0.02899 \text{ radians}$$

$$\varphi = 1.661^\circ \quad \blacktriangleleft$$

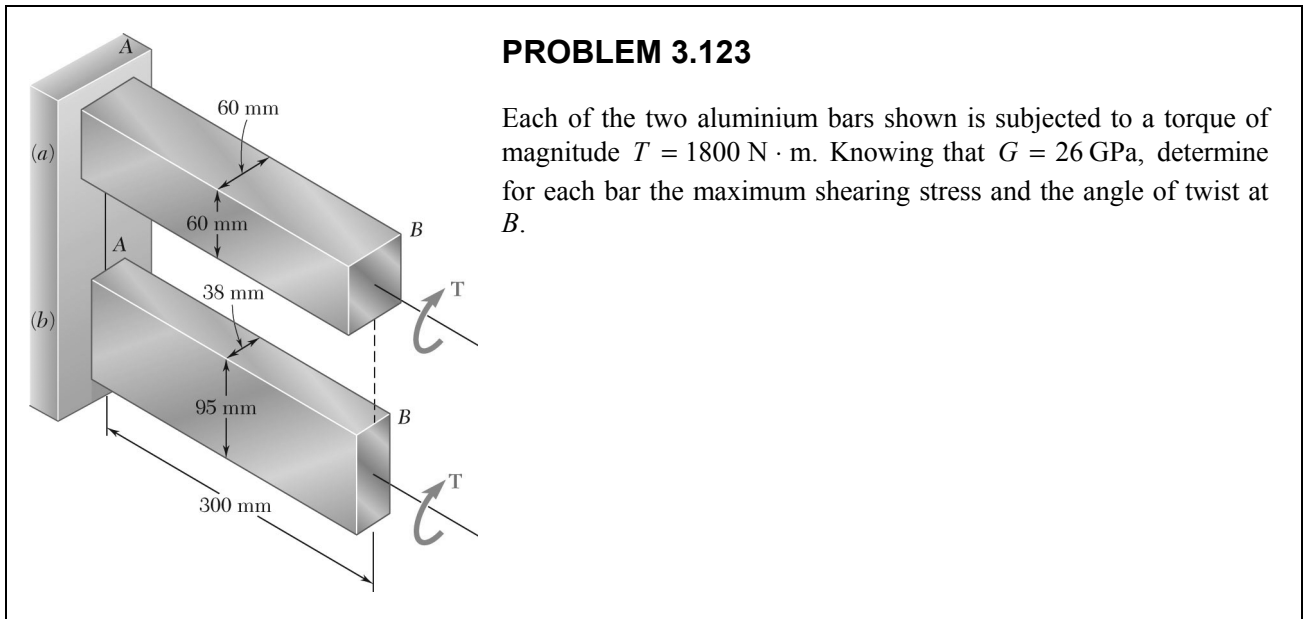

PROBLEM 3.123

Each of the two aluminium bars shown is subjected to a torque of magnitude $T = 1800 \text{ N} \cdot \text{m}$. Knowing that $G = 26 \text{ GPa}$, determine for each bar the maximum shearing stress and the angle of twist at B .

SOLUTION

$$T = 1800 \text{ N} \cdot \text{m} \quad L = 0.300 \text{ m} \quad G = 26 \times 10^9 \text{ Pa}$$

$$(a) \quad a = b = 60 \text{ mm} = 0.060 \text{ m} \quad \frac{a}{b} = 1.0$$

$$\text{From Table 3.1:} \quad c_1 = 0.208, \quad c_2 = 0.1406$$

$$\tau_{\max} = \frac{T}{c_1 a b^2} = \frac{1800}{(0.208)(0.060)(0.060)^2} = 40.1 \times 10^6 \text{ Pa} \quad \tau_{\max} = 40.1 \text{ MPa} \quad \blacktriangleleft$$

$$\varphi = \frac{TL}{c_2 a b^3 G} = \frac{(1800)(0.300)}{(0.1406)(0.060)(0.060)^3 (26 \times 10^9)} = 0.011398 \text{ radians} \quad \varphi = 0.653^\circ \quad \blacktriangleleft$$

$$(b) \quad a = 95 \text{ mm} = 0.095 \text{ m}, \quad b = 38 \text{ mm} = 0.038 \text{ m}, \quad \frac{a}{b} = 2.5$$

$$\text{From Table 3.1:} \quad c_1 = 0.258, \quad c_2 = 0.249$$

$$\tau_{\max} = \frac{T}{c_1 a b^2} = \frac{1800}{(0.258)(0.095)(0.038)^2} = 50.9 \times 10^6 \text{ Pa} \quad \tau_{\max} = 50.9 \text{ MPa} \quad \blacktriangleleft$$

$$\varphi = \frac{TL}{c_2 a b^3 G} = \frac{(1800)(0.300)}{(0.249)(0.095)(0.038)^3 (26 \times 10^9)} = 0.01600 \text{ radians} \quad \varphi = 0.917^\circ \quad \blacktriangleleft$$

PROBLEM 3.124

Determine the largest torque T that can be applied to each of the two aluminium bars shown and the corresponding angle of twist at B , knowing $\tau_{\text{all}} = 50 \text{ MPa}$ and $G = 26 \text{ GPa}$.

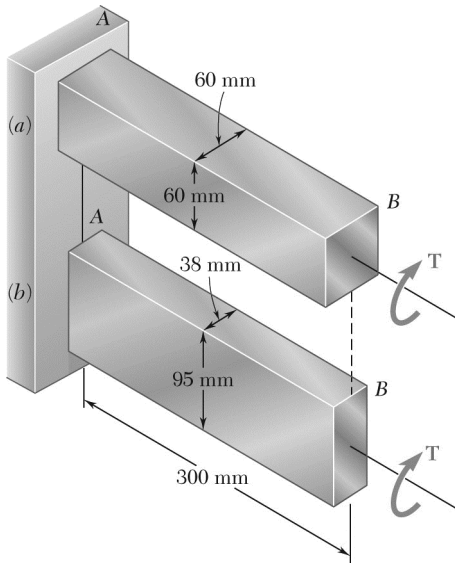

SOLUTION

$$L = 0.300 \text{ m}, \quad G = 26 \times 10^9 \text{ Pa}, \quad \tau_{\text{all}} = 50 \times 10^6 \text{ Pa}$$

$$\tau_{\text{max}} = \frac{T}{c_1 ab^2} \quad \text{or} \quad T = c_1 ab^2 \tau_{\text{max}} \quad (1)$$

$$\varphi = \frac{TL}{c_2 ab^4 G} \quad \text{or} \quad \varphi = \frac{c_1 L \tau_{\text{max}}}{c_2 b G} \quad (2)$$

$$(a) \quad a = b = 60 \text{ mm} = 0.060 \text{ m}, \quad \frac{a}{b} = 1.0$$

$$\text{From Table 3.1:} \quad c_1 = 0.208, \quad c_2 = 0.1406$$

$$\text{From (1):} \quad T = (0.208)(0.060)(0.060)^2(50 \times 10^6) = 2246 \text{ N} \cdot \text{m} \quad T = 2.25 \text{ kN} \cdot \text{m} \quad \blacktriangleleft$$

$$\text{From (2):} \quad \varphi = \frac{(0.208)(0.300)(50 \times 10^6)}{(0.1406)(0.060)(26 \times 10^9)} = 0.01422 \text{ radians} \quad \varphi = 0.815^\circ \quad \blacktriangleleft$$

$$(b) \quad a = 95 \text{ mm} = 0.095 \text{ m}, \quad b = 38 \text{ mm} = 0.038 \text{ m}, \quad \frac{a}{b} = 2.5$$

$$\text{From Table 3.1:} \quad c_1 = 0.258, \quad c_2 = 0.249$$

$$\text{From (1):} \quad T = (0.258)(0.095)(0.038)^2(50 \times 10^6) = 1770 \text{ N} \cdot \text{m} \quad T = 1.770 \text{ kN} \cdot \text{m} \quad \blacktriangleleft$$

$$\text{From (2):} \quad \varphi = \frac{(0.258)(0.300)(50 \times 10^6)}{(0.249)(0.038)(26 \times 10^9)} = 0.01573 \text{ radians} \quad \varphi = 0.901^\circ \quad \blacktriangleleft$$

PROBLEM 3.125

Determine the largest allowable square cross section of a steel shaft of length 20 ft if the maximum shearing stress is not to exceed 10 ksi when the shaft is twisted through one complete revolution. Use $G = 11.2 \times 10^6$ psi.

SOLUTION

$$L = 20 \text{ ft} = 240 \text{ in.}$$

$$\tau_{\max} = 10 \text{ ksi} = 10 \times 10^3 \text{ psi}$$

$$\varphi = 1 \text{ rev} = 2\pi \text{ radians}$$

$$\tau_{\max} = \frac{T}{c_1 a b^2} \quad (1)$$

$$\varphi = \frac{TL}{c_2 a b^3 G} \quad (2)$$

Divide (2) by (1) to eliminate T .

$$\frac{\varphi}{\tau_{\max}} = \frac{c_1 a b^2 L}{c_2 a b^3 G} = \frac{c_1 L}{c_2 b G}$$

Solve for b .

$$b = \frac{c_1 L \tau_{\max}}{c_2 G \varphi}$$

For a square section,

$$\frac{a}{b} = 1.0$$

From Table 3.1,

$$c_1 = 0.208,$$

$$c_2 = 0.1406$$

$$b = \frac{(0.208)(240)(10 \times 10^3)}{(0.1406)(11.2 \times 10^6)(2\pi)} \quad b = 0.0505 \text{ in.} \blacktriangleleft$$

PROBLEM 3.126

Determine the largest allowable length of a stainless steel shaft of $\frac{3}{8} \times \frac{3}{4}$ -in. cross section if the shearing stress is not to exceed 15 ksi when the shaft is twisted through 15° . Use $G = 11.2 \times 10^6$ psi.

SOLUTION

$$a = \frac{3}{4} \text{ in.} = 0.75 \text{ in.}$$

$$b = \frac{3}{8} \text{ in.} = 0.375 \text{ in.}$$

$$\tau_{\max} = 15 \text{ ksi} = 15 \times 10^3 \text{ psi}$$

$$\phi = 15^\circ = \frac{15\pi}{180} \text{ rad} = 0.26180 \text{ rad}$$

$$\tau_{\max} = \frac{T}{c_1 a b^2} \quad (1)$$

$$\phi = \frac{TL}{c_2 a b^3 G} \quad (2)$$

Divide (2) by (1) to eliminate T .

$$\frac{\phi}{\tau_{\max}} = \frac{c_1 a b^2 L}{c_2 a b^3 G} = \frac{c_1 L}{c_2 b G}$$

Solve for L .

$$L = \frac{c_2 b G \phi}{c_1 \tau_{\max}}$$

$$\frac{a}{b} = \frac{0.75}{0.375} = 2$$

Table 3.1 gives $c_1 = 0.246$, $c_2 = 0.229$

$$L = \frac{(0.229)(0.375)(11.2 \times 10^6)(0.26180)}{(0.246)(15 \times 10^3)} = 68.2 \text{ in.} \quad L = 68.2 \text{ in.} \blacktriangleleft$$

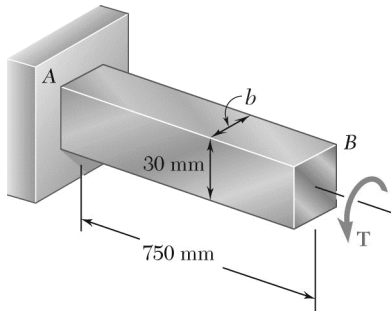

PROBLEM 3.127

The torque T causes a rotation of 2° at end B of the stainless steel bar shown. Knowing that $b = 20\text{ mm}$ and $G = 75\text{ GPa}$, determine the maximum shearing stress in the bar.

SOLUTION

$$a = 30\text{ mm} = 0.030\text{ m}$$

$$b = 20\text{ mm} = 0.020\text{ m}$$

$$\varphi = 2^\circ = 34.907 \times 10^{-3}\text{ rad}$$

$$\varphi = \frac{TL}{c_2 ab^3 G} \quad \therefore T = \frac{c_2 ab^3 G \varphi}{L}$$

$$\tau_{\max} = \frac{T}{c_1 ab^2} = \frac{c_2 ab^3 G \varphi}{c_1 ab^2 L} = \frac{c_2 b G \varphi}{c_1 L}$$

$$\frac{a}{b} = \frac{30}{20} = 1.5.$$

From Table 3.1,

$$c_1 = 0.231$$

$$c_2 = 0.1958$$

$$\tau_{\max} = \frac{(0.1958)(20 \times 10^{-3})(75 \times 10^9)(34.907 \times 10^{-3})}{(0.231)(750 \times 10^{-3})} = 59.2 \times 10^6\text{ Pa}$$

$$\tau_{\max} = 59.2\text{ MPa} \quad \blacktriangleleft$$

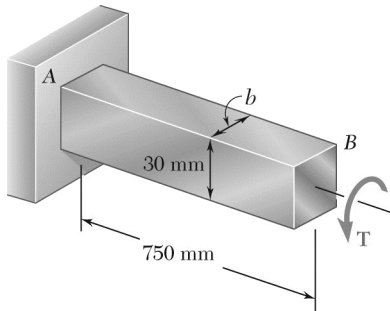

PROBLEM 3.128

The torque T causes a rotation of 0.6° at end B of the aluminum bar shown. Knowing that $b = 15 \text{ mm}$ and $G = 26 \text{ GPa}$, determine the maximum shearing stress in the bar.

SOLUTION

$$a = 30 \text{ mm} = 0.030 \text{ m}$$

$$b = 15 \text{ mm} = 0.015 \text{ m}$$

$$\varphi = 0.6^\circ = 10.472 \times 10^{-3} \text{ rad}$$

$$\varphi = \frac{TL}{c_2 ab^3 G} \quad \therefore \quad T = \frac{c_2 ab^3 G \varphi}{c_1 L}$$

$$\tau_{\max} = \frac{T}{c_1 ab^2} = \frac{c_2 ab^3 G \varphi}{c_1 ab^2 L} = \frac{c_2 b G \varphi}{c_1 L}$$

$$\frac{a}{b} = \frac{30}{15} = 2.0$$

From Table 3.1,

$$c_1 = 0.246$$

$$c_2 = 0.229$$

$$\tau_{\max} = \frac{(0.229)(15 \times 10^{-3})(26 \times 10^9)(10.472 \times 10^{-3})}{(0.246)(750 \times 10^{-3})}$$

$$= 5.07 \times 10^6 \text{ Pa}$$

$$\tau_{\max} = 5.07 \text{ MPa} \quad \blacktriangleleft$$

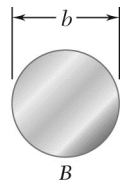
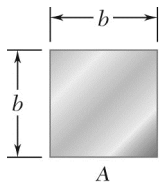

PROBLEM 3.129

Two shafts are made of the same material. The cross section of shaft A is a square of side b and that of shaft B is a circle of diameter b . Knowing that the shafts are subjected to the same torque, determine the ratio τ_A/τ_B of maximum shearing stresses occurring in the shafts.

SOLUTION

A. Square: $\frac{a}{b} = 1, \quad c_1 = 0.208 \quad (\text{Table 3.1})$

$$\tau_A = \frac{T}{c_1 a b^2} = \frac{T}{0.208 b^3}$$

B. Circle: $c = \frac{1}{2}b \quad \tau_B = \frac{Tc}{J} = \frac{2T}{\pi c^3} = \frac{16T}{\pi b^3}$

Ratio: $\frac{\tau_A}{\tau_B} = \frac{1}{0.208} \cdot \frac{\pi}{16} = 0.3005\pi \qquad \frac{\tau_A}{\tau_B} = 0.944 \blacktriangleleft$

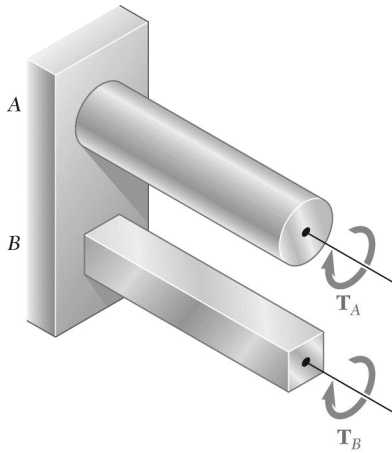

PROBLEM 3.130

Shafts A and B are made of the same material and have the same cross-sectional area, but A has a circular cross section and B has a square cross section. Determine the ratio of the maximum shearing stresses occurring in A and B , respectively, when the two shafts are subjected to the same torque ($T_A = T_B$). Assume both deformations to be elastic.

SOLUTION

Let c be the radius of circular section A and b be the side square section B .

For equal areas, $\pi c^2 = b^2 \quad b = c\sqrt{\pi}$

Circle: $\tau_A = \frac{T_{AC}}{J} = \frac{2T_A}{\pi c^3}$

Square: $\frac{a}{b} = 1 \quad c_1 = 0.208 \quad \text{from Table 3.1}$

$$\tau_B = \frac{T_B}{c_1 a b^2} = \frac{T_B}{c_1 b^3}$$

Ratio: $\frac{\tau_A}{\tau_B} = \frac{2T_A}{\pi c^3} \frac{c_1 b^3}{T_B} = \frac{2c_1 b^3}{\pi c^3} \frac{T_A}{T_B} = 2c_1 \sqrt{\pi} \frac{T_A}{T_B}$

For $T_A = T_B$, $\frac{\tau_A}{\tau_B} = (2)(0.208)\sqrt{\pi} \quad \frac{\tau_A}{\tau_B} = 0.737 \blacktriangleleft$

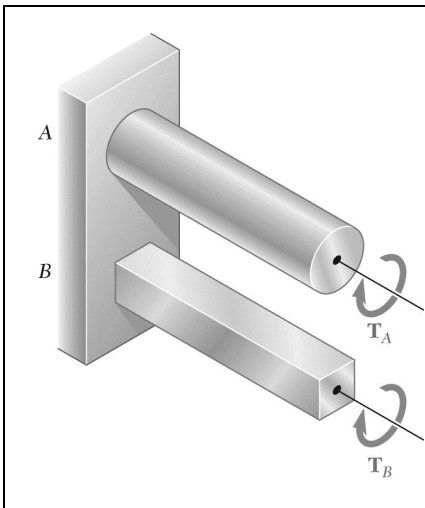

PROBLEM 3.131

Shafts A and B are made of the same material and have the same cross-sectional area, but A has a circular cross section and B has a square cross section. Determine the ratio of the maximum torques T_A and T_B that can be safely applied to A and B , respectively.

SOLUTION

Let c = radius of circular section A and b = side of square section B .

For equal areas $\pi c^2 = b^2$,

$$c = \frac{b}{\sqrt{\pi}}$$

Circle:

$$\tau_A = \frac{T_A c}{J} = \frac{2T_A}{\pi c^3} \quad \therefore \quad T_A = \frac{\pi}{2} c^3 \tau_A$$

Square:

From Table 3.1,

$$c_1 = 0.208$$

$$\tau_B = \frac{T_B}{c_1 a b^2} = \frac{T_B}{c_1 b^3} \quad \therefore \quad T_B = c_1 b^3 \tau_B$$

Ratio:

$$\frac{T_A}{T_B} = \frac{\frac{\pi}{2} c^3 \tau_B}{c_1 b^3 \tau_B} = \frac{\frac{\pi}{2} \cdot \frac{b^3}{\pi^{3/2}} \tau_B}{c_1 b^3 \tau_B} = \frac{1}{2c_1 \sqrt{\pi}} \frac{\tau_A}{\tau_B}$$

For the same stresses,

$$\tau_B = \tau_A \quad \therefore \quad \frac{T_A}{T_B} = \frac{1}{(2)(0.208)\sqrt{\pi}}$$

$$\frac{T_A}{T_B} = 1.356 \quad \blacktriangleleft$$

PROBLEM 3.132

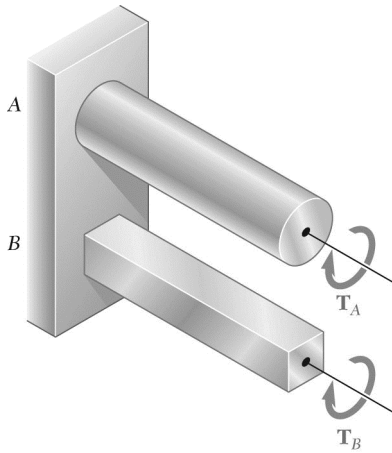

Shafts A and B are made of the same material and have the same length and cross-sectional area, but A has a circular cross section and B has a square cross section. Determine the ratio of the maximum values of the angles φ_A and φ_B through which shafts A and B , respectively, can be twisted.

SOLUTION

Let c = radius of circular section A and b = side of square section B .

For equal areas, $\pi c^2 = b^2 \quad \therefore \quad b = \sqrt{\pi c}$

Circle: $\gamma_{\max} = \frac{\tau_A}{G} = \frac{c\varphi_A}{L} \quad \therefore \quad \varphi_A = \frac{L\tau_A}{cG}$

Square: From Table 3.1, $c_1 = 0.208, \quad c_2 = 0.1406$

$$\tau_B = \frac{T_B}{c_1 ab^2} = \frac{T_B}{0.208 b^3} \quad \therefore \quad T_B = 0.208 b^3 \tau_B$$

$$\varphi_B = \frac{T_B L}{c_2 ab^3 G} = \frac{0.208 b^3 \tau_B L}{0.1406 b^4 G} = \frac{1.4794 L \tau_B}{bG}$$

Ratio: $\frac{\varphi_A}{\varphi_B} = \frac{L\tau_A}{cG} \cdot \frac{bG}{1.4794 L \tau_B} = 0.676 \frac{b\tau_A}{c\tau_B} = 0.676 \sqrt{\pi} \frac{\tau_A}{\tau_B}$

For equal stresses, $\tau_A = \tau_B \quad \frac{\varphi_B}{\varphi_A} = 0.676 \sqrt{\pi} \quad \frac{\varphi_B}{\varphi_A} = 1.198 \blacktriangleleft$

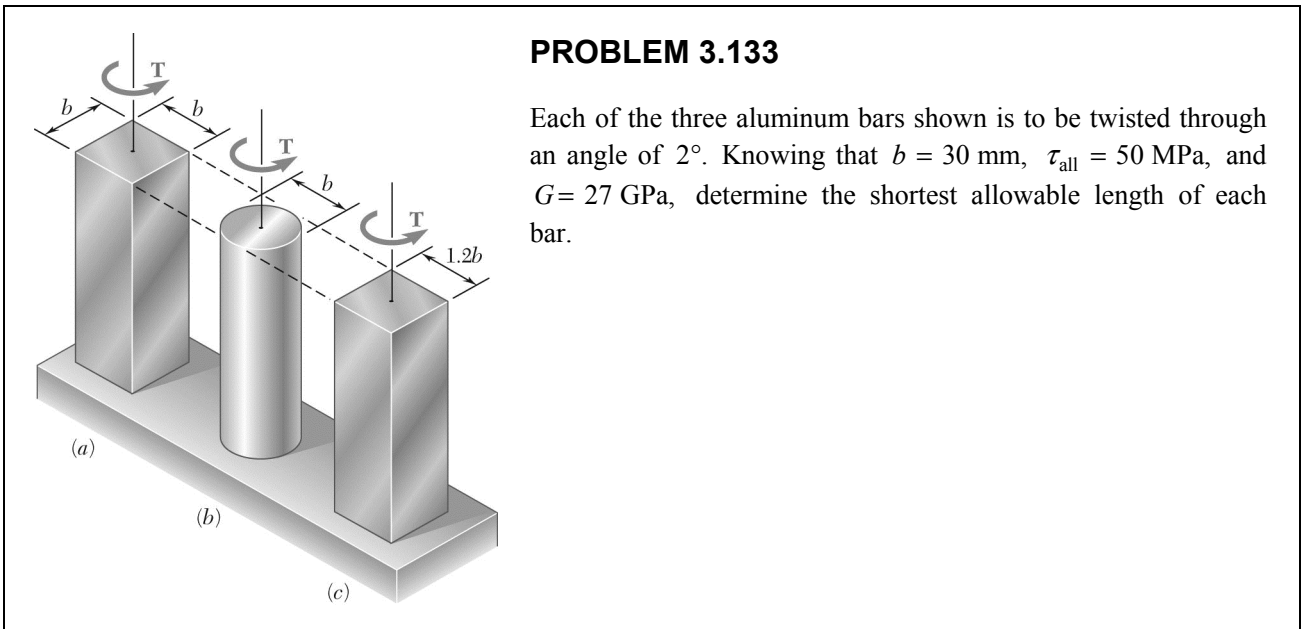

SOLUTION

$$\varphi = 2^\circ = 34.907 \times 10^{-3} \text{ rad}, \quad \tau = 50 \times 10^6 \text{ Pa} \quad G = 27 \times 10^9 \text{ Pa}, \quad b = 30 \text{ mm} = 0.030 \text{ m}$$

For square and rectangle, $\tau = \frac{T}{c_1 ab^2} \quad \varphi = \frac{TL}{c_2 ab^3 G}$

Divide to eliminate T ; then solve for L . $\frac{\varphi}{\tau} = \frac{c_1 ab^2 L}{c_2 ab^3 G} \quad L = \frac{c_2 b G \varphi}{c_1 \tau}$

(a) Square: $\frac{a}{b} = 1.0$ From Table 3.1, $c_1 = 0.208$, $c_2 = 0.1406$

$$L = \frac{(0.1406)(0.030)(27 \times 10^9)(34.907 \times 10^{-3})}{(0.208)(50 \times 10^6)} = 382 \times 10^{-3} \text{ m} \quad L = 382 \text{ mm} \blacktriangleleft$$

(b) Circle: $c = \frac{1}{2}b = 0.015 \text{ m} \quad \tau = \frac{Tc}{J} \quad \varphi = \frac{TL}{GJ}$

Divide to eliminate T ; then solve for L . $\frac{\varphi}{\tau} = \frac{JL}{cGJ} = \frac{L}{cG}$

$$L = \frac{cG\varphi}{\tau} = \frac{(0.015)(27 \times 10^9)(34.907 \times 10^{-3})}{50 \times 10^6} = 283 \times 10^{-3} \text{ m} \quad L = 283 \text{ mm} \blacktriangleleft$$

(c) Rectangle: $a = 1.2b \quad \frac{a}{b} = 1.2$ From Table 3.1, $c_1 = 0.219$, $c_2 = 0.1661$

$$L = \frac{(0.1661)(0.030)(27 \times 10^9)(34.907 \times 10^{-3})}{(0.219)(50 \times 10^6)} = 429 \times 10^{-3} \text{ m} \quad L = 429 \text{ mm} \blacktriangleleft$$

PROBLEM 3.134

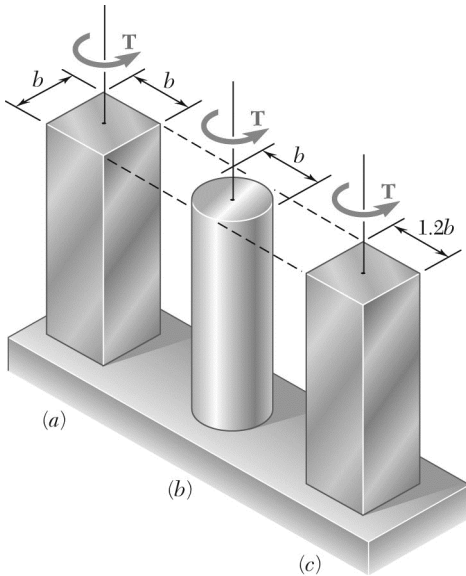

Each of the three steel bars is subjected to a torque as shown. Knowing that the allowable shearing stress is 8 ksi and that $b = 1.4$ in., determine the maximum torque T that can be applied to each bar.

SOLUTION

$$\tau_{\max} = 8 \text{ ksi}, \quad b = 1.4 \text{ in.}$$

(a) Square: $a = b = 1.4 \text{ in.} \quad \frac{a}{b} = 1.0$

From Table 3.1, $c_1 = 0.208$

$$\tau_{\max} = \frac{T}{c_1 a b^2} \quad T = c_1 a b^2 \tau_{\max}$$

$$T = (0.208)(1.4)(1.4)(1.4)^2(8) \quad T = 4.57 \text{ kip} \cdot \text{in} \quad \blacktriangleleft$$

(b) Circle: $c = \frac{1}{2}b = 0.7 \text{ in.}$

$$\tau_{\max} = \frac{Tc}{J} = \frac{2T}{\pi c^3} \quad T = \frac{\pi}{2} c^3 \tau_{\max}$$

$$T = \frac{\pi}{2} (0.7)^3 (8) \quad T = 4.31 \text{ kip} \cdot \text{in} \quad \blacktriangleleft$$

(c) Rectangle: $a = (1.2)(1.4) = 1.68 \text{ in.} \quad \frac{a}{b} = 1.2$

From Table 3.1, $c_1 = 0.219$

$$T = c_1 a b^2 \tau_{\max} = (0.219)(1.68)(1.4)^2(8) \quad T = 5.77 \text{ kip} \cdot \text{in} \quad \blacktriangleleft$$

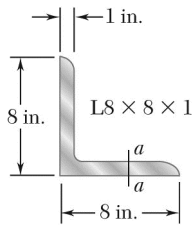

PROBLEM 3.135

A 36-kip · in. torque is applied to a 10-ft-long steel angle with an L8 × 8 × 1 cross section. From Appendix C, we find that the thickness of the section is 1 in. and that its area is, 15.00 in². Knowing that $G = 11.2 \times 10^6$ psi, determine (a) the maximum shearing stress along line $a-a$, (b) the angle of twist.

SOLUTION

$$a = \frac{A}{t} = \frac{15 \text{ in}^2}{1 \text{ in.}} = 15 \text{ in.}, \quad b = 1 \text{ in.}, \quad \frac{a}{b} = 15$$

Since $\frac{a}{b} > 5$, $c_1 = c_2 = \frac{1}{3} \left(1 - 0.630 \frac{b}{a} \right)$

or $c_1 = c_2 = \frac{1}{3} \left(1 - \frac{0.630}{15} \right) = 0.3193$

$$T = 36 \times 10^3 \text{ lb} \cdot \text{in.}; \quad L = 120 \text{ in.}; \quad G = 11.2 \times 10^6 \text{ psi}$$

(a) Maximum shearing stress: $\tau_{\max} = \frac{T}{c_1 a b^2}$

$$\tau_{\max} = \frac{36 \times 10^3}{(0.3193)(15)(1)^2} = 7.52 \times 10^3 \text{ psi} \quad \tau_{\max} = 7.52 \text{ ksi} \quad \blacktriangleleft$$

(b) Angle of twist: $\phi = \frac{TL}{c_2 a b^2 G}$

$$\phi = \frac{(36 \times 10^3)(120)}{(0.3193)(15)(1)^3(11.2 \times 10^6)} = 0.08052 \text{ radians} \quad \phi = 4.61^\circ \quad \blacktriangleleft$$

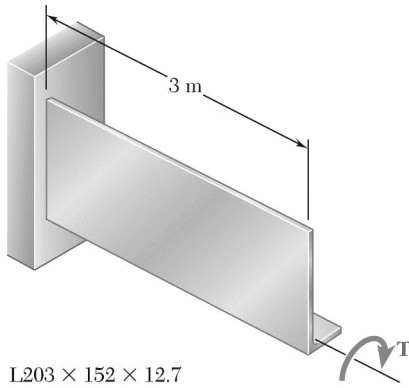

PROBLEM 3.136

A 3-m-long steel angle has an $L203 \times 152 \times 12.7$ cross section. From Appendix C, we find that the thickness of the section is 12.7 mm and that its area is 4350 mm^2 . Knowing that $\tau_{\text{all}} = 50 \text{ MPa}$ and that $G = 77.2 \text{ GPa}$, and ignoring the effect of stress concentration, determine (a) the largest torque T that can be applied, (b) the corresponding angle of twist.

SOLUTION

$$A = 4350 \text{ mm}^2 \quad b = 12.7 \text{ mm} \quad a = ?$$

Equivalent rectangle.

$$a = \frac{A}{b} = \frac{4350}{12.7} = 342.52 \text{ mm}$$

$$\frac{a}{b} = 26.97$$

$$c_1 = c_2 = \frac{1}{3} \left(1 - 0.630 \frac{b}{a} \right) = 0.32555$$

$$(a) \quad \tau_{\text{max}} = \frac{T}{c_1 a b^2} \quad \tau_{\text{max}} = 50 \times 10^6 \text{ Pa}$$

$$T = c_1 a b^2 \tau_{\text{max}} = (0.32555)(26.97 \times 10^{-3})(12.7 \times 10^{-3})^2 (50 \times 10^6)$$

$$= 70.807 \text{ N} \cdot \text{m}$$

$$T = 70.8 \text{ N} \cdot \text{m} \quad \blacktriangleleft$$

$$(b) \quad \varphi = \frac{TL}{c_2 a b^3 G} = \frac{(70.807)(3)}{(0.32555)(26.97 \times 10^{-3})(12.7 \times 10^{-3})(77.2 \times 10^9)}$$

$$= 0.15299 \text{ rad}$$

$$\varphi = 8.77^\circ \quad \blacktriangleleft$$

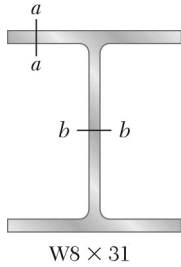

PROBLEM 3.137

An 8-ft-long steel member with a W8 × 31 cross section is subjected to a 5-kip · in. torque. The properties of the rolled-steel section are given in Appendix C. Knowing that $G = 11.2 \times 10^6$ psi, determine (a) the maximum shearing stress along line $a-a$, (b) the maximum shearing stress along line $b-b$, (c) the angle of twist. (*Hint*: consider the web and flanges separately and obtain a relation between the torques exerted on the web and a flange, respectively, by expressing that the resulting angles of twist are equal.)

SOLUTION

Flange:

$$a = 7.995 \text{ in.}, \quad b = 0.435 \text{ in.}, \quad \frac{a}{b} = \frac{7.995}{0.435} = 18.38$$

$$c_1 = c_2 = \frac{1}{3} \left(1 - 0.630 \frac{b}{a} \right) = 0.3219 \quad \varphi_f = \frac{T_f L}{c_2 a b^3 G}$$

$$T_f = c_2 a b^3 \frac{G \varphi_f}{L} = K_f \frac{G \varphi}{L} \quad \text{where} \quad K_f = c_2 a b^3$$

$$K_f = (0.3219)(7.995)(0.435)^3 = 0.2138 \text{ in}^3$$

Web:

$$a = 8.0 - (2)(0.435) = 7.13 \text{ in.}, \quad b = 0.285 \text{ in.}, \quad \frac{a}{b} = \frac{7.13}{0.285} = 25.02$$

$$c_1 = c_2 = \frac{1}{3} \left(1 - 0.630 \frac{b}{a} \right) = 0.3249 \quad \varphi_w = \frac{T_w L}{c_2 a b^3 G}$$

$$T_w = c_2 a b^3 \frac{G \varphi_w}{L} = K_w \frac{G \varphi}{L} \quad \text{where} \quad K_w = c_2 a b^3$$

$$K_w = (0.3249)(7.13)(0.285)^3 = 0.0563 \text{ in}^4$$

For matching twist angles: $\varphi_f = \varphi_w = \varphi$

Total torque.

$$T = 2T_f + T_w = (2K_f + K_w) \frac{G \varphi}{L}$$

$$\frac{G \varphi}{L} = \frac{T}{2K_f + K_w}, \quad T_f = \frac{K_f T}{2K_f + K_w}, \quad T_w = \frac{K_w T}{2K_f + K_w}$$

$$T_f = \frac{(0.2138)(5000)}{(2)(0.2138) + 0.0563} = 2221 \text{ lb} \cdot \text{in.}; \quad T_w = \frac{(0.0563)(5000)}{(2)(0.2138) + 0.0563} = 557 \text{ lb} \cdot \text{in.}$$

(a) $\tau_f = \frac{T_f}{c_1 a b^2} = \frac{2221}{(0.3219)(7.995)(0.435)^2} = 4570 \text{ psi} \quad \tau_f = 4.57 \text{ ksi} \blacktriangleleft$

(b) $\tau_w = \frac{T_w}{c_1 a b^2} = \frac{557}{(0.3249)(7.13)(0.285)^2} = 2960 \text{ psi} \quad \tau_w = 2.96 \text{ ksi} \blacktriangleleft$

(c) $\frac{G \varphi}{L} = \frac{T}{2K_f + K_w} \quad \therefore \quad \varphi = \frac{TL}{G(2K_f + K_w)} \quad \text{where} \quad L = 8 \text{ ft} = 96 \text{ in.}$

$$\varphi = \frac{(5000)(96)}{(11.2 \times 10^6)[(2)(0.2138) + 0.563]} = 88.6 \times 10^{-3} \text{ rad} \quad \varphi = 5.08^\circ \blacktriangleleft$$

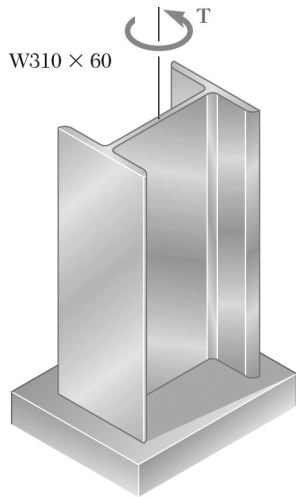

PROBLEM 3.138

A 4-m-long steel member has a W310 × 60 cross section. Knowing that $G = 77.2$ GPa and that the allowable shearing stress is 40 MPa, determine (a) the largest torque T that can be applied, (b) the corresponding angle of twist. Refer to Appendix C for the dimensions of the cross section and neglect the effect of stress concentrations. (See hint of Prob. 3.137.)

SOLUTION

$$W310 \times 60, \quad L = 4 \text{ m}, \quad G = 77.2 \text{ GPa}, \quad \tau_{\text{all}} = 40 \text{ MPa}$$

For one flange: From App. C, $a = 203 \text{ mm}$, $b = 13.1 \text{ mm}$, $a/b = 15.50$

$$\text{Eq. (3.45):} \quad c_1 = c_2 = \frac{1}{3} \left(1 - \frac{0.630}{15.50} \right) = 0.320$$

$$\text{Eq. (3.44):} \quad \phi_f = \frac{T_f L}{c_2 a b^3 G} = \frac{T_f (4)}{0.320 (0.203) (0.0131)^3 (77.2 \times 10^9)} \quad (1)$$

$$\phi_f = 355.04 \times 10^{-6} T_f$$

For web: From App. C, $a = 303 - 2(13.1) = 276.8 \text{ mm}$, $b = 7.5 \text{ mm}$, $a/b = 36.9$

$$\text{Eq. (3.45):} \quad c_1 = c_2 = \frac{1}{3} \left(1 - \frac{0.630}{36.9} \right) = 0.328$$

$$\text{Eq. (3.44):} \quad \phi_w = \frac{T_w (4)}{0.328 (0.2768) (0.0075)^3 (77.2 \times 10^9)}$$

$$\phi_w = 1.354.2 \times 10^{-6} T_w \quad (2)$$

Since angle of twist is the same for flanges and web:

$$\phi_f = \phi_w: \quad 355.04 \times 10^{-6} T_f = 1354.2 \times 10^{-6} T_w$$

$$T_f = 3.814 T_w \quad (3)$$

But the sum of the torques exerted on the two flanges and on the web is equal to the torque T applied to the member:

$$2T_f + T_w = T \quad (4)$$

PROBLEM 3.138 (Continued)

Substituting for T_f from (3) into (4):

$$2(3.814T_w) + T_w = T \quad T_w = 0.11589T \quad (5)$$

From (3): $T_f = 3.814(0.11589T) \quad T_f = 0.44205T \quad (6)$

For one flange:

From Eq. (3.43): $T_f = c_1 ab^2 \tau_{\max} = 0.320(0.203)(0.0131)^2(40 \times 10^6)$
 $= 445.91 \text{ N} \cdot \text{m}$

Eq. (6): $445.91 = 0.44205T \quad T = 1009 \text{ N} \cdot \text{m}$

For web: $T_w = c_1 ab^2 \tau_{\max} = 0.328(0.2768)(0.0075)^2(40 \times 10^6)$
 $= 204.28 \text{ N} \cdot \text{m}$

Eq. (5): $204.28 = 0.11589T \quad T = 1763 \text{ N} \cdot \text{m}$

(a) Largest allowable torque: Use the smaller value. $T = 1009 \text{ N} \cdot \text{m} \blacktriangleleft$

(b) Angle of twist: Use T_f , which is critical.

Eq. (1): $\phi = \phi_f = (355.04 \times 10^{-6})(445.91) = 0.15831 \text{ rad} \quad \phi = 9.07^\circ \blacktriangleleft$

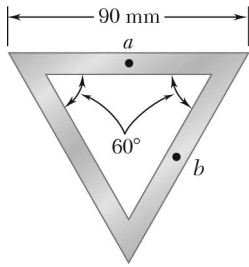

PROBLEM 3.139

A torque $T = 750 \text{ kN} \cdot \text{m}$ is applied to a hollow shaft shown that has a uniform 8-mm wall thickness. Neglecting the effect of stress concentrations, determine the shearing stress at points a and b .

SOLUTION

Detail of corner.

$$\begin{aligned} \frac{1}{2}t &= e \tan 30^\circ \\ e &= \frac{t}{2 \tan 30^\circ} \\ &= \frac{8}{2 \tan 30^\circ} = 6.928 \text{ mm} \\ b &= 90 - 2e = 76.144 \text{ mm} \end{aligned}$$

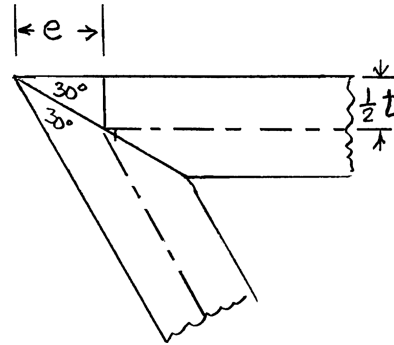

Area bounded by centerline.

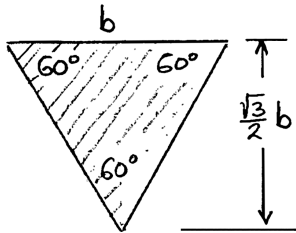

$$\begin{aligned} a &= \frac{1}{2}b \frac{\sqrt{3}}{2} = \frac{\sqrt{3}}{4}b^2 = \frac{\sqrt{3}}{4}(76.144)^2 \\ &= 2510.6 \text{ mm}^2 = 2510.6 \times 10^{-6} \text{ m}^2 \\ t &= 0.008 \text{ m} \end{aligned}$$

$$\tau = \frac{T}{2ta} = \frac{750}{(2)(0.008)(2510 \times 10^{-6})} = 18.67 \times 10^6 \text{ Pa}$$

$$\tau = 18.67 \text{ MPa} \quad \blacktriangleleft$$

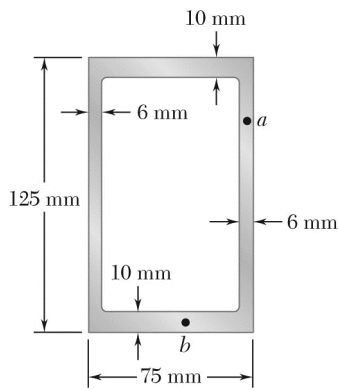

PROBLEM 3.140

A torque $T = 5 \text{ kN} \cdot \text{m}$ is applied to a hollow shaft having the cross section shown. Neglecting the effect of stress concentrations, determine the shearing stress at points a and b .

SOLUTION

$$T = 5 \times 10^3 \text{ N} \cdot \text{m}$$

Area bounded by centerline.

$$\begin{aligned} a &= bh = (69)(115) = 7.935 \times 10^3 \text{ mm}^2 \\ &= 7.935 \times 10^{-3} \text{ m}^2 \end{aligned}$$

At point a :

$$t = 6 \text{ mm} = 0.006 \text{ m}$$

$$\begin{aligned} \tau &= \frac{T}{2ta} = \frac{5 \times 10^3}{(2)(0.006)(7.935 \times 10^{-3})} \\ &= 52.5 \times 10^6 \text{ Pa} \end{aligned}$$

$$\tau = 52.5 \text{ MPa} \quad \blacktriangleleft$$

At point b :

$$t = 10 \text{ mm} = 0.010 \text{ m}$$

$$\tau = \frac{T}{2ta} = \frac{5 \times 10^3}{(2)(0.010)(7.935 \times 10^{-3})} = 31.5 \times 10^6 \text{ Pa}$$

$$\tau = 31.5 \text{ MPa} \quad \blacktriangleleft$$

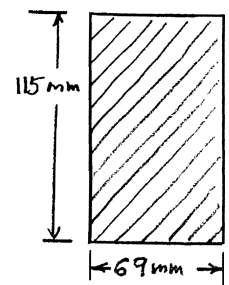

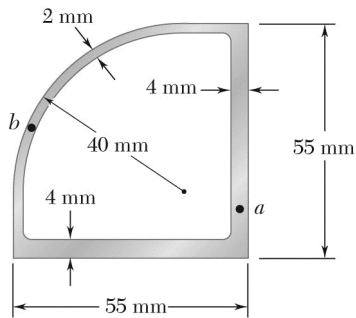

PROBLEM 3.141

A $90\text{-N} \cdot \text{m}$ torque is applied to a hollow shaft having the cross section shown. Neglecting the effect of stress concentrations, determine the shearing stress at points a and b .

SOLUTION

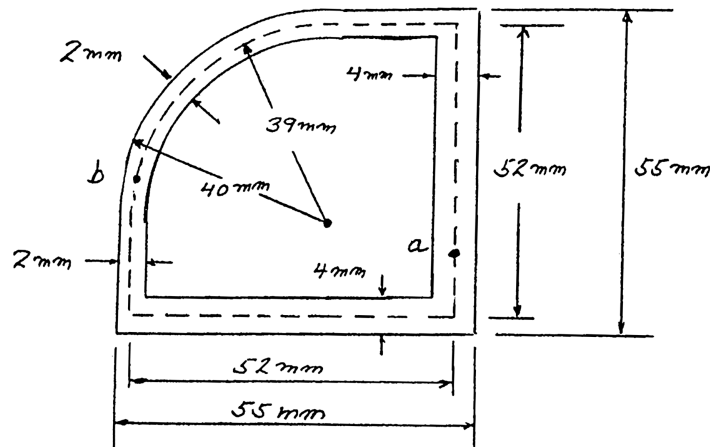

Area bounded by centerline.

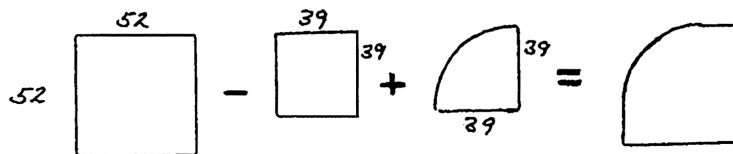

$$a = 52 \times 52 - 39 \times 39 + \frac{\pi}{4}(39)^2 = 2378 \text{ mm}^2 = 2.378 \times 10^{-3} \text{ m}^2$$

$$T = 90 \text{ N} \cdot \text{m}$$

$$\tau_a = \frac{T}{2ta} = \frac{90 \text{ N} \cdot \text{m}}{2(4 \times 10^{-3} \text{ m})(2.378 \times 10^{-3} \text{ m}^2)}$$

$$\tau_a = 4.73 \text{ MPa} \quad \blacktriangleleft$$

$$\tau_b = \frac{T}{2ta} = \frac{90 \text{ N} \cdot \text{m}}{2(2 \times 10^{-3} \text{ m})(2.378 \times 10^{-3} \text{ m}^2)}$$

$$\tau_b = 9.46 \text{ MPa} \quad \blacktriangleleft$$

PROBLEM 3.142

A 5.6 kN·m torque is applied to a hollow shaft having the cross section shown. Neglecting the effect of stress concentrations, determine the shearing stress at points *a* and *b*.

SOLUTION

Area bounded by centerline.

$$a = (96 \text{ mm})(95 \text{ mm}) + \frac{\pi}{2}(47.5 \text{ mm})^2 = 12.664 \times 10^3 \text{ mm}^2$$

$$= 12.664 \times 10^{-3} \text{ m}^2$$

At point *a*, $t = 5 \text{ mm} = 0.005 \text{ m}$

$$\tau = \frac{T}{2at} = \frac{5.6 \times 10^3}{(2)(12.664 \times 10^{-3})(0.005)} = 44.2 \times 10^6 \text{ Pa} \quad \tau = 44.2 \text{ MPa} \blacktriangleleft$$

At point *b*, $t = 8 \text{ mm} = 0.008 \text{ m}$

$$\tau = \frac{T}{2at} = \frac{5.6 \times 10^3}{(2)(12.664 \times 10^{-3})(0.008)} = 27.6 \times 10^6 \text{ Pa} \quad \tau = 27.6 \text{ MPa} \blacktriangleleft$$

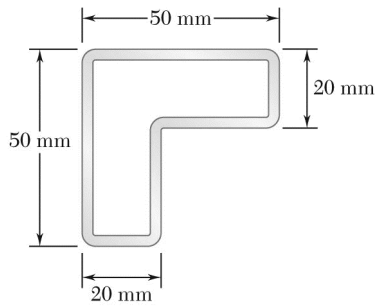

PROBLEM 3.143

A hollow member having the cross section shown is formed from sheet metal of 2-mm thickness. Knowing that the shearing stress must not exceed 3 MPa, determine the largest torque that can be applied to the member.

SOLUTION

Area bounded by centerline.

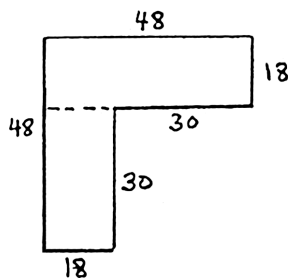

$$a = (48)(18) + (30)(18)$$

$$= 1404 \text{ mm}^2 = 1404 \times 10^{-6} \text{ m}^2$$

$$t = 0.002 \text{ m}$$

$$\tau = \frac{T}{2ta} \quad \text{or} \quad T = 2ta\tau = (2)(0.002)(1404 \times 10^{-6})(3 \times 10^6)$$

$$T = 16.85 \text{ N} \cdot \text{m} \quad \blacktriangleleft$$

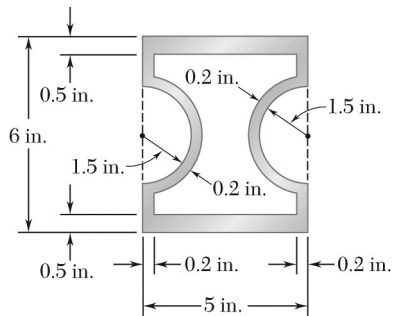

PROBLEM 3.144

A hollow brass shaft has the cross section shown. Knowing that the shearing stress must not exceed 12 ksi and neglecting the effect of stress concentrations, determine the largest torque that can be applied to the shaft.

SOLUTION

Calculate the area bounded by the center line of the wall cross section. The area is a rectangle with two semi-circular cutouts.

$$b = 5 - 0.2 = 4.8 \text{ in.}$$

$$h = 6 - 0.5 = 5.5 \text{ in.}$$

$$r = 1.5 + 0.1 = 1.6 \text{ in.}$$

$$a = bh - 2\left(\frac{\pi}{2}r^2\right) = (4.8)(5.5) - \pi(1.6)^2 = 18.3575 \text{ in}^2$$

$$\tau_{\max} = \frac{T}{2at_{\min}} \quad \tau_{\max} = 12 \times 10^3 \text{ psi} \quad t_{\min} = 0.2 \text{ in.}$$

$$T = 2at_{\min} \tau_{\max} = (2)(18.3575)(0.2)(12 \times 10^3) = 88.116 \times 10^3 \text{ lb} \cdot \text{in}$$

$$T = 88.1 \text{ kip} \cdot \text{in} = 7.34 \text{ kip} \cdot \text{ft} \quad \blacktriangleleft$$

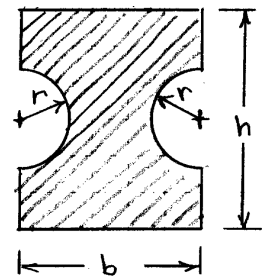

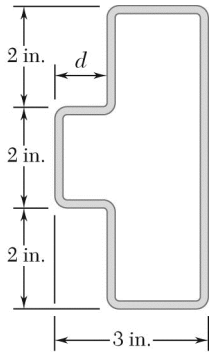

PROBLEM 3.145

A hollow member having the cross section shown is to be formed from sheet metal of 0.06 in. thickness. Knowing that a 1250 lb · in.-torque will be applied to the member, determine the smallest dimension d that can be used if the shearing stress is not to exceed 750 psi.

SOLUTION

Area bounded by centerline.

$$a = (5.94)(2.94 - d) + 1.94d = 17.4636 - 4.00d$$

$$t = 0.06 \text{ in.}, \quad \tau = 750 \text{ psi}, \quad T = 1250 \text{ lb} \cdot \text{in}$$

$$\tau = \frac{T}{2ta}$$

$$a = \frac{T}{2t\tau}$$

$$17.4636 - 4.00d = \frac{1250}{(2)(0.06)(750)} = 13.8889$$

$$d = \frac{3.5747}{4.00} = 0.894 \text{ in.}$$

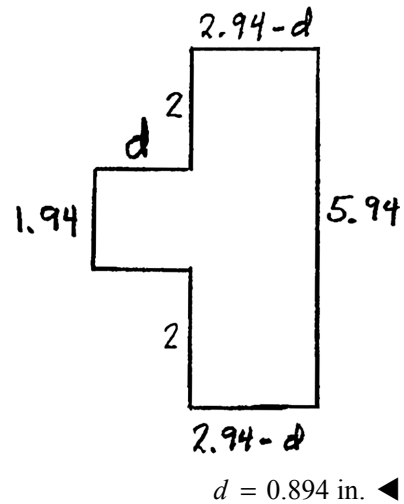

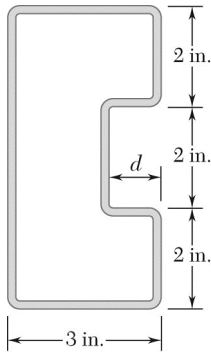

PROBLEM 3.146

A hollow member having the cross section shown is to be formed from sheet metal of 0.06 in. thickness. Knowing that a 1250 lb · in.-torque will be applied to the member, determine the smallest dimension d that can be used if the shearing stress is not to exceed 750 psi.

SOLUTION

Area bounded by centerline.

$$a = (5.94)(2.94) - 2.06d = 17.4636 - 2.06d$$

$$t = 0.06 \text{ in.}, \quad \tau = 750 \text{ psi}, \quad T = 1250 \text{ lb} \cdot \text{in}$$

$$\tau = \frac{T}{2ta}$$

$$a = \frac{T}{2t\tau}$$

$$17.4636 - 2.06d = \frac{1250}{(2)(0.06)(750)} = 13.8889$$

$$d = \frac{3.5747}{2.06} = 1.735 \text{ in.}$$

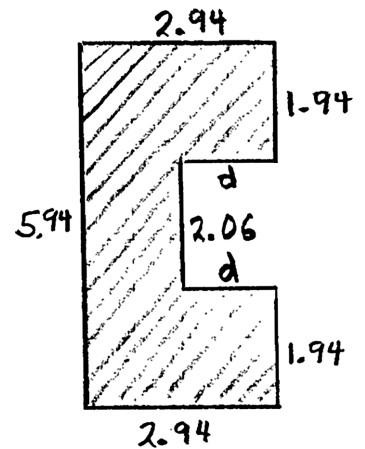

$$d = 1.735 \text{ in.} \quad \blacktriangleleft$$

PROBLEM 3.147

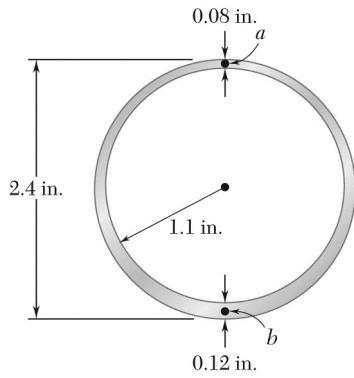

A hollow cylindrical shaft was designed to have a uniform wall thickness of 0.1 in. Defective fabrication, however, resulted in the shaft having the cross section shown. Knowing that a 15 kip · in.-torque is applied to the shaft, determine the shearing stresses at points *a* and *b*.

SOLUTION

Radius of outer circle = 1.2 in.

Radius of inner circle = 1.1 in.

Mean radius = 1.15 in.

Area bounded by centerline.

$$a = \pi r_m^2 = \pi(1.15)^2 = 4.155 \text{ in}^2$$

At point *a*,

$$t = 0.08 \text{ in.}$$

$$\tau = \frac{T}{2ta} = \frac{15}{(2)(0.08)(4.155)} \quad \tau = 22.6 \text{ ksi} \blacktriangleleft$$

At point *b*,

$$t = 0.12 \text{ in.}$$

$$\tau = \frac{T}{2ta} = \frac{15}{(2)(0.12)(4.155)} \quad \tau = 15.04 \text{ ksi} \blacktriangleleft$$

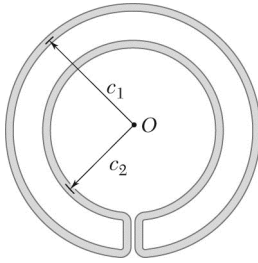

PROBLEM 3.148

A cooling tube having the cross section shown is formed from a sheet of stainless steel of 3-mm thickness. The radii $c_1 = 150$ mm and $c_2 = 100$ mm are measured to the center line of the sheet metal. Knowing that a torque of magnitude $T = 3$ kN · m is applied to the tube, determine (a) the maximum shearing stress in the tube, (b) the magnitude of the torque carried by the outer circular shell. Neglect the dimension of the small opening where the outer and inner shells are connected.

SOLUTION

Area bounded by centerline.

$$\begin{aligned}
 a &= \pi(c_1^2 - c_2^2) = \pi(150^2 - 100^2) = 39.27 \times 10^3 \text{ mm}^2 \\
 &= 39.27 \times 10^{-3} \text{ m}^2 \\
 t &= 0.003 \text{ m}
 \end{aligned}$$

$$(a) \quad \tau = \frac{T}{2ta} = \frac{3 \times 10^3}{(2)(0.003)(39.27 \times 10^{-3})} = 12.73 \times 10^6 \text{ Pa} \qquad \tau = 12.76 \text{ MPa} \quad \blacktriangleleft$$

$$\begin{aligned}
 (b) \quad T_1 &= (2\pi c_1 t \tau c_1) = 2\pi c_1^2 t \tau \\
 &= 2\pi(0.150)^2(0.003)(12.73 \times 10^6) = 5.40 \times 10^3 \text{ N} \cdot \text{m} \qquad T_1 = 5.40 \text{ kN} \cdot \text{m} \quad \blacktriangleleft
 \end{aligned}$$

PROBLEM 3.149

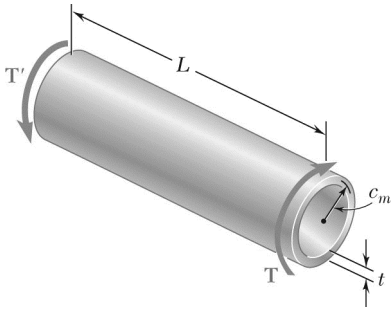

A hollow cylindrical shaft of length L , mean radius c_m , and uniform thickness t is subjected to a torque of magnitude T . Consider, on the one hand, the values of the average shearing stress τ_{ave} and the angle of twist ϕ obtained from the elastic torsion formulas developed in Sections 3.4 and 3.5 and, on the other hand, the corresponding values obtained from the formulas developed in Sec. 3.13 for thin-walled shafts. (a) Show that the relative error introduced by using the thin-walled-shaft formulas rather than the elastic torsion formulas is the same for τ_{ave} and ϕ and that the relative error is positive and proportional to the ratio t/c_m . (b) Compare the percent error corresponding to values of the ratio t/c_m of 0.1, 0.2, and 0.4.

SOLUTION

Let $c_2 = \text{outer radius} = c_m + \frac{1}{2}t$ and $c_1 = \text{inner radius} = c_m - \frac{1}{2}t$

$$\begin{aligned} J &= \frac{\pi}{2}(c_2^4 - c_1^4) = \frac{\pi}{2}(c_2^2 + c_1^2)(c_2 + c_1)(c_2 - c_1) \\ &= \frac{\pi}{2}\left(c_m^2 + c_m t + \frac{1}{4}t^2 + c_m^2 - c_m t + \frac{1}{4}t^2\right)(2c_m)t \\ &= 2\pi\left(c_m^2 + \frac{1}{4}t^2\right)c_m t \end{aligned}$$

$$\tau_m = \frac{Tc_m}{J} = \frac{T}{2\pi\left(c_m^2 + \frac{1}{4}t^2\right)t}$$

$$\phi_1 = \frac{TL}{JG} = \frac{TL}{2\pi\left(c_m^2 + \frac{1}{4}t^2\right)c_m t G}$$

Area bounded by centerline.

$$a = \pi c_m^2$$

$$\tau_{\text{ave}} = \frac{T}{2ta} = \frac{T}{2\pi c_m^2 t}$$

$$\phi_2 = \frac{TL}{4a^2 G} \oint \frac{ds}{t} = \frac{TL(2\pi c_m/t)}{4(\pi c_m^2)^2 G} = \frac{TL}{2\pi c_m^3 t G}$$

(a) Ratios:

$$\frac{\tau_{\text{ave}}}{\tau_m} = \frac{T}{2\pi c_m^2 t} \times \frac{2\pi\left(c_m^2 + \frac{1}{4}t^2\right)t}{T} = 1 + \frac{1}{4} \frac{t^2}{c_m^2} \quad \blacktriangleleft$$

$$\frac{\phi_2}{\phi_1} = \frac{TL}{2\pi c_m^3 t G} \times \frac{2\pi\left(c_m^2 + \frac{1}{4}t^2\right)c_m t G}{TL} = 1 + \frac{1}{4} \frac{t^2}{c_m^2} \quad \blacktriangleleft$$

PROBLEM 3.149 (Continued)

(b)
$$\frac{\tau_{\text{ave}}}{\tau_m} - 1 = \frac{\phi_2}{\phi_1} - 1 = \frac{1}{4} \frac{t^2}{c_m^2}$$

$\frac{t}{c_m}$	0.1	0.2	0.4
$\frac{1}{4} \frac{t^2}{c_m^2}$	0.0025	0.01	0.04
%	0.25%	1%	4%



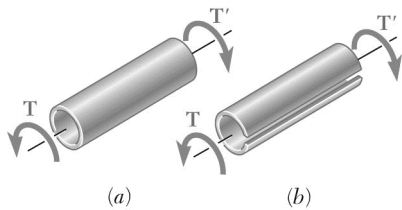

PROBLEM 3.150

Equal torques are applied to thin-walled tubes of the same length L , same thickness t , and same radius c . One of the tubes has been slit lengthwise as shown. Determine (a) the ratio τ_b / τ_a of the maximum shearing stresses in the tubes, (b) the ratio ϕ_b / ϕ_a of the angles of twist of the shafts.

SOLUTION

Without slit:

Area bounded by centerline. $a = \pi c^2$

$$\tau_a = \frac{T}{2ta} = \frac{T}{2\pi c^2 t}$$

$$J \approx 2\pi c^3 t \quad \phi_a = \frac{TL}{GJ} = \frac{TL}{2\pi c^3 t G}$$

With slit:

$$a = 2\pi c, \quad b = t, \quad \frac{a}{b} = \frac{2\pi c}{t} \gg 1$$

$$c_1 = c_2 = \frac{1}{3}$$

$$\tau_b = \frac{T}{c_1 a b^2} = \frac{3T}{2\pi c t^2}$$

$$\phi_b = \frac{T}{c_2 a b^3 G} = \frac{3TL}{2\pi c t^3 G}$$

(a) Stress ratio:

$$\frac{\tau_b}{\tau_a} = \frac{3T}{2\pi c t^2} \cdot \frac{2\pi c^2 t}{T} = \frac{3c}{t} \quad \frac{\tau_b}{\tau_a} = \frac{3c}{t} \blacktriangleleft$$

(b) Twist ratio:

$$\frac{\phi_b}{\phi_a} = \frac{3TL}{2\pi c t^3 G} \cdot \frac{2\pi c^3 t G}{TL} = \frac{3c^2}{t^2} \quad \frac{\phi_b}{\phi_a} = \frac{3c^2}{t^2} \blacktriangleleft$$

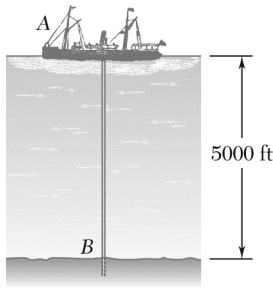

PROBLEM 3.151

The ship at *A* has just started to drill for oil on the ocean floor at a depth of 5000 ft. Knowing that the top of the 8-in.-diameter steel drill pipe ($G = 11.2 \times 10^6$ psi) rotates through two complete revolutions before the drill bit at *B* starts to operate, determine the maximum shearing stress caused in the pipe by torsion.

SOLUTION

$$\phi = \frac{TL}{GJ} \quad T = \frac{GJ\phi}{L}$$

$$\tau = \frac{Tc}{J} = \frac{GJ\phi c}{JL} = \frac{G\phi c}{L}$$

$$\phi = 2 \text{ rev} = (2)(2\pi) = 12.566 \text{ rad}, \quad c = \frac{1}{2}d = 4.0 \text{ in.}$$

$$L = 5000 \text{ ft} = 60000 \text{ in.}$$

$$\tau = \frac{(11.2 \times 10^6)(12.566)(4.0)}{60000} = 9.3826 \times 10^3 \text{ psi}$$

$$\tau = 9.38 \text{ ksi} \quad \blacktriangleleft$$

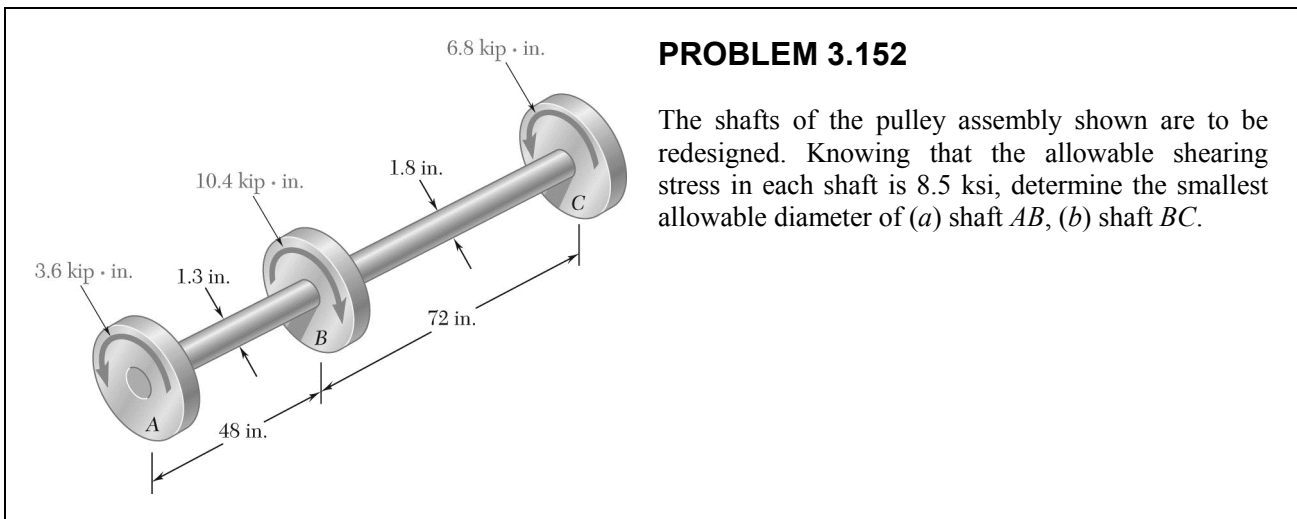

SOLUTION

(a) Shaft *AB*: $T_{AB} = 3.6 \times 10^3 \text{ lb} \cdot \text{in}$

$\tau_{\max} = 8.5 \text{ ksi} = 8.5 \times 10^3 \text{ psi}$

$$J = \frac{\pi}{2}c^4 \quad \tau_{\max} = \frac{Tc}{J} = \frac{2T}{\pi c^3}$$

$$c = \sqrt[3]{\frac{2T_{AB}}{\pi\tau_{\max}}} = \sqrt[3]{\frac{(2)(3.6 \times 10^3)}{\pi(8.5 \times 10^3)}} = 0.646 \text{ in.} \quad d_{AB} = 2c = 1.292 \text{ in.} \blacktriangleleft$$

(b) Shaft *BC*: $T_{BC} = 6.8 \times 10^3 \text{ lb} \cdot \text{in}$

$\tau_{\max} = 8.5 \times 10^3 \text{ psi}$

$$c = \sqrt[3]{\frac{2T_{BC}}{\pi\tau_{\max}}} = \sqrt[3]{\frac{(2)(6.8 \times 10^3)}{\pi(8.5 \times 10^3)}} = 0.7985 \text{ in.}$$

$$d_{BC} = 2c = 1.597 \text{ in.} \blacktriangleleft$$

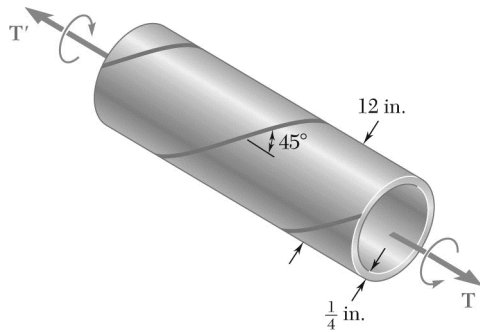

PROBLEM 3.153

A steel pipe of 12-in. outer diameter is fabricated from $\frac{1}{4}$ -in.-thick plate by welding along a helix which forms an angle of 45° with a plane perpendicular to the axis of the pipe. Knowing that the maximum allowable tensile stress in the weld is 12 ksi, determine the largest torque that can be applied to the pipe.

SOLUTION

From Eq. (3.14) of the textbook,

$$\sigma_{45} = \tau_{\max}$$

hence,

$$\tau_{\max} = 12 \text{ ksi} = 12 \times 10^3 \text{ psi}$$

$$c_2 = \frac{1}{2}d_0 = \frac{1}{2}(12) = 6.00 \text{ in.}$$

$$c_1 = c_2 - t = 6.00 - 0.25 = 5.75 \text{ in.}$$

$$J = \frac{\pi}{2}(c_2^4 - c_1^4) = \frac{\pi}{2}[(6.00)^4 - (5.75)^4] = 318.67 \text{ in.}^4$$

$$\tau_{\max} = \frac{Tc}{J} \quad T = \frac{\tau_{\max}J}{c}$$

$$T = \frac{(12 \times 10^3)(318.67)}{6.00} = 637 \times 10^3 \text{ lb} \cdot \text{in}$$

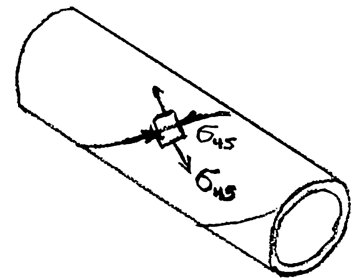

$$T = 637 \text{ kip} \cdot \text{in} \quad \blacktriangleleft$$

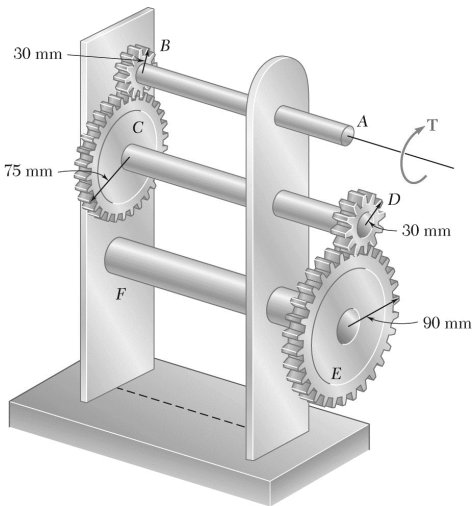

PROBLEM 3.154

For the gear train shown, the diameters of the three solid shafts are:

$$d_{AB} = 20 \text{ mm} \quad d_{CD} = 25 \text{ mm} \quad d_{EF} = 40 \text{ mm}$$

Knowing that for each shaft the allowable shearing stress is 60 MPa, determine the largest torque T that can be applied.

SOLUTION

Statics: $T_{AB} = T$

$$\frac{T_{CD}}{r_C} = \frac{T_{AB}}{r_B} \quad T_{CD} = \frac{r_C}{r_B} T_{AB} = \frac{75}{30} T = 2.5T$$

$$\frac{T_{EF}}{r_F} = \frac{T_{CD}}{r_D} \quad T_{EF} = \frac{r_F}{r_D} T_{CD} = \frac{90}{30} (2.5T) = 7.5T$$

Determine the magnitude of T so that the stress is $60 \text{ MPa} = 60 \times 10^6 \text{ Pa}$.

$$\tau = \frac{Tc}{J} \quad T_{\text{shaft}} = \frac{J\tau}{c} = \frac{\pi}{2} \tau c^3$$

Shaft AB: $c = \frac{1}{2} d_{AB} = 10 \text{ mm} = 0.010 \text{ m}$

$$T_{AB} = T = \frac{\pi}{2} (60 \times 10^6) (0.010)^3 \quad T = 94.2 \text{ N} \cdot \text{m}$$

Shaft CD: $c = \frac{1}{2} d_{CD} = 12.5 \text{ mm} = 0.0125 \text{ m}$

$$T_{CD} = 2.5T = \frac{\pi}{2} (60 \times 10^6) (0.0125)^3 \quad T = 73.6 \text{ N} \cdot \text{m}$$

Shaft EF: $c = \frac{1}{2} d_{EF} = 20 \text{ mm} = 0.020 \text{ m}$

$$T_{EF} = 7.5T = \frac{\pi}{2} (60 \times 10^6) (0.020)^3 \quad T = 100.5 \text{ N} \cdot \text{m}$$

The smallest value of T is the largest torque that can be applied.

$$T = 73.6 \text{ N} \cdot \text{m} \quad \blacktriangleleft$$

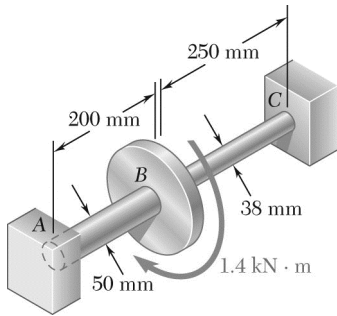

PROBLEM 3.155

Two solid steel shafts ($G = 77.2 \text{ GPa}$) are connected to a coupling disk B and to fixed supports at A and C . For the loading shown, determine (a) the reaction at each support, (b) the maximum shearing stress in shaft AB , (c) the maximum shearing stress in shaft BC .

SOLUTION

Shaft AB: $T = T_{AB}$, $L_{AB} = 0.200 \text{ m}$, $c = \frac{1}{2}d = 25 \text{ mm} = 0.025 \text{ m}$

$$J_{AB} = \frac{\pi}{2}c^4 = \frac{\pi}{2}(0.025)^4 = 613.59 \times 10^{-9} \text{ m}^4 \quad \phi_B = \frac{T_{AB}L_{AB}}{GJ_{AB}}$$

$$T_{AB} = \frac{GJ_{AB}}{L_{AB}}\phi_B = \frac{(77.2 \times 10^9)(613.59 \times 10^{-9})}{0.200}\phi_B = 236.847 \times 10^3 \phi_B$$

Shaft BC: $T = T_{BC}$, $L_{BC} = 0.250 \text{ m}$, $c = \frac{1}{2}d = 19 \text{ mm} = 0.019 \text{ m}$

$$J_{BC} = \frac{\pi}{2}c^4 = \frac{\pi}{2}(0.019)^4 = 204.71 \times 10^{-9} \text{ m}^4 \quad \phi_B = \frac{T_{BC}L_{BC}}{GJ_{BC}}$$

$$T_{BC} = \frac{GJ_{BC}}{L_{BC}}\phi_B = \frac{(77.2 \times 10^9)(204.71 \times 10^{-9})}{0.250} = 63.214 \times 10^3 \phi_B$$

Equilibrium of coupling disk. $T = T_{AB} + T_{BC}$

$$1.4 \times 10^3 = 236.847 \times 10^3 \phi_B + 63.214 \times 10^3 \phi_B \quad \phi_B = 4.6657 \times 10^{-3} \text{ rad.}$$

$$T_{AB} = (236.847 \times 10^3)(4.6657 \times 10^{-3}) = 1.10506 \times 10^3 \text{ N} \cdot \text{m}$$

$$T_{BC} = (63.214 \times 10^3)(4.6657 \times 10^{-3}) = 294.94 \text{ N} \cdot \text{m}$$

(a) Reactions at supports.

$$T_A = T_{AB} = 1105 \text{ N} \cdot \text{m} \quad \blacktriangleleft$$

$$T_C = T_{BC} = 295 \text{ N} \cdot \text{m} \quad \blacktriangleleft$$

(b) Maximum shearing stress in AB.

$$\tau_{AB} = \frac{T_{AB}c}{J_{AB}} = \frac{(1.10506 \times 10^3)(0.025)}{613.59 \times 10^{-9}} = 45.0 \times 10^6 \text{ Pa} \quad \tau_{AB} = 45.0 \text{ MPa} \quad \blacktriangleleft$$

(c) Maximum shearing stress in BC.

$$\tau_{BC} = \frac{T_{BC}c}{J_{BC}} = \frac{(294.94)(0.019)}{204.71 \times 10^{-9}} = 27.4 \times 10^6 \text{ Pa} \quad \tau_{BC} = 27.4 \text{ MPa} \quad \blacktriangleleft$$

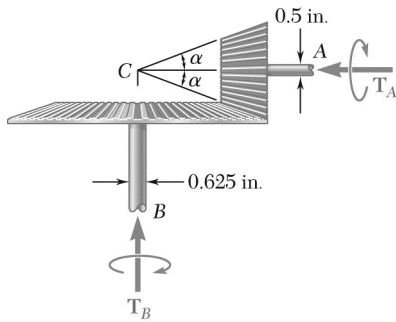

PROBLEM 3.156

In the bevel-gear system shown, $\alpha = 18.43^\circ$. Knowing that the allowable shearing stress is 8 ksi in each shaft and that the system is in equilibrium, determine the largest torque T_A that can be applied at A .

SOLUTION

Using stress limit for shaft A :

$$\tau = 8 \text{ ksi}, \quad c = \frac{1}{2}d = 0.25 \text{ in.}$$

$$T_A = \frac{J\tau}{c} = \frac{\pi}{2}\tau c^3 = \frac{\pi}{2}(8)(0.25)^3 = 0.1963 \text{ kip} \cdot \text{in}$$

Using stress limit for shaft B :

$$\tau = 8 \text{ ksi}, \quad c = \frac{1}{2}d = 0.3125 \text{ in.}$$

$$T_B = \frac{J\tau}{c} = \frac{\pi}{2}\tau c^3 = \frac{\pi}{2}(8)(0.3125)^3 = 0.3835 \text{ kip} \cdot \text{in}$$

From statics,

$$T_A = \frac{r_A}{r_B}T_B = (\tan \alpha)T_B$$

$$T_A = (\tan 18.43^\circ)(0.3835) = 0.1278 \text{ kip} \cdot \text{in}$$

The allowable value of T_A is the smaller.

$$T_A = 0.1278 \text{ kip} \cdot \text{in}$$

$$T_A = 127.8 \text{ lb} \cdot \text{in} \quad \blacktriangleleft$$

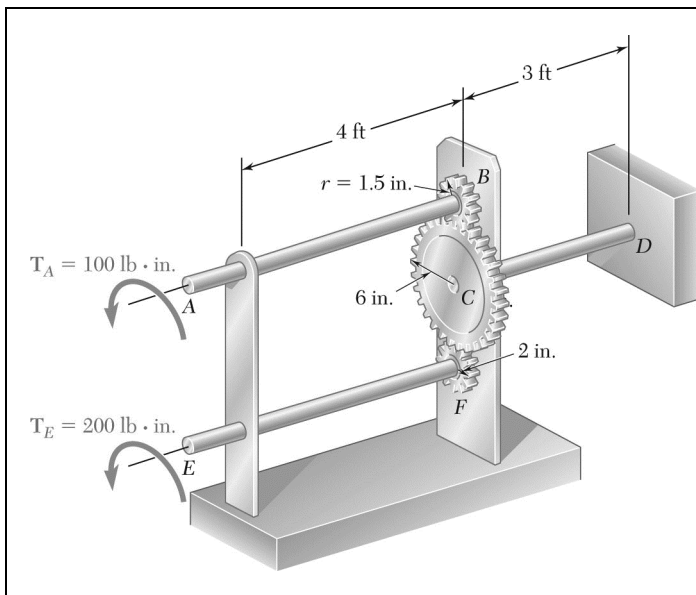

PROBLEM 3.157

Three solid shafts, each of $\frac{3}{4}$ -in. diameter, are connected by the gears shown. Knowing that $G = 11.2 \times 10^6$ psi, determine (a) the angle through which end *A* of shaft *AB* rotates, (b) the angle through which end *E* of shaft *EF* rotates.

SOLUTION

Geometry:

$$r_B = 1.5 \text{ in.}, \quad r_C = 6 \text{ in.}, \quad r_F = 2 \text{ in.}$$

$$L_{AB} = 48 \text{ in.}, \quad L_{CD} = 36 \text{ in.}, \quad L_{EF} = 48 \text{ in.}$$

Statics:

$$T_A = 100 \text{ lb} \cdot \text{in} \curvearrowright$$

$$T_E = 200 \text{ lb} \cdot \text{in} \curvearrowright$$

Gear *B*:

$$+\curvearrowright \Sigma M_B = 0:$$

$$-r_B F_1 + T_A = 0$$

$$-1.5 F_1 + 100 = 0$$

$$F_1 = 67.667 \text{ lb}$$

Gear *F*:

$$+\curvearrowright \Sigma M_F = 0:$$

$$-r_F F_2 + T_E = 0$$

$$-2 F_2 + 200 = 0$$

$$F_2 = 100 \text{ lb}$$

Gear *C*:

$$+\curvearrowright \Sigma M_C = 0:$$

$$-r_C F_1 - r_C F_2 + T_C = 0$$

$$-(6)(67.667) - (6)(100) + T_C = 0$$

$$T_C = 1000 \text{ lb} \cdot \text{in} \curvearrowright$$

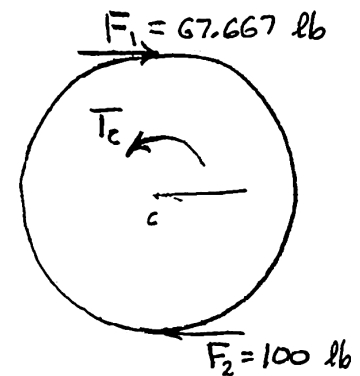
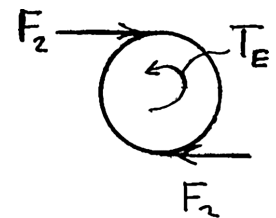
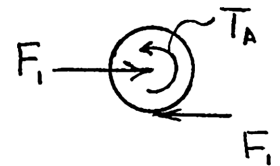

PROBLEM 3.157 (Continued)

Deformations:

For all shafts, $c = \frac{1}{2}d = 0.375 \text{ in.}$

$$J = \frac{\pi}{2}c^4 = 0.031063 \text{ in}^4$$

$$\varphi_{A/B} = \frac{T_{AB}L_{AB}}{GJ} = \frac{(100)(48)}{(11.2 \times 10^6)(0.031063)} = 0.013797 \text{ rad } \curvearrowright$$

$$\varphi_{E/F} = \frac{T_{EF}L_{EF}}{GJ} = \frac{(200)(48)}{(11.2 \times 10^6)(0.031063)} = 0.027594 \text{ rad } \curvearrowright$$

$$\varphi_{C/D} = \frac{T_{CD}L_{CD}}{GJ} = \frac{(1000)(36)}{(11.2 \times 10^6)(0.031063)} = 0.103476 \text{ rad } \curvearrowright$$

Kinematics: $\varphi_C = \varphi_{C/D} = 0.103476 \text{ rad } \curvearrowright$

$$r_B\varphi_B = r_C\varphi_C \quad \varphi_B = \frac{r_C}{r_B}\varphi_C \frac{6}{1.5}(0.103476) = 0.41390 \text{ rad } \curvearrowright$$

(a) $\varphi_A = \varphi_B + \varphi_{A/B} = 0.41390 + 0.01397 = 0.42788 \text{ rad } \curvearrowright$ $\varphi_A = 24.5^\circ \curvearrowright \blacktriangleleft$

$$r_F\varphi_F = r_C\varphi_C \quad \varphi_F = \frac{r_C}{r_F}\varphi_C = \frac{6}{2}(0.103476) = 0.31043 \text{ rad } \curvearrowright$$

(b) $\varphi_E = \varphi_F + \varphi_{E/F} = 0.31043 + 0.027594 = 0.33802 \text{ rad } \curvearrowright$ $\varphi_E = 19.37^\circ \curvearrowright \blacktriangleleft$

PROBLEM 3.158

The design specifications of a 1.2-m-long solid transmission shaft require that the angle of twist of the shaft not exceed 4° when a torque of $750 \text{ N} \cdot \text{m}$ is applied. Determine the required diameter of the shaft, knowing that the shaft is made of a steel with an allowable shearing stress of 90 MPa and a modulus of rigidity of 77.2 GPa .

SOLUTION

$$T = 750 \text{ N} \cdot \text{m}, \quad \phi = 4^\circ = 69.813 \times 10^{-3} \text{ rad},$$

$$L = 1.2 \text{ m}, \quad J = \frac{\pi}{2} c^4$$

$$\tau = 90 \text{ MPa} = 90 \times 10^6 \text{ Pa} \quad G = 77.2 \text{ GPa} = 77.2 \times 10^9 \text{ Pa}$$

Based on angle of twist. $\phi = \frac{TL}{GJ} = \frac{2TL}{\pi G c^4}$

$$c = \sqrt[4]{\frac{2TL}{\pi G \phi}} = \sqrt[4]{\frac{(2)(750)(1.2)}{\pi(77.2 \times 10^9)(69.813 \times 10^{-3})}} = 18.06 \times 10^{-3} \text{ m}$$

Based on shearing stress. $\tau = \frac{Tc}{J} = \frac{2T}{\pi c^3}$

$$c = \sqrt[3]{\frac{2T}{\pi \tau}} = \sqrt[3]{\frac{(2)(750)}{\pi(90 \times 10^6)}} = 17.44 \times 10^{-3} \text{ m}$$

Use larger value.

$$c = 18.06 \times 10^{-3} \text{ m} = 18.06 \text{ mm}$$

$$d = 2c = 36.1 \text{ mm} \quad \blacktriangleleft$$

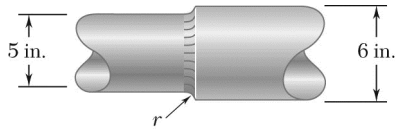

PROBLEM 3.159

The stepped shaft shown rotates at 450 rpm. Knowing that $r = 0.5$ in., determine the maximum power that can be transmitted without exceeding an allowable shearing stress of 7500 psi.

SOLUTION

$$d = 5 \text{ in.}$$

$$D = 6 \text{ in.}$$

$$r = 0.5 \text{ in.}$$

$$\frac{D}{d} = \frac{6}{5} = 1.20$$

$$\frac{r}{d} = \frac{0.5}{5} = 0.10$$

$$K = 1.33$$

From Fig. 3.32,

For smaller side,

$$c = \frac{1}{2}d = 2.5 \text{ in.}$$

$$\tau = \frac{KTc}{J} = \frac{2KT}{\pi c^3}$$

$$T = \frac{\pi c^3 \tau}{2K} = \frac{\pi(2.5)^3(7500)}{(2)(1.33)} = 138.404 \times 10^3 \text{ lb} \cdot \text{in}$$

$$f = 450 \text{ rpm} = 7.5 \text{ Hz}$$

Power.

$$P = 2\pi f T = 2\pi(7.5)(138.404 \times 10^3) = 6.52 \times 10^6 \text{ in} \cdot \text{lb/s}$$

Recalling that 1 hp = 6600 in · lb/s,

$$P = 988 \text{ hp} \blacktriangleleft$$

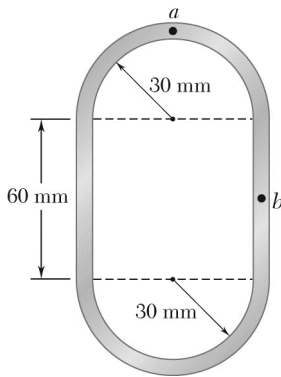

PROBLEM 3.160

A 750-N · m torque is applied to a hollow shaft having the cross section shown and a uniform 6-mm wall thickness. Neglecting the effect of stress concentrations, determine the shearing stress at points *a* and *b*.

SOLUTION

Area bounded by centerline.

$$\begin{aligned}
 a &= 2 \frac{\pi}{2} (33)^2 + (60)(66) = 7381 \text{ mm}^2 \\
 &= 7381 \times 10^{-6} \text{ m}^2 \\
 t &= 0.006 \text{ m at both } a \text{ and } b,
 \end{aligned}$$

Then at points *a* and *b*,

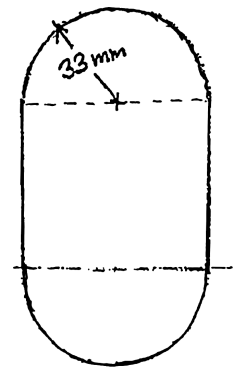

$$\tau = \frac{T}{2ta} = \frac{750}{(2)(0.006)(7381 \times 10^{-6})} = 8.47 \times 10^6 \text{ Pa}$$

$$\tau = 8.47 \text{ MPa} \blacktriangleleft$$

PROBLEM 3.161

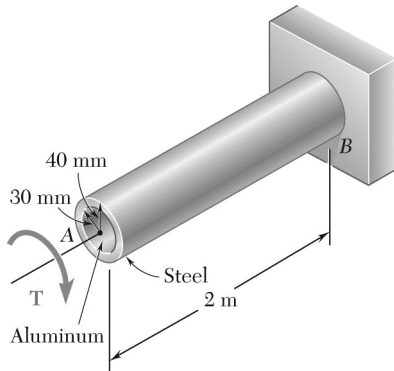

The composite shaft shown is twisted by applying a torque T at end A . Knowing that the maximum shearing stress in the steel shell is 150 MPa, determine the corresponding maximum shearing stress in the aluminum core. Use $G = 77.2$ GPa for steel and $G = 27$ GPa for aluminum.

SOLUTION

Let G_1 , J_1 , and τ_1 refer to the aluminum core and G_2 , J_2 , and τ_2 refer to the steel shell.

At the outer surface on the steel shell,

$$\gamma_2 = \frac{c_2 \phi}{L} \quad \therefore \quad \frac{\phi}{L} = \frac{\gamma_2}{c_2} = \frac{\tau_2}{c_2 G_2}$$

At the outer surface of the aluminum core,

$$\gamma_1 = \frac{c_1 \phi}{L} \quad \therefore \quad \frac{\phi}{L} = \frac{\gamma_1}{c_1} = \frac{\tau_1}{c_1 G_1}$$

Matching $\frac{\phi}{L}$ for both components,

$$\frac{\tau_2}{c_2 G_2} = \frac{\tau_1}{c_1 G_1}$$

$$\text{Solving for } \tau_2, \quad \tau_2 = \frac{c_2}{c_1} \cdot \frac{G_2}{G_1} \tau_1 = \frac{0.030}{0.040} \cdot \frac{27 \times 10^9}{77.2 \times 10^9} \cdot 150 \times 10^6 = 39.3 \times 10^6 \text{ Pa}$$

$$\tau_2 = 39.3 \text{ MPa} \quad \blacktriangleleft$$

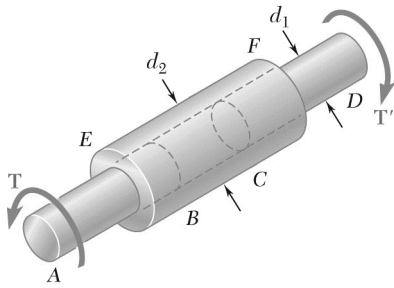

PROBLEM 3.162

Two solid brass rods AB and CD are brazed to a brass sleeve EF . Determine the ratio d_2/d_1 for which the same maximum shearing stress occurs in the rods and in the sleeve.

SOLUTION

Let
$$c_1 = \frac{1}{2}d_1 \quad \text{and} \quad c_2 = \frac{1}{2}d_2$$

Shaft AB :
$$\tau_1 = \frac{Tc_1}{J_1} = \frac{2T}{\pi c_1^3}$$

Sleeve EF :
$$\tau_2 = \frac{Tc_2}{J_2} = \frac{2Tc_2}{\pi(c_2^4 - c_1^4)}$$

For equal stresses,
$$\frac{2T}{\pi c_1^3} = \frac{2Tc_2}{\pi(c_2^4 - c_1^4)}$$

$$c_2^4 - c_1^4 = c_1^3 c_2$$

Let $x = \frac{c_2}{c_1}$
$$x^4 - 1 = x \quad \text{or} \quad x = \sqrt[4]{1+x}$$

Solve by successive approximations starting with $x_0 = 1.0$.

$$x_1 = \sqrt[4]{2} = 1.189, \quad x_2 = \sqrt[4]{2.189} = 1.216, \quad x_3 = \sqrt[4]{2.216} = 1.220$$

$$x_4 = \sqrt[4]{2.220} = 1.221, \quad x_5 = \sqrt[4]{2.221} = 1.221 \quad (\text{converged}).$$

$$x = 1.221 \quad \frac{c_2}{c_1} = 1.221$$

$$\frac{d_2}{d_1} = 1.221 \quad \blacktriangleleft$$