

A

MAT 2322 D Winter 2016 February 25th, 14:30 Prof. Desjardins

TEST #1

Max = 20

Name: \_\_\_\_\_ Solutions

Student Number: \_\_\_\_\_

- Time: 80 min.
- Verify that your copy of the midterm has exactly 6 pages (including this one).
- There are 5 questions worth 4 marks each for a total of 20 points.
- Only basic scientific calculators are permitted: non-programmable, non-graphing.
- Work all problems in the space provided. Use the backs of the pages for rough work if necessary. Do not use any other paper.
- Cellular phones, unauthorized electronic devices or course notes are not allowed during this exam. Phones and devices must be turned off and put away in your bag. Do not keep them in your possession, such as in your pockets. If caught with such a device or document, the following may occur: you will be asked to leave immediately the exam, academic fraud allegations will be filed which may result in you obtaining a 0 (zero) for the exam. By signing below, you acknowledge that you have ensured that you are complying with the above statement.

Signature: \_\_\_\_\_

(A)

2

1. Find and classify the critical points of the following function.

$$f(x, y) = x^2 - xy^2 + 2y^2$$

$$f_x = 2x - y^2 \quad f_x = 0 \text{ if } y^2 = 2x$$

$$f_y = -2xy + 4y = 2y(2 - x)$$

$$f_y = 0 \text{ if } x = 2 \text{ or } y = 0$$

$$\text{if } x = 2, \quad y^2 = 4 \Rightarrow y = \pm 2 \Rightarrow (2, 2) \text{ and } (2, -2)$$

$$\text{if } y = 0, \quad x = 0 \Rightarrow (0, 0)$$

$$f_{xx} = 2, \quad f_{xy} = -2y, \quad f_{yy} = -2x + 4$$

$$D = f_{xx} f_{yy} - (f_{xy})^2 = 2(-2x + 4) - (-2y)^2 \\ = 8 - 4x - 4y^2$$

$$D(0, 0) = 8 \quad f_{xx}(0, 0) = 2 \Rightarrow \boxed{(0, 0) \text{ local min}}$$

$$D(2, 2) = -16 \Rightarrow \boxed{(2, 2) \text{ saddle point}}$$

$$D(2, -2) = -16 \Rightarrow \boxed{(2, -2) \text{ saddle point}}$$

(A)

3

2. Use the method of Lagrange multipliers to determine the absolute minimum and maximum values of the function  $f(x, y) = x^2 - 4x + y^2$  on the circle  $x^2 + y^2 = 1$ .

$$f(x, y) = x^2 - 4x + y^2 \quad g(x, y) = x^2 + y^2 = 1$$

$$Df = \lambda Dg \Rightarrow f_x = \lambda g_x \Rightarrow 2x - 4 = 2\lambda x$$

$$\text{or } x - 2 = \lambda x \Rightarrow \lambda \neq 1$$

$$f_y = \lambda g_y \Rightarrow 2y = 2\lambda y$$

$$\text{or } y = \lambda y \Rightarrow y = 0$$

$$\text{if } y = 0, x^2 = 1 \Rightarrow x = \pm 1$$

so 2 points  $(1, 0)$  and  $(-1, 0)$

$$f(1, 0) = -3$$

$$f(-1, 0) = 5$$

$$\therefore \text{min } -3 \text{ and max } 5$$

3. Calculate the following integral.

$$\int_0^4 \int_{\sqrt{y}}^2 \sqrt{x^3+1} \, dx \, dy$$

have to switch order of integration

$x$  goes  $\sqrt{y}$  to 2, then  $y$  0 to 4

so region is

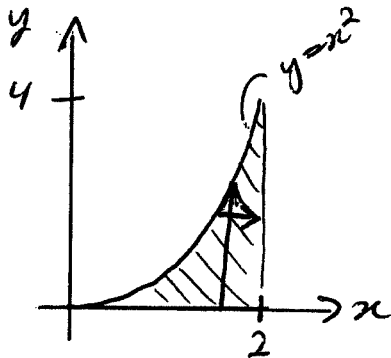

then  $y$  goes 0 to  $x^2$   
and  $x$  0 to 2

Thus

$$\int_0^4 \int_{\sqrt{y}}^2 \sqrt{x^3+1} \, dx \, dy$$

$$= \int_0^2 \int_0^{x^2} \sqrt{x^3+1} \, dy \, dx$$

$$= \int_0^2 \sqrt{x^3+1} (y \Big|_0^{x^2}) \, dx$$

$$= \int_0^2 x^2 \sqrt{x^3+1} \, dx$$

$$= \frac{2}{9} (x^3+1)^{3/2} \Big|_0^2$$

$$= \frac{2}{9} ((9)^{3/2} - 1) = \frac{2}{9} (27-1) = \boxed{\frac{52}{9}} \approx \boxed{5.78}$$

(A)

5

4. Compute the volume of the solid bounded by the paraboloid  $z = x^2 + y^2$  and the plane  $z = 4$ .

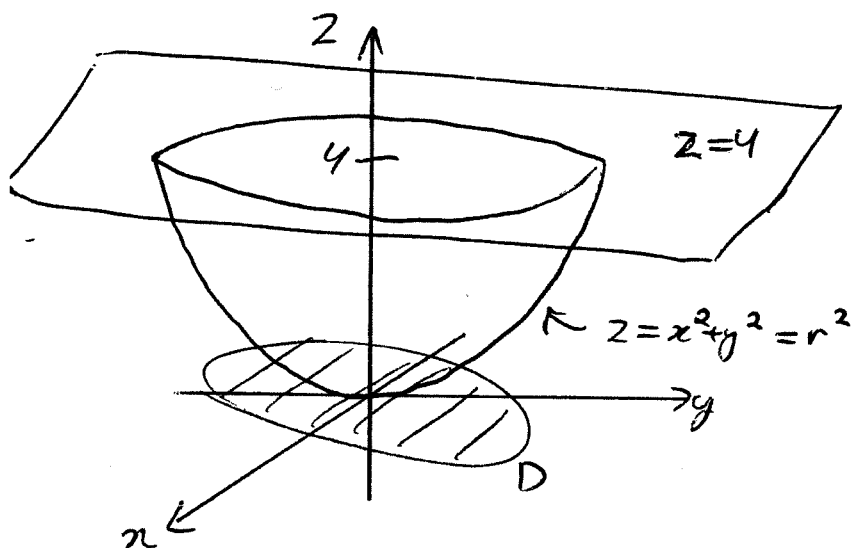

shadow on  $xy$  plane  
is disk  $x^2 + y^2 \leq 4$

use polar coords

So Volume is

$$\begin{aligned} V &= \int_0^{2\pi} \int_0^2 (4 - r^2) r \, dr \, d\theta \\ &= 2\pi \int_0^2 (4r - r^3) \, dr \\ &= 2\pi \left( 2r^2 - \frac{1}{4}r^4 \Big|_0^2 \right) \\ &= 2\pi (8 - 4) \\ &= \boxed{8\pi} \approx \boxed{25.13} \end{aligned}$$

(A)

6

5. Calculate the total mass of the tetrahedron which is in the first octant and under the plane  $x + y + z = 1$  where the density function is  $\rho(x, y, z) = x$ .

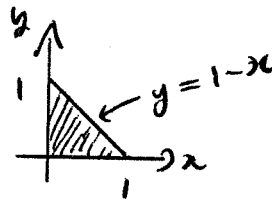
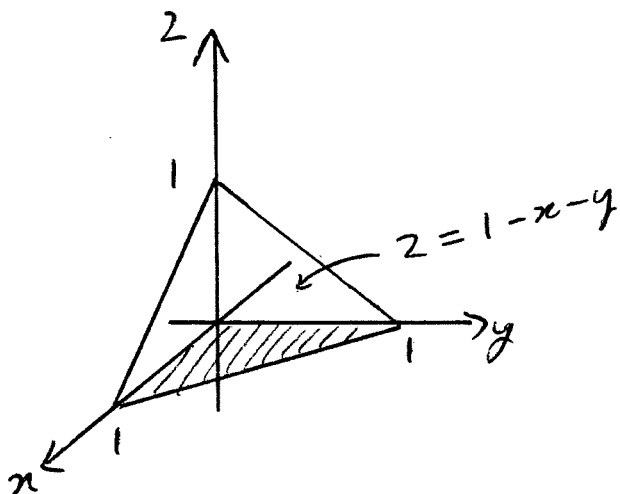

The mass is  $M = \int_0^1 \int_0^{1-x} \int_0^{1-x-y} x \, dz \, dy \, dx$

$$= \int_0^1 \int_0^{1-x} x \left( z \Big|_0^{1-x-y} \right) dy \, dx$$

$$= \int_0^1 \int_0^{1-x} (x - x^2 - xy) dy \, dx$$

$$= \int_0^1 \left( (x - x^2) - \frac{1}{2}xy^2 \Big|_0^{1-x} \right) dx$$

$$= \int_0^1 \left( (x - x^2)(1-x) - \frac{1}{2}x(1-x)^2 \right) dx$$

$$= \int_0^1 \frac{1}{2}x(1-x)^2 dx$$

$$= \frac{1}{2} \int_0^1 (x - 2x^2 + x^3) dx$$

$$= \frac{1}{2} \left( \frac{1}{2}x^2 - \frac{2}{3}x^3 + \frac{1}{4}x^4 \Big|_0^1 \right)$$

$$= \frac{1}{2} \left( \frac{1}{2} - \frac{2}{3} + \frac{1}{4} \right) = \frac{1}{2} \left( \frac{6 - 8 + 3}{12} \right) = \boxed{\frac{1}{24}} \approx \boxed{0.042}$$

(B)

MAT 2322 D Winter 2016. February 25th, 14:30 Prof. Desjardins

TEST #1

Max = 20

Name: \_\_\_\_\_

Solutions

Student Number: \_\_\_\_\_

- Time: 80 min.
- Verify that your copy of the midterm has exactly 6 pages (including this one).
- There are 5 questions worth 4 marks each for a total of 20 points.
- Only basic scientific calculators are permitted: non-programmable, non-graphing.
- Work all problems in the space provided. Use the backs of the pages for rough work if necessary. Do not use any other paper.
- Cellular phones, unauthorized electronic devices or course notes are not allowed during this exam. Phones and devices must be turned off and put away in your bag. Do not keep them in your possession, such as in your pockets. If caught with such a device or document, the following may occur: you will be asked to leave immediately the exam, academic fraud allegations will be filed which may result in you obtaining a 0 (zero) for the exam. By signing below, you acknowledge that you have ensured that you are complying with the above statement.

Signature: \_\_\_\_\_

(B)

2

1. Find and classify the critical points of the following function.

$$f(x, y) = 2x^2 - x^2y + y^2$$

$$f_x = 4x - 2xy = 2x(2-y)$$

$$f_x = 0 \text{ if } x=0 \text{ or } y=2$$

$$f_y = -x^2 + 2y \quad f_y = 0 \text{ if } 2y = x^2$$

$$\text{if } x=0, y=0 \Rightarrow (0,0)$$

$$\text{if } y=2, x^2=4 \Rightarrow x=\pm 2 \Rightarrow (2,2) \text{ and } (-2,2)$$

$$f_{xx} = 4 - 2y, \quad f_{xy} = -2x, \quad f_{yy} = 2$$

$$D = (4 - 2y)(2) - (-2x)^2 = 8 - 4y - 4x^2$$

$$D(0,0) = 8 \quad f_{xx}(0,0) = 4 \Rightarrow \boxed{(0,0) \text{ local min}}$$

$$D(2,2) = -16 \Rightarrow \boxed{(2,2) \text{ saddle point}}$$

$$D(-2,2) = -16 \Rightarrow \boxed{(-2,2) \text{ saddle point}}$$

(B)

3

2. Use the method of Lagrange multipliers to determine the absolute minimum and maximum values of the function  $f(x, y) = x^2 - 4y + y^2$  on the circle  $x^2 + y^2 = 4$ .

$$f(x, y) = x^2 - 4y + y^2, \quad g(x, y) = x^2 + y^2 = 4$$

$$\nabla f = \lambda \nabla g \Rightarrow f_x = \lambda g_x \Rightarrow 2x = 2\lambda x$$

$\text{or } x = \lambda x \Rightarrow x = 0$

$$f_y = \lambda g_y \Rightarrow -4 + 2y = 2\lambda y$$

$\text{or } -2 + y = \lambda y \Rightarrow \lambda \neq 1$

$$\text{if } x = 0, \quad y^2 = 4 \Rightarrow y = \pm 2$$

have 2 points  $(0, 2)$  and  $(0, -2)$

$$f(0, 2) = -4$$

$$f(0, -2) = 12$$

$\therefore$   $\boxed{\text{min } -4}$  and  $\boxed{\text{max } 12}$

3. Calculate the following integral.

$$\int_0^1 \int_{\sqrt{x}}^1 \sqrt{y^3+3} dy dx$$

have to switch order of integration

y goes  $\sqrt{x}$  to 1, then x 0 to 1, so the region is

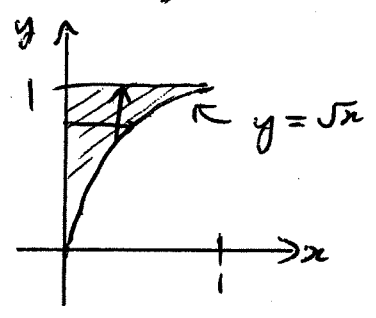

then x goes 0 to  $y^2$   
and y 0 to 1

thus  $\int_0^1 \int_{\sqrt{x}}^1 \sqrt{y^3+3} dy dx$

$$= \int_0^1 \int_0^{y^2} \sqrt{y^3+3} dx dy$$

$$= \int_0^1 \sqrt{y^3+3} (x|_0^{y^2}) dy$$

$$= \int_0^1 y^2 \sqrt{y^3+3} dy$$

$$= \frac{2}{9} (y^3+3)^{3/2} \Big|_0^1$$

$$= \frac{2}{9} (4^{3/2} - 3^{3/2}) = \boxed{\frac{2}{9} (8 - 3\sqrt{3})} \approx \boxed{0.62}$$

(B)

5

4. Compute the volume of the solid bounded from above by the hemisphere  $z = \sqrt{25 - x^2 - y^2}$  and from below by the plane  $z = 3$ .

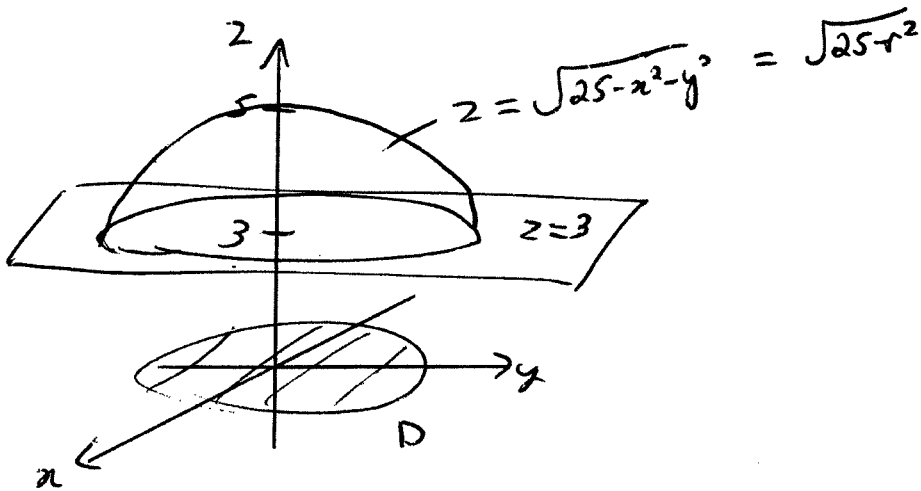

shadow on  $xy$  plane

is disk  $\sqrt{25 - (x^2 + y^2)} = 3$

or  $x^2 + y^2 \leq 16$

use polar coords

The volume is 
$$V = \int_0^{2\pi} \int_0^4 (\sqrt{25 - r^2} - 3) r dr d\theta$$

$$= 2\pi \int_0^4 (r\sqrt{25 - r^2} - 3r) dr$$

$$= 2\pi \left( -\frac{1}{3} (25 - r^2)^{3/2} - \frac{3}{2} r^2 \right) \Big|_0^4$$

$$= 2\pi \left( -\frac{1}{3} (9)^{3/2} - (25)^{3/2} - \frac{3}{2} (16) \right)$$

$$= 2\pi \left( -\frac{1}{3} (27 - 125) - 24 \right)$$

$$= 2\pi \left( \frac{98}{3} - 24 \right)$$

$$= \boxed{52\pi/3} \approx \boxed{54.45}$$

(B)

6

5. Calculate the total mass of the tetrahedron which is in the first octant and under the plane  $x + y + z = 2$  where the density function is  $\rho(x, y, z) = z$ .

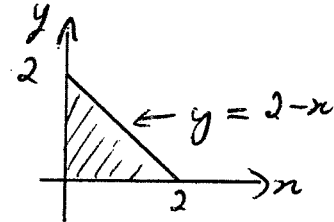
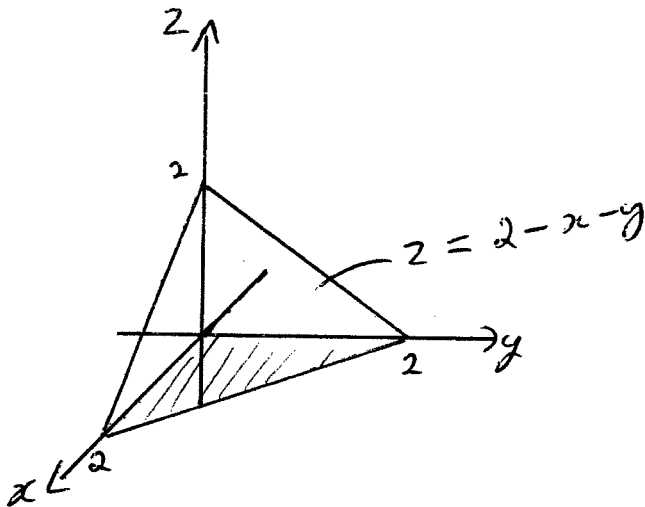

the mass is  $M = \int_0^2 \int_0^{2-x} \int_0^{2-x-y} z \, dz \, dy \, dx$

$$= \int_0^2 \int_0^{2-x} \left( \frac{1}{2} z^2 \Big|_0^{2-x-y} \right) dy \, dx$$

$$= \frac{1}{2} \int_0^2 \int_0^{2-x} (2-x-y)^2 dy \, dx$$

$$= \frac{1}{2} \int_0^2 \left( -\frac{1}{3} (2-x-y)^3 \Big|_0^{2-x} \right) dx$$

$$= -\frac{1}{6} \int_0^2 \left( (2-x - (2-x))^3 - (2-x)^3 \right) dx$$

$$= \frac{1}{6} \int_0^2 (2-x)^3 dx$$

$$= \frac{-1}{24} (2-x)^4 \Big|_0^2 = \frac{-1}{24} (0 - 16) = \boxed{\frac{2}{3}} \approx \boxed{0.67}$$