

EECE 376

Electromechanics: Module 2

Spring 2013, Instructor: Dr. Juri Jatskevich

Class Webpage: <http://courses.ece.ubc.ca/376/>

Electromechanical Energy Conversion (Read Chap. 2)

Learning Objectives, Important Topics and Concepts

- Basic electromechanical systems
- Electrical & mechanical inputs
- Losses in energy conversion
- Concept of coupling field, Energy & Co-Energy
- Graphical interpretation of energy conversion
- Electromechanical force and torque
- Multi input/output systems
- Torque in basic reluctance device
- Torque in basic rotating device with coupled circuits

1

Electromechanical Energy Conversion



2

Basic Electromechanical System

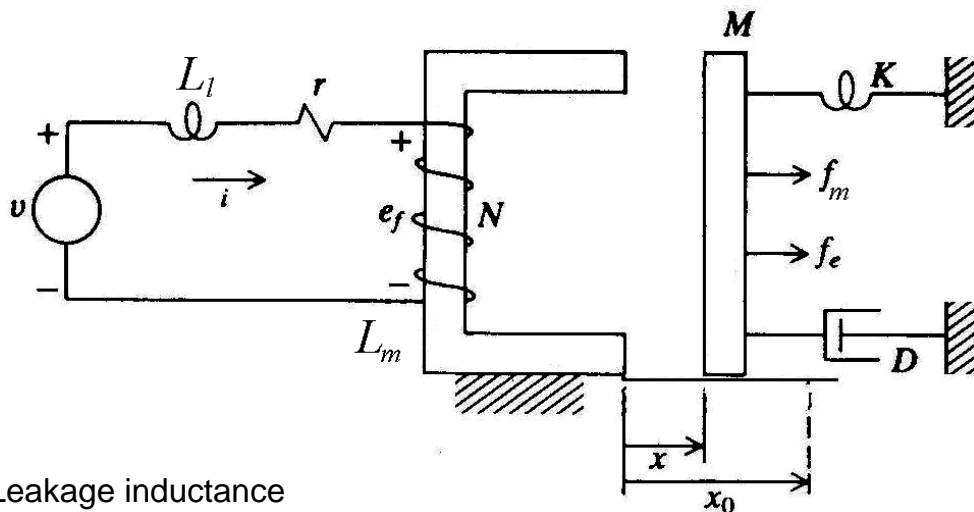

L_l - Leakage inductance

L_m - Magnetizing inductance

r - Coil resistance

e_f - EMF due to magnetizing inductance
(voltage drop due to coupling field)

v - Source voltage

i - Source current

M - Movable mass

K - Spring constant

D - Damping (coefficient)

f_m - External mech. force

f_e - Electromagnetic force

3

Electromechanical Energy Conversion

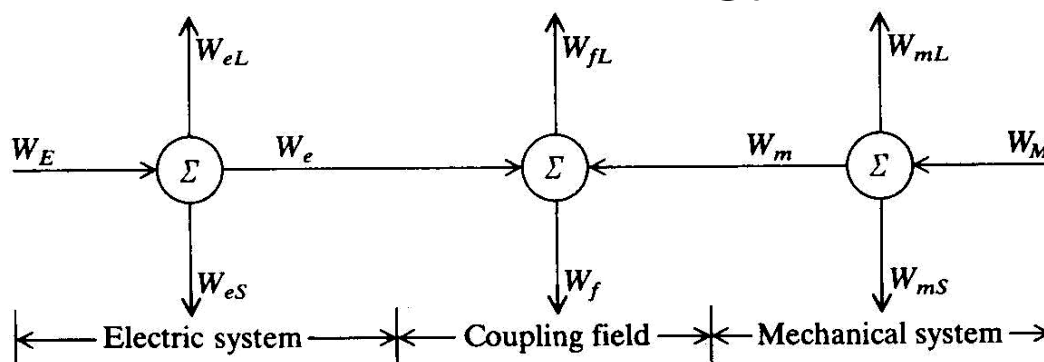

W_E - Energy from El. source

W_{eS} - Energy stored in El. system
(not coupled with Mech. sys.)

W_{eL} - Energy loss in El. system

W_e - Energy going in coupling field

W_{fL} - Energy loss in coupling field

W_M - Energy from Mech. source

W_{mS} - Energy stored in Mech. system
(not coupled with El. sys.)

W_{mL} - Energy loss in Mech. system

W_m - Energy going in coupling field

W_f - Energy in coupling field

4

Basic Electromechanical System

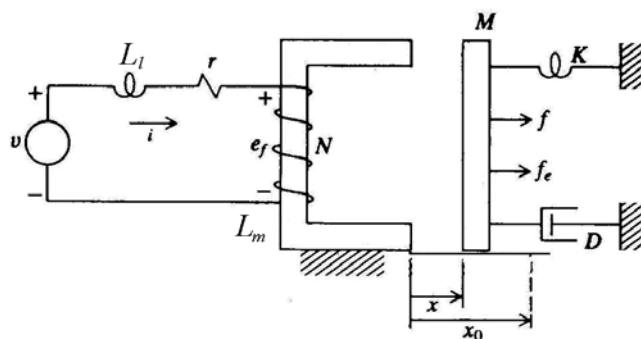

Electrical Side

$$v = ri + \frac{d\lambda}{dt}$$

$$\lambda = [L_l + L_m(x)]i$$

$$v = ri + L_l \frac{di}{dt} + \frac{d}{dt} [L_m(x)i] = ri + L_l \frac{di}{dt} + e_f$$

Energy from Electrical System

$$\begin{aligned} W_E &= \int P_e(t) dt = \int v i dt \\ &= r \int i^2 dt + L_l \int i \frac{di}{dt} dt + \int e_f i dt \end{aligned}$$

Energy going into coupling field

$$W_e = \int e_f i dt$$

5

Basic Electromechanical System

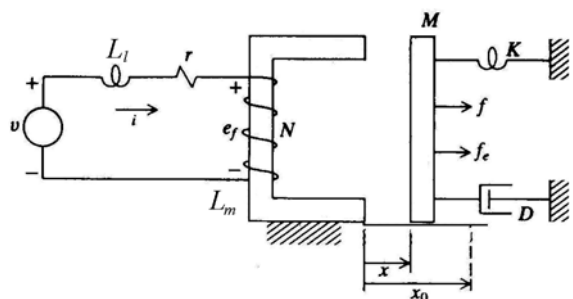

Mechanical Side

$$f_m + f_e = M \frac{d^2x}{dt^2} + D \frac{dx}{dt} + K(x - x_0)$$

Energy from Mechanical System

$$W_M = \int f_m dx = \int f_m \frac{dx}{dt} dt$$

$$W_M = M \int \frac{d^2x}{dt^2} dx + D \int \left(\frac{dx}{dt} \right)^2 dt + K \int (x - x_0) dx - \int f_e dx$$

Energy going into coupling field

$$W_m = - \int f_e dx$$

6

Basic Electromechanical System

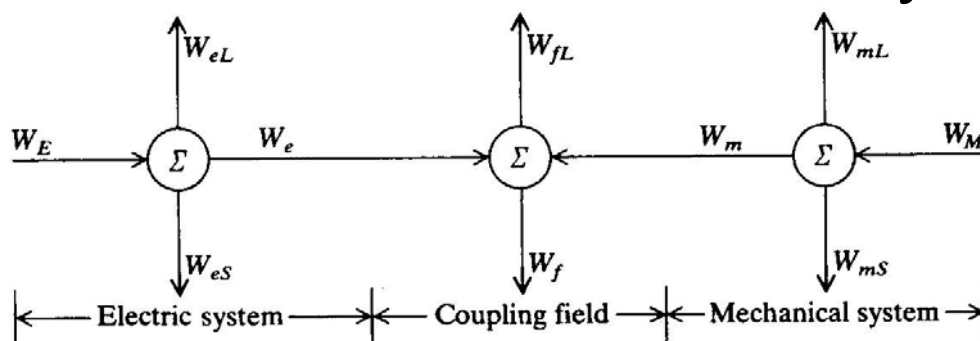

Neglect the losses in the coupling field

$$W_f = W_e + W_m$$

$$W_f = \int e_f i dt - \int f_e dx$$

How do you convert the energy ?

7

Energy in Coupling Field

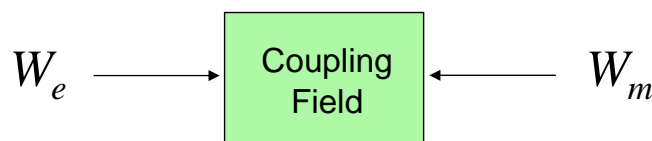

Energy going into coupling field

$$W_f = W_e + W_m = \int e_f i dt - \int f_e dx$$

Consider one input only, and assume $dx = 0$

$$W_f = \int e_f i dt = \int \frac{d\lambda}{dt} i dt = \int i d\lambda$$

8

Energy in Coupling Field

Consider a state of the system

$$i = i_a \quad \lambda = \lambda_a$$

Energy going in coupling field

$$W_f = \int id\lambda$$

Co-Energy associated with this state

$$W_c = \int \lambda di, \text{ assuming } dx = 0$$

Energy and Co-Energy Balance

$$\lambda i = W_f + W_c$$

Coupling Field is Conservative – The stored energy does not depend on the history of electromechanical variables, it depends only on their final state/values

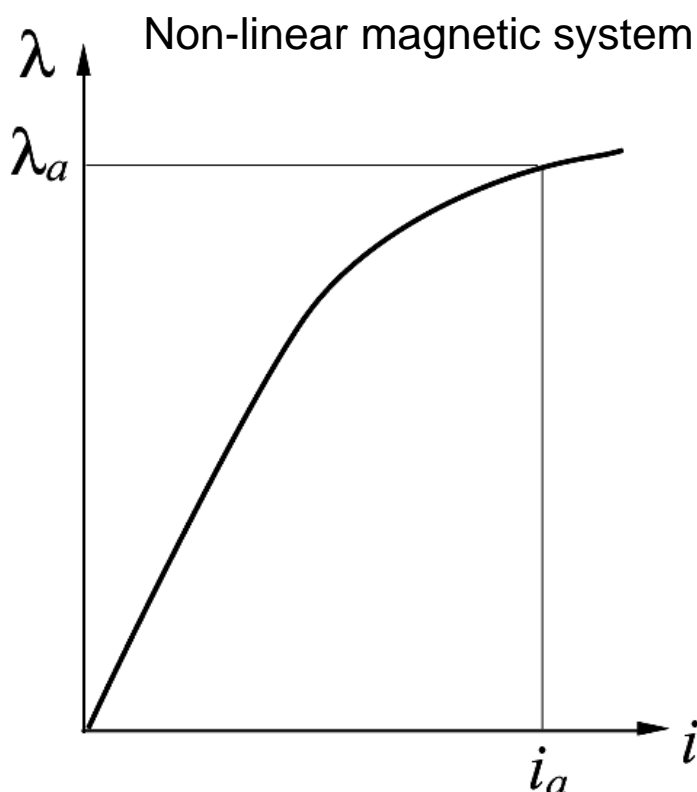

9

Energy in Coupling Field

Consider a state of the system

$$i = i_a \quad \lambda = \lambda_a$$

Energy going in coupling field

$$W_f = \int id\lambda$$

Co-Energy associated with this state

$$W_c = \int \lambda di, \text{ assuming } dx = 0$$

For magnetically linear systems

Energy and Co-Energy Balance

$$W_f = W_c = \frac{1}{2} \lambda i$$

Coupling Field is Conservative – The stored energy does not depend on the history of electromechanical variables, it depends only on their final state/values

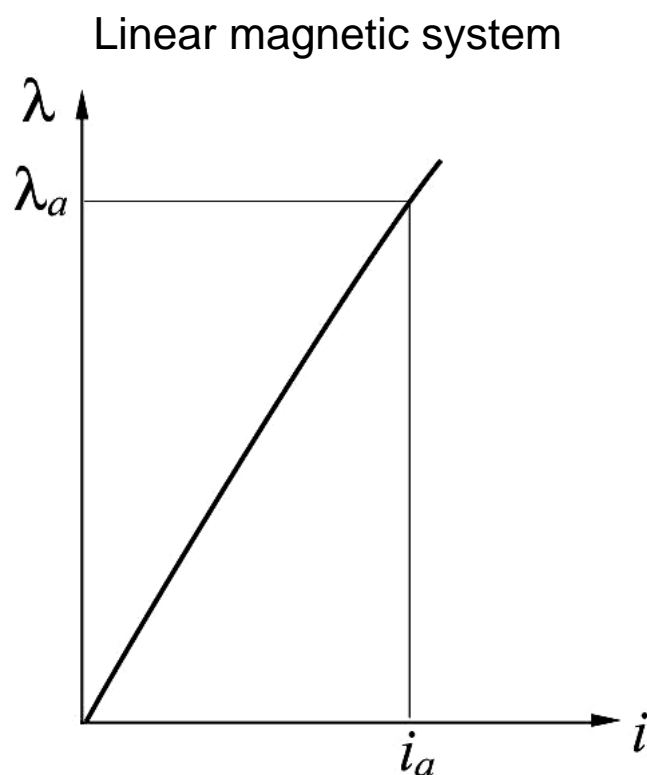

10

Energy & Co-Energy

Independent variables i, x

$$\lambda = \lambda(i, x)$$

Energy going in coupling field

$$W_f = \int id\lambda = W_f(i, x)$$

$$d\lambda = \frac{\partial \lambda}{\partial i} di + \frac{\partial \lambda}{\partial x} dx$$

assuming $dx = 0$

$$W_f = \int i \frac{\partial \lambda}{\partial i} di$$

Co-Energy $W_c = \int \lambda di$

Independent variables λ, x

$$i = i(\lambda, x)$$

Energy going in coupling field

$$W_f = \int id\lambda = W_f(\lambda, x)$$

$$W_f = \int i(\lambda, x) d\lambda$$

Co-Energy $W_c = \int \lambda di = W_c(\lambda, x)$

$$di = \frac{\partial i}{\partial \lambda} d\lambda + \frac{\partial i}{\partial x} dx$$

assuming $dx = 0$

$$W_c = \int \lambda \frac{\partial i}{\partial \lambda} d\lambda$$

Energy in Coupling Field

Consider linear magnetic system

$$\lambda = \lambda(i, x) = L(x)i \quad \text{or} \quad i = i(\lambda, x) = \frac{\lambda}{L(x)}$$

Energy going in coupling field $W_f = \int id\lambda$

assuming $dx = 0$ we get $d\lambda = L(x)di$

$$W_f = \int \frac{\lambda}{L(x)} d\lambda = \frac{1}{L(x)} \int_0^{\lambda_a} \lambda d\lambda = \frac{1}{2L(x)} \lambda_a^2 = \frac{1}{2} L(x) i_a^2$$

Co-Energy associated with this state

$$W_c = \int \lambda di = L(x) \int_0^{i_a} i di = \frac{1}{2} L(x) i_a^2$$

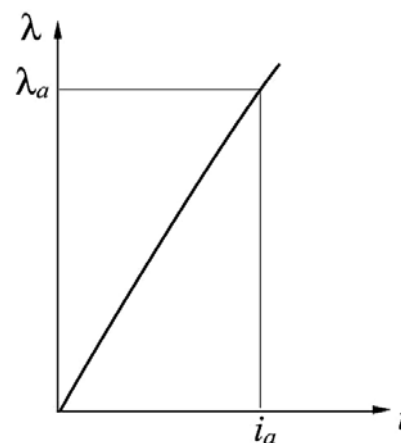

Electromechanical Energy Conversion

Graphical interpretation

Assume move from x_a to x_b

Consider $\lambda - i$ relationship

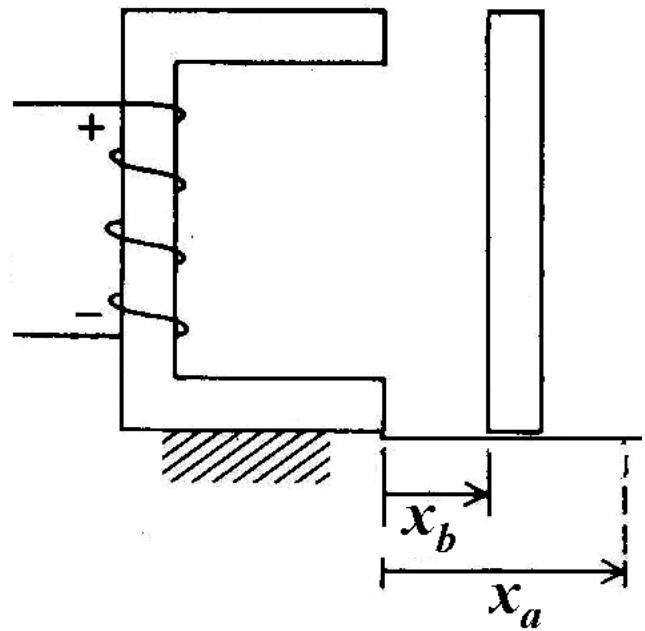
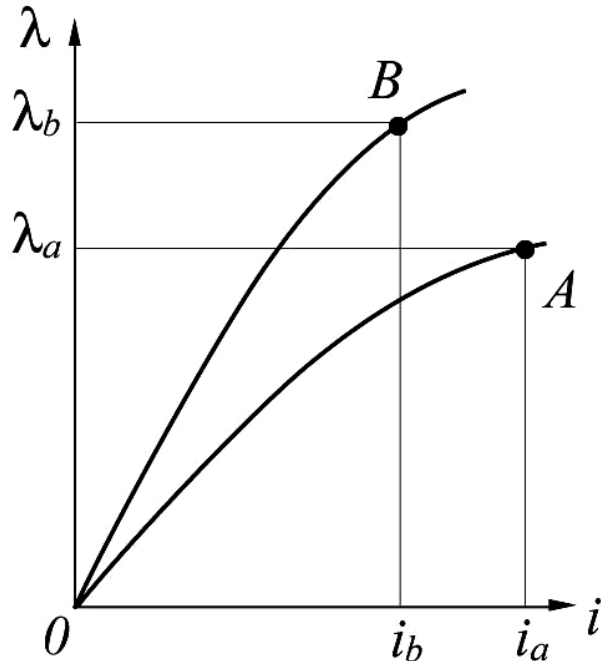

13

Change in Energy

State x_a

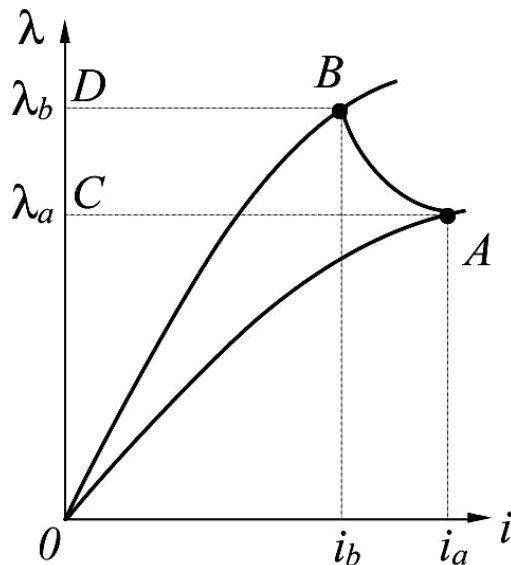

State x_b

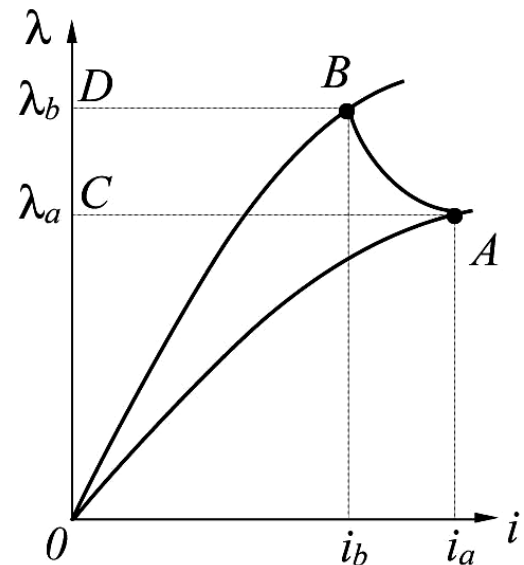

Coupling Field Energy $\Delta W_f = OBDO - OACO$

14

Change in Energy

Assume move from x_a to x_b

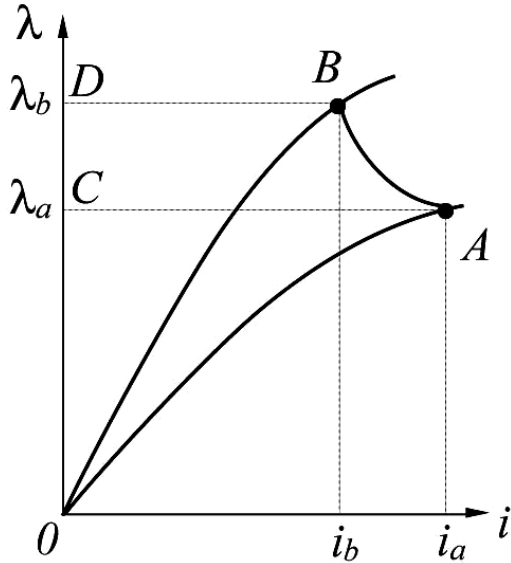

Change in electrical input

$$\Delta W_e = \int i e_f dt = \int_{\lambda_a}^{\lambda_b} i d\lambda = CABDC$$

Change in Energy

Change in mechanical input

$$\Delta W_m = \Delta W_f - \Delta W_e = OBDO - OACO - CABDC$$

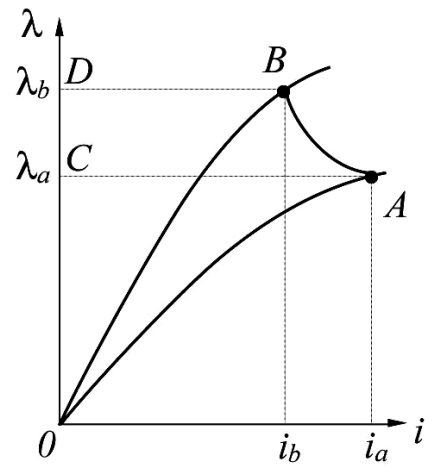
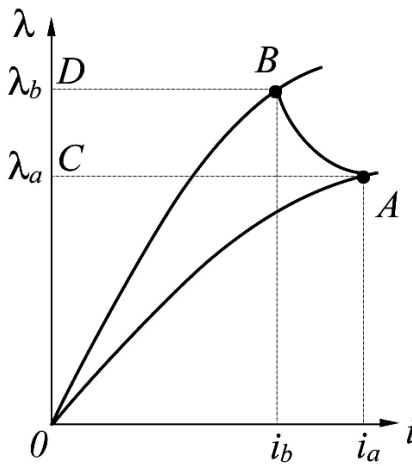
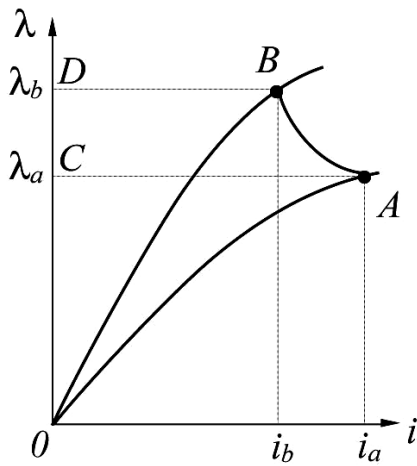

Balance of area

$$OBDO + OABO = OACO + CABDC$$

$$\Delta W_m =$$

Energy has been supplied to

Electromechanical Energy Conversion

Graphical interpretation

Assume move back from x_b to x_a

Consider $\lambda - i$ relationship

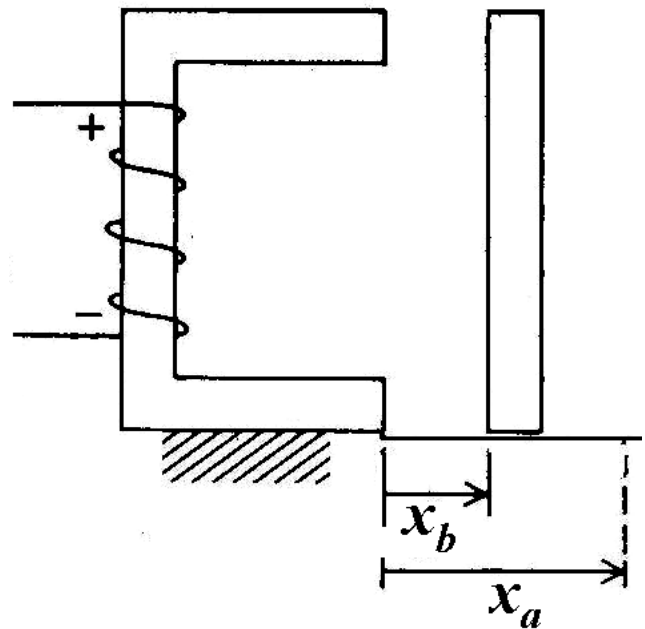
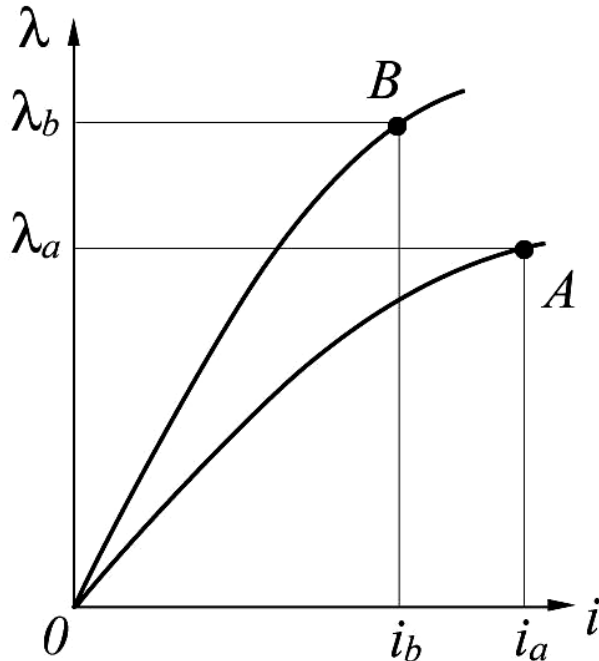

17

Change in Energy

Assume move from x_b to x_a

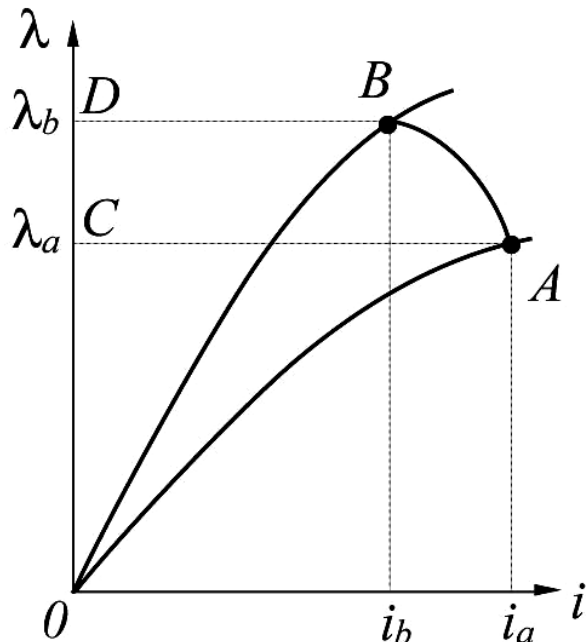

Coupling Field Energy

$$\Delta W_f = -OBDO + OACO$$

Change in electrical input

$$\Delta W_e = \int_{\lambda_b}^{\lambda_a} i d\lambda = -CABDC$$

Change in mechanical input

$$\begin{aligned} \Delta W_m &= \Delta W_f - \Delta W_e \\ &= OABO \end{aligned}$$

18

Change in Energy

Assume a cycle from x_a to x_b and back from x_b to x_a

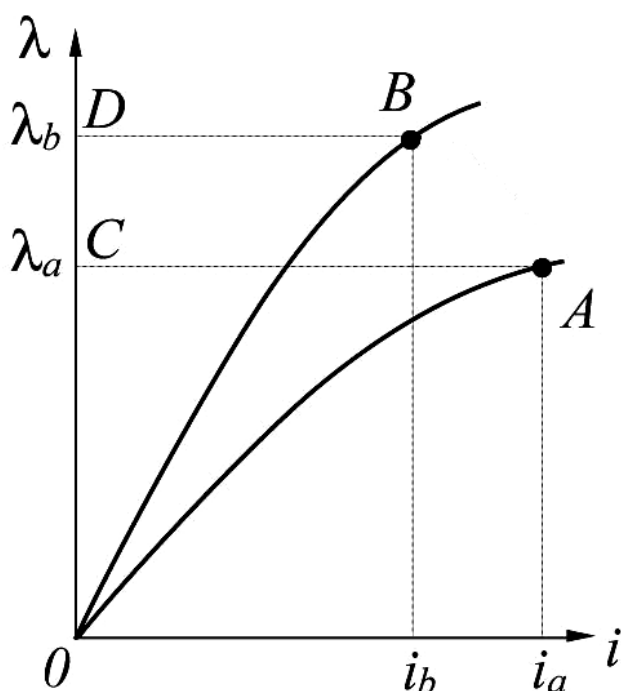

Coupling Field Energy

$$\Delta W_{f,cycle} =$$

Change in electrical input

$$\Delta W_{e,cycle} =$$

Change in mechanical input

$$\Delta W_{m,cycle} =$$

19

Electromagnetic Forces

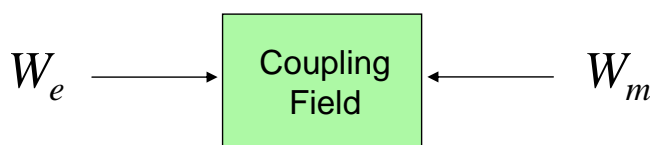

Energy going into coupling field $W_f = W_e + W_m = \int e_f idt - \int f_e dx$

Differential form $dW_f = e_f idt - f_e dx = id\lambda - f_e dx$

$$f_e dx = id\lambda - dW_f$$

$$d\lambda(i, x) = \frac{\partial \lambda}{\partial i} di + \frac{\partial \lambda}{\partial x} dx$$

$$dW_f(i, x) = \frac{\partial W_f}{\partial i} di + \frac{\partial W_f}{\partial x} dx$$

$$f_e dx = i \frac{\partial \lambda}{\partial i} di + i \frac{\partial \lambda}{\partial x} dx - \frac{\partial W_f}{\partial i} di - \frac{\partial W_f}{\partial x} dx$$

20

Electromagnetic Forces

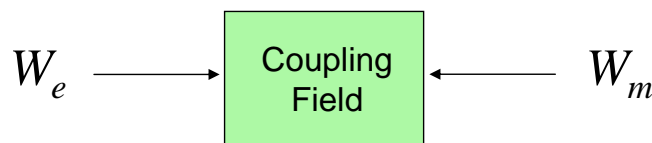

Differential form

$$f_e dx = id\lambda - dW_f = \left(i \frac{\partial \lambda}{\partial i} - \frac{\partial W_f}{\partial i} \right) di + \left(i \frac{\partial \lambda}{\partial x} - \frac{\partial W_f}{\partial x} \right) dx$$

Electromagnetic force $f_e(i, x) = i \frac{\partial \lambda}{\partial x} - \frac{\partial W_f}{\partial x}$

Recall Co-Energy $W_c(i, x) = \lambda i - W_f$ $\frac{\partial W_c}{\partial x} = \frac{\partial (\lambda i - W_f)}{\partial x}$

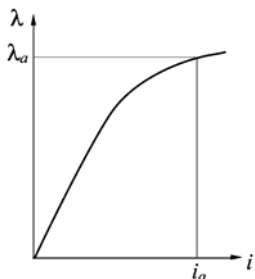

$$f_e(i, x) = \frac{\partial W_c}{\partial x}$$

21

Multi-Input Systems

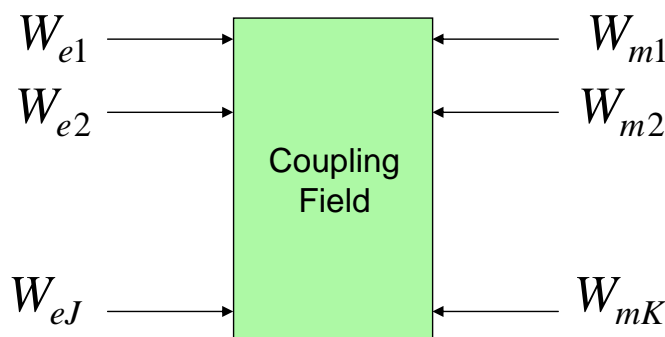

Energy going into coupling field $W_f = \sum_{j=1}^J W_{ej} + \sum_{k=1}^K W_{mk}$

$$W_{ej} = \int e_{ff} i_j dt$$

Contribution from j-th electrical input

$$W_{mk} = - \int f_{ek} dx_k$$

Contribution from k-th mechanical input

22

Practical Multi-Input Systems

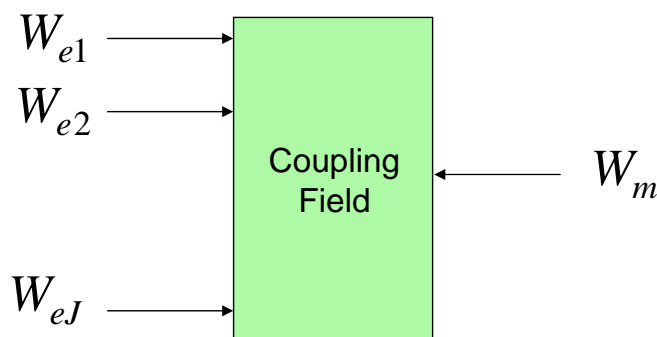

Energy going into coupling field

$$W_f = \sum_{j=1}^J W_{ej} + W_m = \int \sum_{j=1}^J e_{ff} i_j dt - \int f_e dx$$

Differential form

$$dW_f = \sum_{j=1}^J e_{ff} i_j dt - f_e dx$$

23

Multi-Input System: El. Mag. Forces

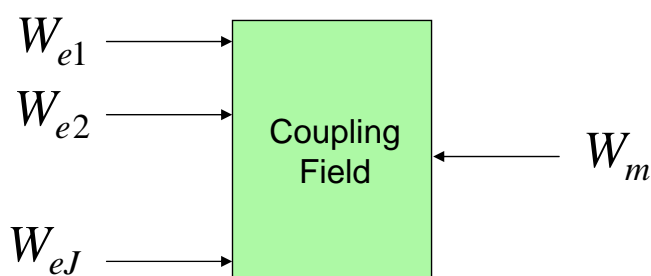

Differential form

$$f_e dx = \sum_{j=1}^J i_j d\lambda_j - dW_f$$

$$W_f(i_1, i_2, \dots, i_J; x) = W_f(\mathbf{i}, x)$$

$$\lambda_j(i_1, i_2, \dots, i_J; x) = \lambda_j(\mathbf{i}, x)$$

Force

$$f_e(\mathbf{i}, x) = \sum_{j=1}^J i_j \frac{\partial \lambda_j}{\partial x} - \frac{\partial W_f}{\partial x}$$

Recall Co-Energy

$$W_c(\mathbf{i}, x) = \sum_{j=1}^J \lambda_j i_j - W_f$$

$$\frac{\partial W_c(\mathbf{i}, x)}{\partial x} = \sum_{j=1}^J i_j \frac{\partial \lambda_j}{\partial x} - \frac{\partial W_f}{\partial x}$$

$$f_e(\mathbf{i}, x) = \frac{\partial W_c}{\partial x}$$

24

Energy in Coupling Field

Consider system with 2 elec. inputs

Energy going into coupling field

$$W_f = \int \sum_{j=1}^J i_j d\lambda_j = \int (i_1 d\lambda_1 + i_2 d\lambda_2)$$

assuming $dx = 0$

$$W_f = \int \left[i_1 \left(\frac{\partial \lambda_1}{\partial i_1} di_1 + \frac{\partial \lambda_1}{\partial i_2} di_2 \right) + i_2 \left(\frac{\partial \lambda_2}{\partial i_1} di_1 + \frac{\partial \lambda_2}{\partial i_2} di_2 \right) \right]$$

Assume 2-step procedure:

Step-1: set $i_2 = 0 = \text{const}$, increase i_1

Step-2: set $i_1 = \text{const.}$, ($di_1 = 0$), increase i_2

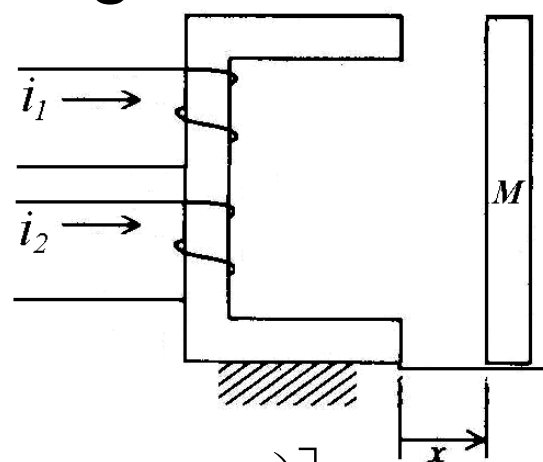

25

Energy in Coupling Field

System with 2 electrical inputs:

$$W_f = \int \left[i_1 \left(\frac{\partial \lambda_1}{\partial i_1} di_1 + \frac{\partial \lambda_1}{\partial i_2} di_2 \right) + i_2 \left(\frac{\partial \lambda_2}{\partial i_1} di_1 + \frac{\partial \lambda_2}{\partial i_2} di_2 \right) \right]$$

Assume 2-step procedure:

Step-1: set $i_2 = 0 = \text{const}$,
increase i_1

$$W_{f, \text{step-1}} = \int i_1 \frac{\partial \lambda_1}{\partial i_1} di_1$$

Step-2: set $di_1 = 0$,
increase i_2

$$W_{f, \text{step-2}} = \int \left[i_1 \frac{\partial \lambda_1}{\partial i_2} di_2 + i_2 \frac{\partial \lambda_2}{\partial i_2} di_2 \right]$$

$$W_f = W_{f, \text{step-1}} + W_{f, \text{step-2}}$$

26

Energy in Coupling Field

System with 2 electrical inputs:

$$W_f = \int \left[i_1 \frac{\partial \lambda_1}{\partial i_1} di_1 + i_1 \frac{\partial \lambda_1}{\partial i_2} di_2 + i_2 \frac{\partial \lambda_2}{\partial i_2} di_2 \right]$$

Assume flux linkages

$$\lambda_1 = L_{11}(x)i_1 + L_{12}(x)i_2 \quad d\lambda_1 = L_{11}(x)di_1 + L_{12}(x)di_2$$

$$\lambda_2 = L_{22}(x)i_2 + L_{21}(x)i_1 \quad d\lambda_2 = L_{22}(x)di_2 + L_{21}(x)di_1$$

$$W_f = \int_0^{i_1} i_1 L_{11} di_1 + \int_0^{i_2} (i_1 L_{12} + i_2 L_{22}) di_2 = \frac{1}{2} L_{11} i_1^2 + L_{12} i_1 i_2 + \frac{1}{2} L_{22} i_2^2$$

27

Energy in Coupling Field

System with 2 electrical inputs: $W_f = \frac{1}{2} L_{11} i_1^2 + L_{12} i_1 i_2 + \frac{1}{2} L_{22} i_2^2$

System with J electrical inputs:

$$\lambda_j = L_{j1} i_1 + L_{j2} i_2 + \dots + L_{jJ} i_J$$

$$d\lambda_j = L_{j1} di_1 + L_{j2} di_2 + \dots + L_{jJ} di_J$$

$$W_f = \frac{1}{2} \sum_{i=1}^J \sum_{j=1}^J L_{ij} i_i i_j$$

In Matrix Form

$$\begin{bmatrix} \lambda_1 \\ \vdots \\ \lambda_J \end{bmatrix} = \begin{bmatrix} L_{11} & \cdots & L_{1J} \\ \vdots & \ddots & \vdots \\ L_{J1} & \cdots & L_{JJ} \end{bmatrix} \begin{bmatrix} i_1 \\ \vdots \\ i_J \end{bmatrix}$$

$$W_f = \frac{1}{2} \mathbf{i}^T \mathbf{L} \mathbf{i}$$

$$\boldsymbol{\lambda} = \mathbf{L} \mathbf{i}$$

28

Electromagnetic Forces & Torques

Linear Devices

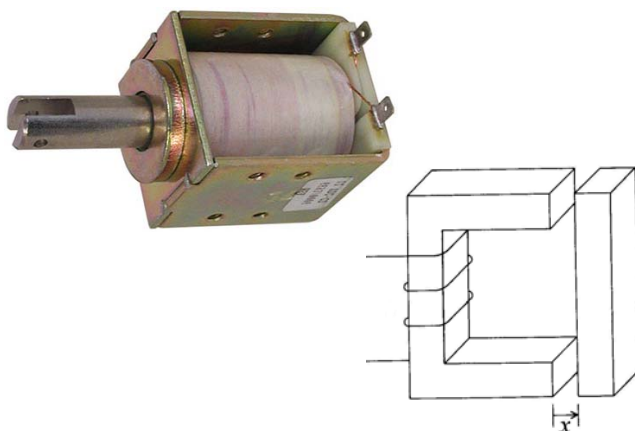

Mech. Energy going into coupling field

$$W_m = -\int f_e dx$$

Electromagnetic Force f_e

$$dW_m = -f_e dx$$

Rotating Devices

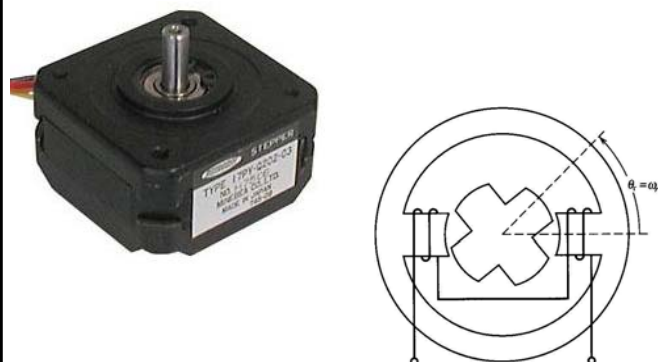

Mech. Energy going into coupling field

$$W_m = -\int T_e d\theta$$

Electromagnetic Torque T_e

$$dW_m = -T_e d\theta$$

29

Electromagnetic Forces & Torques

Linear Devices

$$f_e(\mathbf{i}, x) = \sum_{j=1}^J i_j \frac{\partial \lambda_j}{\partial x} - \frac{\partial W_f}{\partial x}$$

$$W_c(\mathbf{i}, x) = \sum_{j=1}^J \lambda_j i_j - W_f$$

$$f_e(\mathbf{i}, x) = \frac{\partial W_c}{\partial x}$$

$$f_e(\boldsymbol{\lambda}, x) = -\frac{\partial W_f}{\partial x}$$

$$f_e(\boldsymbol{\lambda}, x) = -\sum_{j=1}^J \lambda_j \frac{\partial i_j}{\partial x} + \frac{\partial W_c}{\partial x}$$

Rotating Devices

$$T_e(\mathbf{i}, \theta) = \sum_{j=1}^J i_j \frac{\partial \lambda_j}{\partial \theta} - \frac{\partial W_f}{\partial \theta}$$

$$W_c(\mathbf{i}, \theta) = \sum_{j=1}^J \lambda_j i_j - W_f$$

$$T_e(\mathbf{i}, \theta) = \frac{\partial W_c}{\partial \theta}$$

$$T_e(\boldsymbol{\lambda}, \theta) = -\frac{\partial W_f}{\partial \theta}$$

$$T_e(\boldsymbol{\lambda}, \theta) = -\sum_{j=1}^J \lambda_j \frac{\partial i_j}{\partial \theta} + \frac{\partial W_c}{\partial \theta}$$

30

Example 1 (2A in the Book)

Linear Devices

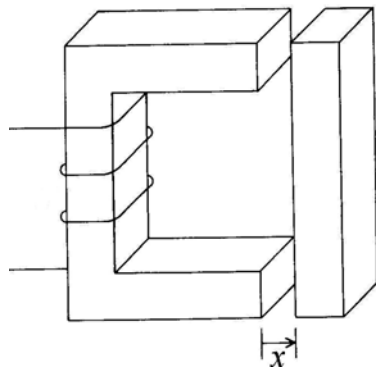

Total flux linkage

$$\lambda(i, x) = Li = [L_l + L_m(x)]i = \left(L_l + \frac{k}{x} \right) i$$

Flux linkage in the coupling field

$$\lambda_c(i, x) = L_m(x) \cdot i = \left(\frac{k}{x} \right) i$$

Calculate $f_e(i, x)$

$$W_c(i, x) = \int \lambda di = \int_0^{i_a} L_m i di = \frac{1}{2} \left(\frac{k}{x} \right) i^2$$

$$f_e(i, x) = \frac{\partial W_c}{\partial x} = \frac{1}{2} i^2 \frac{\partial L}{\partial x} = -\frac{1}{2} i^2 \frac{k}{x^2}$$

31

1-phase Reluctance Rotating Device

Consider as -winding

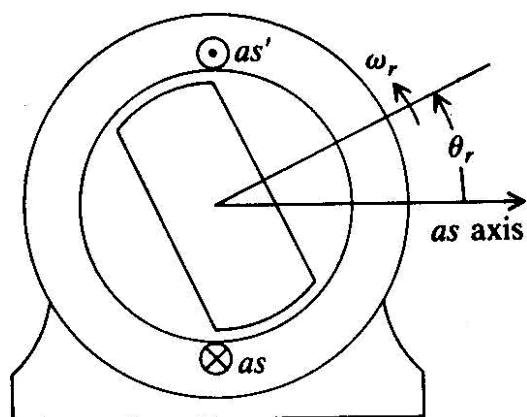

Voltage equation $v_{as} = r_s i_{as} + \frac{d\lambda_{as}}{dt}$

Flux linkage $\lambda_{as} = L_{asas} i_{as}$

Approximation of Magnetizing Inductance

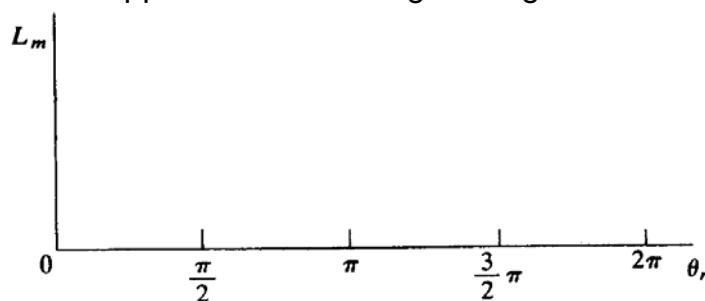

Self-Inductance $L_{asas} = L_{ls} + L_m(\theta_r) = L_{ls} + L_A - L_B \cos(2\theta_r)$

32

1-phase Reluctance Rotating Device

Consider as -winding

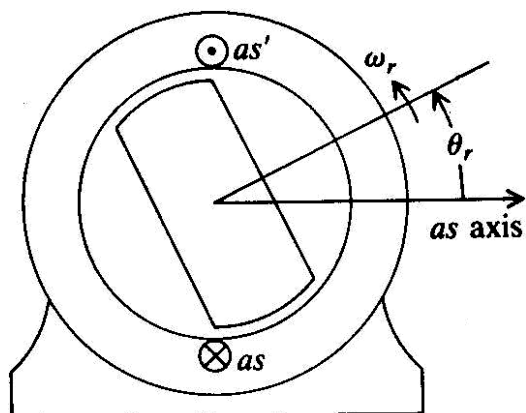

Let the rotor rotate $\theta_r = \theta_r(0) + \int_0^t \omega_r dt$

Flux linkage $\lambda_{as} = L_{asas} i_{as}$

Assume magnetically linear system

$$W_c = W_f = \frac{1}{2} L_m i_{as}^2$$

$$W_c(i_{as}, \theta_r) = \frac{1}{2} [L_A - L_B \cos(2\theta_r)] i_{as}^2$$

Electromagnetic Torque $T_e(i, \theta) = \frac{\partial W_c}{\partial \theta_r} = L_B i_{as}^2 \sin(2\theta_r)$

For constant current

33

1-phase Reluctance Rotating Device

Consider as -winding, let the rotor rotate $\theta_r = \theta_r(0) + \int_0^t \omega_r dt$

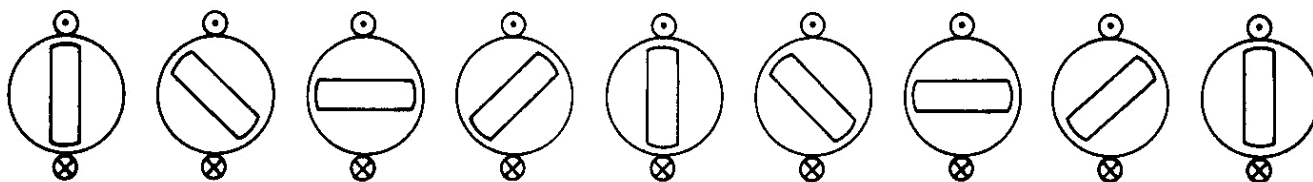
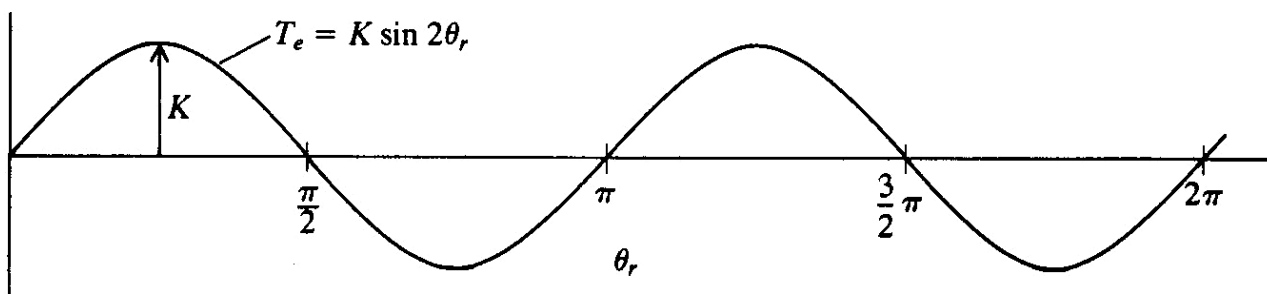

Which positions are stable ?

What is the average torque over a complete cycle ?

34

1-phase Reluctance Rotating Device

Consider as -winding, apply sinusoidal excitation

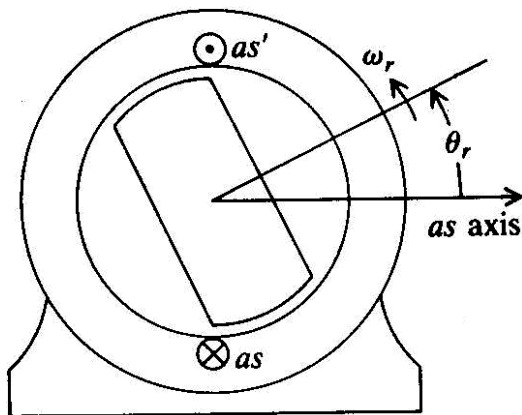

$$i_{as} = \sqrt{2} \cdot I_{s,rms} \cos(\theta_e)$$

$$\theta_e = \theta_e(0) + \int_0^t \omega_e dt = \theta_e(0) + \omega_e t$$

Assuming
$$\theta_r = \theta_r(0) + \int_0^t \omega_r dt$$

Electromagnetic Torque

$$T_e = 2I_{s,rms}^2 L_B \cos(\theta_e) \cos(\theta_r) \sin(2\theta_r)$$

$$= I_{s,rms}^2 L_B \cos(\theta_e) \frac{1}{2} [\sin(2\theta_r + \theta_e) + \sin(2\theta_r - \theta_e)]$$

$$T_e = I_{s,rms}^2 L_B \left[\sin(2\theta_r) + \frac{1}{2} \sin(2\theta_r + \theta_e) + \frac{1}{2} \sin(2\theta_r - \theta_e) \right]$$

35

Windings in Relative Motion

Stator & Rotor Windings

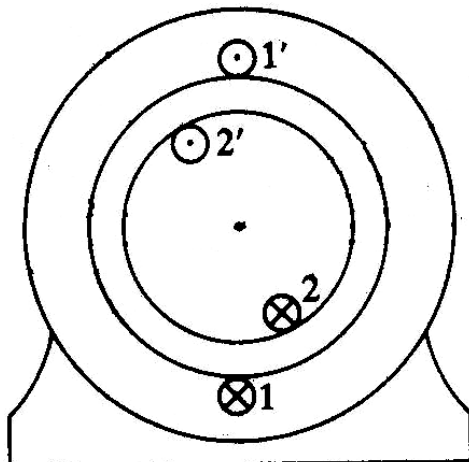

Voltage Equations

$$\begin{bmatrix} v_1 \\ v_2 \end{bmatrix} = \begin{bmatrix} r_1 & \\ & r_2 \end{bmatrix} \begin{bmatrix} i_1 \\ i_2 \end{bmatrix} + \frac{d}{dt} \begin{bmatrix} \lambda_1 \\ \lambda_2 \end{bmatrix}$$

Flux linkages

$$\begin{bmatrix} \lambda_1 \\ \lambda_2 \end{bmatrix} = \begin{bmatrix} L_{l1} + L_{m1} & L_{sr} \cos(\theta_r) \\ L_{sr} \cos(\theta_r) & L_{l2} + L_{m2} \end{bmatrix} \begin{bmatrix} i_1 \\ i_2 \end{bmatrix}$$

In Matrix Form
$$\mathbf{v} = \mathbf{r}\mathbf{i} + \frac{d\boldsymbol{\lambda}}{dt} \quad \boldsymbol{\lambda} = \mathbf{L}(\theta_r)\mathbf{i}$$

Assume magnetically linear system, we can express the Co-Energy

$$W_c(\mathbf{i}, \theta) = W_f(\mathbf{i}, \theta) = \frac{1}{2} \mathbf{i}^T \mathbf{L} \mathbf{i} = \frac{1}{2} L_{11} i_1^2 + L_{12} i_1 i_2 + \frac{1}{2} L_{22} i_2^2$$

36

Windings in Relative Motion

Electromagnetic Torque $T_e(\mathbf{i}, \theta) = \frac{\partial W_c}{\partial \theta} = -i_1 i_2 L_{sr} \sin(\theta_r)$

For constant currents i_1 and i_2

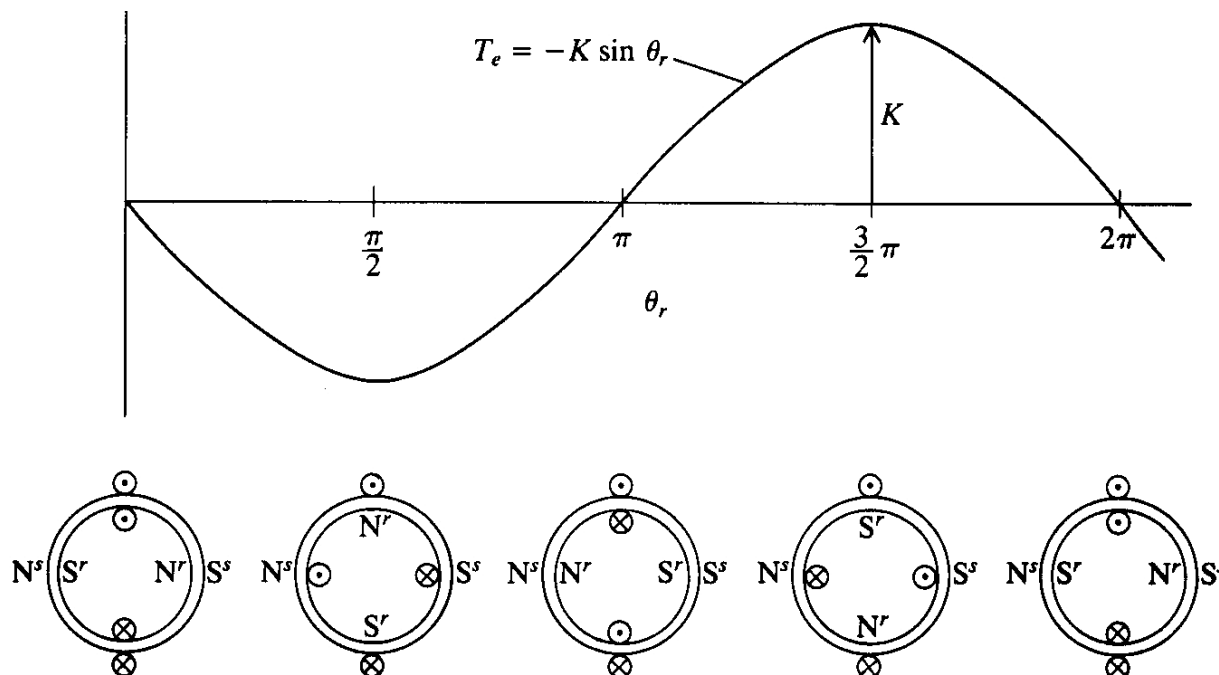

37

Example 2 (SP2.8-1)

Given: $L_{sr} = 0.1H$; $i_1 = 2A$; $i_2 = 10A$

a) Calculate Electromagnetic Torque

$$T_e = -i_1 i_2 L_{sr} \sin(\theta_r) = -2 \sin(\theta_r)$$

b) Assume applied external torque

$$T_m = 1N(\text{clockwise})$$

Calculate steady-state θ_r

$$\text{For steady-state } T_e = T_m = 1N$$

$$1 = -2 \sin(\theta_r); \quad \theta_r = \arcsin(-0.5) = -30^\circ$$

c) Assume applied external torque

$$T_m = 2N(\text{clockwise})$$

$$\text{For steady-state } 2 = -2 \sin(\theta_r); \quad \theta_r = \arcsin(-1) = -90^\circ$$

38