

EECE 376

Electromechanics

Spring 2015

Instructor: Dr. Juri Jatskevich

My Webpage: www.ece.ubc.ca/~jurij

Class Webpage:

<http://courses.ece.ubc.ca/376/>

Credit: 3-lecture-hour/week + 5 labs

1

Major Topics Covered

EECE 376, S-15, M-1

- Principles of electromagnetics, inductance and reluctance (2 lectures)
- Magnetic circuits & magnetically coupled systems (3 lectures)
- Linear and rotating electromechanical devices (4 lectures)
- Electromechanical energy conversion, concept of co-energy, developed forces and torques (5 lectures)
- Brushed dc motors, operation, equivalent circuit (4 lectures)
- DC motor dynamics and drive circuits, one-, two-, and four-quadrant operation (1 lectures)
- Stepper motors, principle of operation, full-step, micro-stepping, driver circuits (4 lectures)
- Rotating magnetic field, poly-phase systems (1 lectures)
- Synchronous motor, operation, dynamic & steady-state equivalent circuit, modelling (5 lectures)
- Brushless dc motors, operation, steady-state and dynamics, modelling (4 lectures)
- Induction motor, operation, equivalent circuit (5 lectures)
- Single phase AC motors (1 lecture)

2

Laboratory Experiments

Lab-0: Lab Equipment and Safety Rules

- There will be a safety instruction and a quiz!

Lab-1: Linear Solenoid Actuators

- 24V dc solenoid, principles of electromechanical energy conversion
- inductance and force vs. plunger positions and current values
- magnetic nonlinearities, hysteresis

Lab-2: Brushed DC Motors

- ¼ HP 48V Permanent Magnet DC Motor
- resistance, inductance, friction, torque constant, moment of inertia, etc
- performance & efficiency under load

Lab-3: Permanent Magnet Stepper Motors

- torque & inductance vs. position
- full, half, and micro-step operation
- effect of inductance on speed
- electromechanical resonance

Lab-4: Permanent Magnet Synchronous and Brushless DC Motors

- 210W 36V permanent magnet synchronous motor
- brushless dc motors, drive circuits, etc.

Lab-5: Induction Motors & Variable Frequency Drives

- industrial ¼ HP 34V Induction Motor,
- resistance, inductance, developed torque, performance & efficiency under load

3

Key Approach

$$J_t \frac{d\omega_{rm}}{dt} = T_e - T_{fric} - T_m$$

$$\mathbf{v}_{abc} = \mathbf{r}_s \mathbf{i}_{abc} + \frac{d\mathbf{\lambda}_{abc}}{dt}$$

$$T_e = \frac{P}{2} \cdot \frac{\partial W_c(\mathbf{i}, \theta_r)}{\partial \theta_r}$$

Theoretical fundamentals of electromechanical Actuators and Motors

Modelling as a tool for analysis and predicting the system behavior – modern design approach !

Lab Experiments – interaction with real devices, verification of the theory and models, hands-on engineering

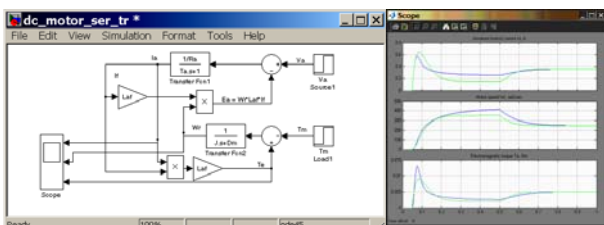
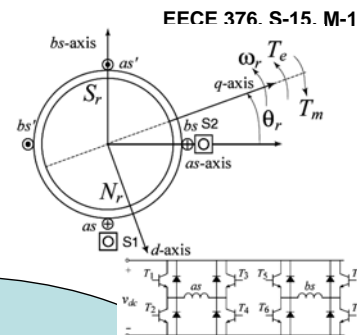

Modelling and simulation is part of design/synthesis process!

4

Electromechanics Applications:

- Generation of Electricity – Big Scale

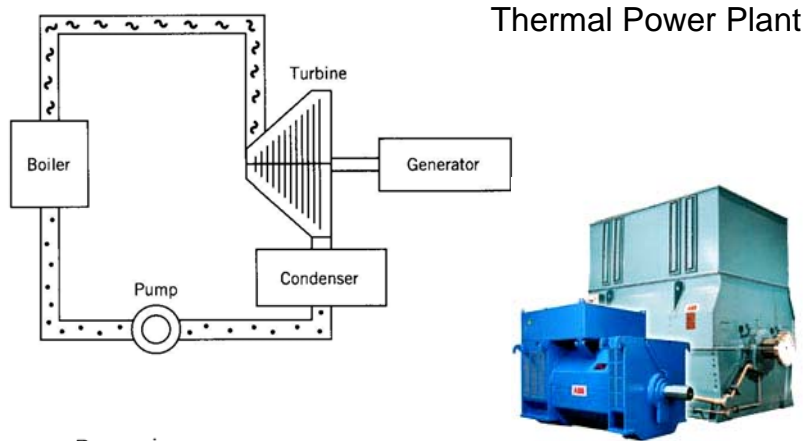
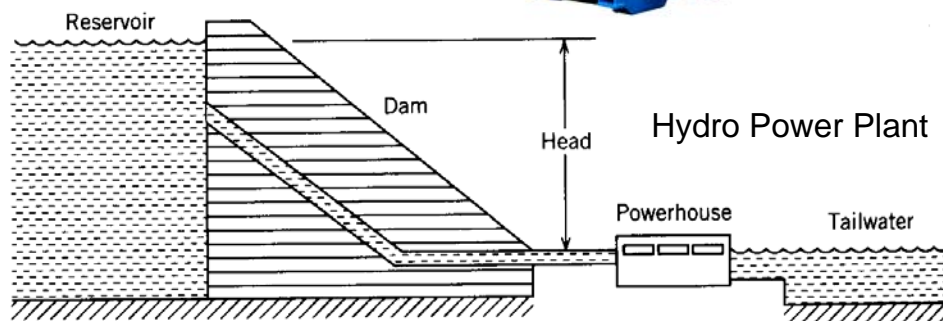

figure. King Mountain Wind Range, consisting of 214 1.3-MW wind turbines in Upton County, West Texas. (Courtesy: Bonus Energy Systems A/S.)

Wind Power



Electromechanical Devices

- Manufacturing
- Automotive
- Aircraft
- Ships
- Computers
- Office
- Household
- ...

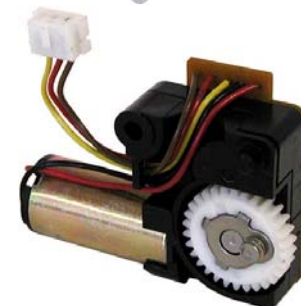

Electromechanical Applications:



EECE 376, S-15, M-1

Electromechanical Energy Conversion

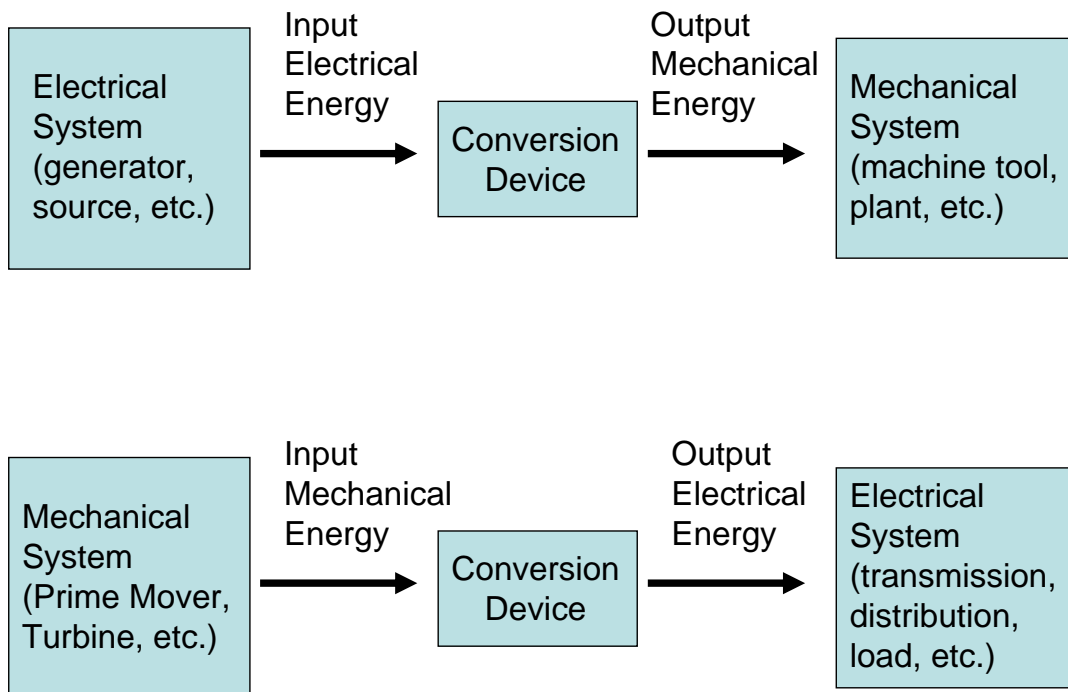

Electromechanical Energy Conversion

- Transformation of Electrical Energy

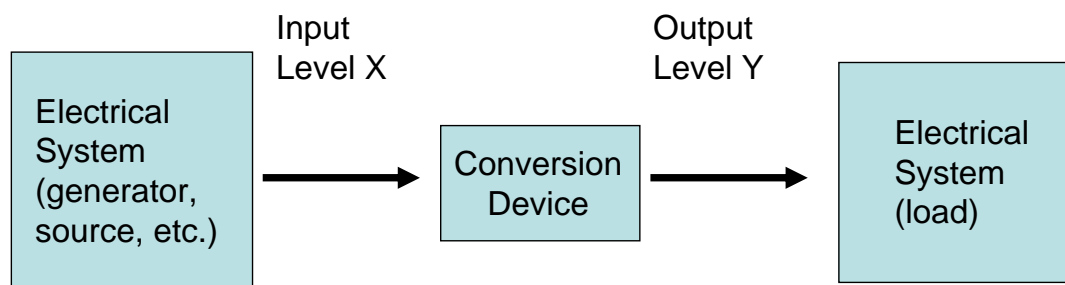

9

Electromechanical Energy Conversion

- Electrical Machines

- Stationary
 - Transformers
- Rotating
 - Motors, generators
- Linear Devices
 - Solenoids, linear motors, other actuators

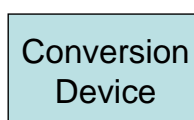

- Power Electronics (Switched Mode , SMPSs, Motor & Actuator Drivers, ...)

- Rectifiers
 - AC to DC
- Converters
 - DC to DC
- Inverters
 - DC to AC

Very broad & interesting area, requires its own course!

10

Module 1, Part 1

Review of AC Circuits, Phasors, 3-Phase (Read Chap. 1.1 and Appendix C)

Most Important Topics and Concepts

- Concept of phasors & notations
- RMS value
- Phasor diagrams for basic RLC circuits
- Balanced 3-phase system, Y / Δ connections
- Real, reactive, and apparent power in 1-phase and 3-phase systems, power factor

11

Review of AC Circuits

- Consider linear inductive circuit

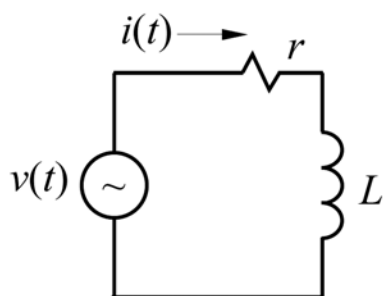

Steady-state Solution

$$i(t) = I_m \cos(\omega t + \varphi_i)$$

$$e(t) = E_m \cos(\omega t + \varphi_e)$$

$$v(t) = V_m \cos(\omega t)$$

KVL

$$\begin{aligned} v(t) &= ri + e = ri + \frac{d\lambda}{dt} \\ &= ri + L \frac{di}{dt} \end{aligned}$$

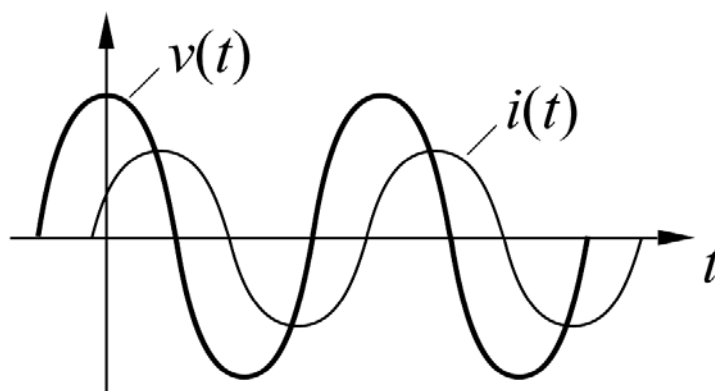

12

Review of AC Circuits

- Consider linear capacitive circuit

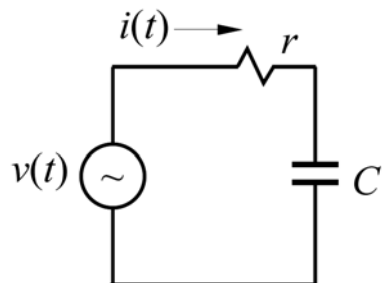

Steady-state Solution

$$v_c(t) = V_{c,m} \cos(\omega t + \phi_v)$$

$$i(t) = I_m \cos(\omega t + \phi_i)$$

$$v(t) = V_m \cos(\omega t)$$

$$\text{KVL } v(t) = ri + v_c$$

$$i = \frac{v - v_c}{r} = C \frac{dv_c}{dt}$$

$$C \frac{dv_c}{dt} + \frac{1}{r} v_c = \frac{1}{r} v(t)$$

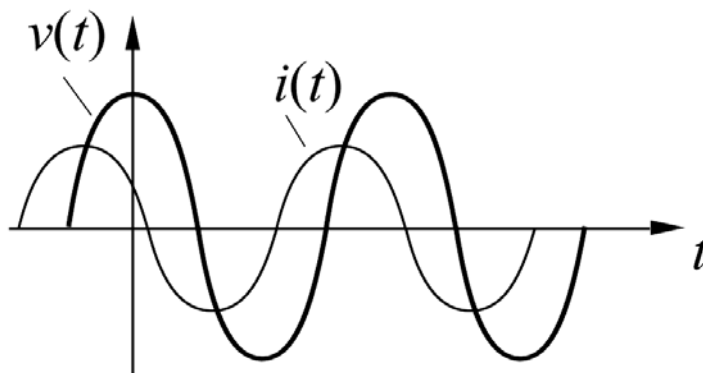

Note: In both cases we need to know only amplitude & phase !

13

Review of Phasors

- Complex Plane

$$v(t) = V_m \cos(\omega t) + j \cdot V_m \sin(\omega t)$$

$$i(t) = I_m \cos(\omega t - \phi) + j \cdot I_m \sin(\omega t - \phi)$$

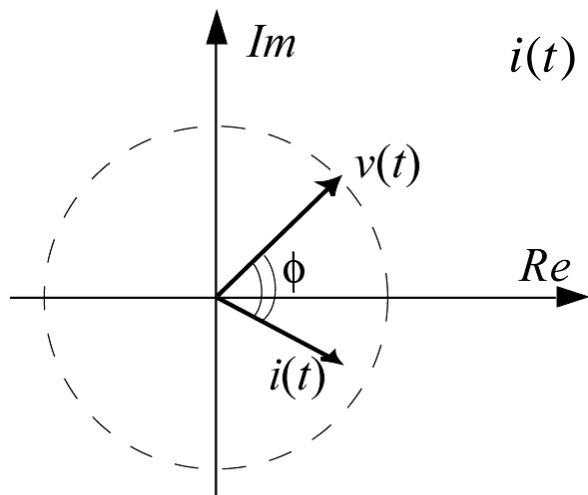

Euler's Identity

$$e^{j\omega t} = \cos(\omega t) + j \sin(\omega t)$$

$$v(t) = V_m e^{j\omega t}$$

$$i(t) = I_m e^{j(\omega t - \phi)}$$

Note:

- All vectors rotate at the same speed ω !
- Only the amplitudes and their phase differences are important

14

Phasor Notations

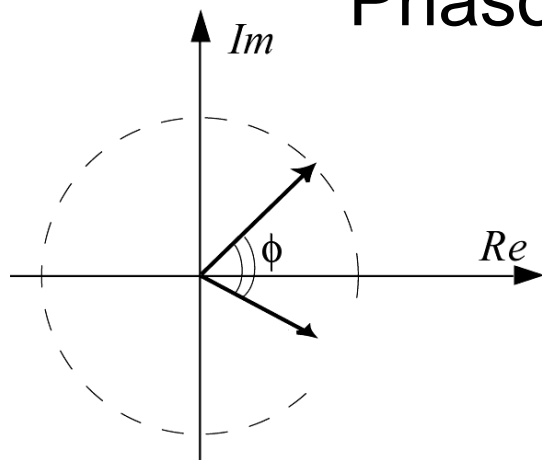



$$i(t) = I_m e^{j(\omega t - \phi)} \equiv I_m \angle -\phi$$

$$v(t) = V_m e^{j\omega t} \equiv V_m \angle 0$$

Time Domain	Phasor Representation
$A \cos(\omega t \pm \theta)$	$A \angle \pm \theta$
$A \sin(\omega t \pm \theta)$	$A \angle \pm \theta - 90^\circ$

15

Review of Phasors

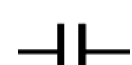
Linear Passive Elements	Complex Impedance
 R	$Z = R$
 L	$Z = j\omega L = (\omega L) \angle 90^\circ$
 C	$Z = \frac{1}{j\omega C} = \left(\frac{1}{\omega C} \right) \angle -90^\circ$

$$Z = \frac{V}{I} = \frac{V_m \angle \theta_v}{I_m \angle \theta_i} = \frac{V_m}{I_m} \angle \theta_v - \theta_i = Z_m \angle \theta_z$$

$$Z = R + jX, \quad Z_m = \sqrt{R^2 + X^2}, \quad \theta_z = \arctan\left(\frac{X}{R}\right)$$

16

Root-Mean-Square (RMS) Value

* Value equivalent to the DC voltage (current) that when applied to a resistor dissipates the same average amount of power as the given AC

$$P(t) = vi = v \frac{v}{r} = \frac{1}{r} v^2$$

$$P_{ave} = \frac{1}{T} \int_0^T P(t) dt = \frac{1}{r} \cdot \frac{1}{T} \int_0^T v^2(t) dt$$

$$V_{(rms)} = \sqrt{\frac{1}{T} \int_0^T v^2(t) dt}$$

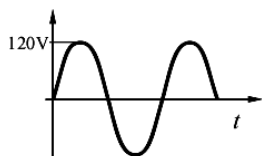
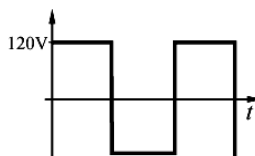
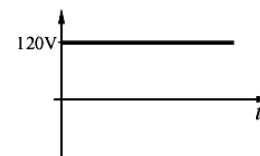
 $V_{rms} =$

 $V_{rms} =$

 $V_{rms} =$

Given sinusoidal voltage (current), RMS values are often used with Phasors

$$v(t) = \sqrt{2} \cdot V_{rms} \cos(\omega t + \phi_v)$$

$$\tilde{V} = V_{rms} \angle \phi_v$$

$$i(t) = \sqrt{2} \cdot I_{rms} \cos(\omega t + \phi_i)$$

$$\tilde{I} = I_{rms} \angle \phi_i$$

17

Qualitative Phasor Diagrams

Consider RLC Circuit

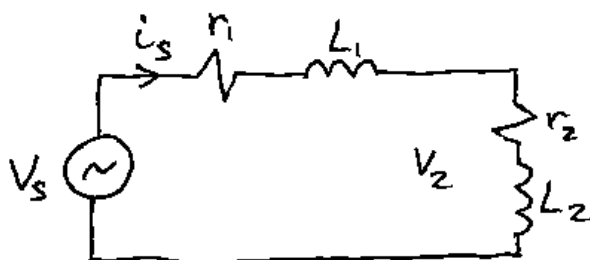

18

Power in AC Circuits

Given inductive load

$$v(t) = \sqrt{2} \cdot V \cos(\omega t) \quad i(t) = \sqrt{2} \cdot I \cos(\omega t + \varphi)$$

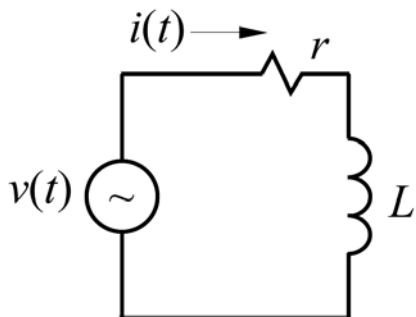

Instantiations power is always this

$$\begin{aligned} p(t) &= vi = 2VI \cos(\omega t) \cos(\omega t + \varphi) \\ &= VI \cos(\varphi) + VI \cos(2\omega t + \varphi) \end{aligned}$$

Average (real) power over one cycle $P = VI \cos(\varphi)$ [W], [kW], [MW]

Apparent power $S = VI = \sqrt{P^2 + Q^2}$ [VA], [kVA], [MVA]

Reactive power $Q = VI \sin(\varphi)$ [VAR], [kVAR], [MVAR]

Power Factor (pf) $\cos(\varphi) = \frac{P}{VI}$

19

Single vs. Three-Phase Systems

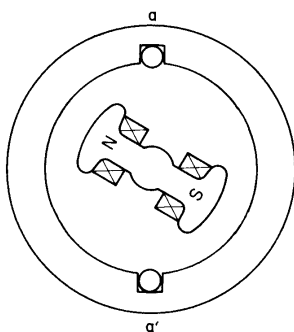

$$v(t) = V_m \cos(\omega t)$$

Easy to produce !

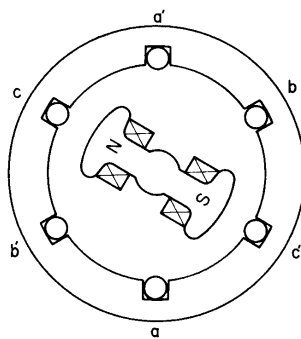

$$v_a(t) = V_m \cos(\omega t)$$

$$v_b(t) = V_m \cos(\omega t - 120^\circ)$$

$$v_c(t) = V_m \cos(\omega t + 120^\circ)$$

Just as easy to produce !

For balanced system
we have $v_a + v_b + v_c = 0$

20

Balanced Three-Phase Systems

Single vs. Three Phases

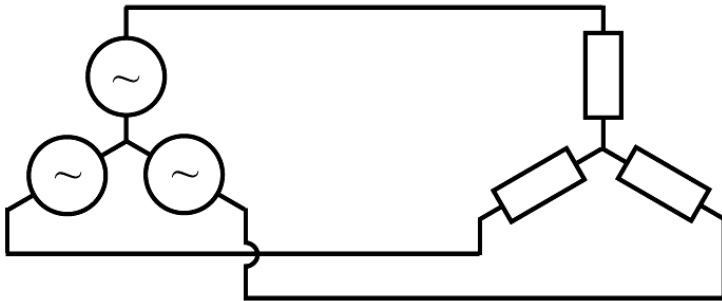

Efficient transmission of power
 – just one more conductor
 = 3 times more power

21

Three-Phase Source

Wye (Y) - Connected

Line Voltages

$$V_{ab} = V_a - V_b$$

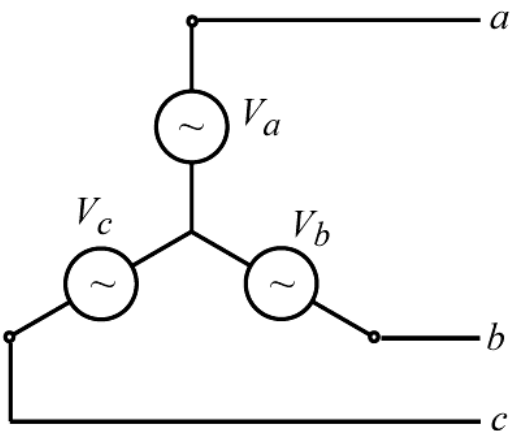

22

Three-Phase Source

Delta (Δ) - Connected

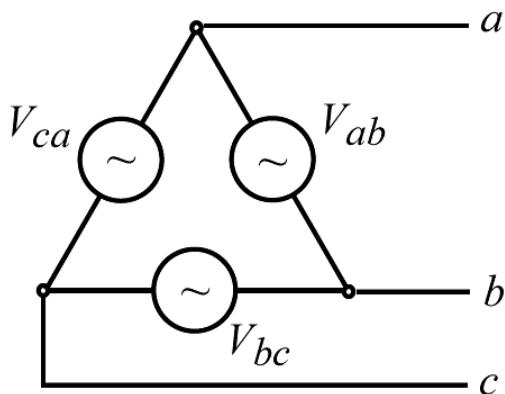

Line Currents

$$I_a = I_{ab} - I_{ca}$$

23

Power in Three-Phase Systems

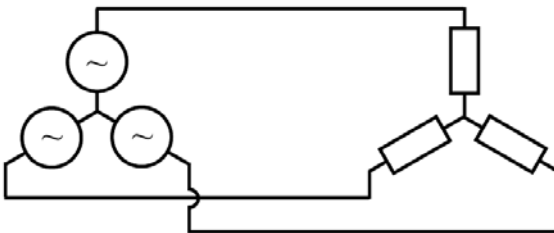

Instantaneous Power

$$\begin{aligned} P_{3\phi}(t) &= P_a + P_b + P_c \\ &= i_a v_a + i_b v_b + i_c v_c \end{aligned}$$

$$v_a(t) = \sqrt{2}V_{ph} \cos(\omega t)$$

$$v_b(t) = \sqrt{2}V_{ph} \cos(\omega t - 120^\circ)$$

$$v_c(t) = \sqrt{2}V_{ph} \cos(\omega t + 120^\circ)$$

$$i_a(t) = \sqrt{2}I_{ph} \cos(\omega t - \varphi)$$

$$i_b(t) = \sqrt{2}I_{ph} \cos(\omega t - 120^\circ - \varphi)$$

$$i_c(t) = \sqrt{2}I_{ph} \cos(\omega t + 120^\circ - \varphi)$$

24

Power in Balanced Three-Phase Systems

In terms of phase quantities (Y - connection)

$$P_{3\phi} = 3P_{ph} = 3V_{ph}I_{ph} \cos(\varphi_{ph})$$

$$Q_{3\phi} = 3Q_{ph} = 3V_{ph}I_{ph} \sin(\varphi_{ph})$$

$$S_{3\phi} = 3S_{ph} = 3V_{ph}I_{ph}$$

In terms of line-to-line quantities

Y - connection

$$I_{ph} = I_L, V_{ph} = V_L / \sqrt{3}$$

Δ - connection

$$I_{ph} = I_L / \sqrt{3}, V_{ph} = V_L$$

$$P_{3\phi} = \sqrt{3}V_L I_L \cos(\varphi_{ph})$$

$$Q_{3\phi} = \sqrt{3}V_L I_L \sin(\varphi_{ph})$$

$$S_{3\phi} = \sqrt{3}V_L I_L$$

25

Module 1, Part 2

Introduction & Magnetic Circuits (Read Chapter 1.3 – 1.4)

Most Important Topics

- Fundamentals of Electromagnetics, Maxwell's Equations
- Sign & direction conventions
- Basic magnetic circuits, concepts, analogies, calculations
- Flux, flux linkage, inductance
- Magnetic materials, saturation, hysteresis loop
- Coil under ac excitation, type of core losses

26

Review of Basic Quantities and Units

E – electric field intensity $\left[\frac{V}{m}\right]$

B – magnetic flux density $\left[Tesla = \frac{Weber}{meter^2}\right]$ $\left[T = \frac{Wb}{m^2}\right]$

H – magnetic field intensity $\left[\frac{A}{m}\right]$

Φ – magnetic flux $[Wb = T \cdot m^2]$

B-H Relation

- Current produces the H field (see Ampere's law)
- H is related to B

$$B = \mu H = \mu_0 \mu_r H$$

μ – permeability (characteristic of the medium) $\left[\frac{T \cdot m}{A} = \frac{Henry}{meter} = \frac{H}{m}\right]$

μ_0 – permeability of vacuum $= 4 \cdot \pi \cdot 10^{-7} [H/m]$

μ_r – relative permeability of material

magnetic materials $\mu_r = 100 \dots 100,000$

27

Fundamentals

Summarized in Maxwell's Equations (1870s)

1) Gauss's Law for Electric Field

$$\oint_s \mathbf{E} \cdot d\mathbf{a} = \frac{q}{\epsilon_0} = \Phi_e = \int E \cos \theta da$$

Electric flux out of any closed surface is proportional to the total charge enclosed

28

Fundamentals

Summarized in Maxwell's Equations (1870s)

2) Gauss's Law for Magnetic Field

$$\oint_s \mathbf{B} \cdot d\mathbf{a} = \Phi_m = 0$$

Magnetic flux out of any closed surface is zero

There are no magnetic charges

Fundamentals

Summarized in Maxwell's Equations (1870s)

3) Faraday's Law

$$\oint_C \mathbf{E} \cdot d\mathbf{l} = -\frac{d}{dt} \int_s \mathbf{B} \cdot d\mathbf{a} = -\frac{d\Phi}{dt} = emf$$

ElectroMotive Force (emf)

The line integral of the electric field around a closed loop/contour C is equal to the negative of the rate of change of the magnetic flux through that loop/contour

Fundamentals

Summarized in Maxwell's Equations (1870s)

4) Ampere's Law (for static electric field)

$$\oint_C \mathbf{B} \cdot d\mathbf{l} = \mu_0 \int_S \mathbf{J} \cdot d\mathbf{a} = \mu_0 I_{net}$$

The line integral of the magnetic field \mathbf{B} around a closed loop C is proportional to the net electric current flowing through that loop/contour C

31

Conventions

Right hand rule

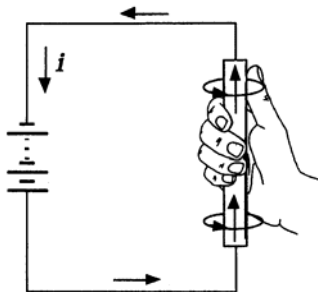

Right-screw rule

Dot and cross notations

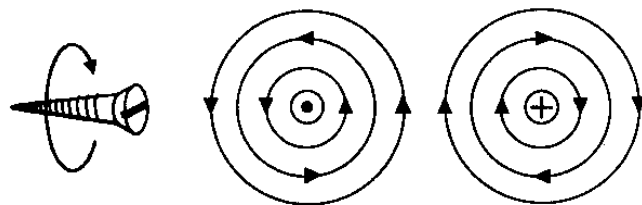

Magnetic field produced by coil (solenoid)

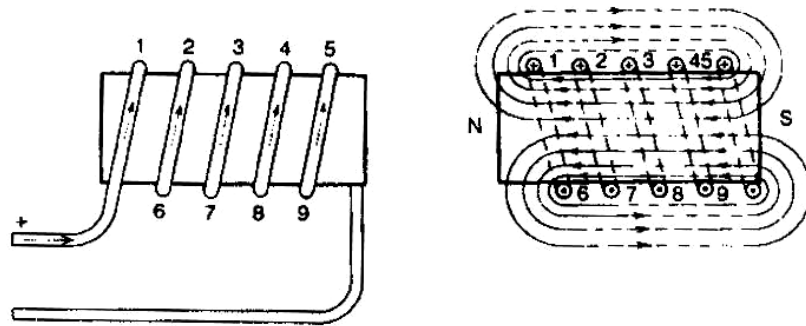

Flux Lines:

- form a closed loop/path
- Lines do not cut across or merge
- Go from North to South magnetic poles

32

Magnetic Field of an Infinite Conductor

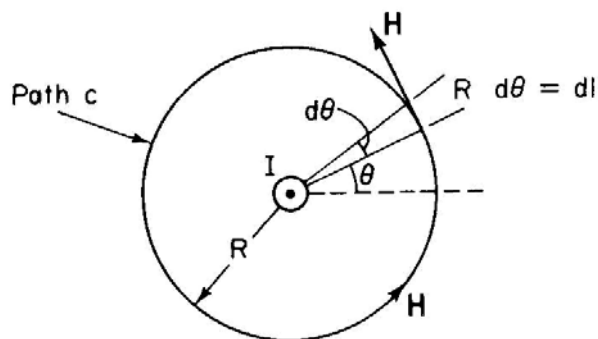

Apply Ampere's Law

$$\oint_C \mathbf{H} \cdot d\mathbf{l} = I_{\text{enclosed}}$$

Incremental length $d\mathbf{l} = R d\theta$

$$H \cdot 2\pi R = I$$

$$H = \frac{I}{2\pi R}$$

$$B = \mu H = \frac{\mu I}{2\pi R}$$

\mathbf{H} and $d\mathbf{l}$ have the same direction

33

Magnetic Field of an Infinite Conductor

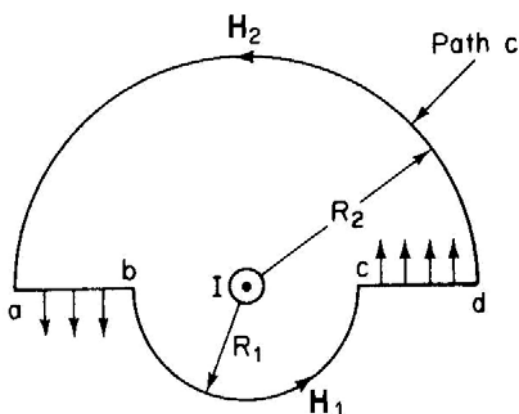

Apply Ampere's Law

$$\oint_C \mathbf{H} \cdot d\mathbf{l} = I_{\text{enclosed}}$$

$$\oint_C \mathbf{H} \cdot d\mathbf{l} = \int_a^b H \cdot dl + \int_b^c H_1 \cdot dl + \int_c^d H \cdot dl + \int_d^a H_2 \cdot dl$$

$$\int_b^c H_1 \cdot dl = \int_{-\pi}^0 \frac{I}{2\pi R_1} R_1 d\theta = \frac{I}{2}$$

$$\int_d^a H_2 \cdot dl = \int_0^{\pi} \frac{I}{2\pi R_2} R_2 d\theta = \frac{I}{2}$$

34

Some Definitions

Magnetic Flux $\Phi = \int_S \mathbf{B} \cdot d\mathbf{a} = B_c A_c$

Flux is always continuous

Recall Faraday's Law - **Electromotive Force (emf)**

$$\oint_C \mathbf{E} \cdot d\mathbf{l} = -\frac{d}{dt} \int_S \mathbf{B} \cdot d\mathbf{a} = -\frac{d\Phi}{dt}$$

- voltage induced in one turn due to the changing magnetic flux

For coil with N turns $e = N \cdot \frac{d\Phi}{dt}$

Flux Linkage $\lambda = N \cdot \Phi$ [Wb·t]

flux scaled by the number of turns

Total induced emf $e = \frac{d\lambda}{dt}$ [V]

35

Some Definitions

Inductance

Need a function that relates Flux Linkage to the Current

Consider $\lambda = f(i) = L(\cdot) \cdot i$ $L = \frac{\lambda}{i}$ $\left[\frac{\text{Wb} \cdot \text{t}}{\text{A}} = \text{H} \right]$

Recall

$$L = \frac{\lambda}{i} = \frac{N \cdot \Phi}{i}$$

36

Magnetic Circuits

- Consider basic magnetic circuit

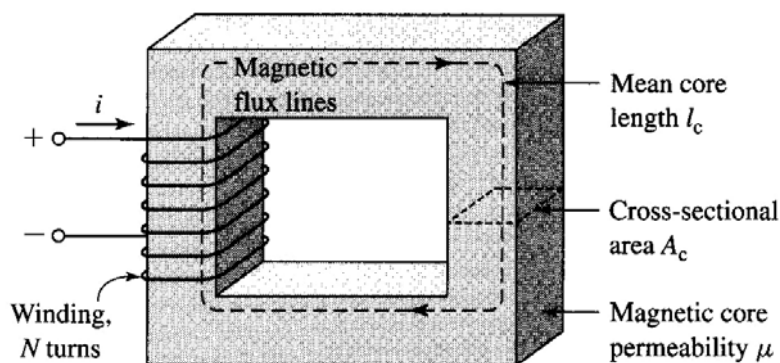

Assume $\mu \gg \mu_0$

\Rightarrow All magnetic field is concentrated inside the core

Recall Ampere's Law

$$\oint_{l_c} \mathbf{H}_c \cdot d\mathbf{l} = I_{net}$$

Magnetomotive force (mmf) $F = Ni$

Source of magnetic field is ampere-turn product

Assume uniform core $F = Ni = I_{net} = \oint_{l_c} \mathbf{H}_c \cdot d\mathbf{l} = H_c l_c$ [Ampere·turn]

37

Magnetic Circuits

- Consider basic magnetic circuit

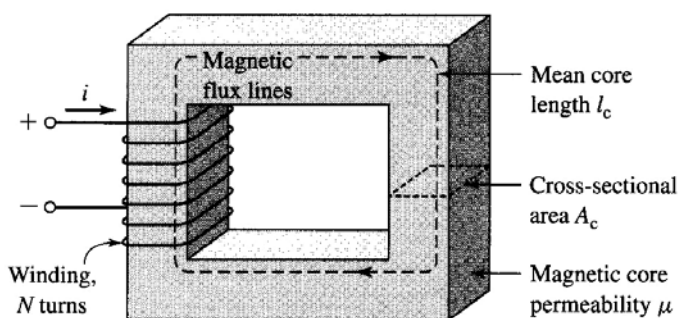

Assume all magnetic field is confined inside the core

Define Magnetic Flux

$$\Phi = \int_S \mathbf{B} \cdot d\mathbf{a} = B_c A_c$$

Flux is always continuous [Wb]

Consider mmf $F = Ni = H_c l_c = \frac{B_c l_c}{\mu} = \Phi \frac{l_c}{\mu A_c} = \Phi \mathcal{R}_c$

Define Reluctance (of the given magnetic path) $\mathcal{R}_c = \frac{l_c}{\mu A_c}$ $\left[\frac{A}{Wb} \right]$

Recall Inductance

$$L = \frac{\lambda}{i} = \frac{N \cdot \Phi}{i} = \frac{N \cdot N \cdot i}{i \cdot \mathcal{R}_c} = \frac{N^2}{\mathcal{R}_c}$$

38

Magnetic Circuits

- Magnetic circuit with air gap

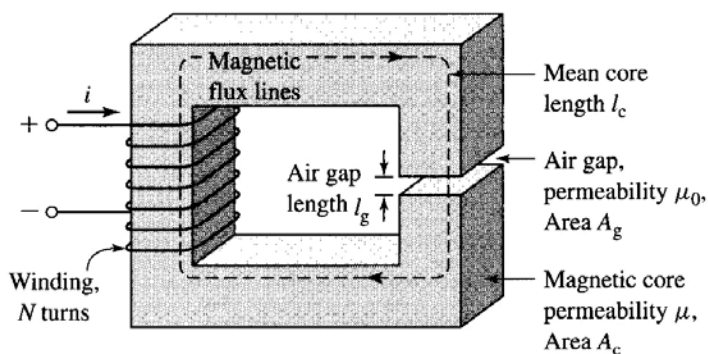

Consider mmf

$$\begin{aligned} F = Ni &= \oint_C \mathbf{H} \cdot d\mathbf{l} \\ &= H_c l_c + H_g l_g \\ &= \frac{B_c l_c}{\mu} + \frac{B_g l_g}{\mu_0} \end{aligned}$$

Assuming all magnetic flux is confined inside the core

$$B_c = \frac{\Phi}{A_c} \quad \text{and} \quad B_g = \frac{\Phi}{A_g}$$

$$F = \Phi \left(\frac{l_c}{\mu A_c} + \frac{l_g}{\mu_0 A_g} \right) = \Phi (\mathcal{R}_c + \mathcal{R}_g) = \Phi \sum \mathcal{R}_i = \Phi \mathcal{R}_{total}$$

39

Magnetic and Electric Circuits Analogy

Electric Circuit

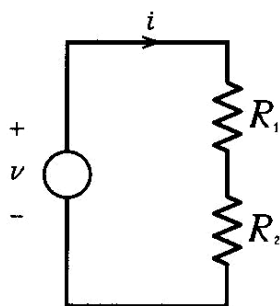

$$i = \frac{v}{R_1 + R_2}$$

Magnetic Circuit

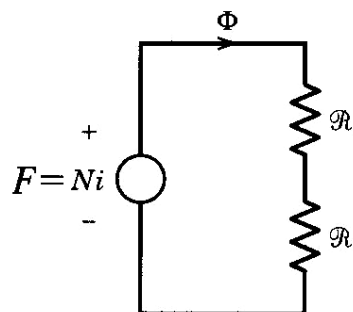

$$\Phi = \frac{F}{\mathcal{R}_1 + \mathcal{R}_2}$$

40

Magnetic and Electric Circuits Analogy

Electric Circuit

- Voltage (emf), $V, [Volt]$
- Current, $I, [Amps]$
- Resistance, $R = \frac{l}{\sigma A}, [\Omega]$
- Conductance, $G = \frac{1}{R}, [Siemens]$
- Conductivity, $\sigma, \left[\frac{Siemens}{m} \right]$

For loop $v = \sum R_n i_n$

For node $\sum_N i_n = 0$

Magnetic Circuit

- mmf, $F, [A \cdot t]$
- Flux $\Phi, [Wb]$
- Reluctance, $\mathfrak{R} = \frac{l}{\mu A}, \left[\frac{A}{Wb} \right]$
- Permeance, $\rho = \frac{1}{\mathfrak{R}}, \left[\frac{Wb}{A} \right]$
- Permeability, $\mu, \left[\frac{H}{m} \right]$

For loop $F = \sum H_n l_n$

For node $\sum_N \Phi_n = 0$

41

Inductance: Example 1

Consider the following electromagnetic system (device)

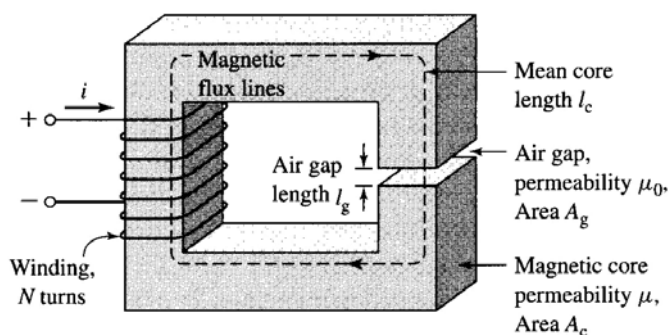

Equivalent Magnetic Circuit

Equivalent Electric Circuit

42

Inductance: Example 1

Consider the following electromagnetic system

$$i = 1 \text{ A}, N = 400$$

$$l_c = 50 \text{ cm}, l_g = 1 \text{ mm}$$

$$A_c = A_g = 15 \text{ cm}^2$$

$$\mu_r = 3000$$

Find inductance $L = \frac{N^2}{\mathcal{R}_c + \mathcal{R}_g}$

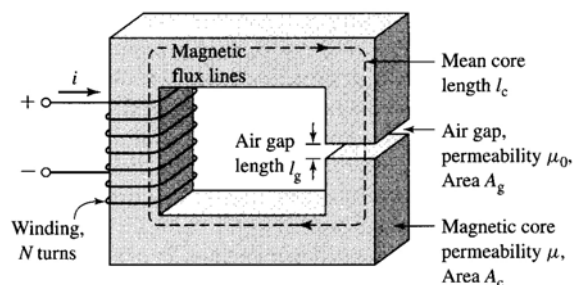

$$\mathcal{R}_c = \frac{l_c}{\mu_r \mu_0 A_c} = \frac{50 \times 10^{-2}}{3000 \cdot 4\pi \cdot 10^{-7} \cdot 15 \times 10^{-4}} \approx 88.42 \text{ e}+3 \text{ A}\cdot\text{t}/\text{Wb}$$

$$\mathcal{R}_g = \frac{l_g}{\mu_0 A_g} = \frac{1 \times 10^{-3}}{4\pi \cdot 10^{-7} \cdot 15 \times 10^{-4}} \approx 530.515 \text{ e}+3 \text{ A}\cdot\text{t}/\text{Wb}$$

$$L = \frac{400^2}{(88.42 + 530.515) \cdot \text{e}+3} = 258.52 \text{ e}-3 \text{ H}$$

$$= 258.52 \text{ mH}$$

43

Magnetic Circuits: Example 2

Consider the following electromagnetic system

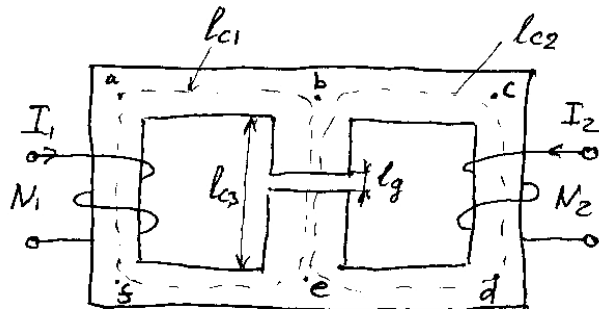

Path $l_{c1} = \text{base}$
 Path $l_{c2} = \text{bcde}$
 Path $l_{c3} = \text{be} - l_g$
 l_{c3} includes only core

Equivalent Magnetic Circuit

44

Magnetic Circuits: Example 2

Consider the following electromagnetic system

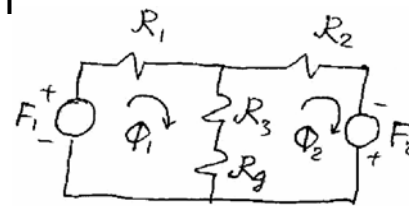

Loop Equations

$$\Phi_1(R_1 + R_3 + R_g) - \Phi_2(R_3 + R_g) = F_1$$

$$-\Phi_1(R_3 + R_g) + \Phi_2(R_2 + R_3 + R_g) = F_2$$

Solve for fluxes

$$\begin{bmatrix} R_1 + R_3 + R_g & -(R_3 + R_g) \\ -(R_3 + R_g) & R_2 + R_3 + R_g \end{bmatrix} \begin{bmatrix} \Phi_1 \\ \Phi_2 \end{bmatrix} = \begin{bmatrix} F_1 \\ F_2 \end{bmatrix} = \begin{bmatrix} N_1 I_1 \\ N_2 I_2 \end{bmatrix}$$

$$A \cdot X = b \Rightarrow X = A^{-1} \cdot b$$

45

Magnetic Materials

Magnetic moment
of an atom

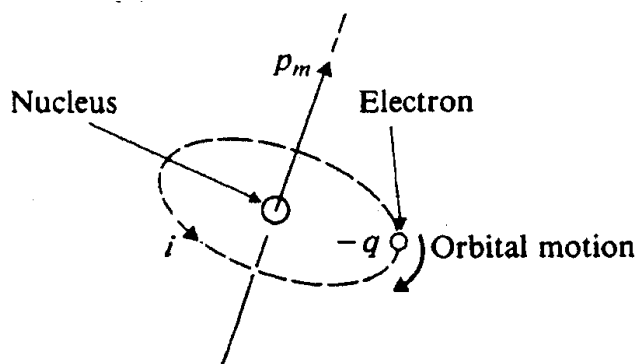

Magnetic Domain Structure

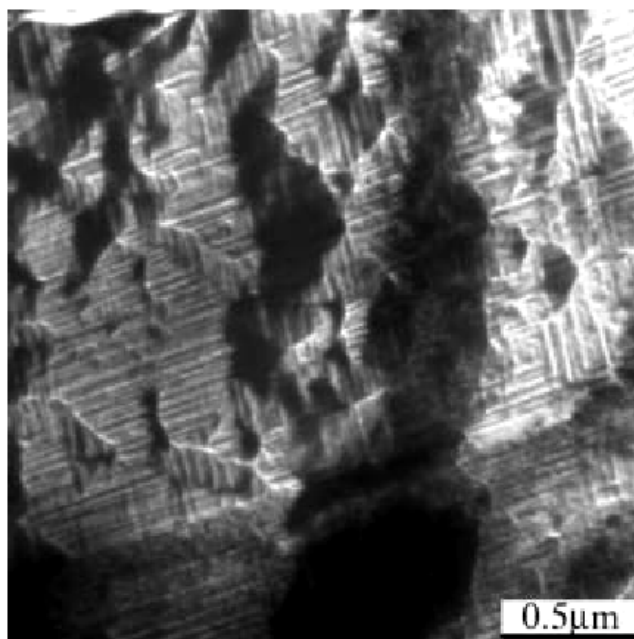

46

Magnetic Material Domain Model

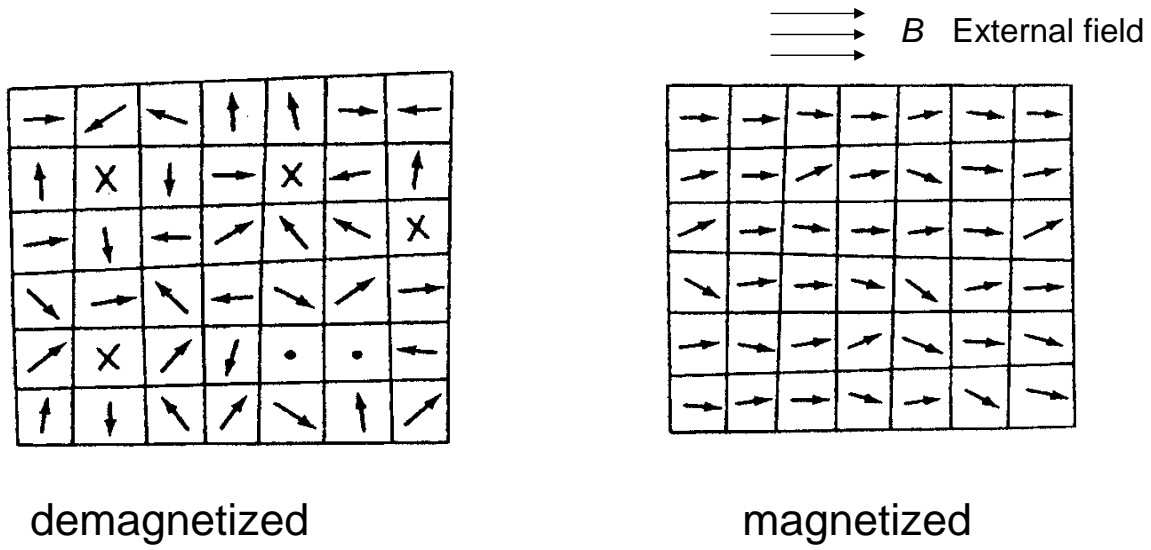

Magnetic Saturation

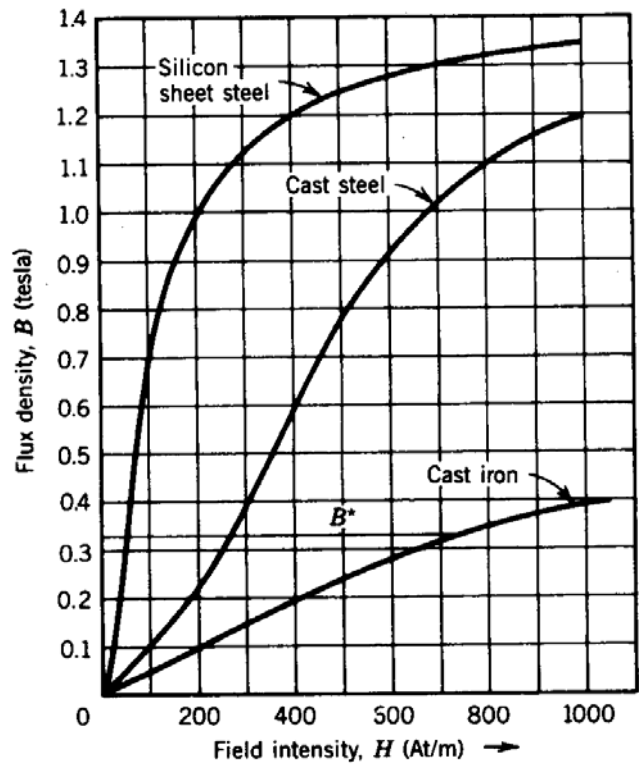
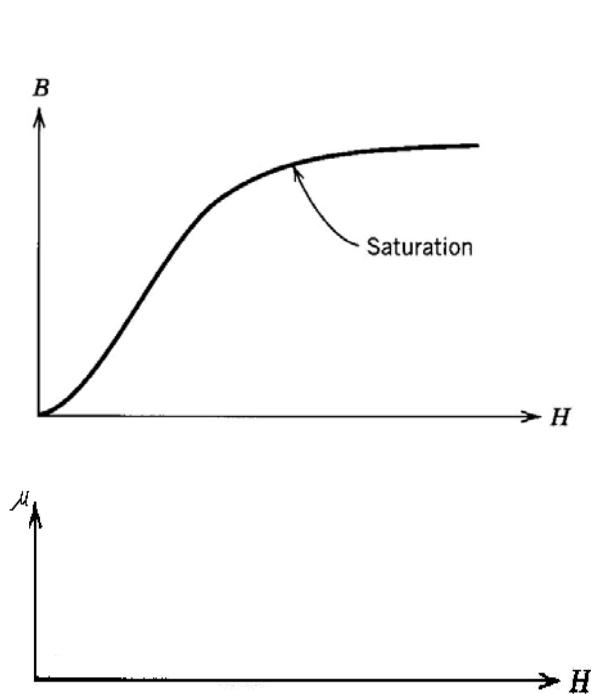

Hysteresis Loop

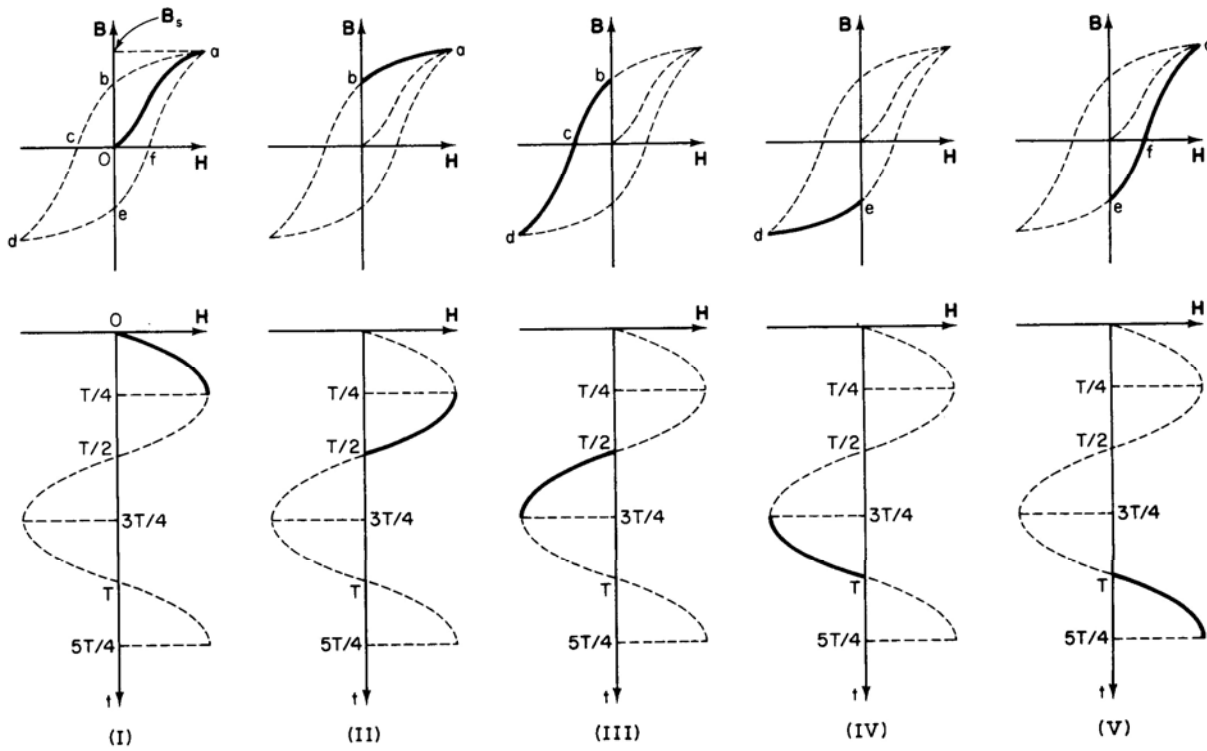

Hysteresis Loop

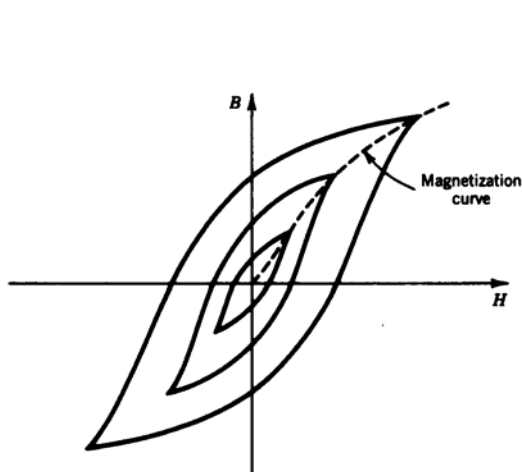

Hysteresis loops for different excitation levels

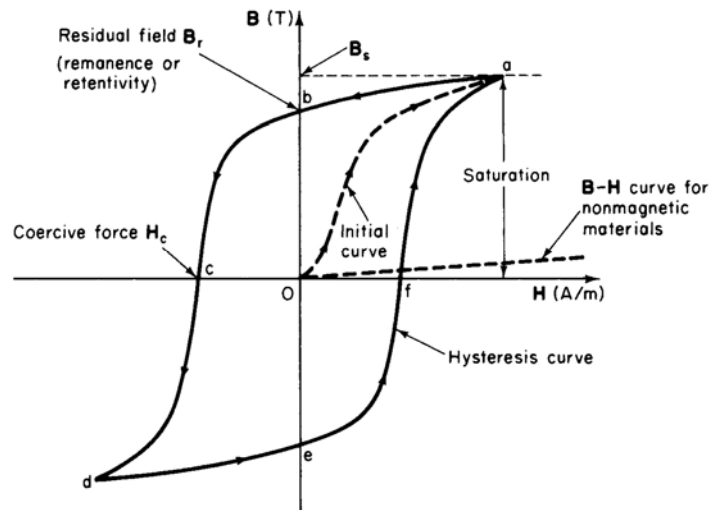

B_r – residual magnetism
 H_c – coercivity force, external field required to demagnetize the material

Magnetic Materials

Classes of Magnetic Materials

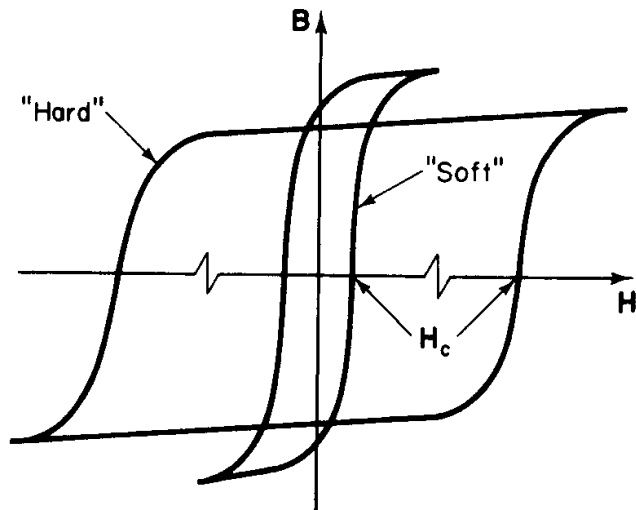

Soft mag. materials

$$H_c \sim 0.1 \dots 100 \text{ [A/m]}$$

Hard mag. materials

$$H_c > 100 \text{ [A/m]}$$

Permanent magnets (PM)

$$H_c \sim 10^4 \dots 10^6 \text{ [A/m]}$$

Types of PMs

- Neodymium Iron Boron (NdFeB or NIB)
- Samarium Cobalt (SmCo)
- Aluminum Nickel Cobalt (Alnico)
- Ceramic or Ferrite, very popular
Iron-oxide, barium, etc. compressed powder

Magnetic Materials

Second quadrant hysteresis curve for M-5 steel and Alnico 5

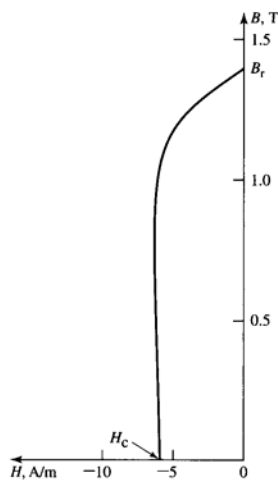

M-5 Steel

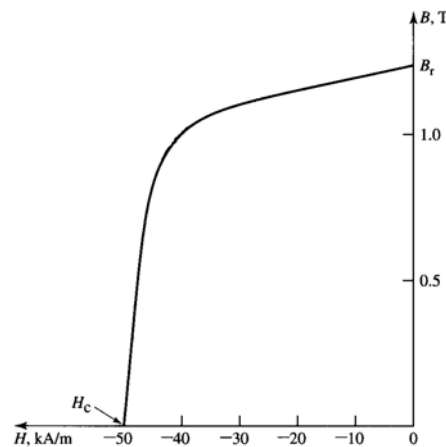

Alnico 5

Magnetic Materials

Second quadrant hysteresis curve for some common PM materials

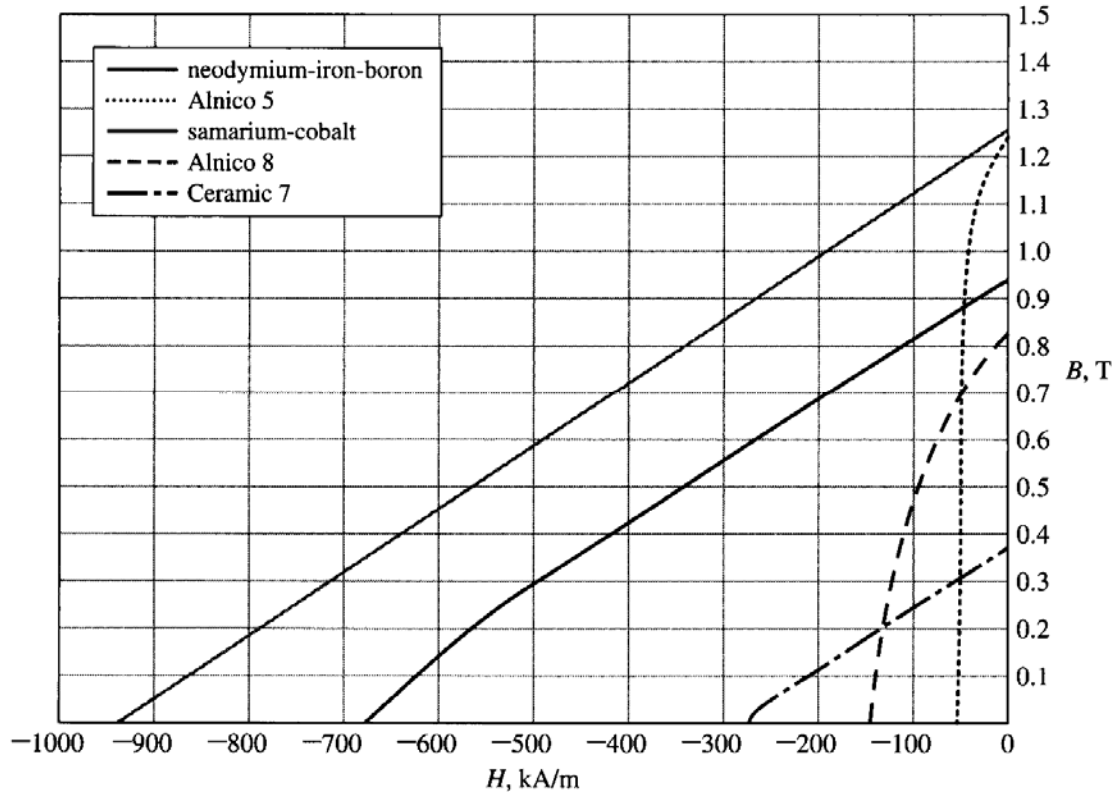

53

Core Losses

Hysteresis Losses

Consider
AC
excitation

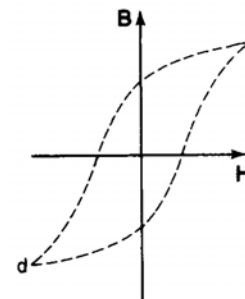
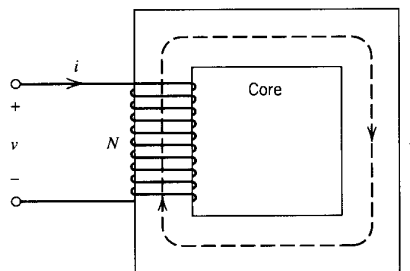

$$\Delta W_{h,cycle} = \oint i d\lambda = \oint \left(\frac{H_c l_c}{N} \right) (N A_c dB_c) = l_c A_c \oint H_c dB_c$$

Power loss can be approximated as

$$P_h = K_h \cdot f \cdot (B_{c,max})^n \quad n \sim 1.5 \dots 2.5$$

Where the constants K_h and n determined experimentally

54

Core Losses

Faraday's law

$$\oint_C \vec{E} \cdot d\vec{l} = -\frac{d}{dt} \int_S \vec{B} \cdot d\vec{a}$$

Eddy Current Losses

Consider
AC
excitation

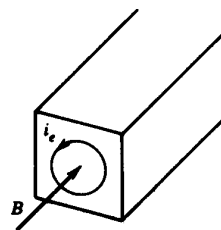
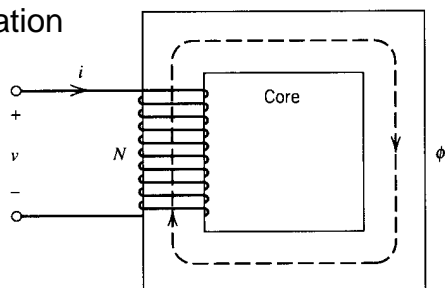

Solid-iron core

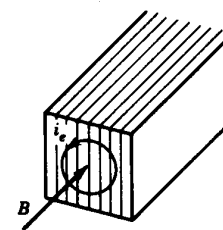

Laminated core

Power loss can be approximated as

$$P_e = K_e \cdot f^2 \cdot (B_{c,\max})^2$$

Where the constant K_e depends on lamination thickness and is determined experimentally

Equivalent circuit including core losses ?

55

Module 1, Part 3

Stationary Magnetically Coupled Systems (Chap. 1.5)

Most Important Topics and Concepts

- Types and construction of typical transformers
- Terminology, winding polarity
- Ideal transformer, turns ration, referring quantities
- Non-ideal transformer, equivalent magnetic and electric circuits
- 3-phase transformers, winding connections

56

Transformer

- Stationary electromagnetic device
 - Is not an energy conversion device
 - It allows to scale voltage/current levels
 - Inverting polarity of signals
 - Galvanic decoupling
 - A transformer may have multiple windings for different voltage levels

57

Transformer Applications

EECE 376, S-15, M-1



Power systems



Small power supplies



Toroids



Variacs



instrumentation

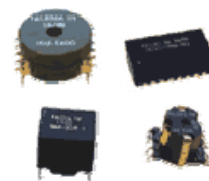

communication

58

Basic Transformer Terminology

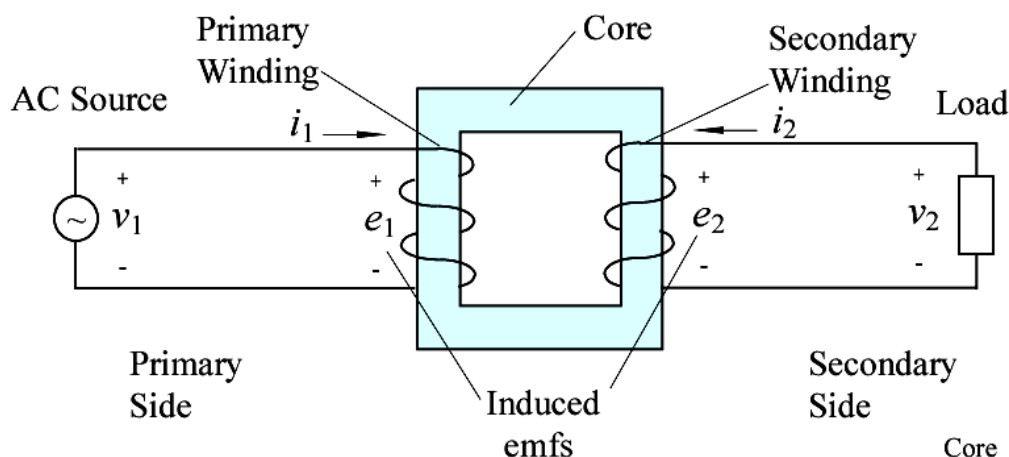

- **Step-down**
 - **Primary** (Source) – high voltage and number of turns (low current)
 - **Secondary** (Load) – low voltage and number of turns (high current)
- **Step-up**
 - **Primary** (Source) – low voltage and number of turns (high current)
 - **Secondary** (Load) – high voltage and number of turns (low current)

59

Transformer Polarity

- Dot convention (most common) – same polarity terminals
- *H-X* convention (*H* – high voltage, *X* – low voltage)

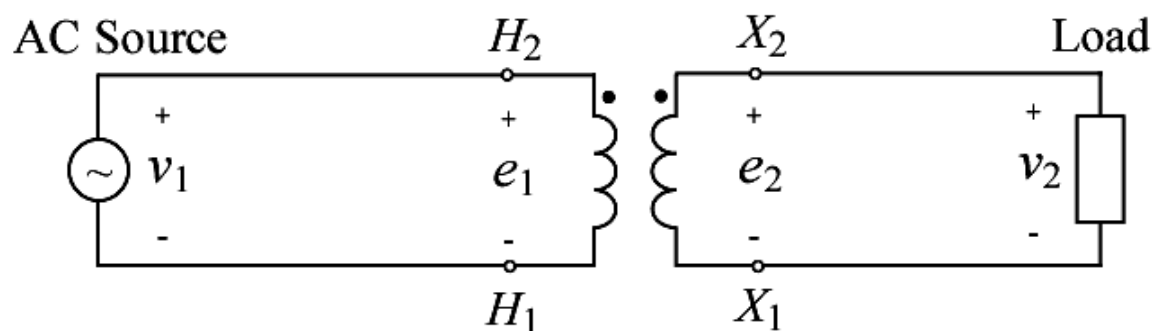

60

Ideal Transformer

Assumptions

- Winding resistance is negligible $r_1, r_2 \rightarrow 0$
- Infinite core permeability $\mu_{core} \rightarrow \infty$
- All flux is confined inside the core
- No core losses

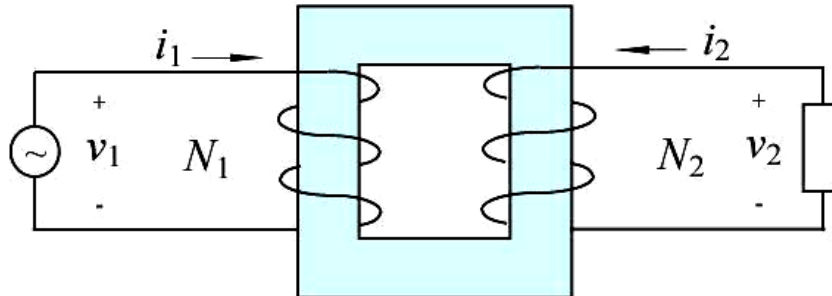

61

Properties of Ideal Transformer

Primary Side

$$v_1 = \sqrt{2}V_{1,rms} \cos(\omega t)$$

$$v_1 = e_1 = \frac{d\lambda_1}{dt} = N_1 \frac{d\Phi}{dt}$$

$$\Phi = \frac{\sqrt{2}V_{1,rms}}{N_1\omega} \sin(\omega t) = \Phi_{peak} \sin(\omega t)$$

$$\Phi_{peak} = \frac{\sqrt{2}V_{1,rms}}{N_1\omega} = \frac{V_{1,rms}}{\sqrt{2}N_1\pi \cdot f}$$

$$B_{peak} = \frac{\Phi_{peak}}{A_c} \approx 1 \dots 2 \text{ T} \quad \text{Maximum Flux Density}$$

Secondary Side

$$v_2 = e_2 = \frac{d\lambda_2}{dt} = N_2 \frac{d\Phi}{dt}$$

$$\frac{d\Phi}{dt} = \frac{v_1}{N_1} = \frac{v_2}{N_2}$$

$$\frac{v_1}{v_2} = \frac{N_1}{N_2} = a \quad \text{Turns ratio}$$

62

Properties of Ideal Transformer

MMF $F = N_1 i_1 + N_2 i_2 = \Phi \mathcal{R}_{total} = 0$

$$\Rightarrow N_1 i_1 = -N_2 i_2 \Rightarrow \frac{i_1}{i_2} = \frac{-N_2}{N_1} = \frac{-1}{a}$$

Power $P(t) = i_1 v_1 = -i_2 v_2$ $P_1 = -P_2$ $P_{in} = P_{out}$ No losses

Equivalent Electric Circuit

Equivalent Magnetic Circuit

63

Practical (Non-Ideal) Transformer

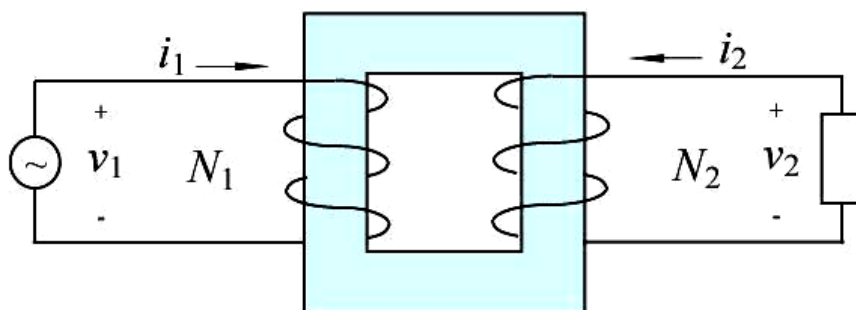

Equivalent Magnetic Circuit ?

Φ_m - mutual or magnetizing flux
(goes inside the core and links
both windings)

Φ_{l1}, Φ_{l2} - flux leakage
(goes in the air and links
only one winding)

64

Transformer

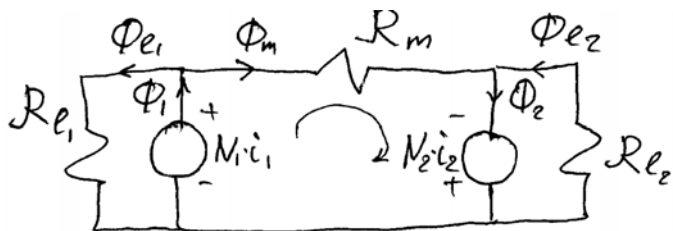

Consider Fluxes

$$\Phi_1 = \Phi_{l1} + \Phi_m = \frac{N_1 i_1}{\mathcal{R}_{l1}} + \frac{N_1 i_1 + N_2 i_2}{\mathcal{R}_m}$$

$$\Phi_2 = \Phi_{l2} + \Phi_m = \frac{N_2 i_2}{\mathcal{R}_{l2}} + \frac{N_1 i_1 + N_2 i_2}{\mathcal{R}_m}$$

Voltage Equations

$$v_1 = r_1 i_1 + \frac{d\lambda_1}{dt}$$

$$v_2 = r_2 i_2 + \frac{d\lambda_2}{dt}$$

65

Transformer

Consider Flux Linkages

Recall inductance $L = \frac{N^2}{\mathcal{R}}$

$$\lambda_1 = N_1 \Phi_1 = \frac{N_1^2}{\mathcal{R}_{l1}} i_1 + \frac{N_1^2}{\mathcal{R}_m} i_1 + \frac{N_1 N_2}{\mathcal{R}_m} i_2 = L_{l1} i_1 + L_{m1} i_1 + L_{12} i_2$$

$$\lambda_2 = N_2 \Phi_2 = \frac{N_2^2}{\mathcal{R}_{l2}} i_2 + \frac{N_2^2}{\mathcal{R}_m} i_2 + \frac{N_2 N_1}{\mathcal{R}_m} i_1 = L_{l2} i_2 + L_{m2} i_2 + L_{21} i_1$$

Define self-inductances (always positive)

$$L_{11} = L_{l1} + L_{m1}$$

$$L_{22} = L_{l2} + L_{m2}$$

Define mutual inductances

$$L_{12} = \frac{N_1 N_2}{\mathcal{R}_m} \quad L_{21} = \frac{N_2 N_1}{\mathcal{R}_m}$$

Flux Linkages

$$\lambda_1 = L_{11} i_1 + L_{12} i_2$$

$$\lambda_2 = L_{21} i_1 + L_{22} i_2$$

$$L_{12} = \frac{N_2}{N_1} L_{m1} = \frac{N_1}{N_2} L_{m2}$$

(could be positive or negative)

66

Referring Parameters

Re-write Flux Linkages

$$\lambda_1 = L_{l1}i_1 + L_{m1}\left(i_1 + \frac{N_2}{N_1}i_2\right)$$

$$\lambda_2 = L_{l2}i_2 + L_{m2}\left(\frac{N_1}{N_2}i_1 + i_2\right)$$

Substitute (referred) variables

$$i'_2 = \frac{N_2}{N_1}i_2$$

$$p(t) = v_2i_2 = v'_2i'_2 \quad \text{Power the same}$$

$$v'_2 = \frac{N_1}{N_2}v_2 \quad \text{and} \quad \lambda'_2 = \frac{N_1}{N_2}\lambda_2$$

Re-write Flux Linkages

$$\lambda_1 = L_{l1}i_1 + L_{m1}(i_1 + i'_2)$$

$$\lambda_1 = L_{l1}i_1 + L_{m1}i'_2$$

$$\lambda'_2 = L'_{l2}i'_2 + L_{m1}(i_1 + i'_2)$$

$$\lambda'_2 = L_{m1}i_1 + L'_{22}i'_2$$

where

$$L'_{l2} = \left(\frac{N_1}{N_2}\right)^2 L_{l2}$$

where

$$L'_{22} = \left(\frac{N_1}{N_2}\right)^2 L_{22}$$

67

T – Equivalent Circuit

Voltage Equation

$$\begin{bmatrix} v_1 \\ v'_2 \end{bmatrix} = \begin{bmatrix} r_1 & 0 \\ 0 & r'_2 \end{bmatrix} \begin{bmatrix} i_1 \\ i'_2 \end{bmatrix} + \frac{d}{dt} \begin{bmatrix} \lambda_1 \\ \lambda'_2 \end{bmatrix}$$

$$\text{where } r'_2 = \left(\frac{N_1}{N_2}\right)^2 r_2$$

Define Reactances

$$X_{l1} = L_{l1}\omega_e$$

$$X'_{l2} = L'_{l2}\omega_e$$

$$X_{m1} = L_{m1}\omega_e$$

Flux Linkages

$$\lambda_1 = L_{l1}i_1 + L_{m1}(i_1 + i'_2)$$

$$\lambda'_2 = L'_{l2}i'_2 + L_{m1}(i_1 + i'_2)$$

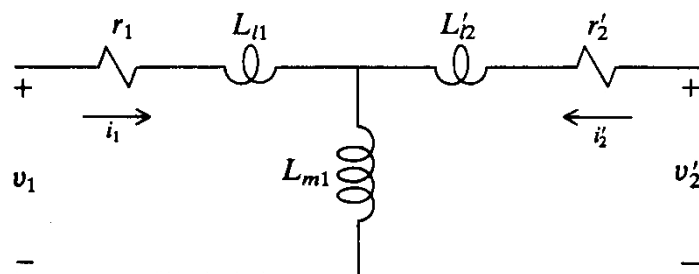

68

Transformer Example

Consider a 50kVA, 2400/240V transformer with leakage impedances $Z_1 = 0.72 + j0.92$ and $Z_2 = 0.007 + j0.009$, and the magnetizing shunt impedance $Z_{m2} = j43$.

- a) Draw eq. circuit referred to high voltage side, label impedances
- b) Draw eq. circuit referred to low voltage side, label impedances

Turns-ratio $a = \frac{2400}{240} = 10$

a) Refer to HV side

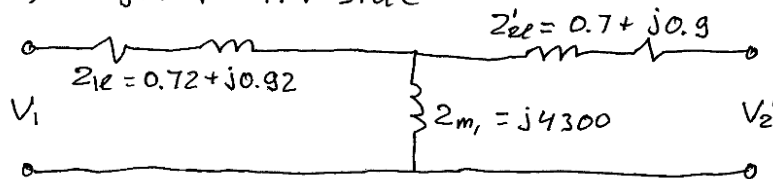

b) Refer to LV side

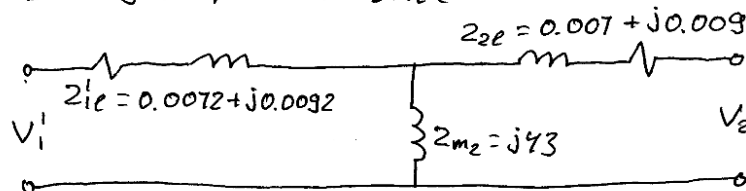

Tap-Changing Multi-winding Transformers

Additional voltage control / regulation

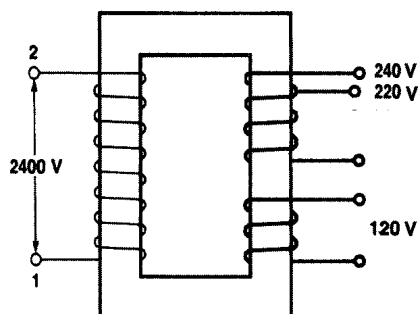
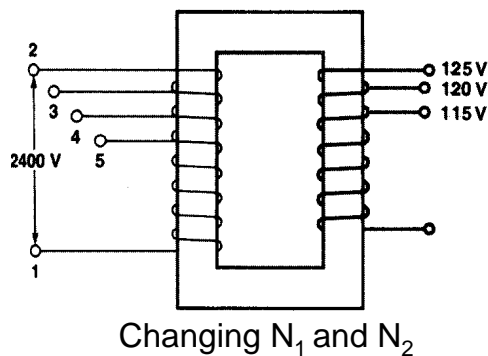
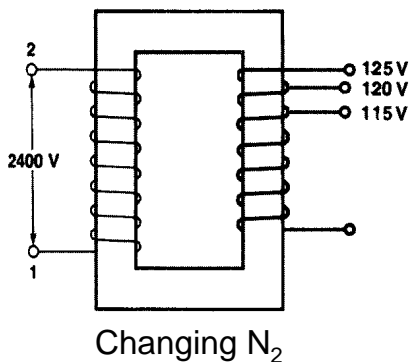

High voltage loads

Regular voltage loads

Two loads are galvanically decoupled !

Autotransformers

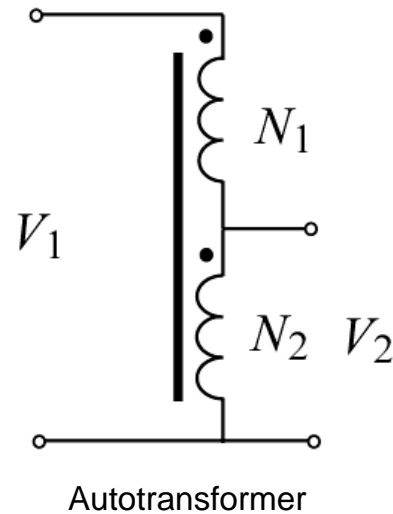
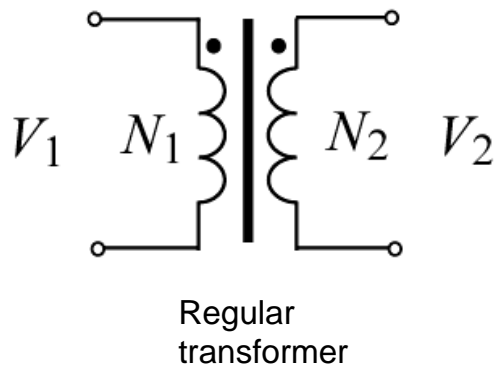

- No electric isolation between primary & secondary
- Safety is a concern
 - 120/110 or 240/120 is OK
 - 12kV/240 or 2.4kV/120 is not safe !
- Smaller than regular transformers
- Economical (material, losses, etc.)

71

Variable Autotransformer - Variac

Often used in Labs as a source of variable AC voltage

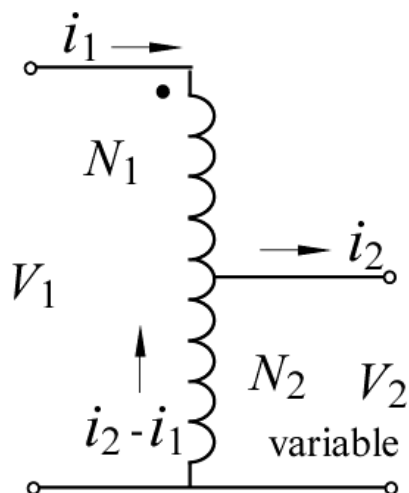

72

Three Phase Transformers

Construction

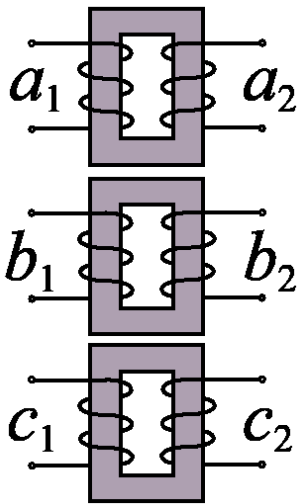

Use 3 transformers
-no magnetic coupling
between phases

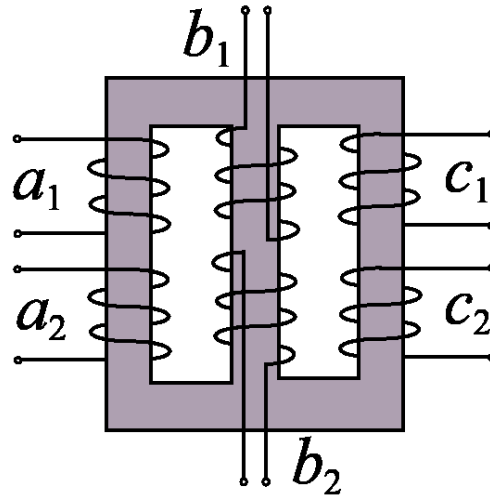

Use 3-phase core
- efficient use of materials

Wye-Wye Connections

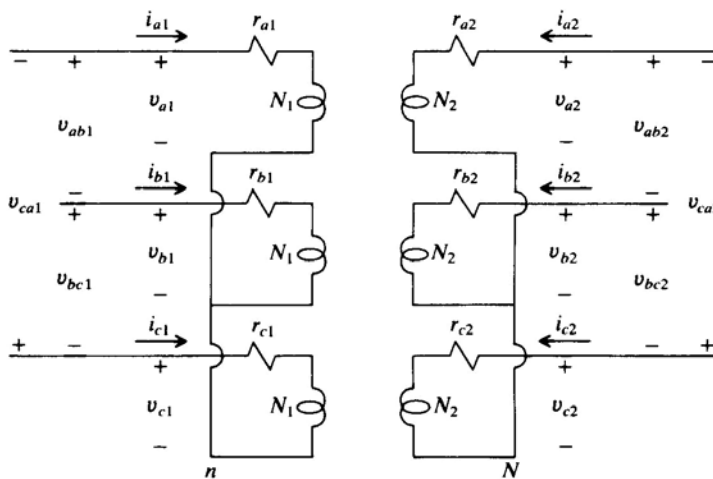

Phase voltages

Line-to-neutral voltages

$$V_{a1}, V_{b1}, V_{c1}$$

Line-to-line voltages

$$V_{ab1} = V_{a1} - V_{b1}$$

$$V_{bc1} = V_{b1} - V_{c1}$$

$$V_{ca1} = V_{c1} - V_{a1}$$

Line and phase
currents are the same

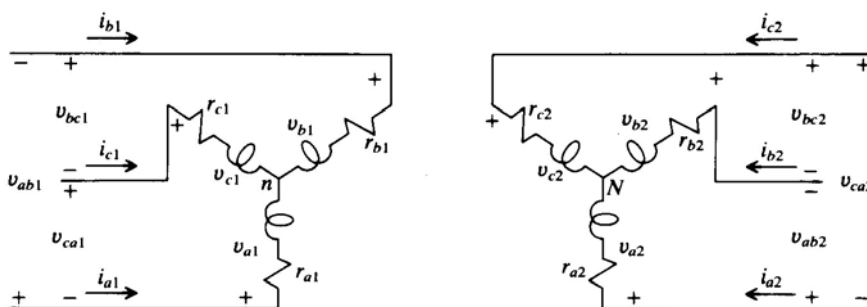

Delta-Delta Connections

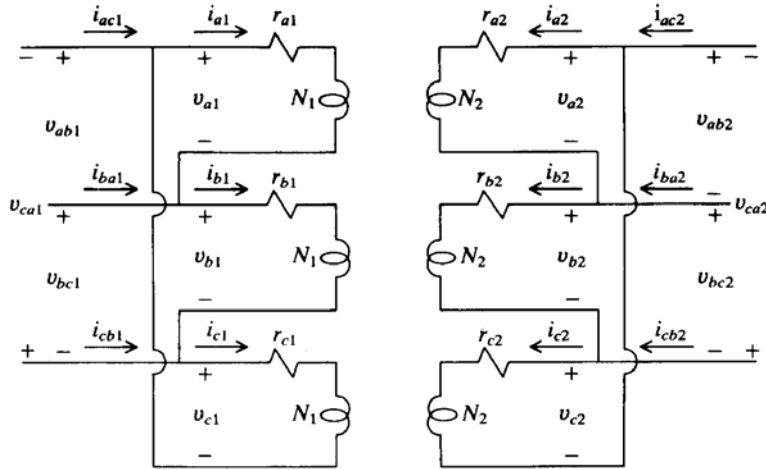

Phase currents

$$i_{a1}, i_{b1}, i_{c1}$$

Line currents

$$i_{ab1}, i_{bc1}, i_{ca1}$$

Line currents

$$i_{ac1} = i_{a1} - i_{c1}$$

$$i_{ba1} = i_{b1} - i_{a1}$$

$$i_{cb1} = i_{c1} - i_{b1}$$

Line and phase voltages are the same

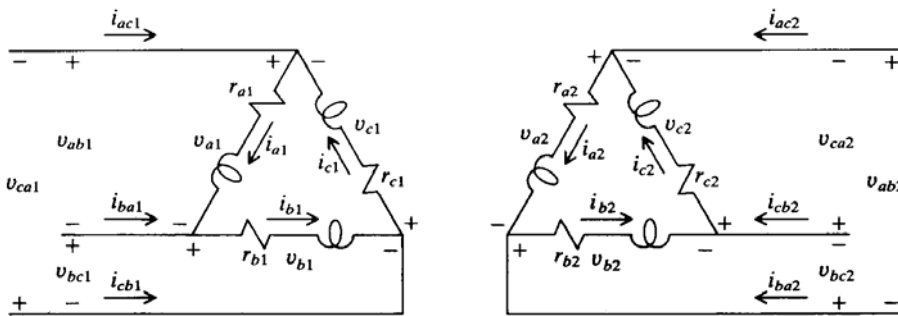

Wye-Delta (or Delta-Wye) Connections

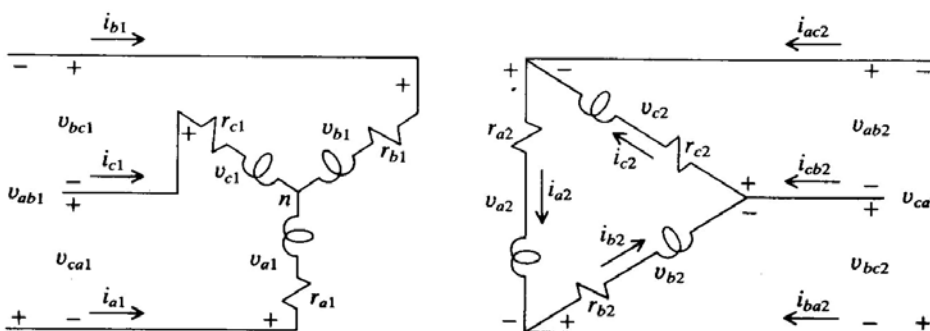
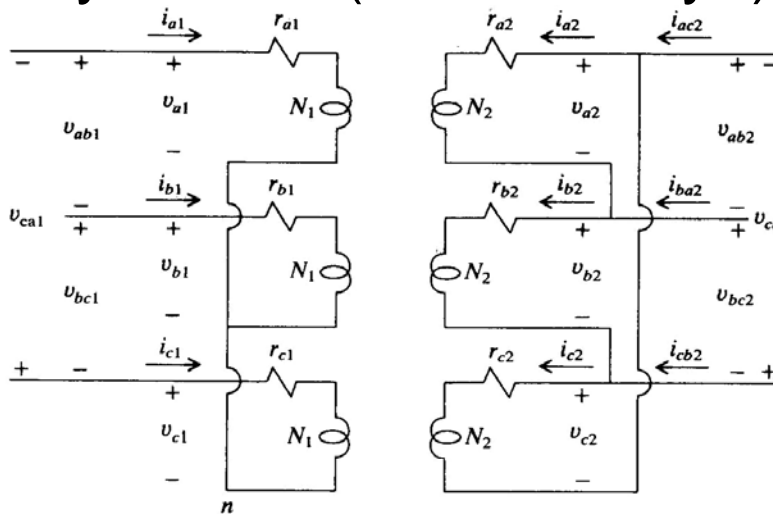

For Ideal Transformer

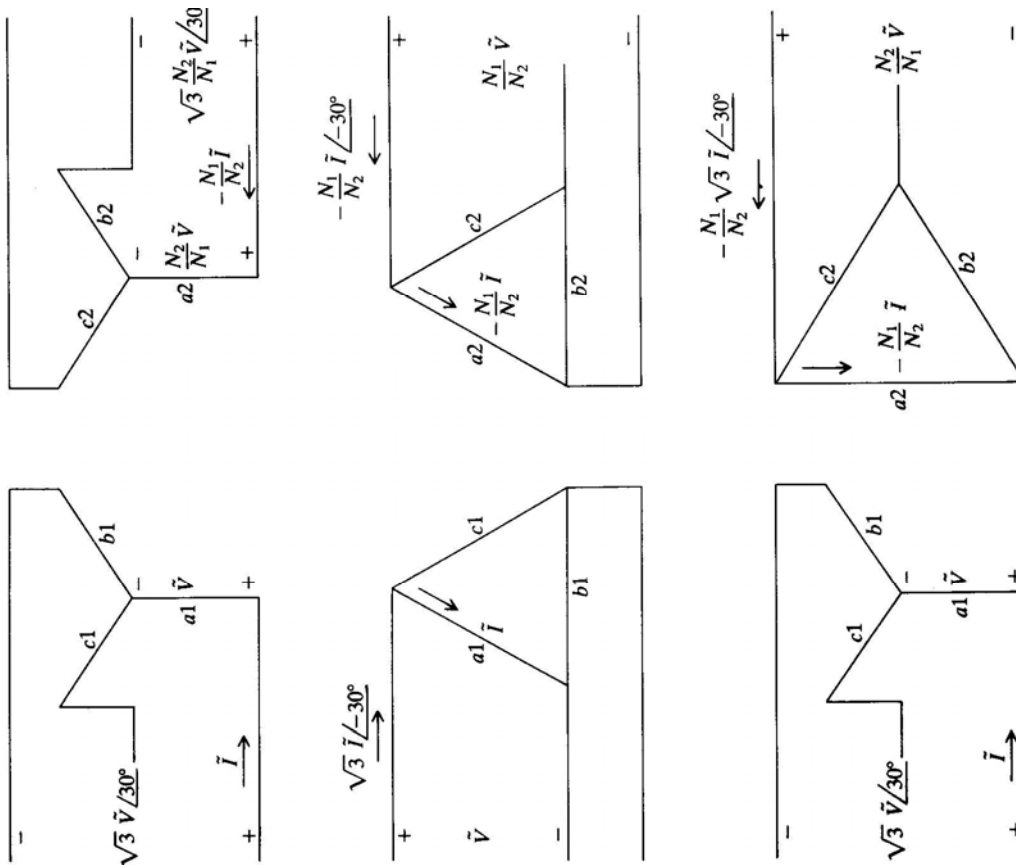

77

Module 1, Part 4

Basic Magnetic Systems with Motion (Chap. 1.7)

Most Important Topics and Concepts

- Basic linear devices
- Concept of position-dependent reluctances & inductances in linear devices
- Mechanical and electrical inputs/outputs
- Basic rotating devices, windings in relative motion
- Magnetic axes
- Concept of position-dependent reluctances & inductances in rotating devices

78

Elementary Electromagnet

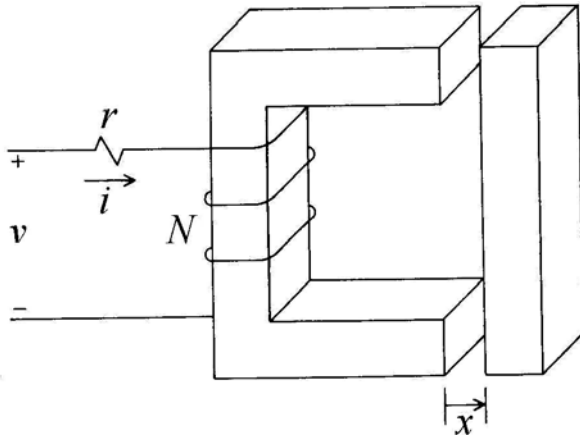

Voltage equation
(Faraday's law + KVL)
$$v = ri + \frac{d\lambda}{dt}$$

Flux linkage
$$\lambda = N\Phi = N(\Phi_m + \Phi_l)$$

$$\Phi_l = Ni/\mathcal{R}_l$$
 - Flux leakage

$$\Phi_m = Ni/\mathcal{R}_m$$
 - Magnetizing flux

Flux linkage & inductances

$$\lambda = \left(\frac{N^2}{\mathcal{R}_l} + \frac{N^2}{\mathcal{R}_m} \right) i = (L_l + L_m) i$$

L_l - Leakage inductance
(assume constant)

L_m - Magnetizing inductance
(depends of position x)

79

Elementary Electromagnet

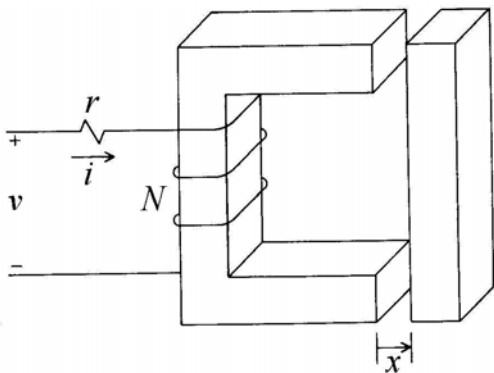

Consider Magnetizing Path

$$\mathcal{R}_m = \mathcal{R}_c + 2\mathcal{R}_g$$

$$\mathcal{R}_c = \frac{l_c}{\mu_r \mu_0 A_c}$$
 - Reluctance of the stationary + movable core

$$\mathcal{R}_g(x) = \frac{x}{\mu_0 A_g}$$
 - Reluctance of the air-gap

Assume $A_c = A_g = A$ we get

$$\mathcal{R}_m(x) = \frac{1}{\mu_0 A} \left(\frac{l_c}{\mu_c} + 2x \right)$$

Magnetizing inductance

$$L_m = \frac{N^2}{\mathcal{R}_m} = N^2 \mu_0 A \frac{1}{(l_c/\mu_c + 2x)} = \frac{k_1}{k_2 + x}$$

80

Elementary Electromagnet

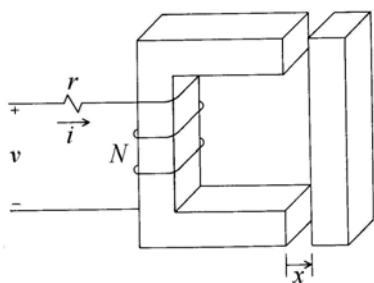

Magnetizing Inductance

$$L_m = N^2 \mu_0 A \frac{1}{(l_c / \mu_c + 2x)} = \frac{k_1}{k_2 + x}$$

where $k_1 = \frac{N^2 \mu_0 A}{2}$ and $k_2 = \frac{l_c}{2\mu_c}$

Voltage Equation

$$v = ri + \frac{d\lambda}{dt} \quad \text{where} \quad \lambda(i, x) = L(x)i = [L_l + L_m(x)]i$$

$$\lambda' = L'i + Li' = \frac{dL}{dt}i + L\frac{di}{dt} = \frac{\partial L}{\partial x} \frac{dx}{dt}i + L\frac{di}{dt}$$

And finally we get $v = ri + \left[\frac{\partial L_m(x)}{\partial x} \frac{dx}{dt} \right]i + [L_l + L_m(x)]\frac{di}{dt}$

81

Elementary Electromagnet

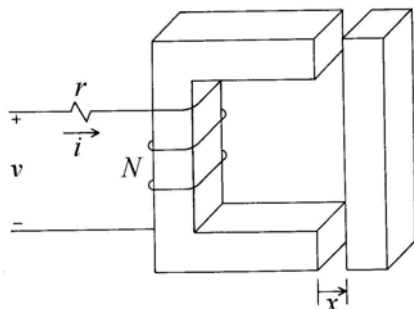

The elementary electromagnet is very similar to a plunger solenoid (Lab-1)

How do we solve Voltage Equation ?

$$v = ri + \left[\frac{dL_m(x)}{dx} \frac{dx}{dt} \right]i + [L_l + L_m(x)]\frac{di}{dt}$$

What is $\frac{dx}{dt}$

$$\frac{di}{dt} = [L_l + L_m(x)]^{-1} \left\{ v - \left[r + \frac{\partial L_m(x)}{\partial x} \frac{dx}{dt} \right]i \right\}$$

Need dynamic equation of mechanical system !

82

Other Reluctance Devices

Plunger solenoid (Lab-1)



Closed-frame tubular solenoid

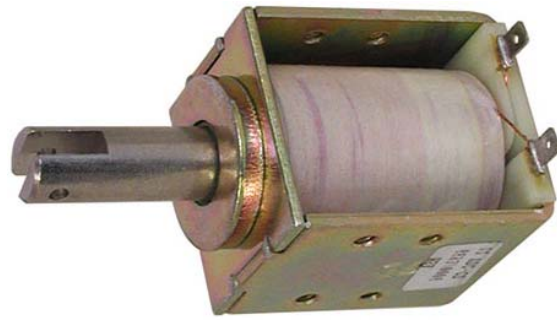

Open-frame solenoid

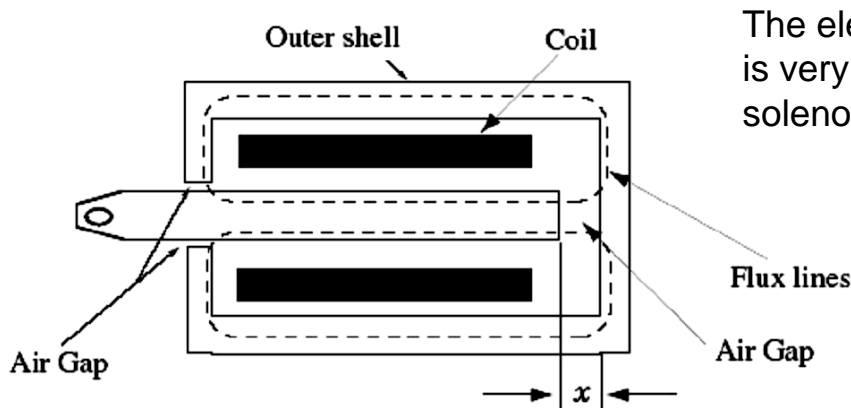

The elementary electromagnet is very similar to a plunger solenoid (Lab-1)

Other Reluctance Devices

Plunger solenoid

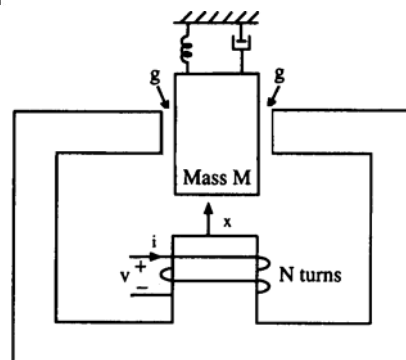
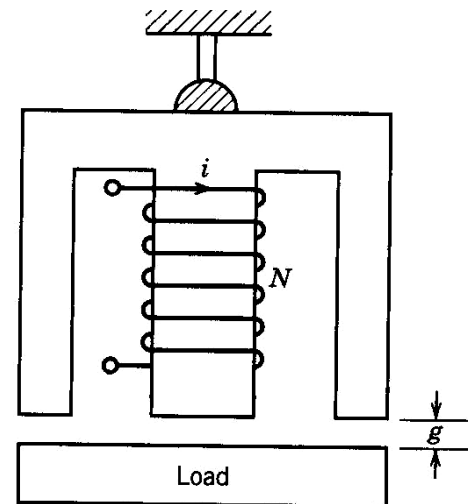
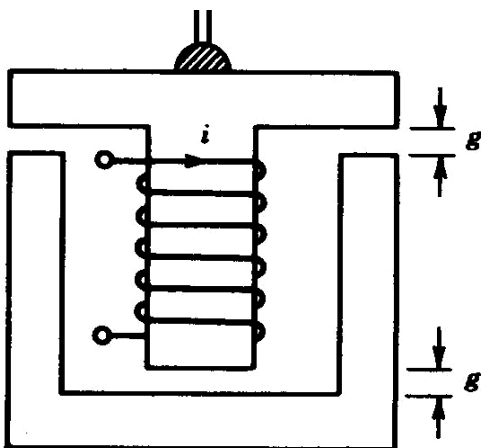

Other Reluctance Devices

Multi-input/output

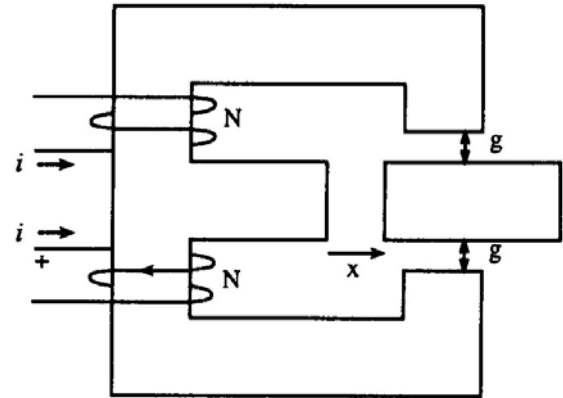
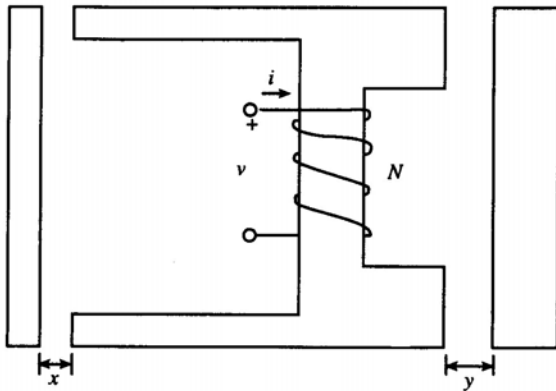

85

Rotating Reluctance Devices

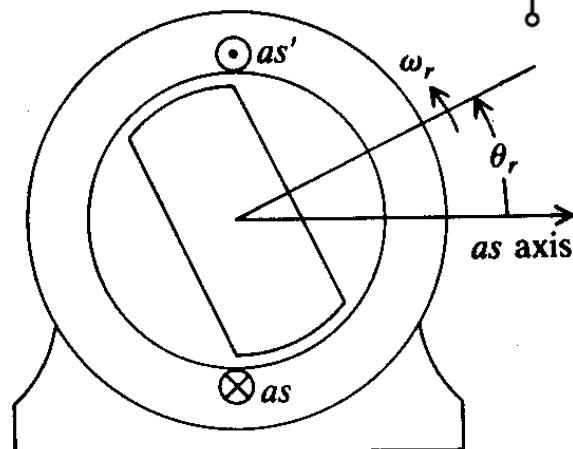
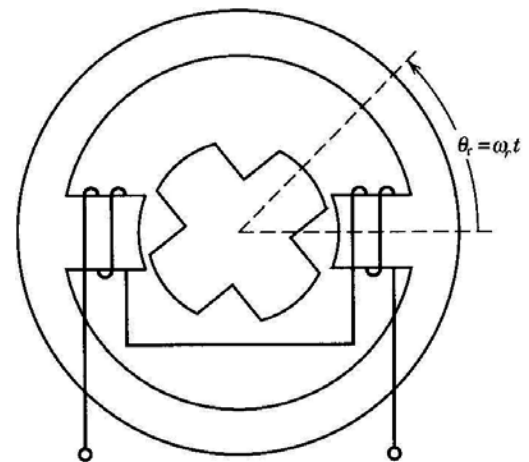
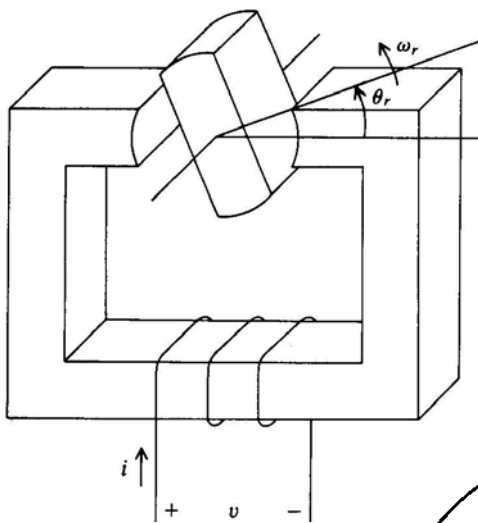

86

Rotating Reluctance Devices

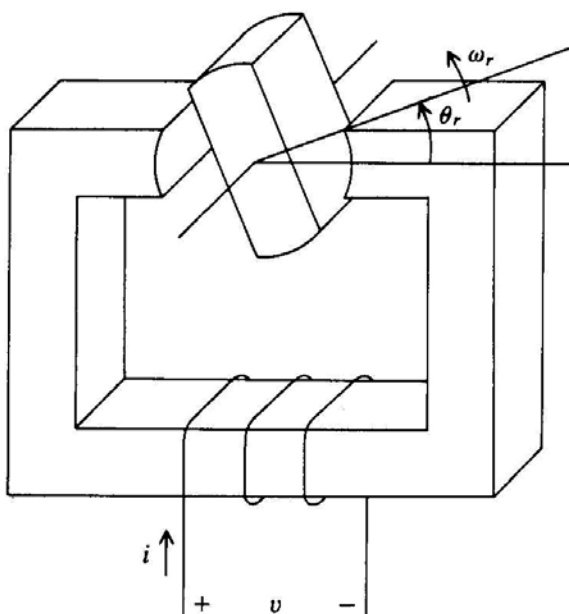

Flux linkage & inductances

$$\lambda = \left(\frac{N^2}{\mathcal{R}_l} + \frac{N^2}{\mathcal{R}_m} \right) i = (L_l + L_m) i$$

Magnetizing inductance

$$L_m = L_m(\theta_r) = \frac{N^2}{\mathcal{R}_m(\theta_r)}$$

$\mathcal{R}_m(0)$ - Maximum reluctance

$\mathcal{R}_m(\pi/2)$ - Minimum reluctance

87

Rotating Reluctance Devices

Approximation of Magnetizing Inductance

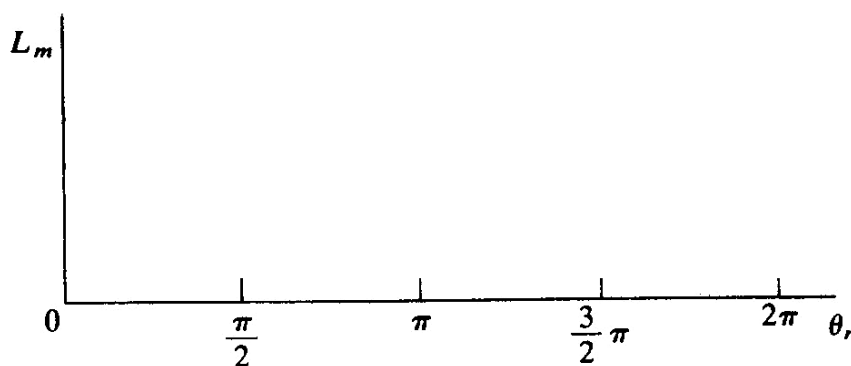
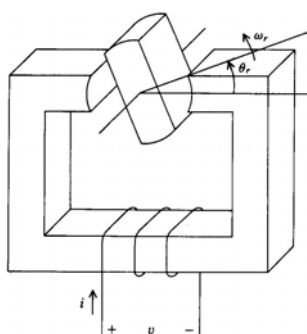

$$L_m(\theta_r) = L_A - L_B \cos(2\theta_r)$$

Resulted Self-Inductance

$$L_m(0) = L_A - L_B$$

$$L_m(\pi/2) = L_A + L_B$$

88

Rotating Reluctance Devices

Approximation of Magnetizing Inductance

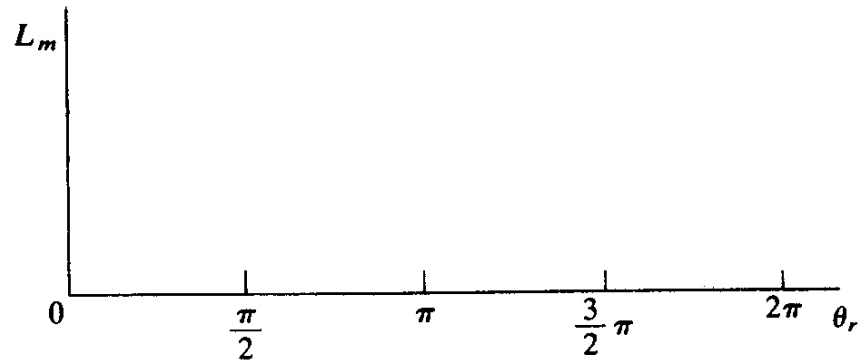
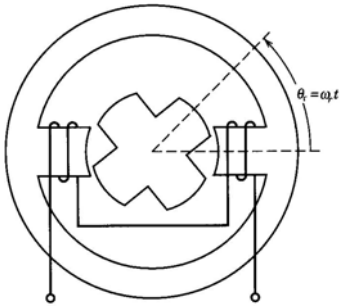

$$L_m(\theta_r) =$$

Resulted Self-Inductance

$$L_m(0) =$$

$$L_m$$

Windings in Relative Motion

Stator Winding Magnetic Axis

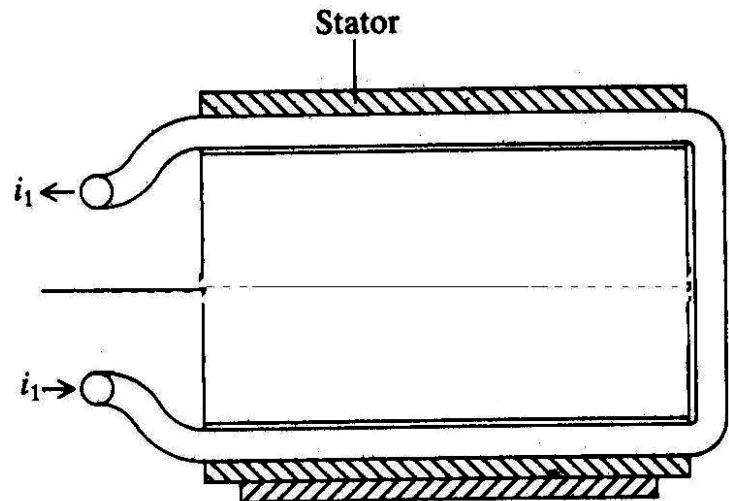
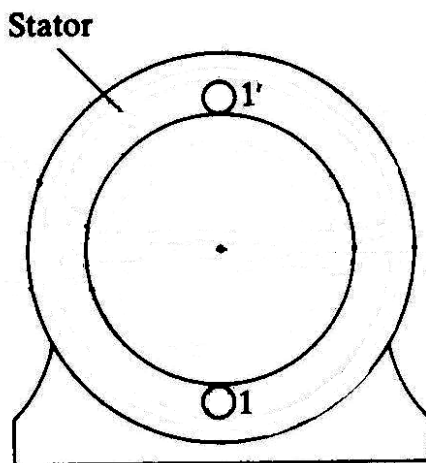

Windings in Relative Motion

Stator & Rotor Winding Magnetic Axes

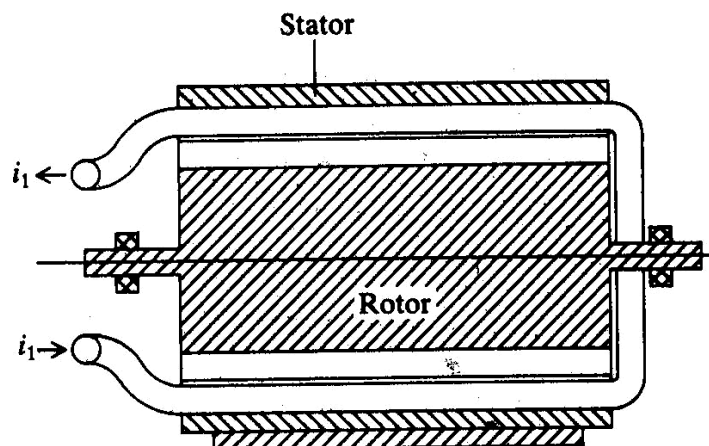
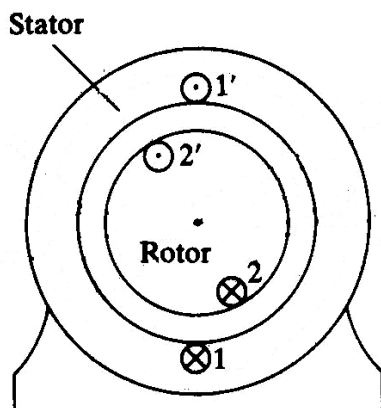

91

Windings in Relative Motion

Stator & Rotor Winding Magnetic Axes

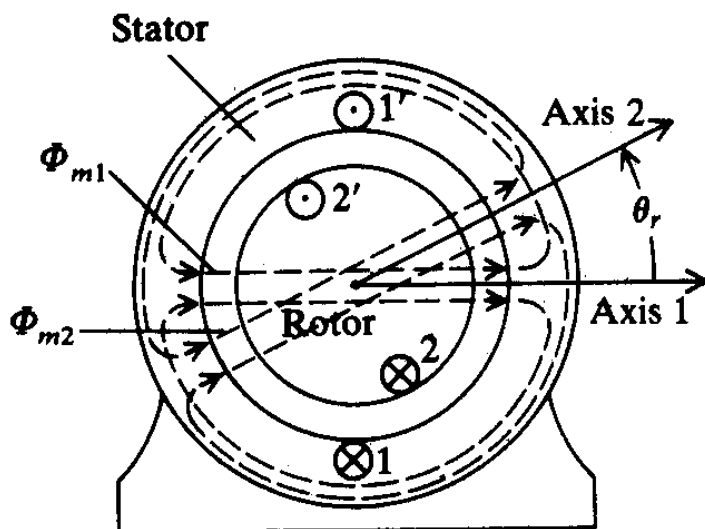

Voltage Equations
- similar to transformer

$$v_1 = r_1 i_1 + \frac{d\lambda_1}{dt}$$

$$v_2 = r_2 i_2 + \frac{d\lambda_2}{dt}$$

Flux linkages

$$\lambda_1 = L_{11} i_1 + L_{12} i_2$$

$$\lambda_2 = L_{22} i_2 + L_{21} i_1$$

92

Windings in Relative Motion

Stator & Rotor Inductances

Self-inductances

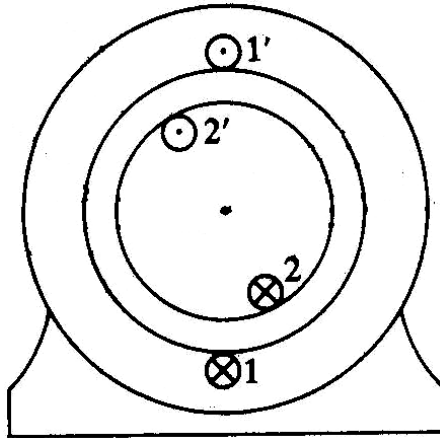

$$L_{11} = L_{l1} + L_{m1} \text{ and } L_{22} = L_{l2} + L_{m2}$$

Mutual-inductances

$$L_{12} = L_{21} = L_{12}(\theta_r)$$

$$L_{12}(0)$$

$$L_{12}(\pi/2)$$

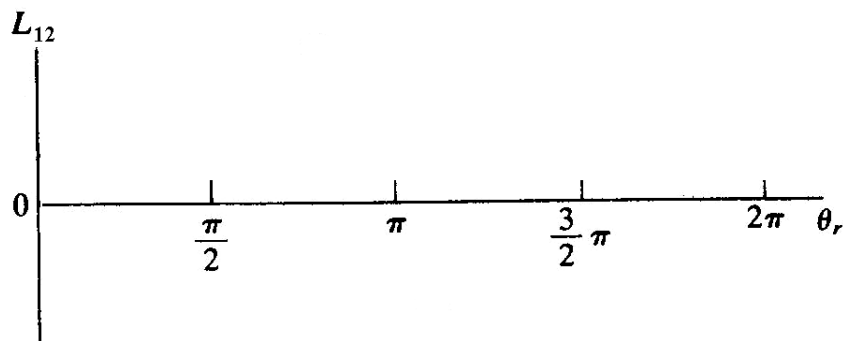

93

Example SP1.7-3

Rotor current changed direction

Self-inductances

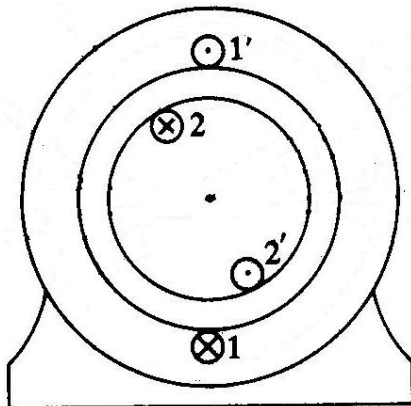

Mutual-inductances

$$L_{12} = L_{21} = L_{12}(\theta_r)$$

$$L_{12}(0)$$

$$L_{12}(\pi/2)$$

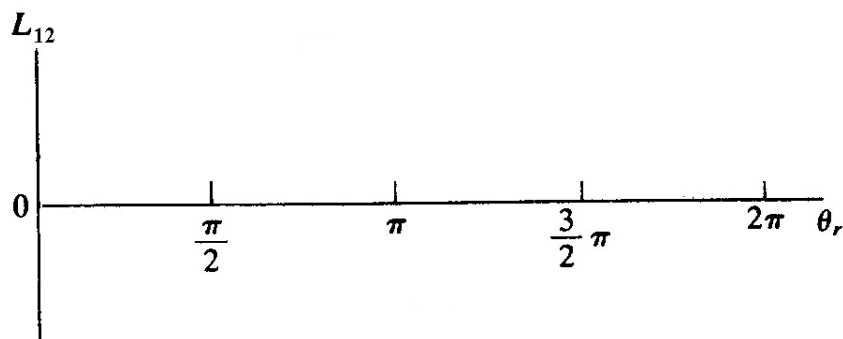

94