

r

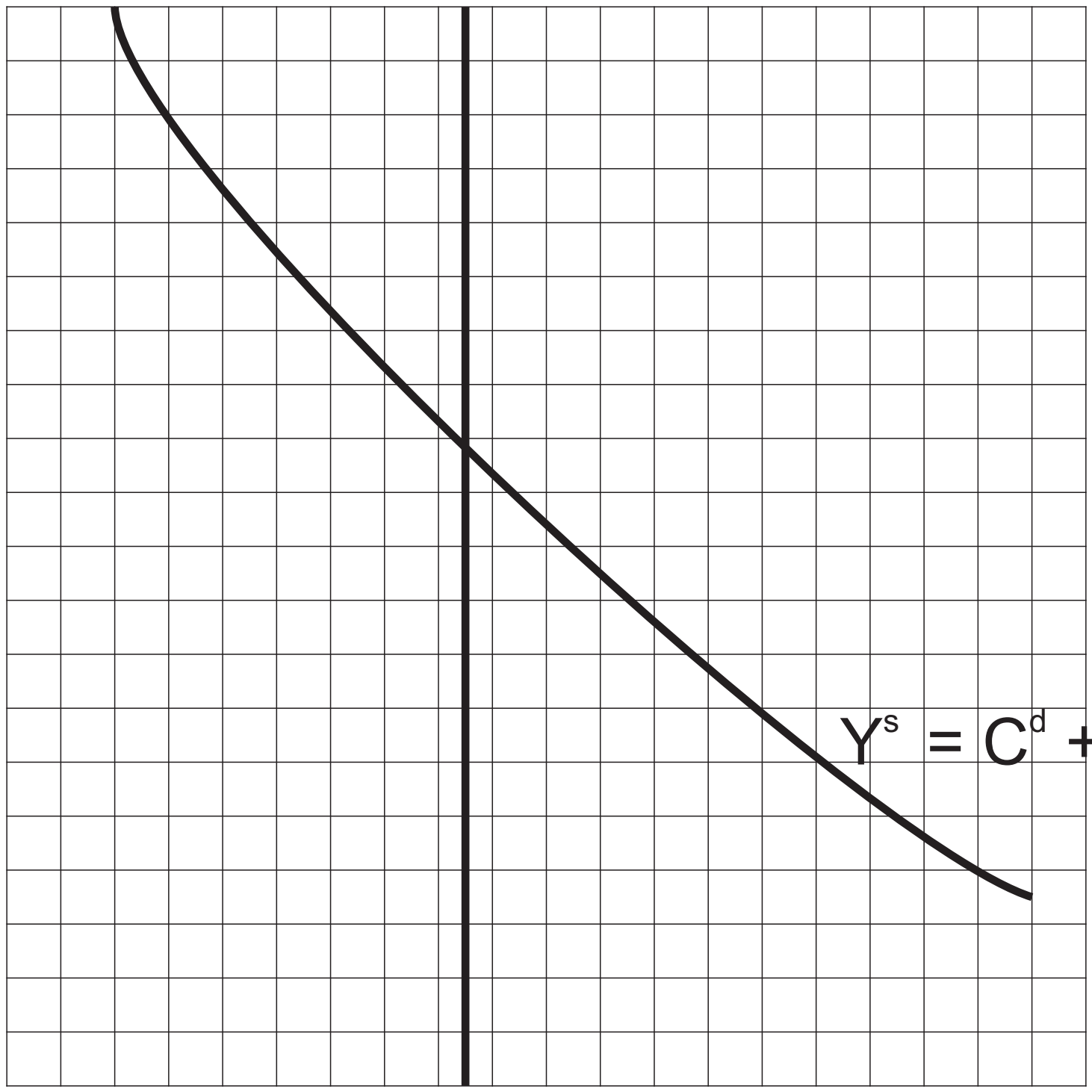

Y

$$Y^s = C^d + I^d + G^d$$

Figure 2. Shift in investment

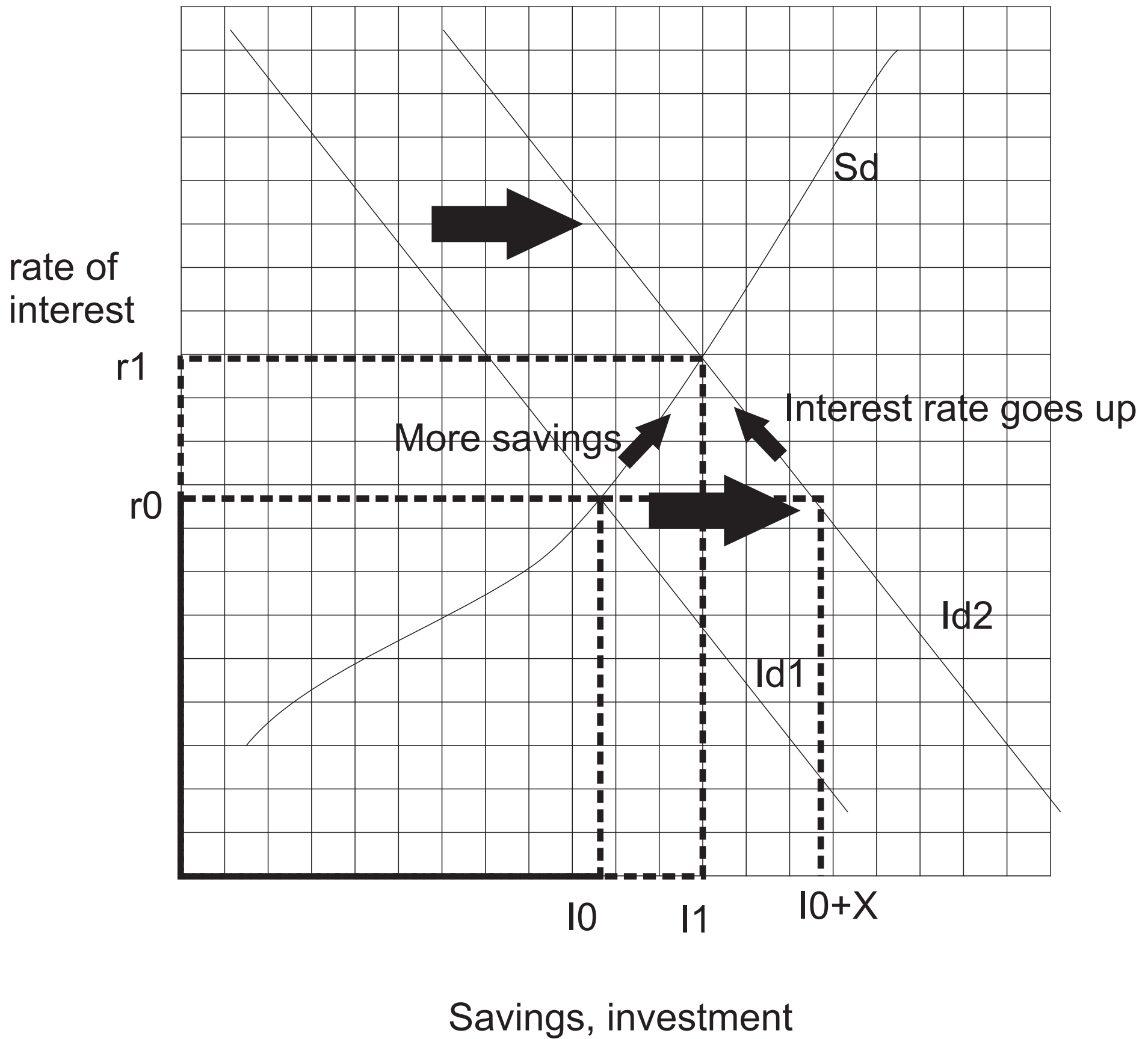

Figure 3. Elasticity's affect on shifts of investment

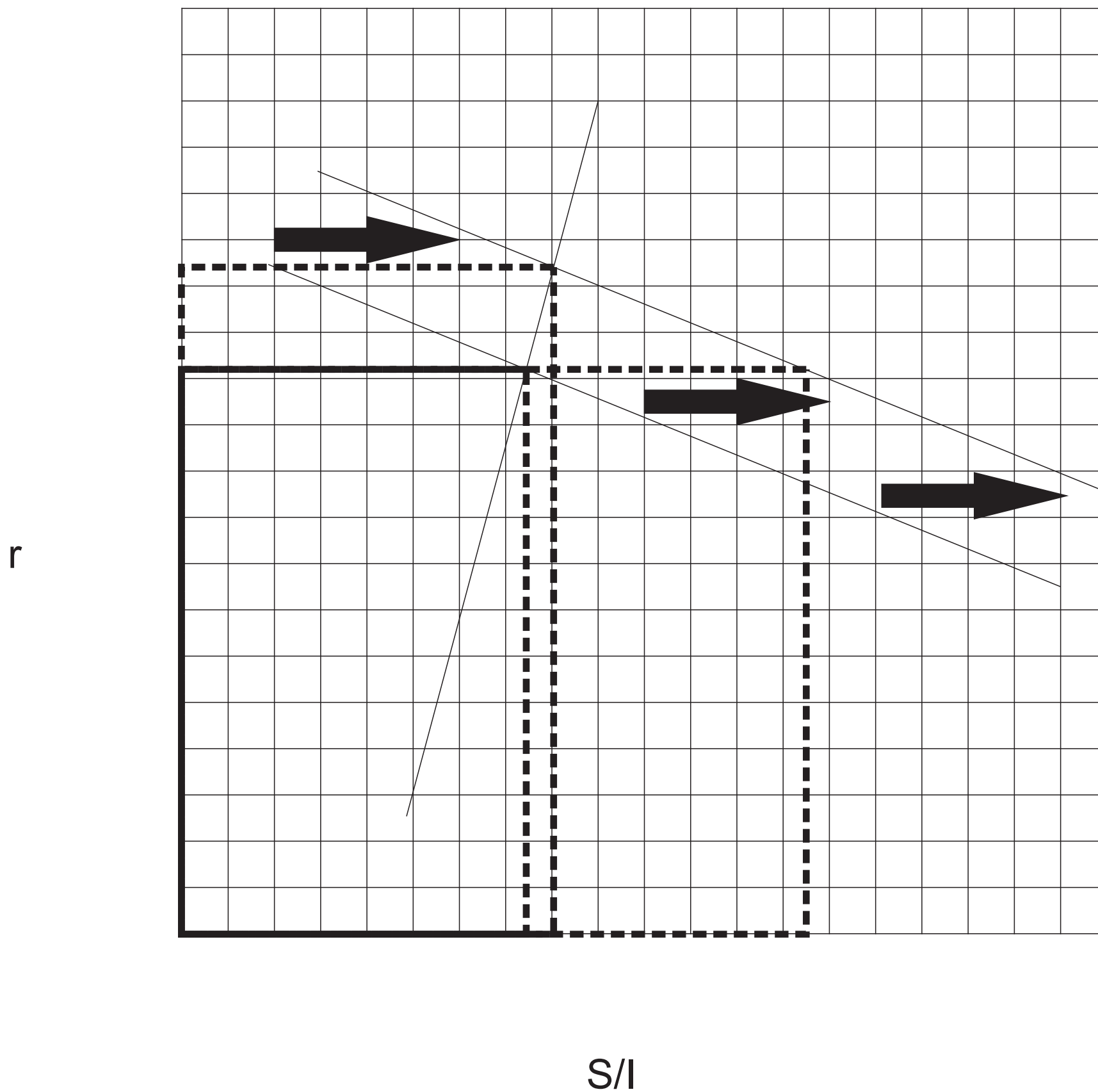

Figure 4. Shift in savings

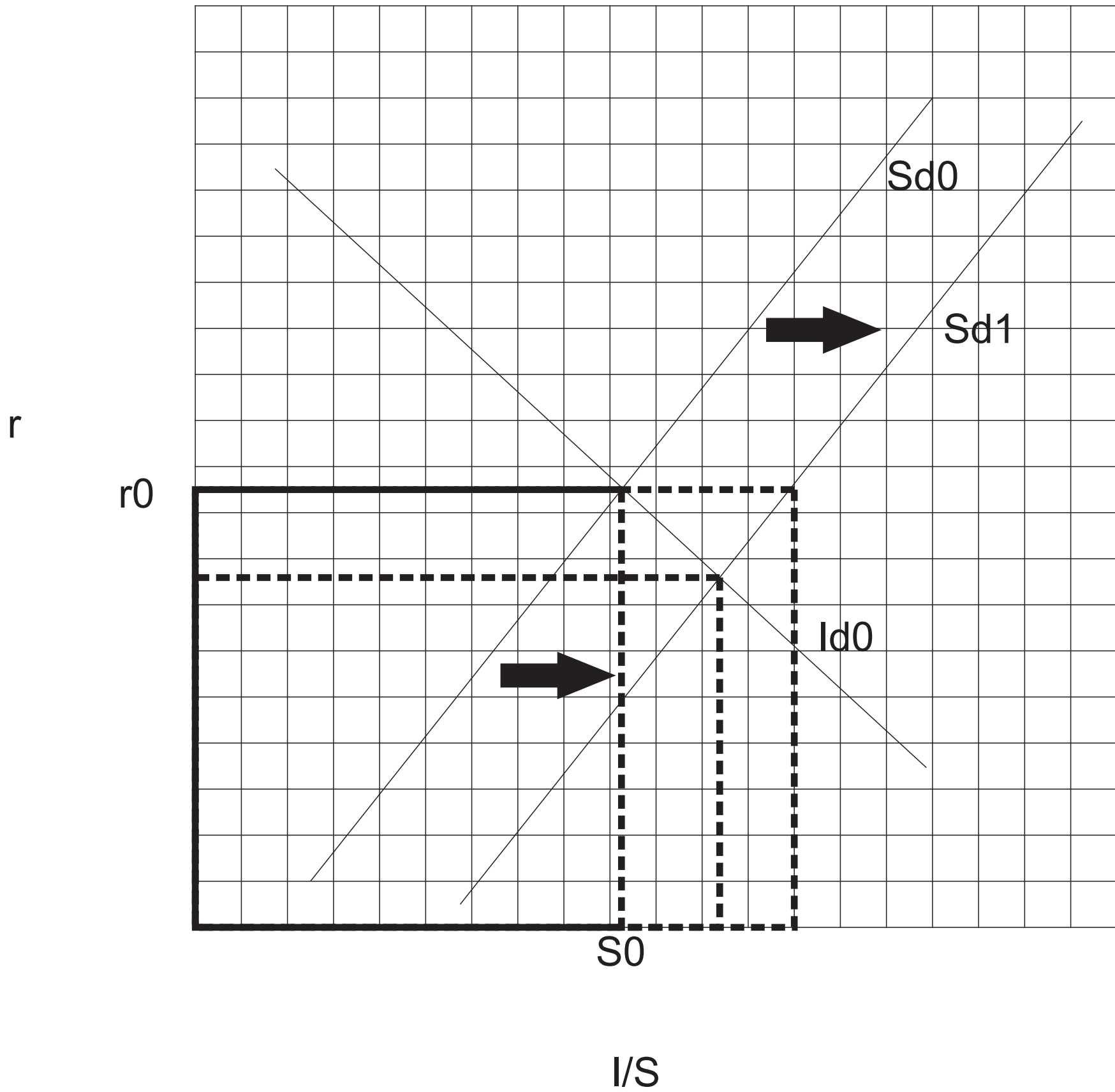

Figure 5. Also increase in supply of savings
(Decrease in interest)

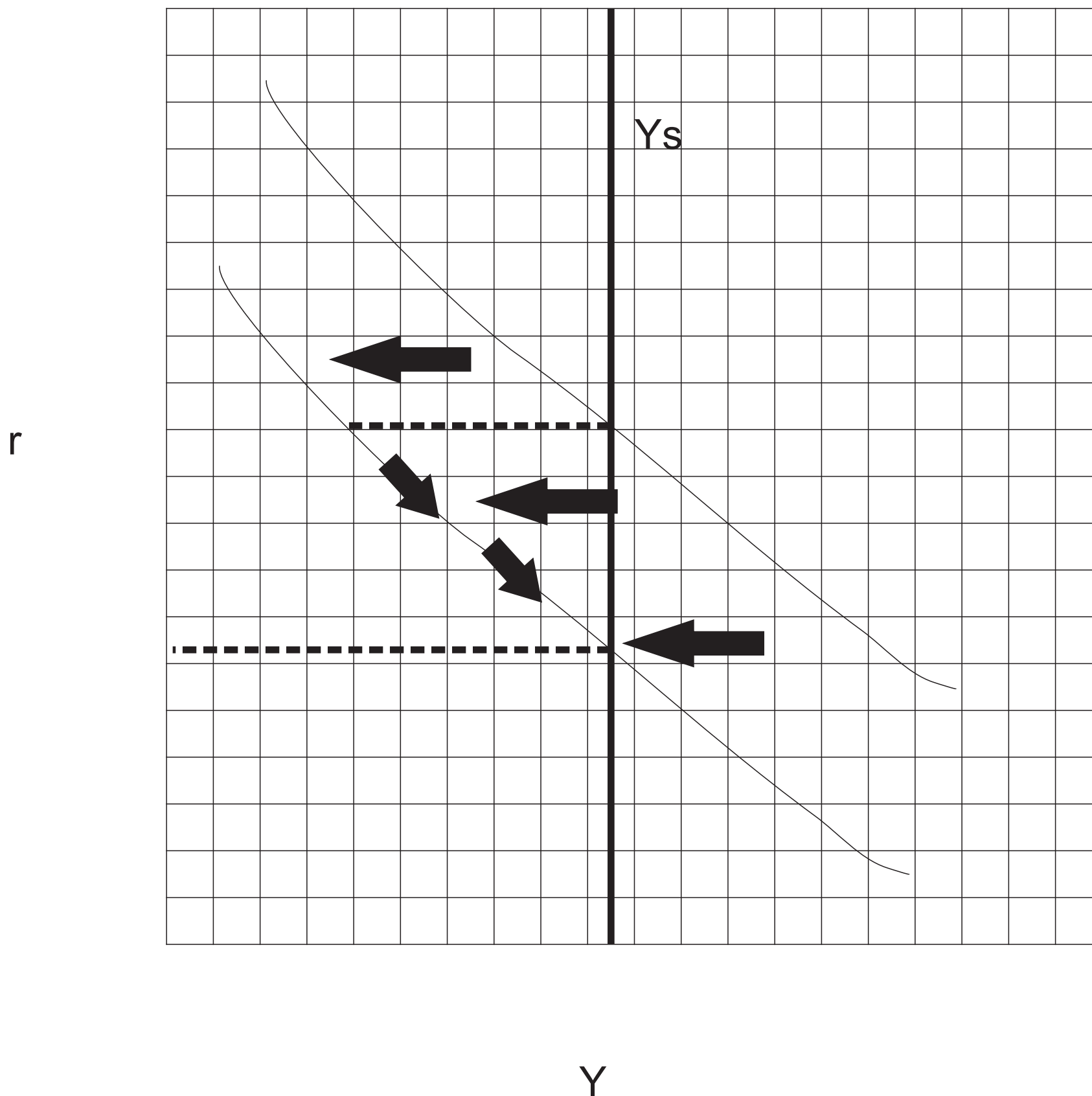

Figure 6. Natural rate of unemployment

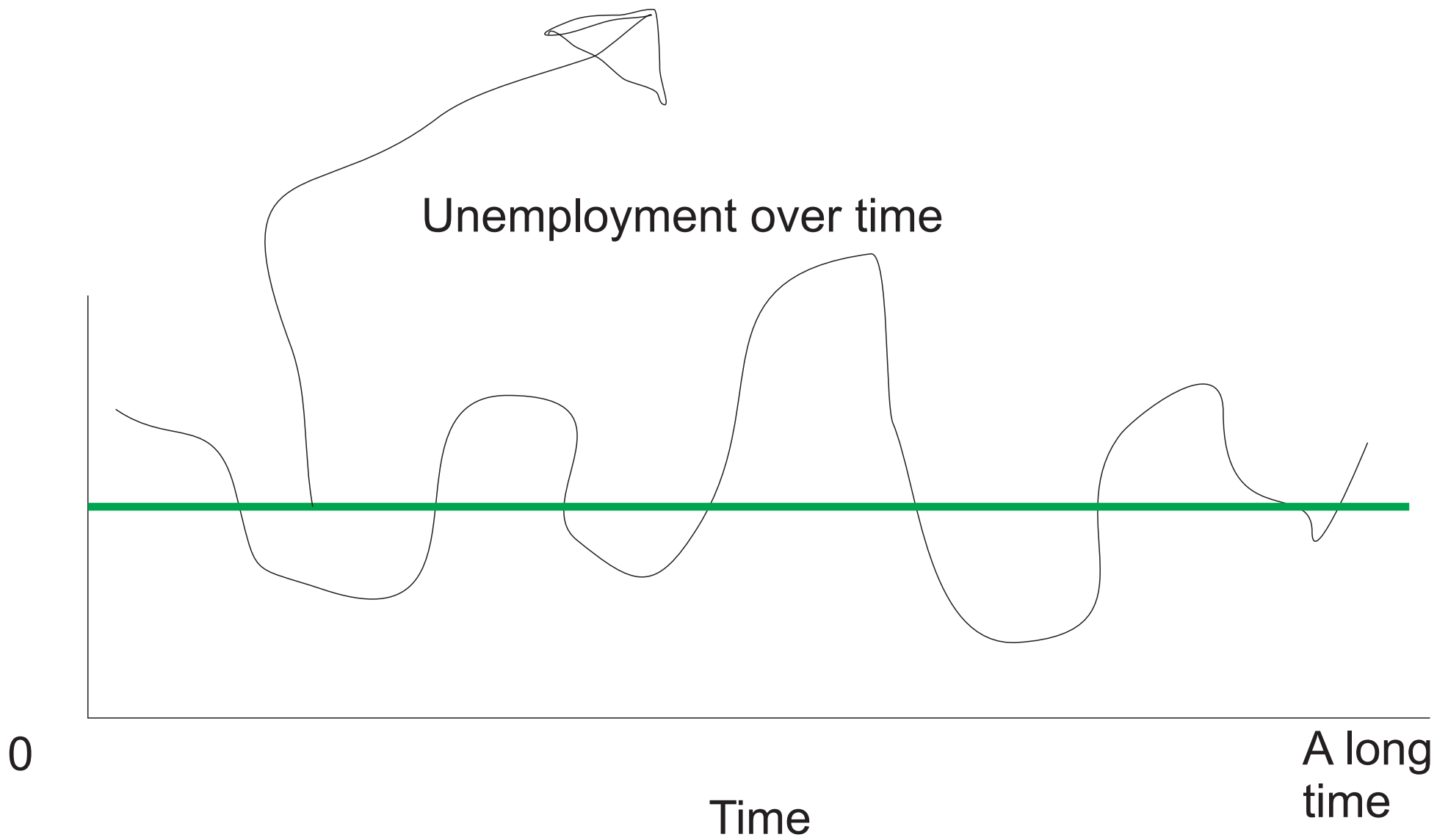

Figure 7. Employment market
Where are the unemployed?

