

Module 2

Resistive Circuits

Chapter 3 in Dorf and Svoboda

Circuit Elements

- Throughout this course, we shall be studying elements with two terminals. These elements are represented generically by the following symbol:

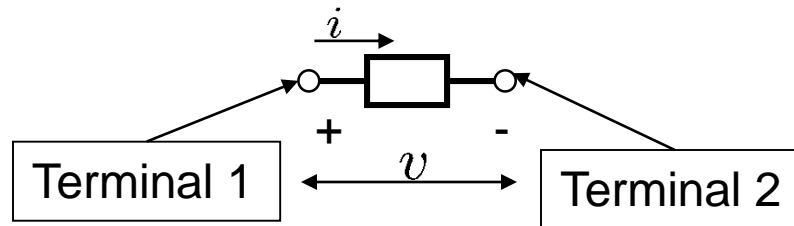

- A circuit element, when existing within a circuit, will have current i flowing between its two terminals and a voltage difference v associated with it.
- There are many types of elements in the domain of electrical engineering and the best way to describe them is to try to classify them.

Classification of Circuit Elements

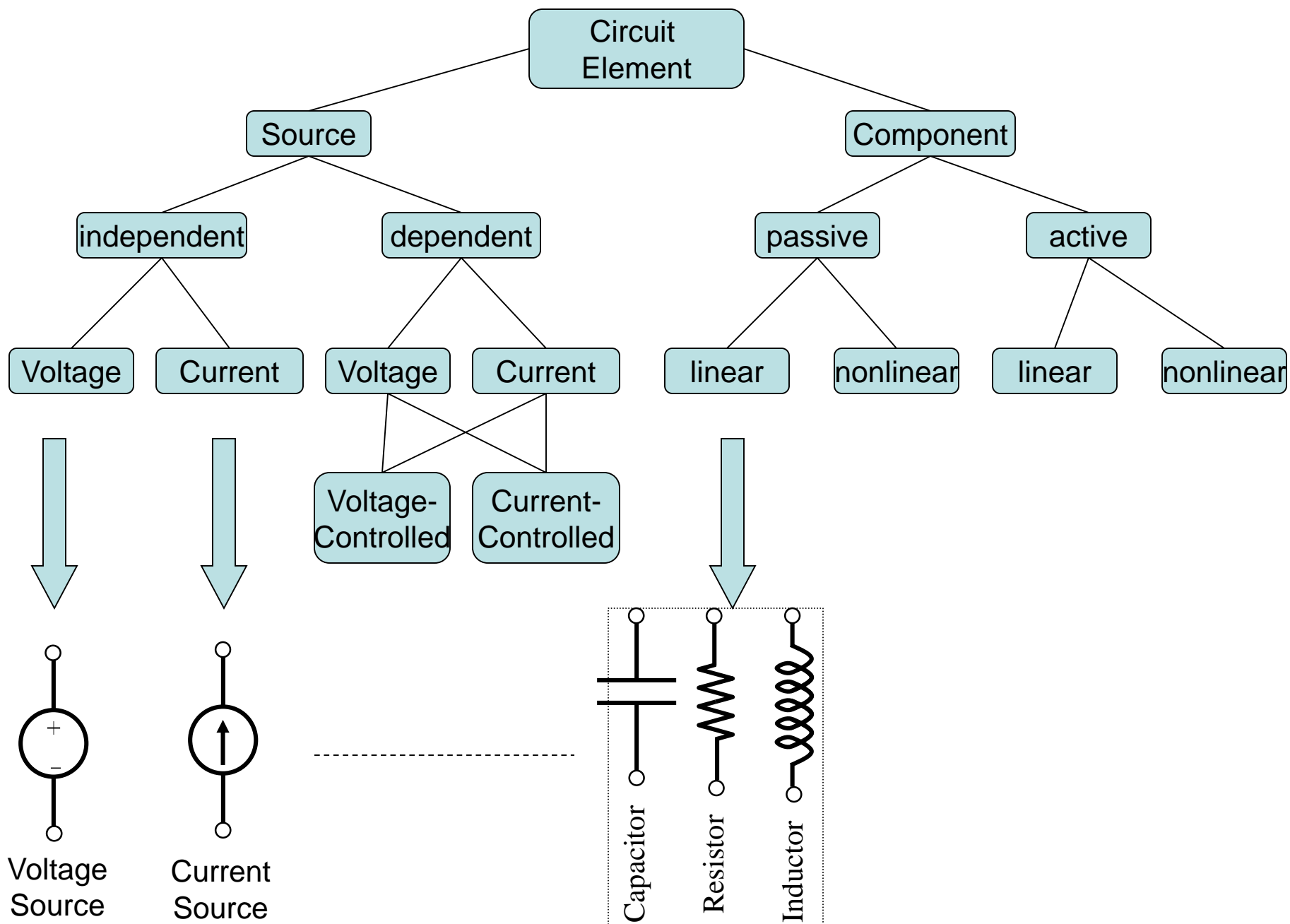

What we will do in this Module

- **We shall focus on the following elements**

- *Independent Voltage Source*
- *Independent Current Sources*
- *Resistors*

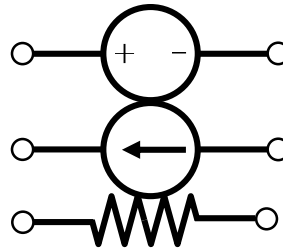

- **Our Objective is:**

- *Analyzing Circuits containing resistors and independent sources (Resistive Circuits), i.e., compute voltages and currents in the different circuit elements*

- **To attain that objective we use the following circuit laws**

- *Ohm's Law*
- *Kirchoff Voltage Law (KVL)*
- *Kirchoff Current Law (KCL)*

- **In our approach:**

- *We shall use examples to explain the concepts as much as possible.*

Before starting,

- **Some Useful Notes**
 - How to connect two circuit elements??
 - Types of connections
 - Examples of Connections

Before Starting

- **Some Useful Notes**

- **How to connect two circuit elements??**

Two circuit elements are said to be *directly connected* when they share the same terminal. The common terminal is then referred to as a *circuit node*.

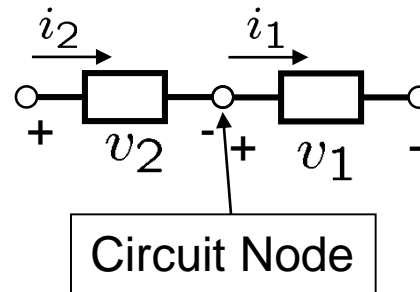

Notice that we can use a wire to connect two terminals together, and in this case the connecting wire is considered part of the node.

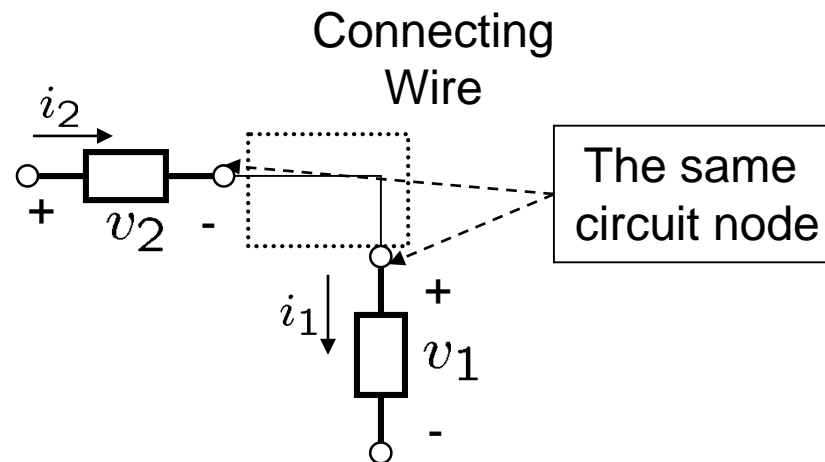

Before Starting

- **Some Useful Notes**

- **TWO Important Types of connections**

- **Series Connections**: Two circuit elements are connected in series when they share at least a single node, such that the currents that flow in both elements are the same.

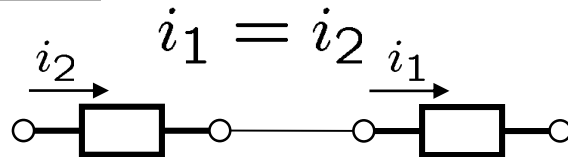

- **Parallel Connections** Two circuit elements are said to be connected in parallel when their two terminals are connected such that their voltages are the same.

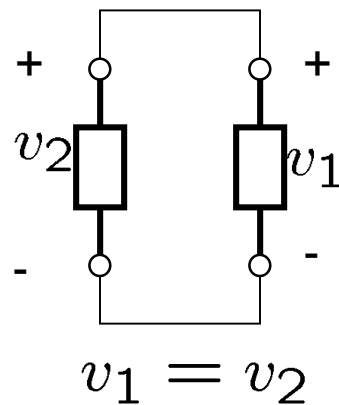

Before Starting

- **Some Useful Notes**

- **Types of connections**

- Is it possible to connect **more than two** elements in parallel or in series??

YES!!! Examples of this

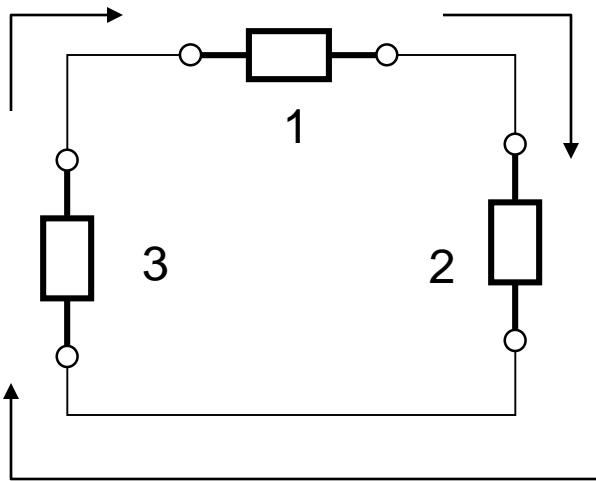

Series Connection

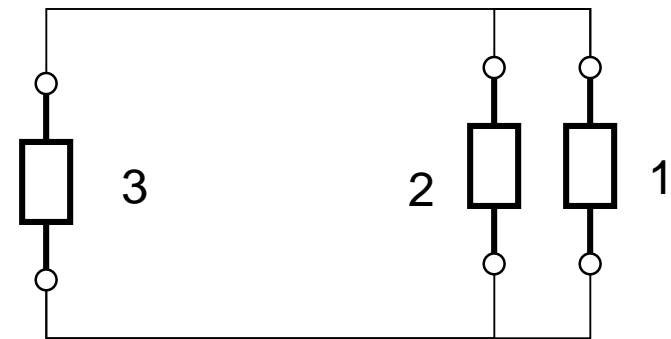

Parallel Connection

An Example Circuit

Find the nodes in the circuit shown below

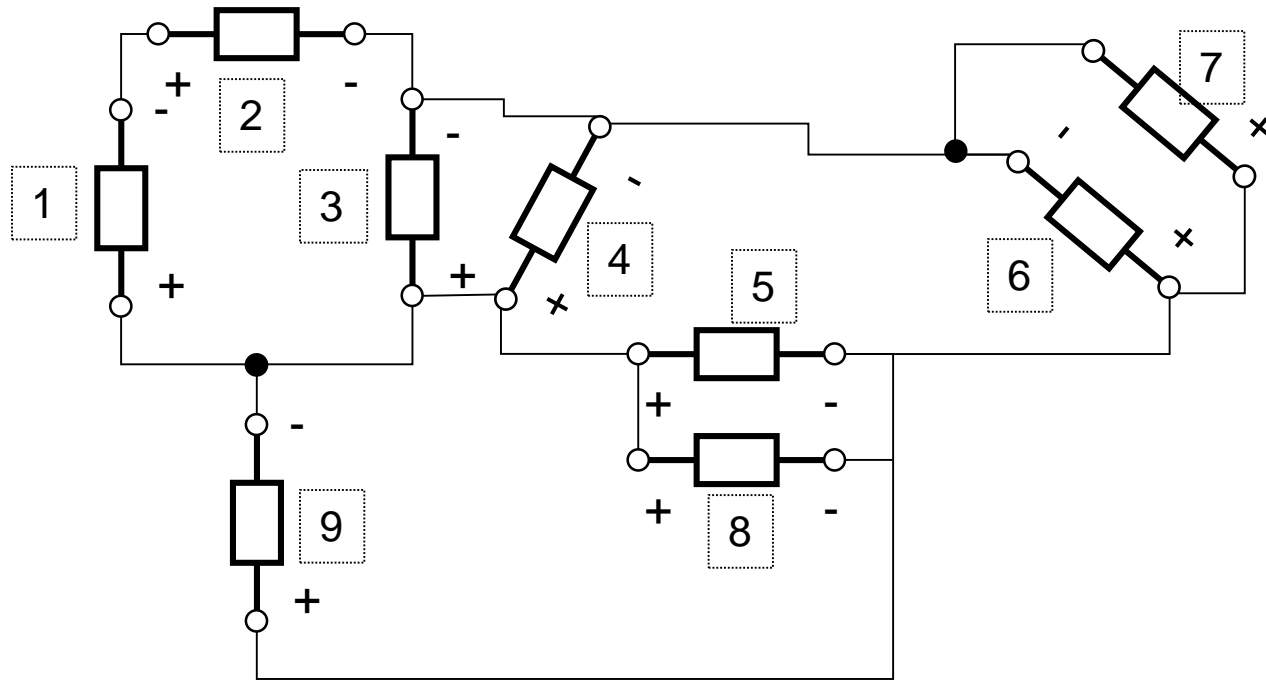

Determine the type of connection between the following elements:

Element1 , Element2	
Element 3 , Element 4	
Element 6 , Element 7	
Element 5 , Element 8 , Element 9	
Element 2 , Element 3	

An Example Circuit

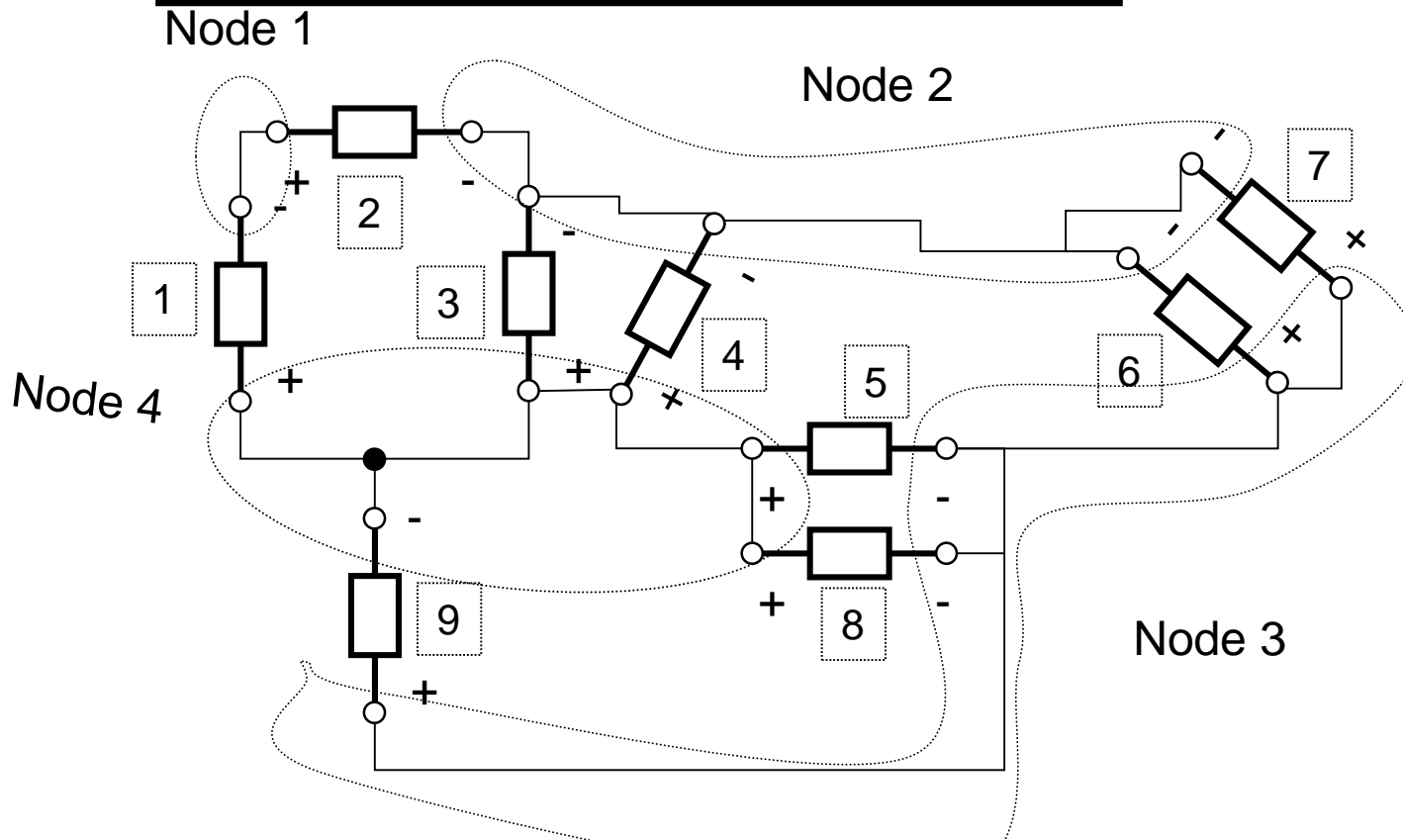

Element 1 , Element 2	
Element 3 , Element 4	
Element 6 , Element 7	
Element 5 , Element 8 , Element 9	
Element 2 , Element 3	

An Example Circuit

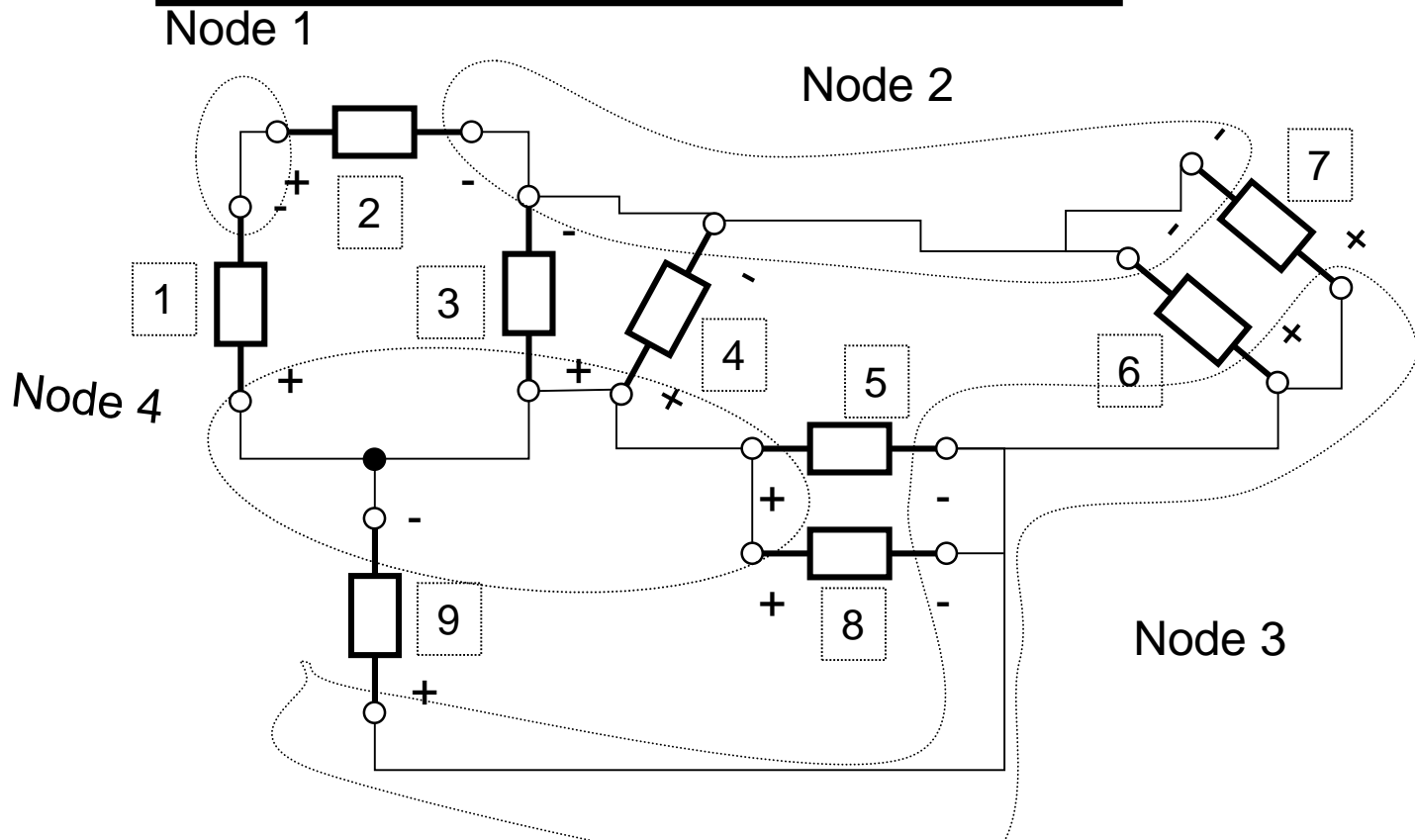

Element1 , Element2	Series
Element 3 , Element 4	Parallel
Element 6 , Element 7	Parallel
Element 5 , Element 8 , Element 9	Parallel
Element 2 , Element 3	Neither in Series Nor in Parallel

Another Exercise circuit

What is the **difference** between the following two circuits

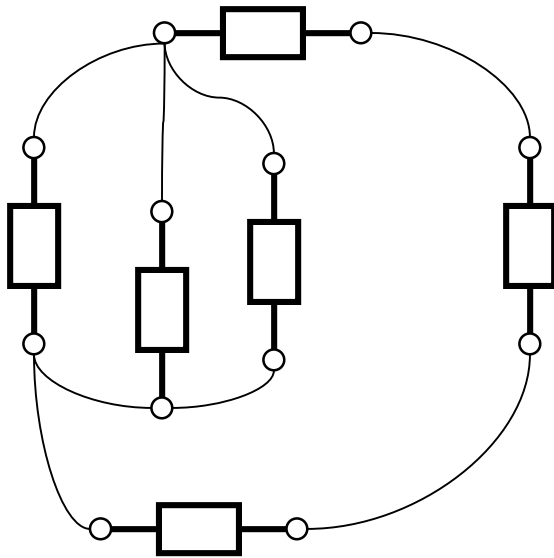

Circuit 1

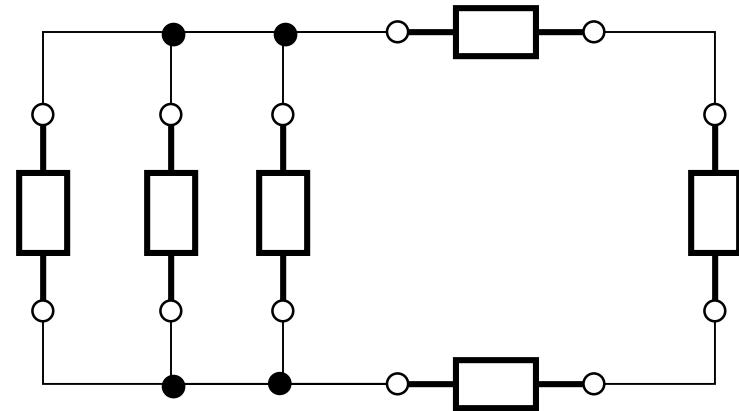

Circuit 2

NONE

The two circuits are exactly the same as they have the same number of nodes as well the same elements. However, it is by convention that connecting wires are always drawn by straight lines such as in Circuit 2. It also makes the schematic more stylish! ;-)

Back to Resistive Circuits

In this module, we are mainly concerned about the case where the circuit elements are **ONLY** one of the following types

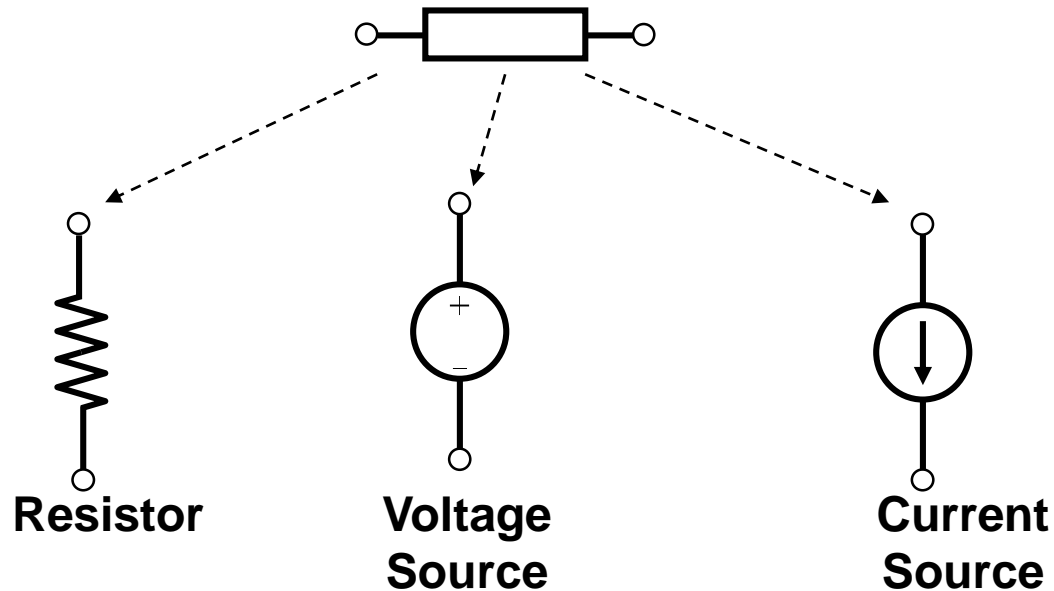

Our objective is to **ANALYZE** a general circuit such as the one shown below.

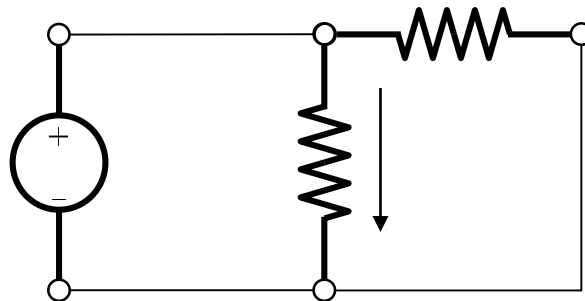

Elements Characteristics

1. Resistor

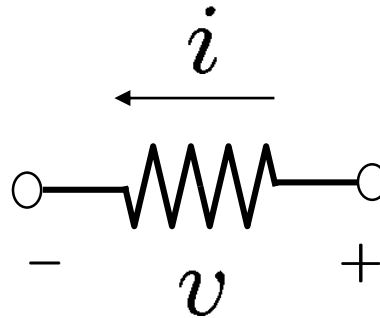

A resistor has a resistance value of

$$R$$

Measured in Ohm Ω

By Ohm's law we have $i = \frac{v}{R}$ OR $v = iR$

One way to read Ohm's Law is by interpreting it as follows.

A current flowing from one resistor's terminal to the other terminal generates a voltage difference of $(I \times R)$. Or, put differently, if the voltage difference v existed between resistor terminals, it will generate current $i = v/R$

Elements Characteristics

2. Voltage Source

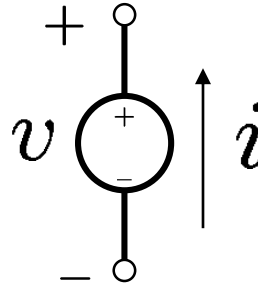

A voltage source has a predefined value of voltage E

Measured in Volts (V)

A voltage source is a circuit element that has a constant value of voltage (E), e.g. 10 V, across its terminals. To illustrate the operation of a voltage source we connect it with a resistor of $5\ \Omega$ as shown below, and try to find the current flowing through the resistor.

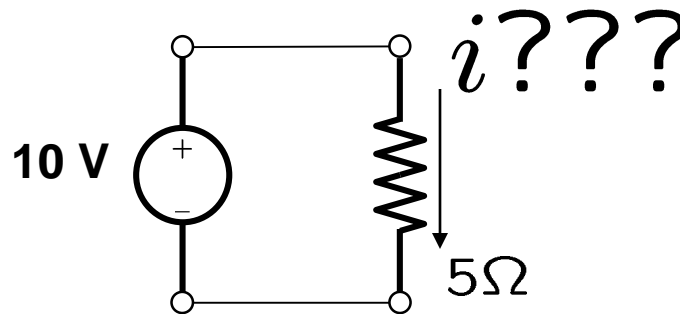

Elements Characteristics

2. Voltage Source

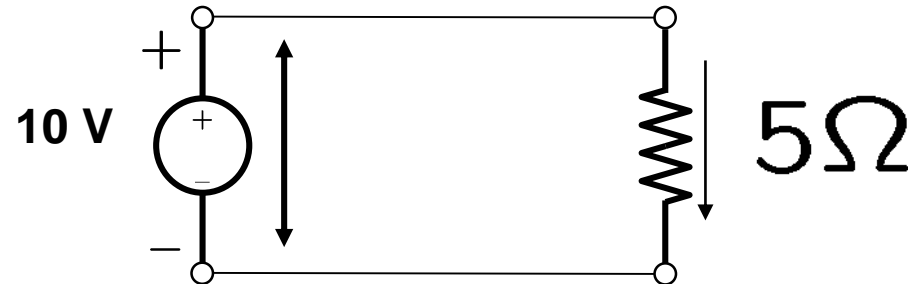

The 10 V will appear across the 5 Ω as shown above and to find the current flowing through the resistor, we just have to apply Ohm's law to calculate the current. In this case, the current will be equal to $10 \text{ V} / 5 \Omega = 2 \text{ A}$.

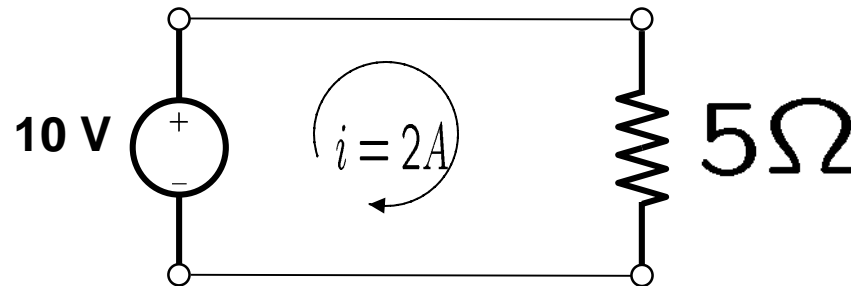

Elements Characteristics

3. Current Source

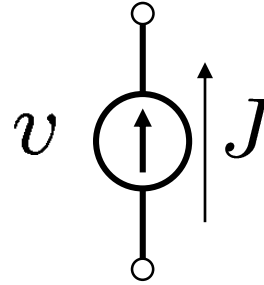

A current source has a predefined value of current J
Measured in Amperes (A)

A current source is a circuit element that has a constant value of current (say J A), e.g. 10 A, flowing between its terminals. To illustrate the operation of a current source, we connect it with a resistor of $5\ \Omega$ as shown below.

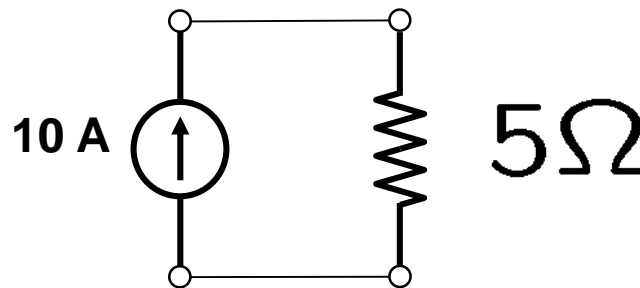

Elements Characteristics

3. Current Source

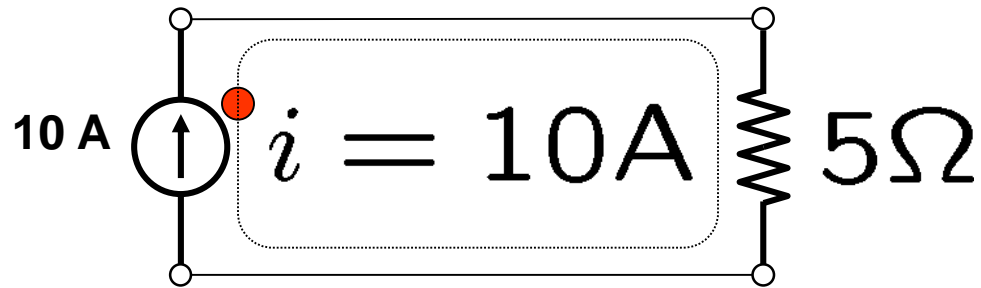

The current source will force 10 A directly into the resistor. By Ohm's law, the flowing current in the resistor will generate a voltage of $10 \times 5 = 50\text{ V}$ across the resistor. This is the same voltage across the current source.

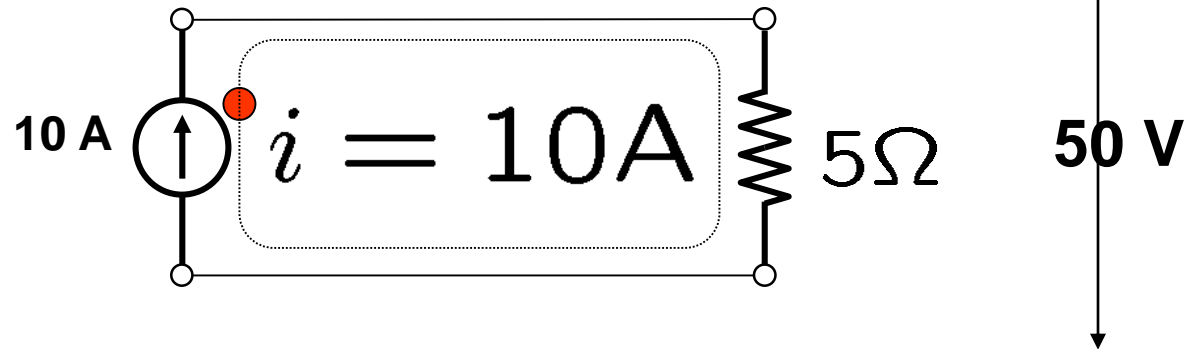

IMPORTANT

NOTE

**About Independent
(Voltage/Current)
Sources**

CAUTION

IMPORTANT NOTE

In a voltage source, the voltage value across the element is KNOWN and is equal to the source value

$$v = E$$

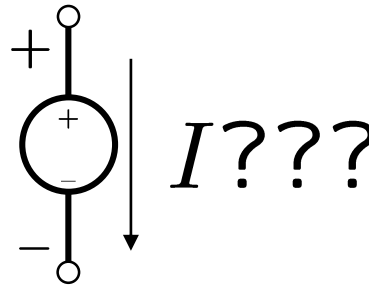

However, the value of the current is UNKNOWN and can only be determined through circuit analysis

IMPORTANT NOTE

For Example, here we only knew the voltage
before the analysis

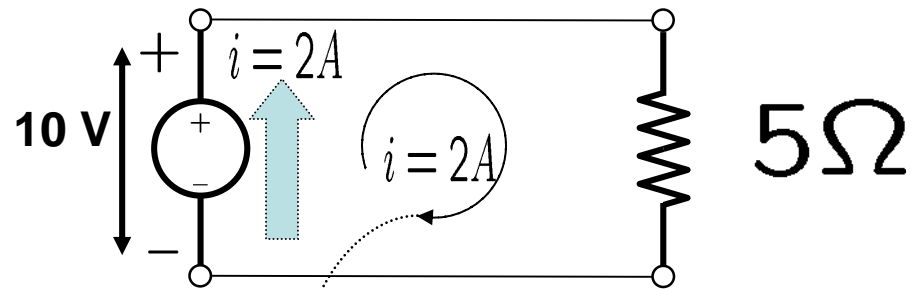

The current was determined later
from Ohm's law

IMPORTANT NOTE

In a current source, the current value through the element is KNOWN and is equal to the source value

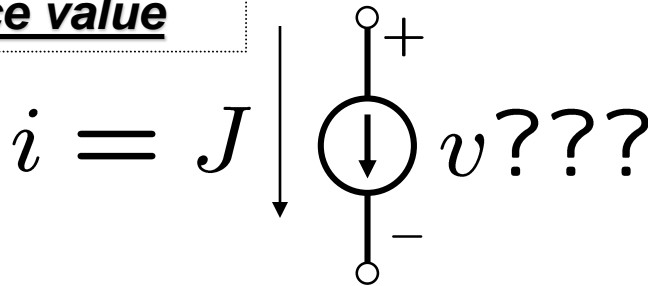

However, the value of the voltage is UNKNOWN and can only be determined through circuit analysis

IMPORTANT NOTE

For Example, here we only knew the current
BEFORE the analysis

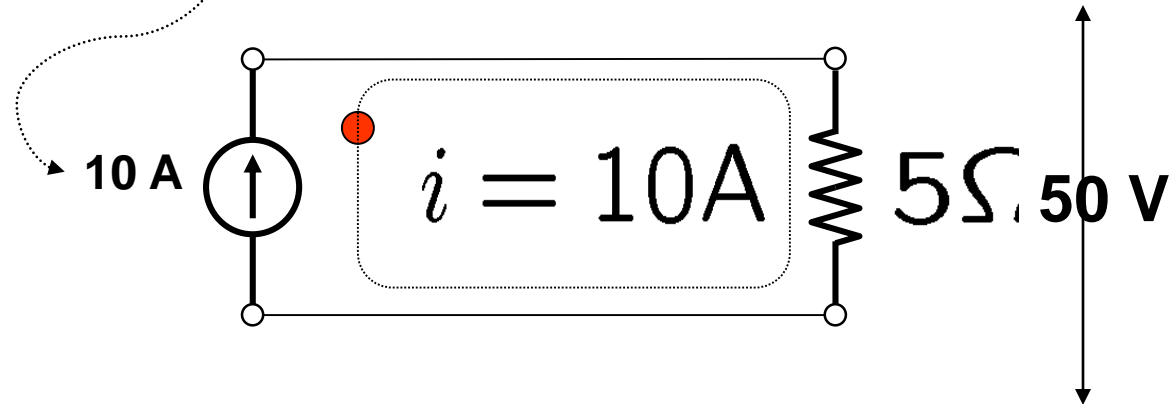

The voltage across the current source
could be determined only AFTER
using Ohm's law (analysis)

Resistive Circuits

**To deal with more general
circuits, we need
MORE THAN
Ohm's Law**

Resistive Circuits

To deal with more general circuits
We have to use

Kirchoff Current Law (KCL)

Kirchoff Voltage Law (KVL)

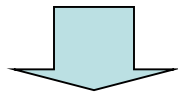

The algebraic sum of currents
at any node is always = 0

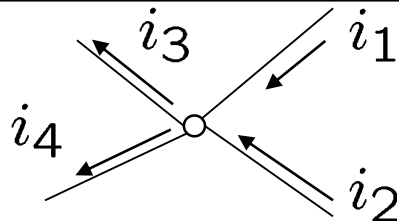

By convention, currents EXITING the
node are assigned PLUS sign, while
currents ENTERING the node
are assigned NEGATIVE sign, so

$$i_3 + i_4 - i_1 - i_2 = 0$$

Resistive Circuits

To deal with more general circuits
We have to use

Kirchoff Current Law (KCL)

The algebraic sum of currents
at any node is always = 0

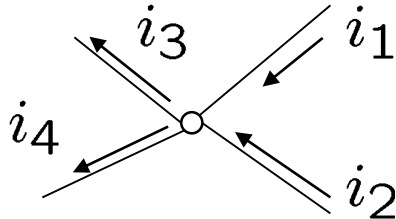

\sum Currents Entering the nodes

=

\sum Currents Exiting the nodes

$$i_1 + i_2 = i_3 + i_4$$

Kirchoff Voltage Law (KVL)

We need to understand
the concept of "LOOP"

A closed path through a
circuit that does not encounter
any intermediate loop more than
once.

We need examples

Resistive Circuits

The concept of Loops

Identify all the loops in the following circuits

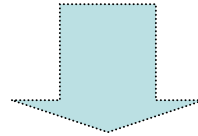
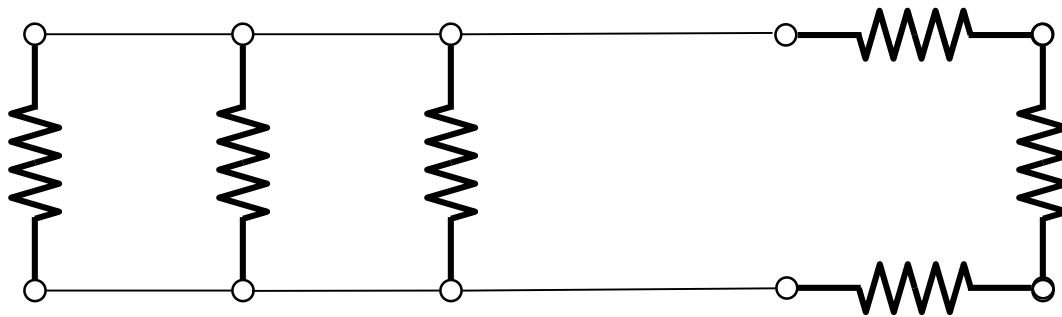

Determine all closed paths in the circuit

Resistive Circuits- *Loops*

Number of Loops = \rightarrow 6 Loops

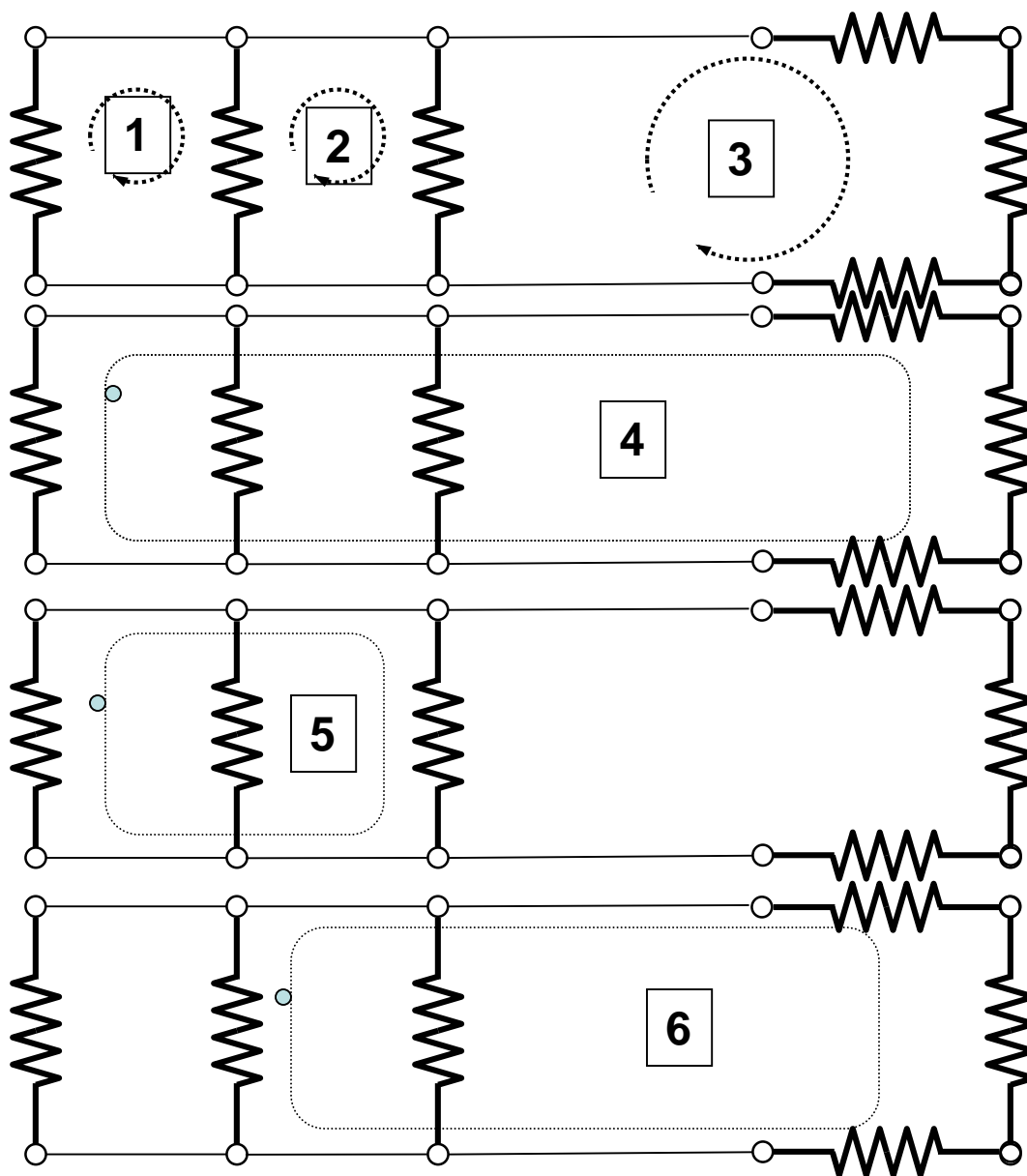

Resistive Circuits

How to deal with more general circuits?
We use

Kirchoff Current Law (KCL)

Kirchoff Voltage Law (KVL)

The algebraic sum of currents at any node is always = 0

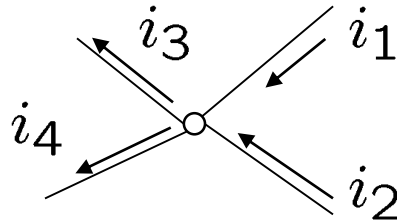

By convention, currents exiting the node are assigned plus sign, while currents entering the node are assigned negative sign, so

$$i_3 + i_4 - i_1 - i_2 = 0$$

The algebraic sum of voltages in a loop is always = 0

1. Move in a loop clockwise
2. If you encounter “+” sign of the voltage polarity, include it with a positive sign
3. If you encounter “-” sign of the voltage polarity, include it with a negative sign.

Example: Consider Loop 3 in the Previous example

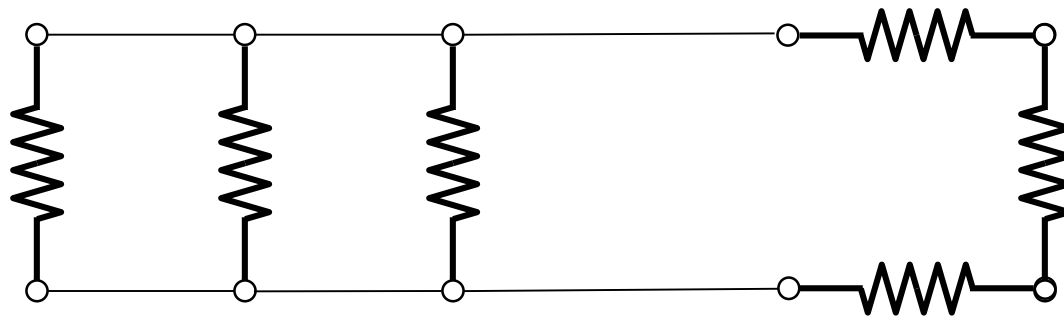

Assume Currents have been assigned as shown below

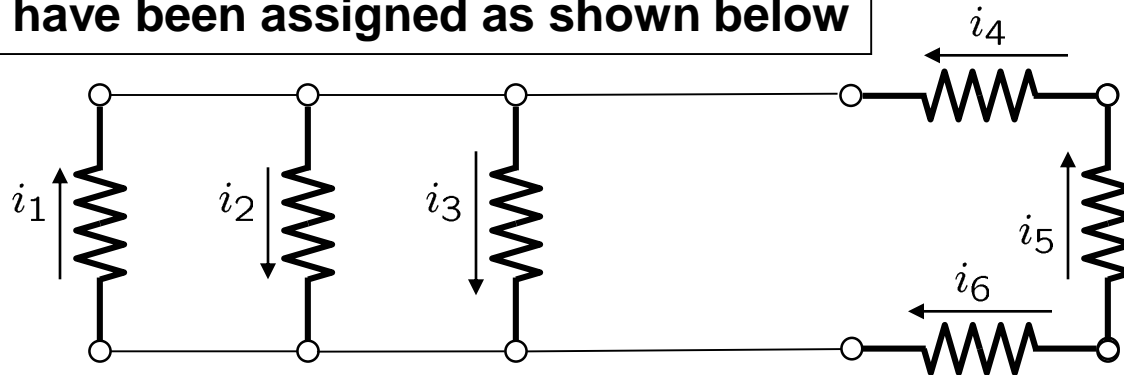

This means that the polarities of the voltages across the resistors will be given as shown below

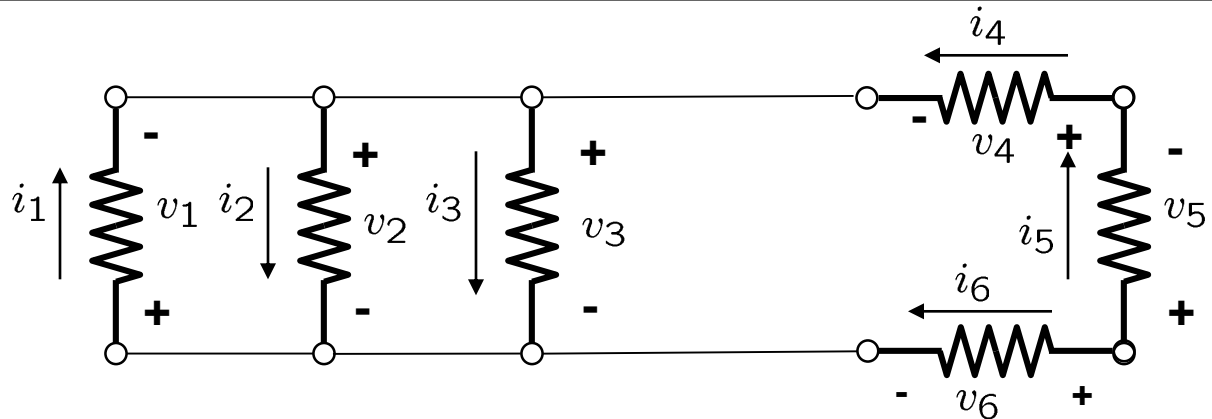

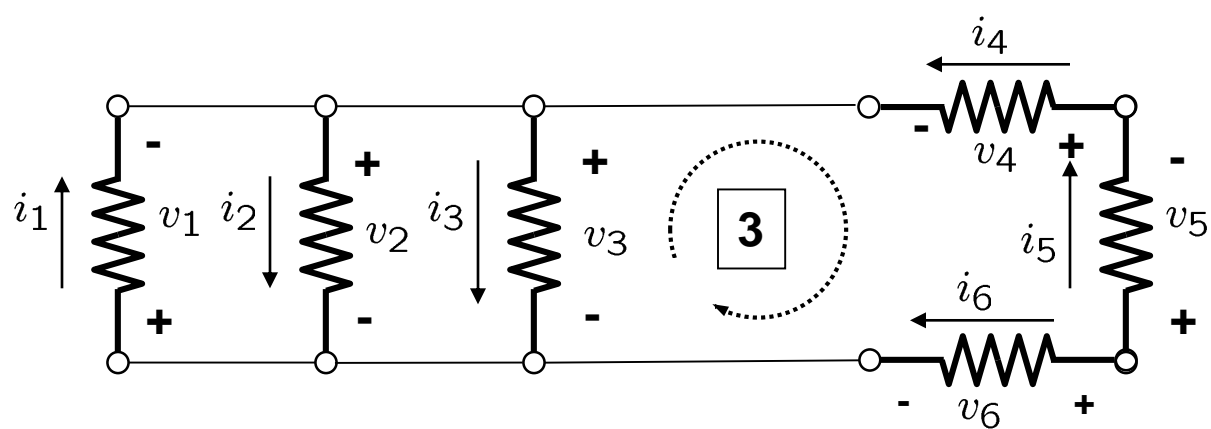

We now write KVL for loop 3.

As we move in the loop clockwise, we encounter

- $-v_3$
- $-v_4$
- $-v_5$
- $+v_6$

KVL for loop 3 is

$$-v_3 - v_4 - v_5 + v_6 = 0$$

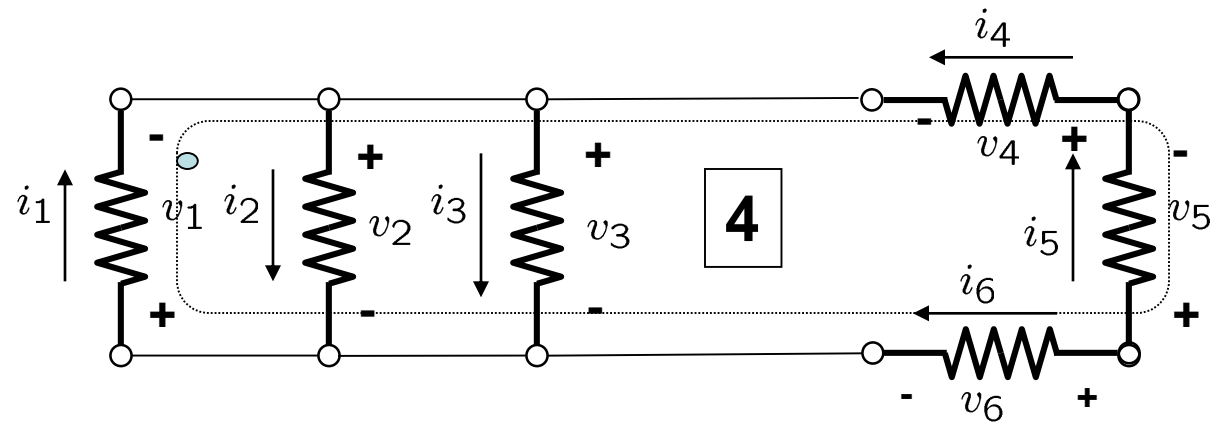

KVL for loop 4 is

$$v_1 - v_4 - v_5 + v_6 = 0$$

Resistive Circuits

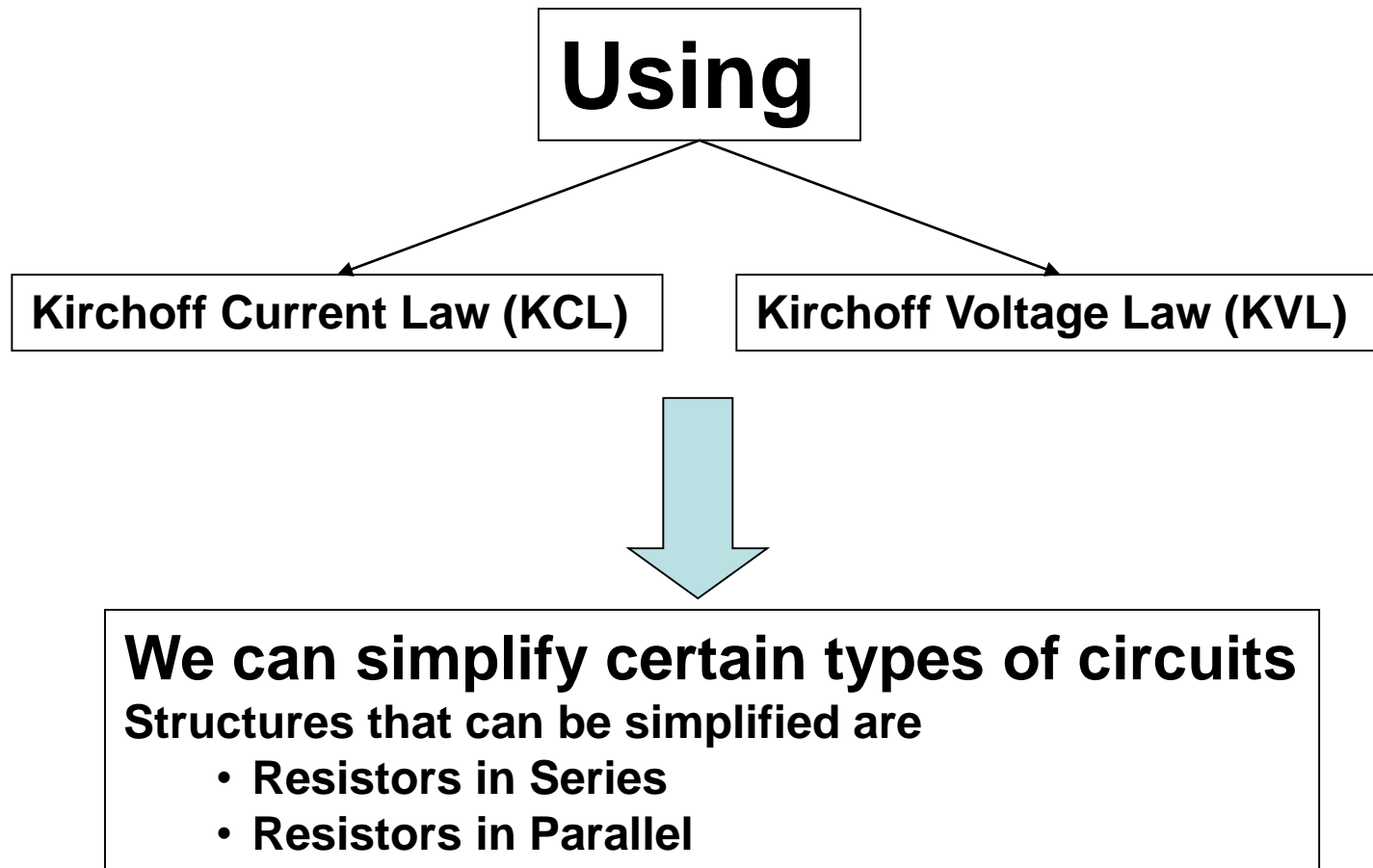

Resistive Circuits

Resistors in Series

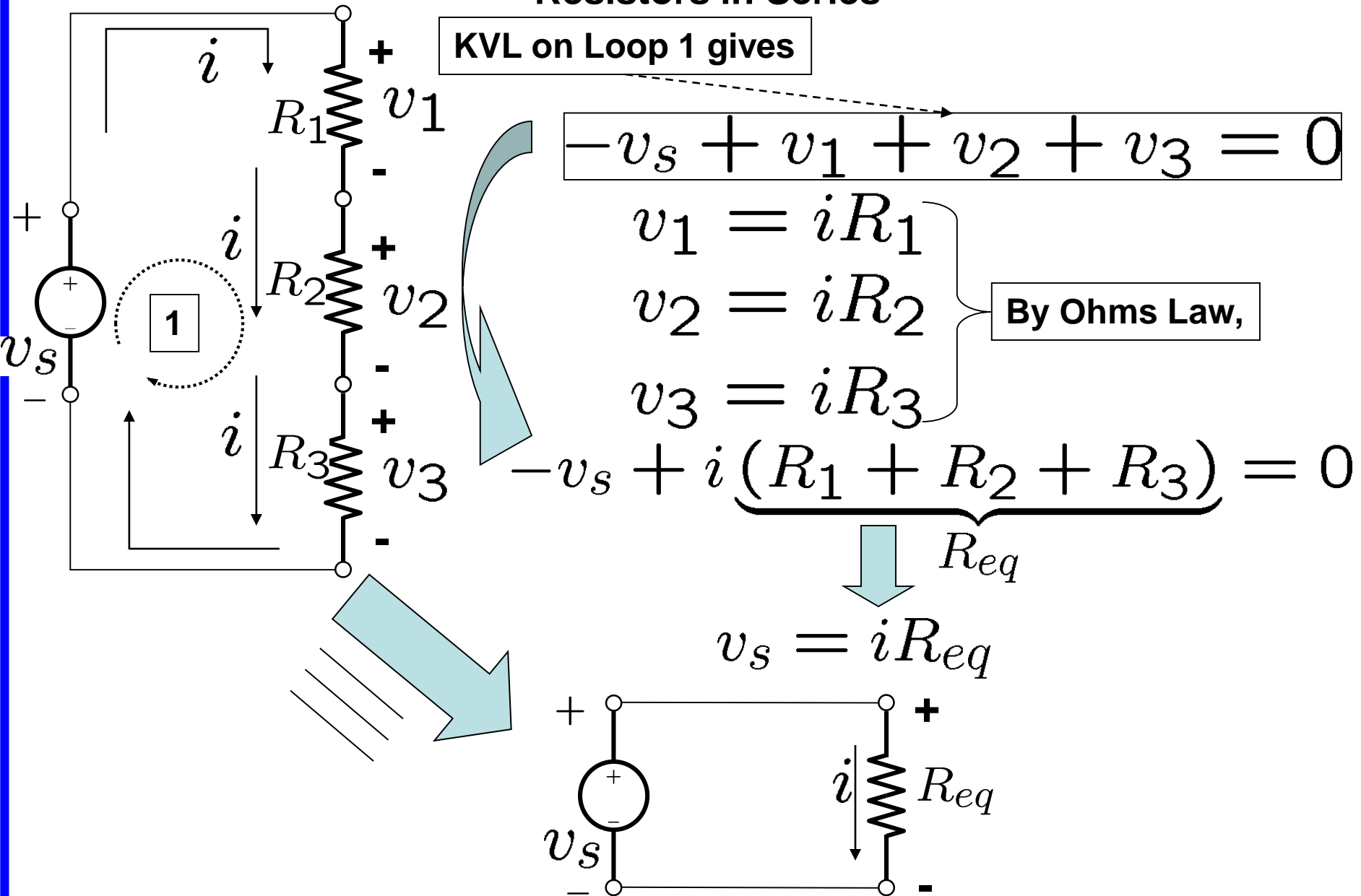

Resistive Circuits

Resistors in Series

The rule is that for resistors connected in series, one can replace them with a single resistor whose value is equal to their summation

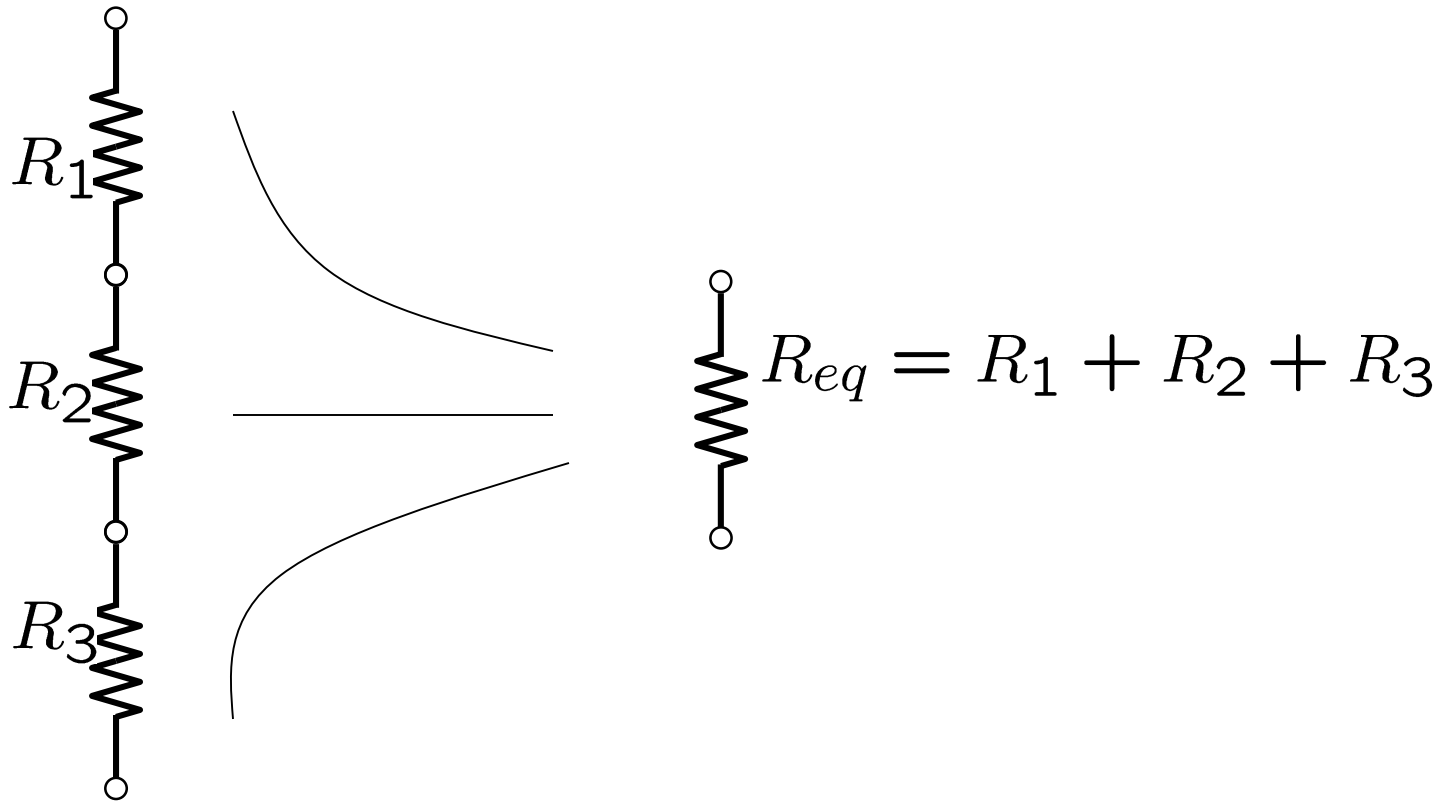

Resistive Circuits

Resistors in Series

Example: Draw an equivalent circuit. Use the equivalent circuit to find the current i

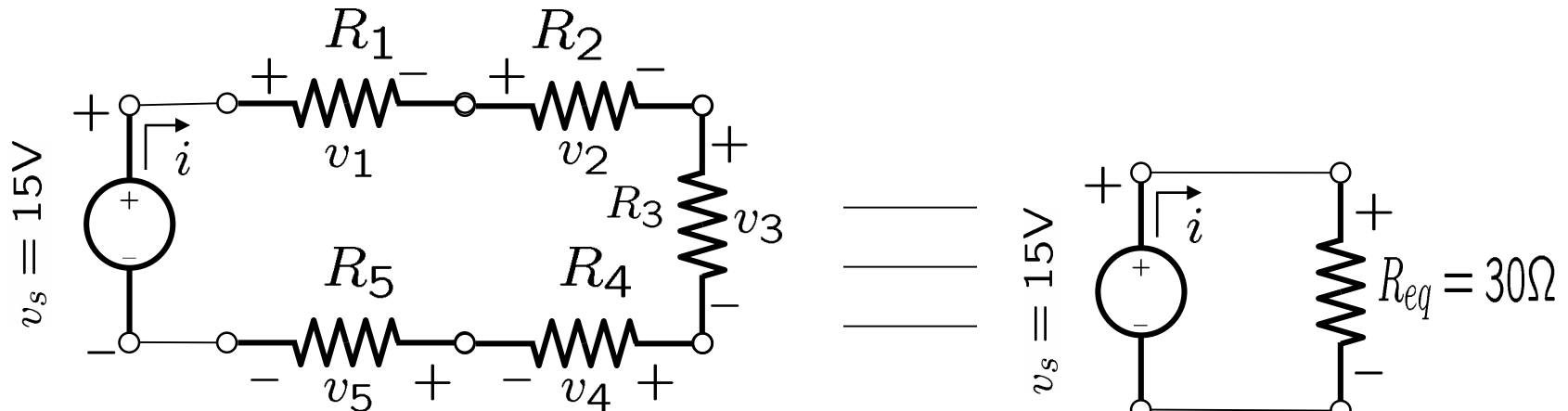

$$R_1 = 2\Omega$$

$$R_2 = 4\Omega$$

$$R_3 = 6\Omega$$

$$R_4 = 8\Omega$$

$$R_5 = 10\Omega$$

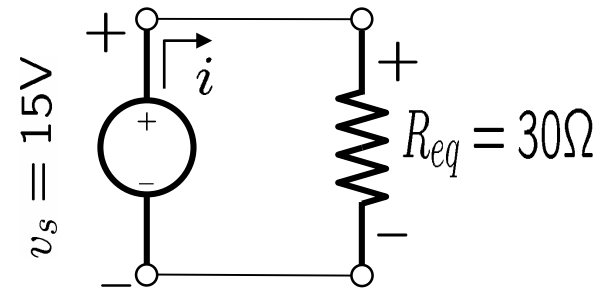

$$i = \frac{v_s}{R_{eq}} = \frac{15}{30} = 0.5\text{A}$$

Resistive Circuits

Resistors in Parallel

We need an equivalent resistor R_{eq} that can replace R_1 , R_2 and R_3 .

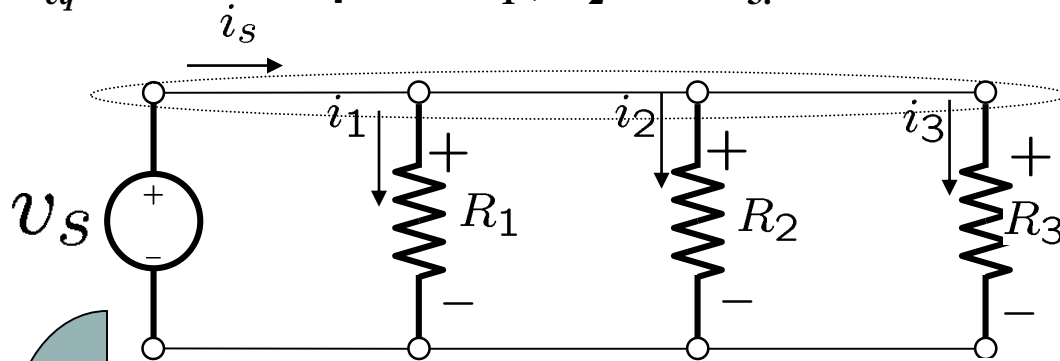

Single Node
Call it Node (a)

Applying KCL on Node (a) gives

$$-i_s + i_1 + i_2 + i_3 = 0$$

$$i_s = i_1 + i_2 + i_3$$

We must also have, $i_{eq} = i_s$

$$\text{Hence, } i_{eq} = i_1 + i_2 + i_3$$

$$\text{From Ohm's law, } v_s = i_{eq} R_{eq}$$

$$R_{eq} = \frac{v_s}{i_{eq}}$$

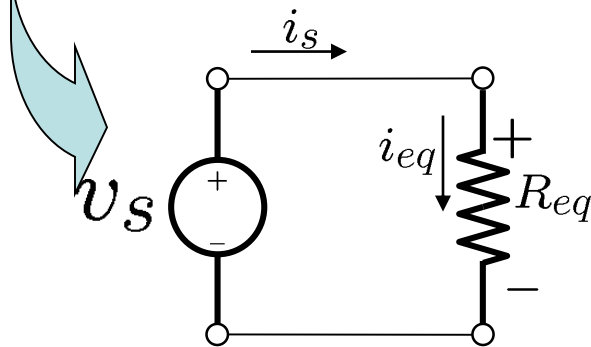

Resistive Circuits

Resistors in Parallel

The rule is that for resistors connected in parallel, one can replace them with a single resistor whose value is equal to the reciprocal of summation of their reciprocals.

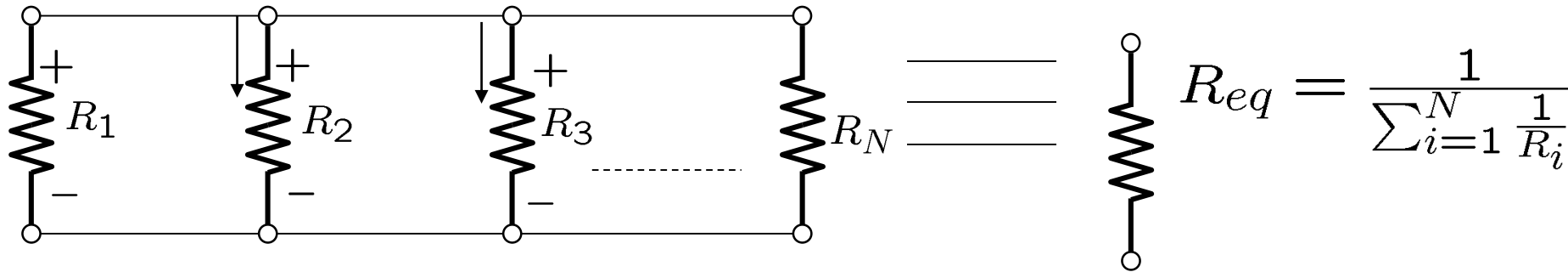

It is typically easier to remember the above rule in terms of conductance rather than resistor. A conductance is the reciprocal of a resistor, i.e., the conductance of a resistor R_1 is $(1/R_1)$. Representing the above their resistors by their conductance gives the following circuit

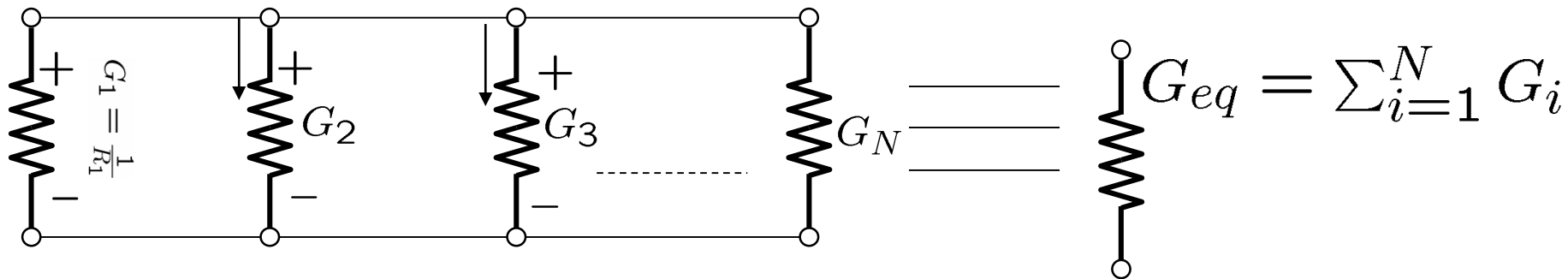

Resistive Circuits

Resistors in Parallel

It is typically easier to remember the above rule in terms of conductance rather than resistance.

A conductance is the reciprocal of a resistance, i.e., the conductance of a resistor R_1 is $(1/R_1)$. Representing the resistors of the previous circuit by their conductances gives the following circuit.

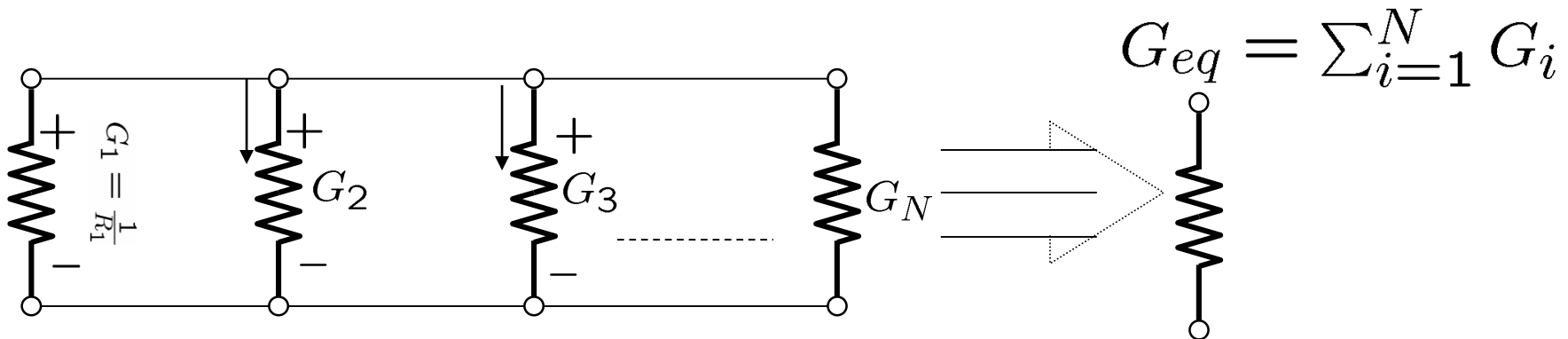

Resistive Circuits

An Example

For the circuit shown below, draw a simplified equivalent circuit.
Use the equivalent circuit to calculate the current i_s flowing in the source.

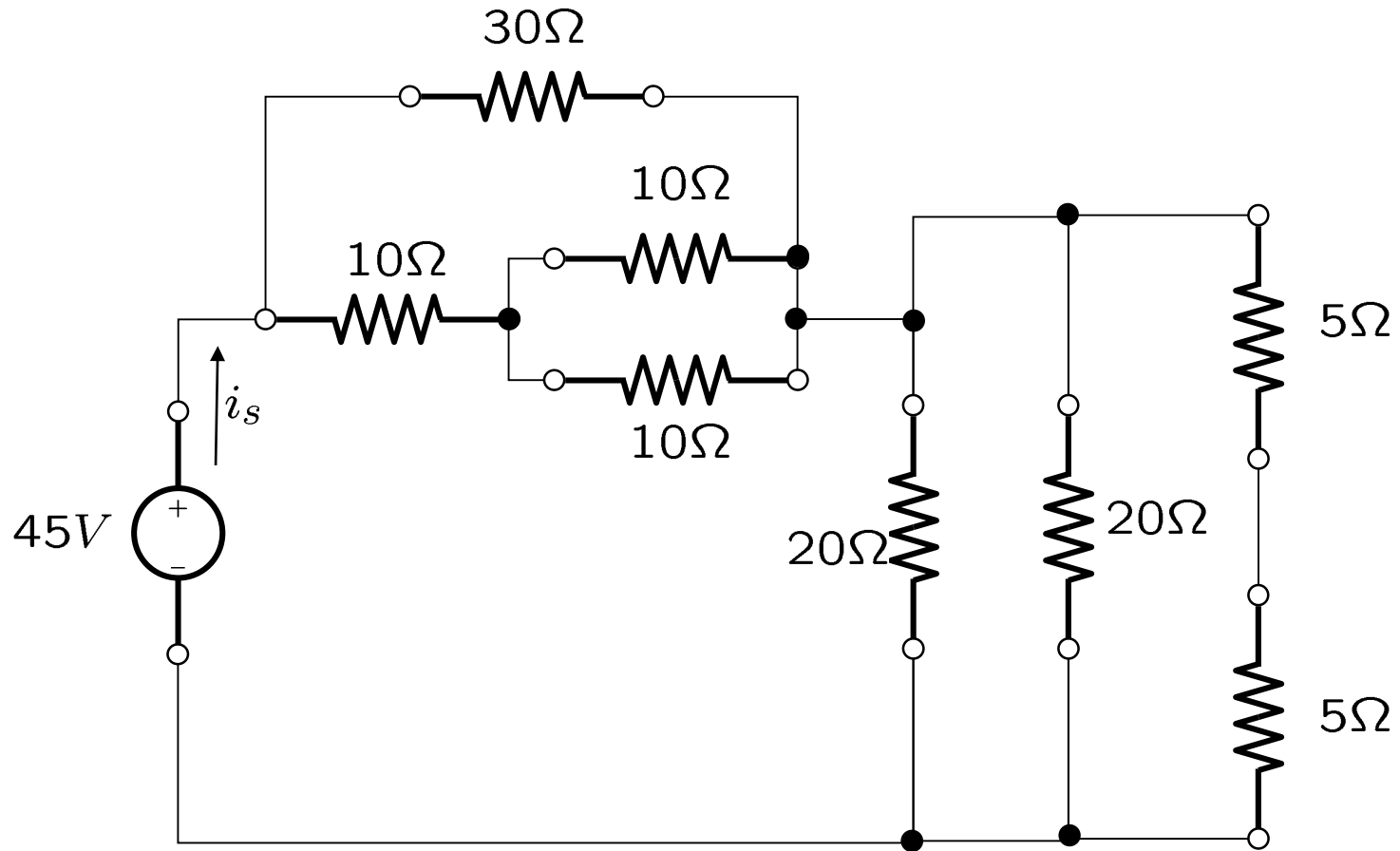

Resistive Circuits

An Example

Solution

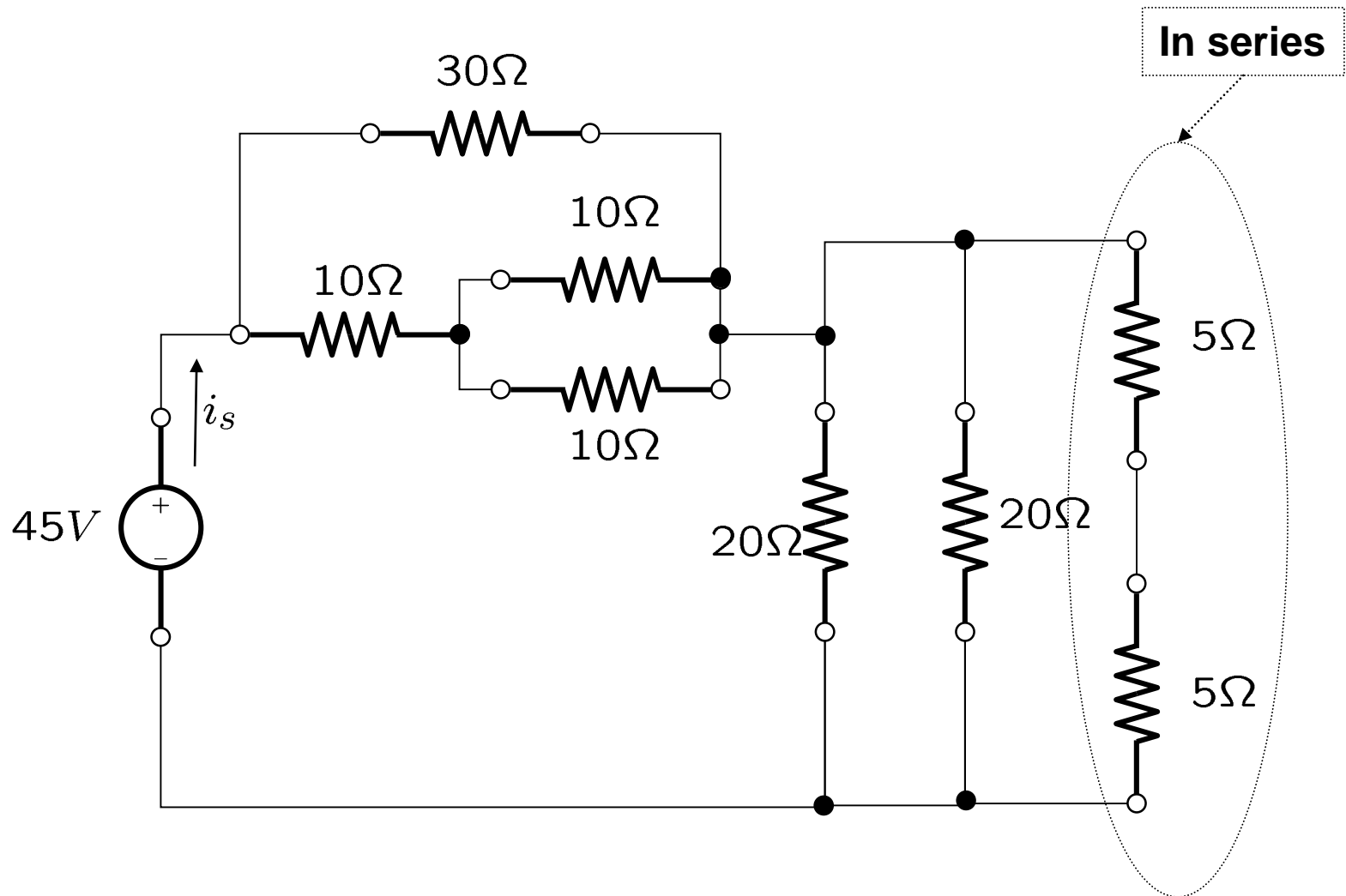

Resistive Circuits

An Example

Solution

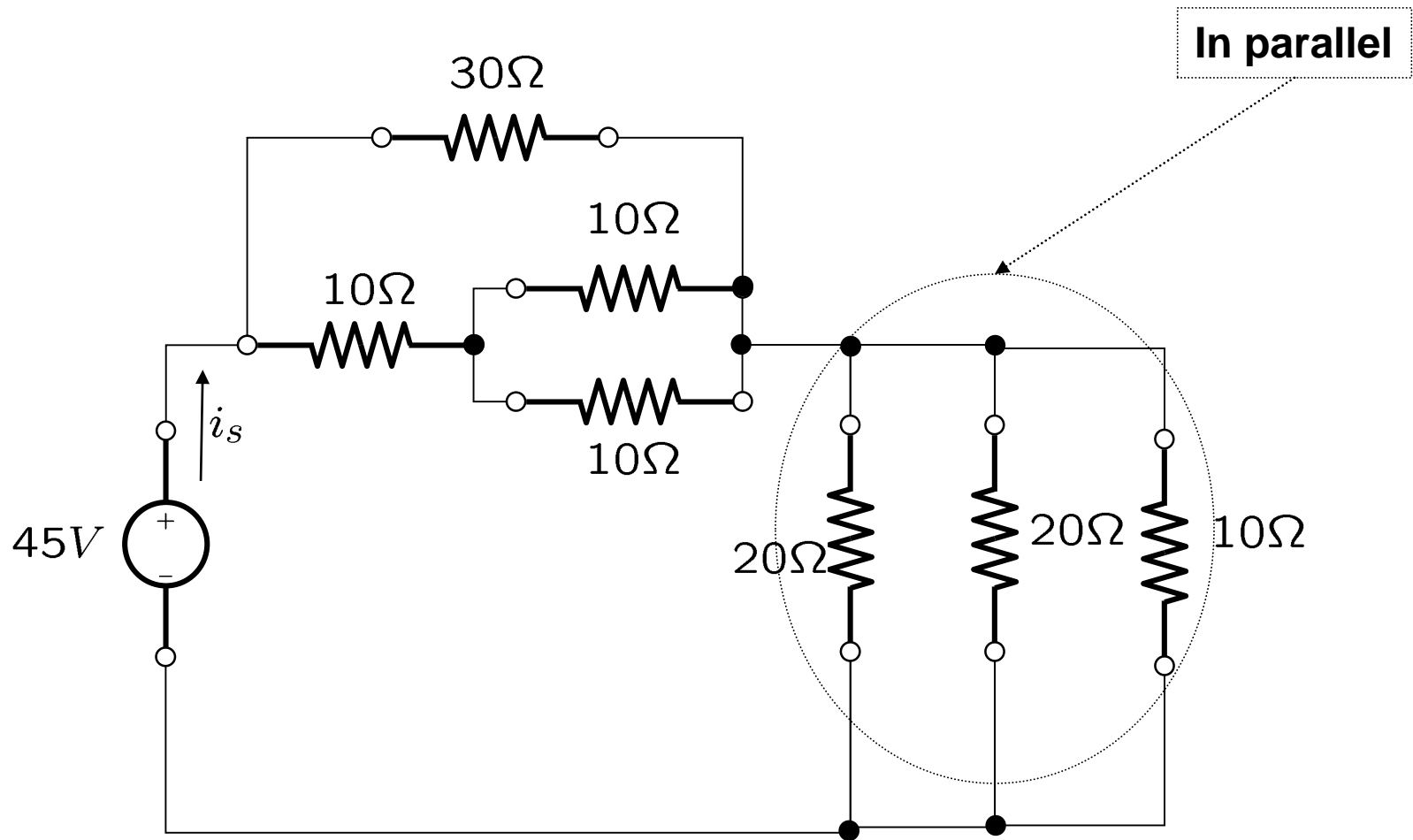

Resistive Circuits

An Example

Solution

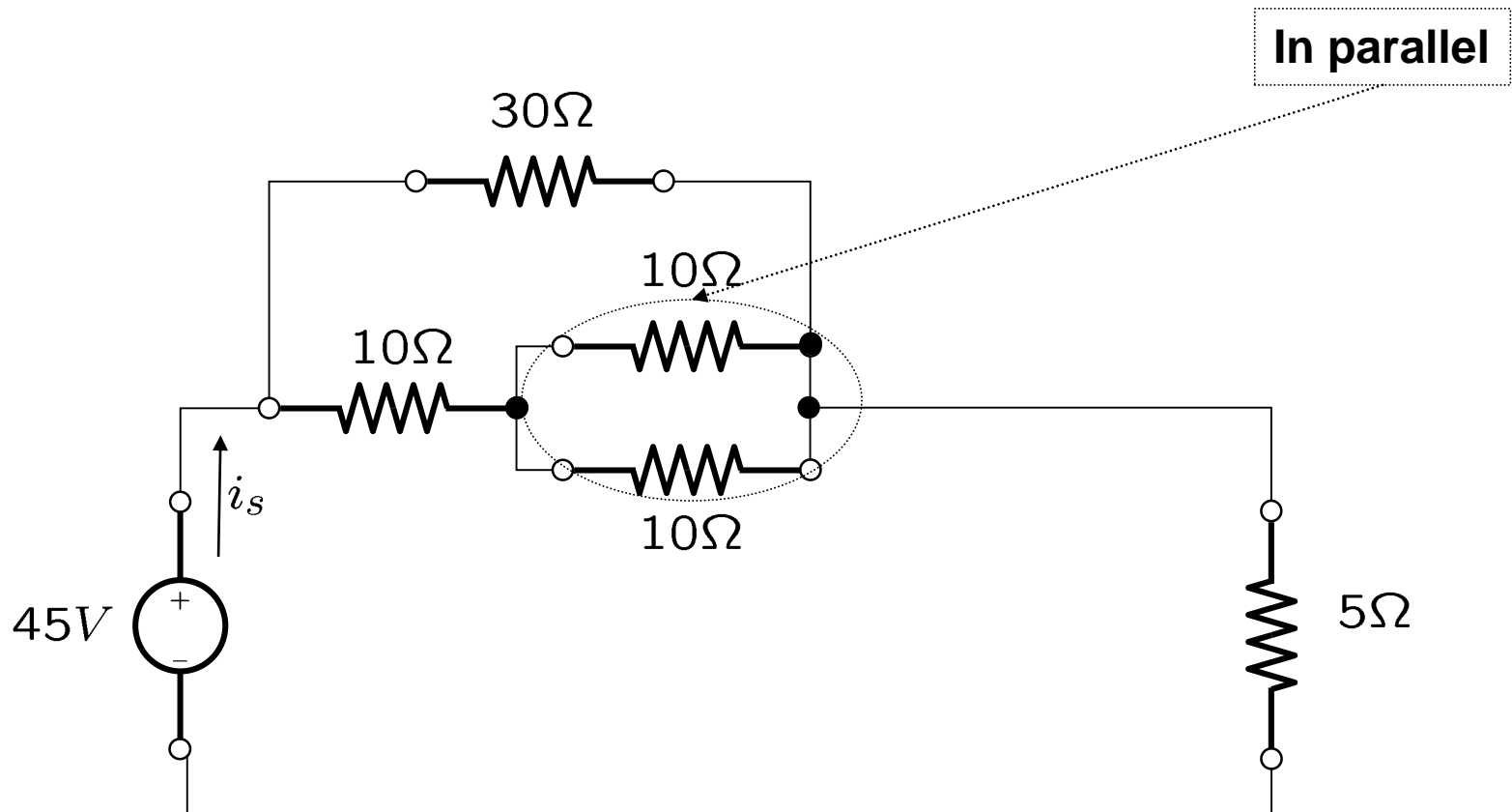

Resistive Circuits

An Example

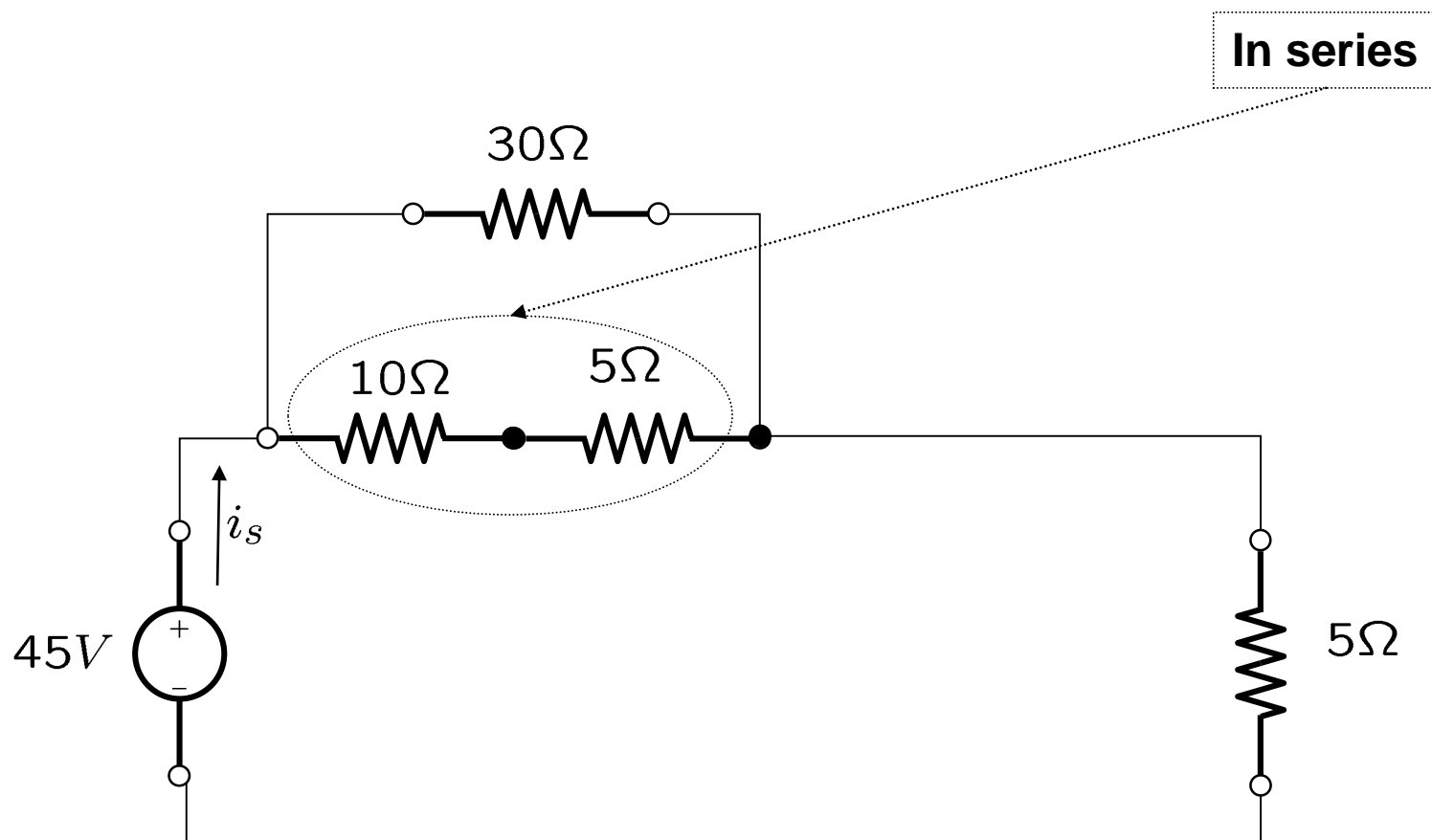

Resistive Circuits

An Example

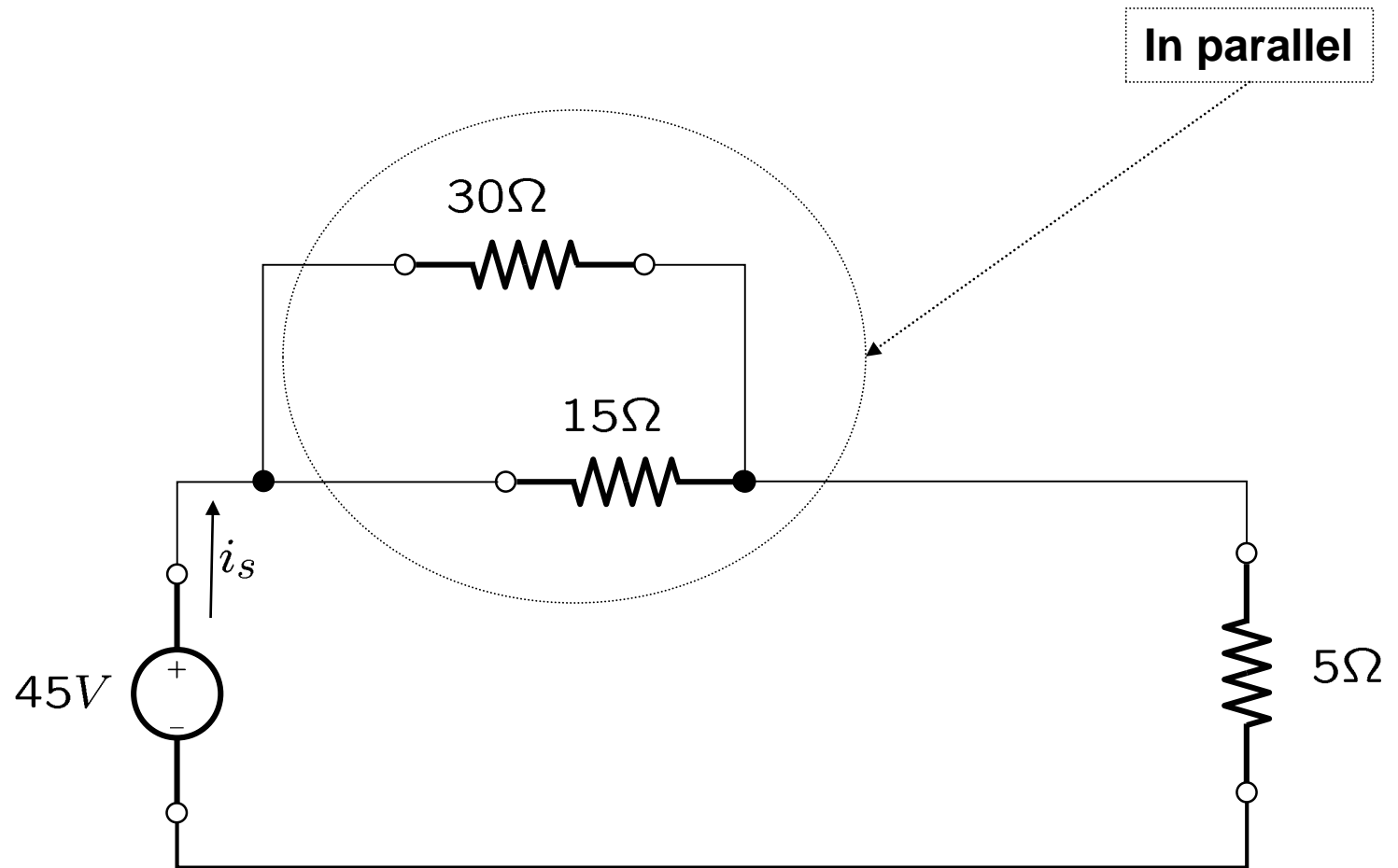

Resistive Circuits

An Example

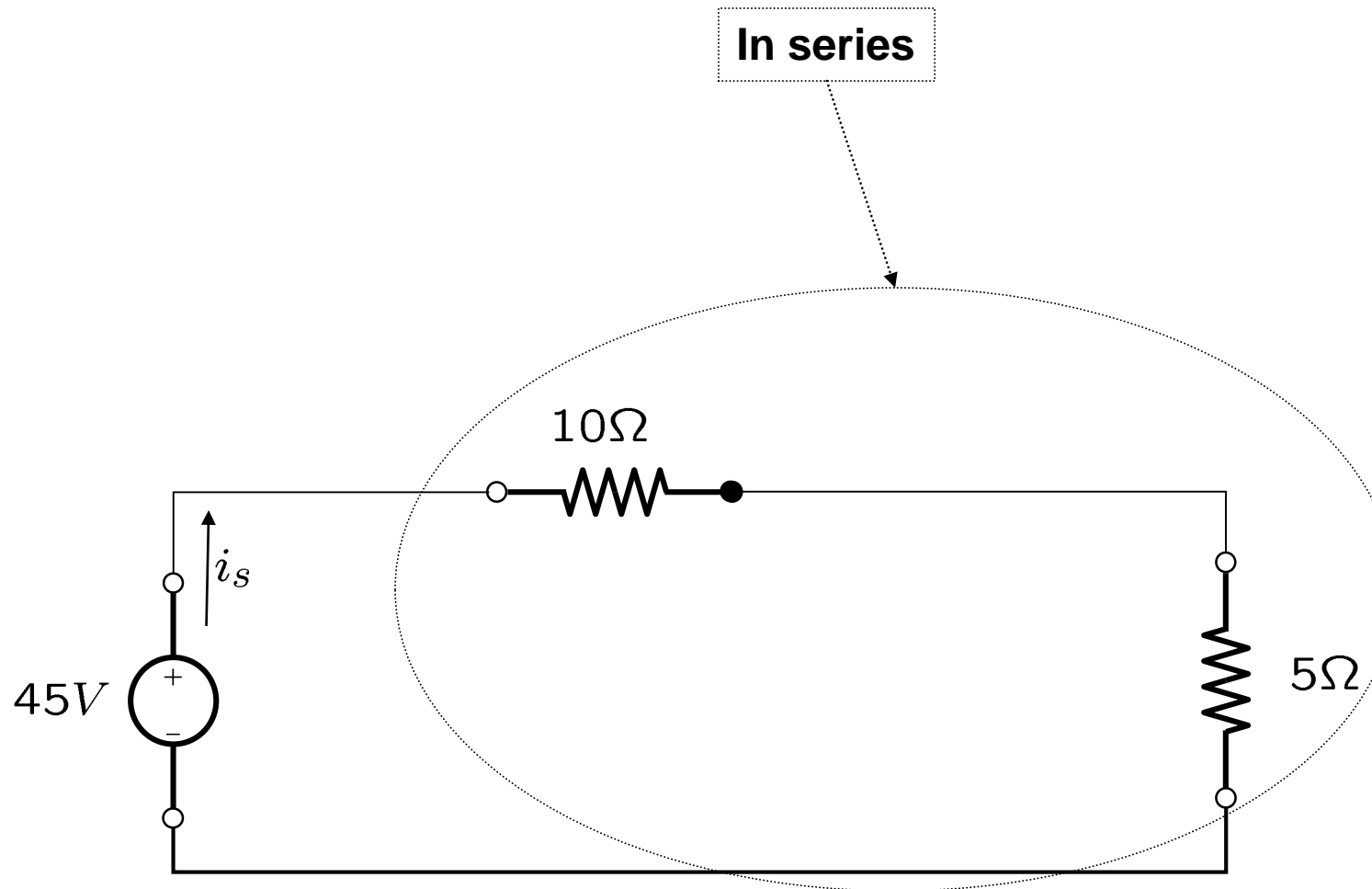

Resistive Circuits

An Example

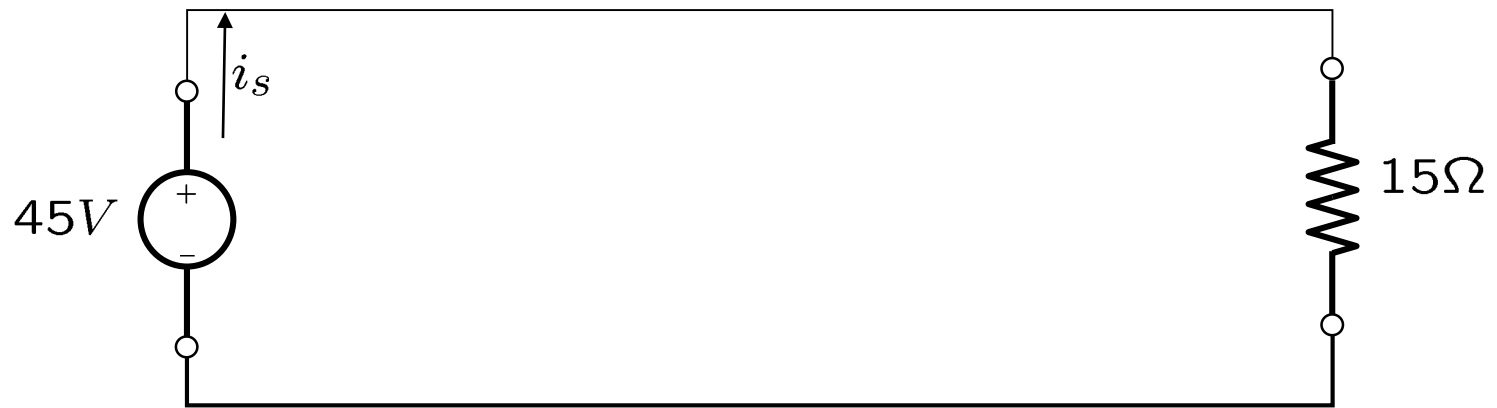

$$i_s = \frac{45}{15} = 3\text{A}$$