

# ELG2130 A

Prepared by Dr.  
Emad Gad

# Module 1

*Electric Circuit Variables*

# Brief History of Major Electrical Concepts

**Phenomenon  
(Electric)**

Lightening  
Rubbing a piece of glass → →  
picks small paper or grass

**When quantified**

**Charge  
(Coulombs)**

**Work required to  
move charge**

**If charge flows**

**Voltage  
(Volt)**

**Current  
(Ampere)**

**Power  
(Watt)**

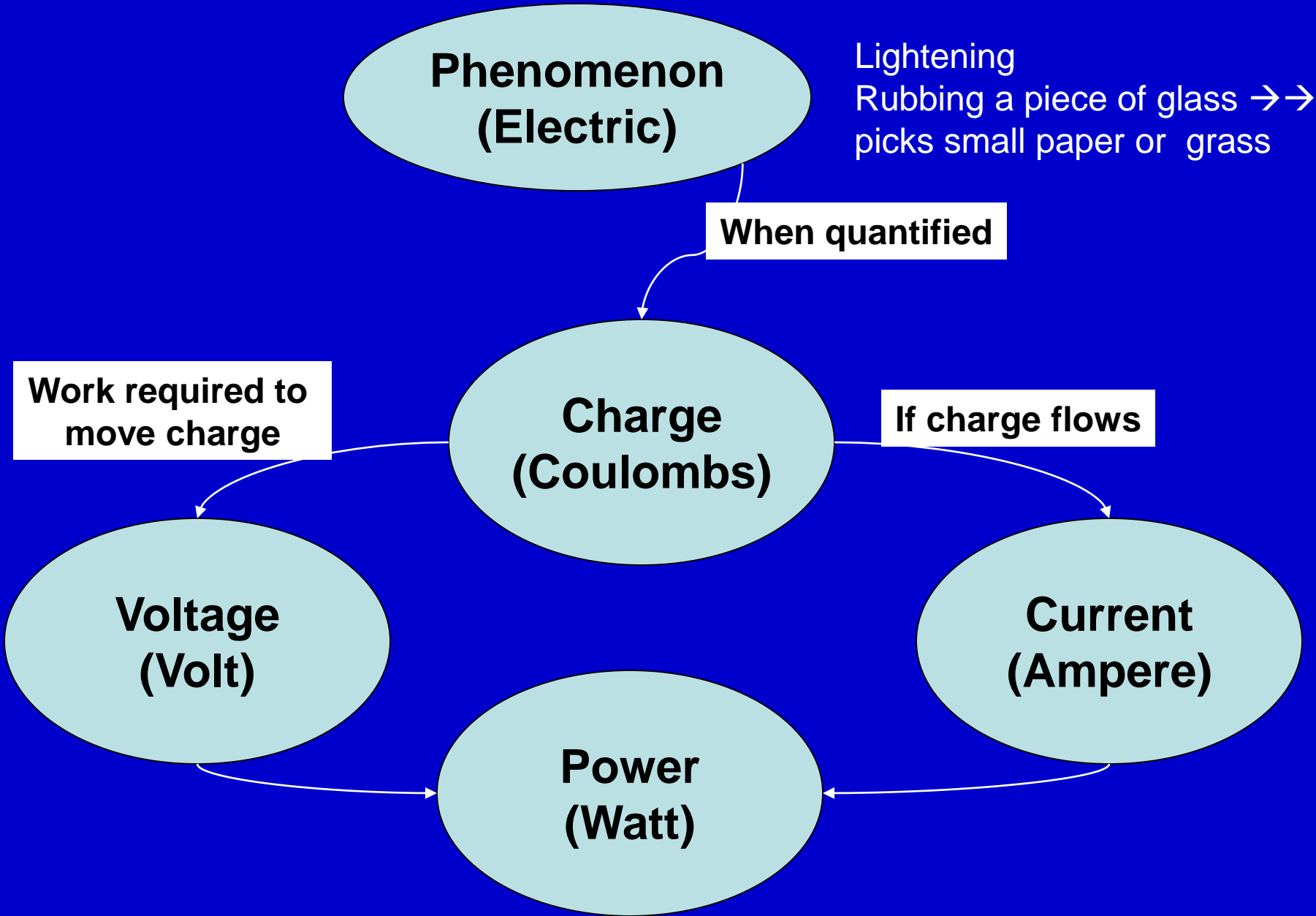

**Phenomenon  
(Electric)**

*needs to be quantified,  
or assigned a numerical value*

**Examples**

- Lightening
- Rubbing a piece of glass → → picks small paper or grass

**Charge  
In Coulombs**

Large Charge is observed

means

Stronger Phenomenon is occurring

means

**Measured in Units of Coulombs  
( C )**

- 1 C = the charge of  $6.24 \cdot 10^{18}$  electrons put together

About 6 million trillion (or quintillion)

# Brief History of Major Electrical Concepts

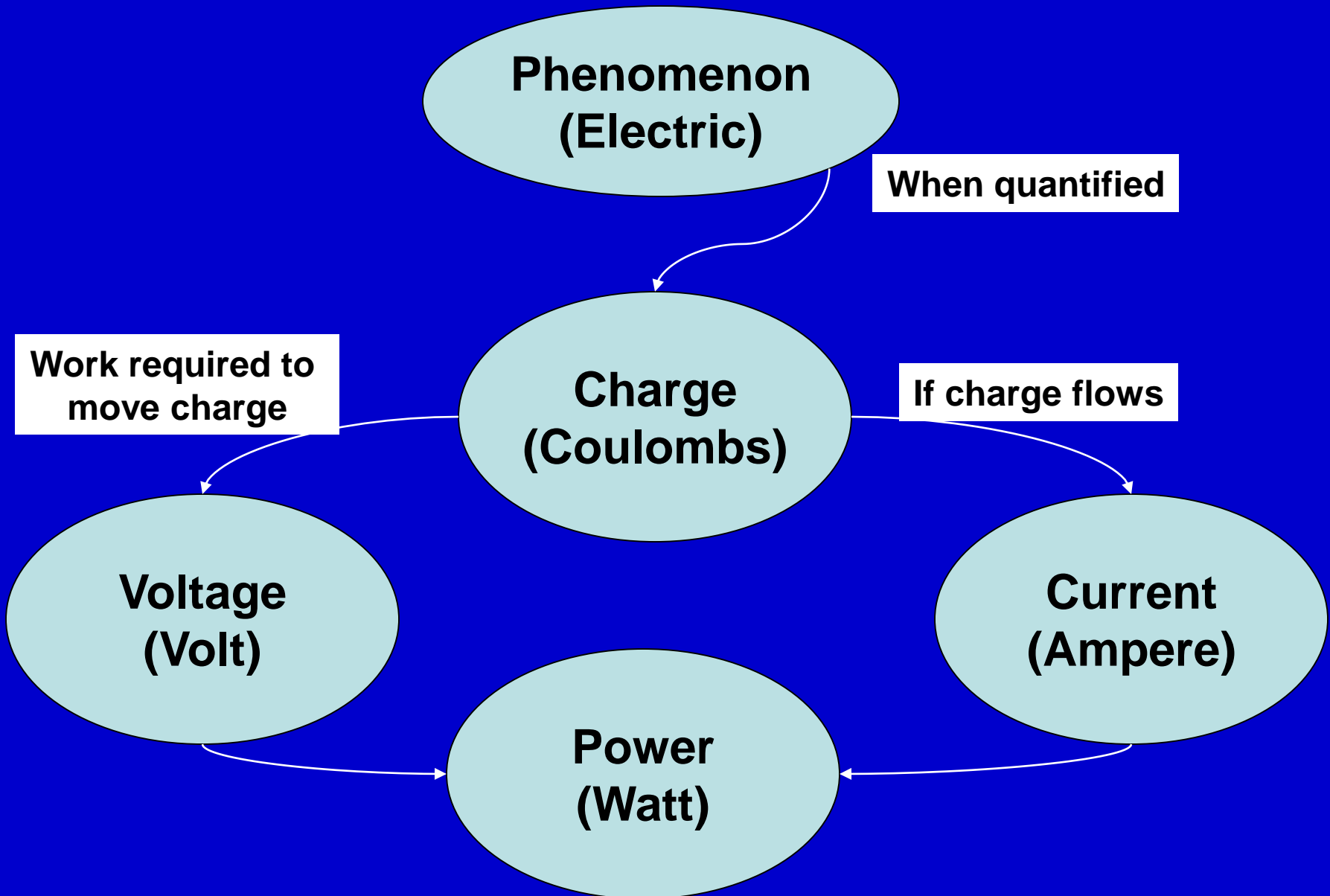

**Charge  
In Coulombs**

Flow of charge

When charge flows  
it generates

**Current**

**Direction**

Is the same as the Direction of flow of positive charge

**Value**

•Rate of change of Charge  
(Coulombs/Sec) → Ampere (A)

$$i = \frac{\Delta q}{\Delta t}$$

$$i = \frac{dq}{dt}$$

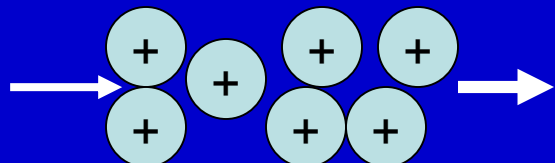

Opposite direction of flow  
of negative charge

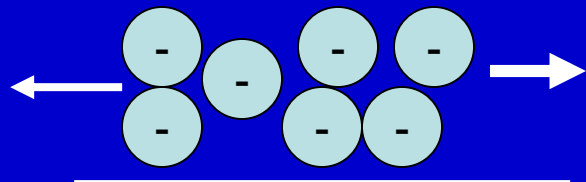

# Brief History of Major Electrical Concepts

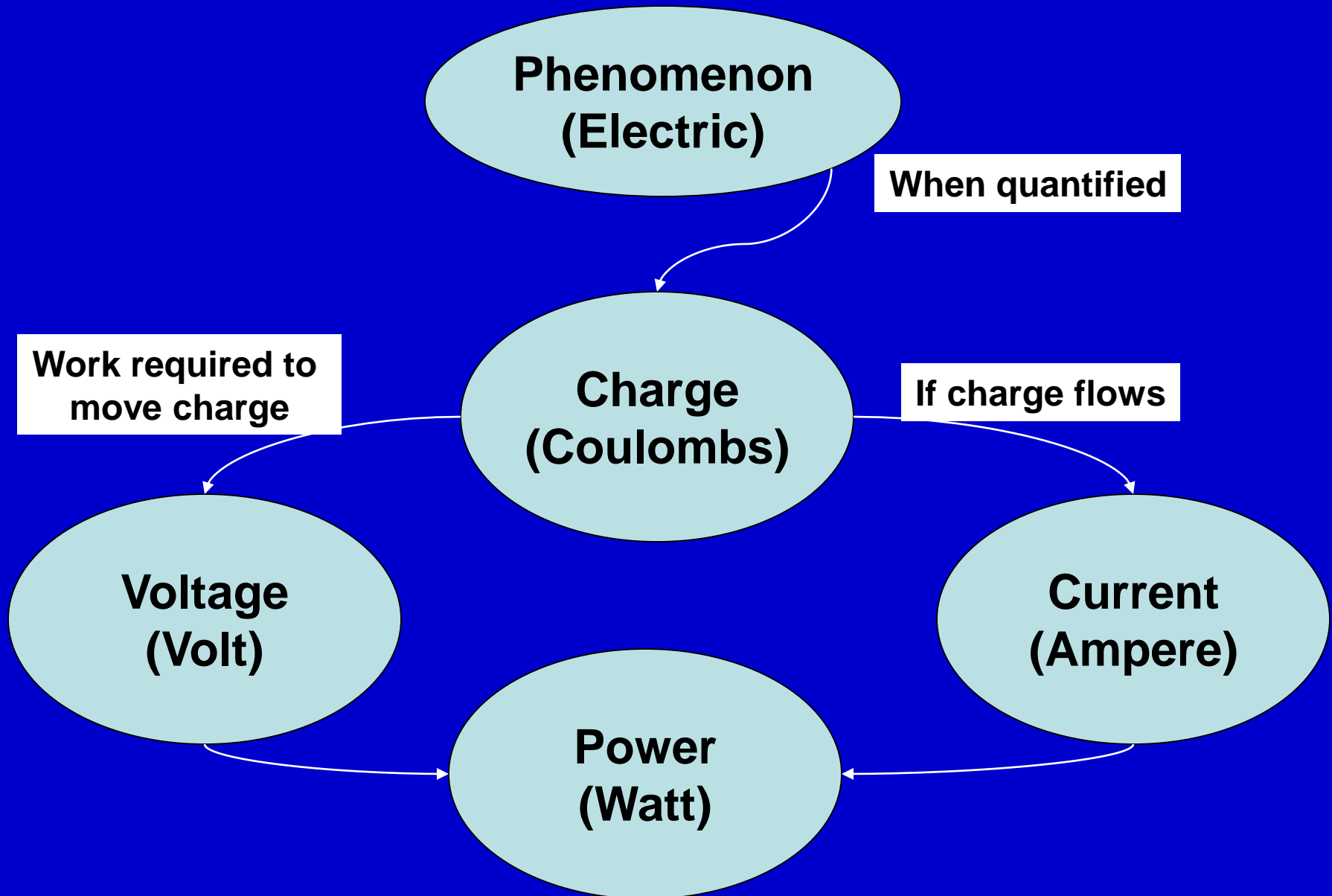

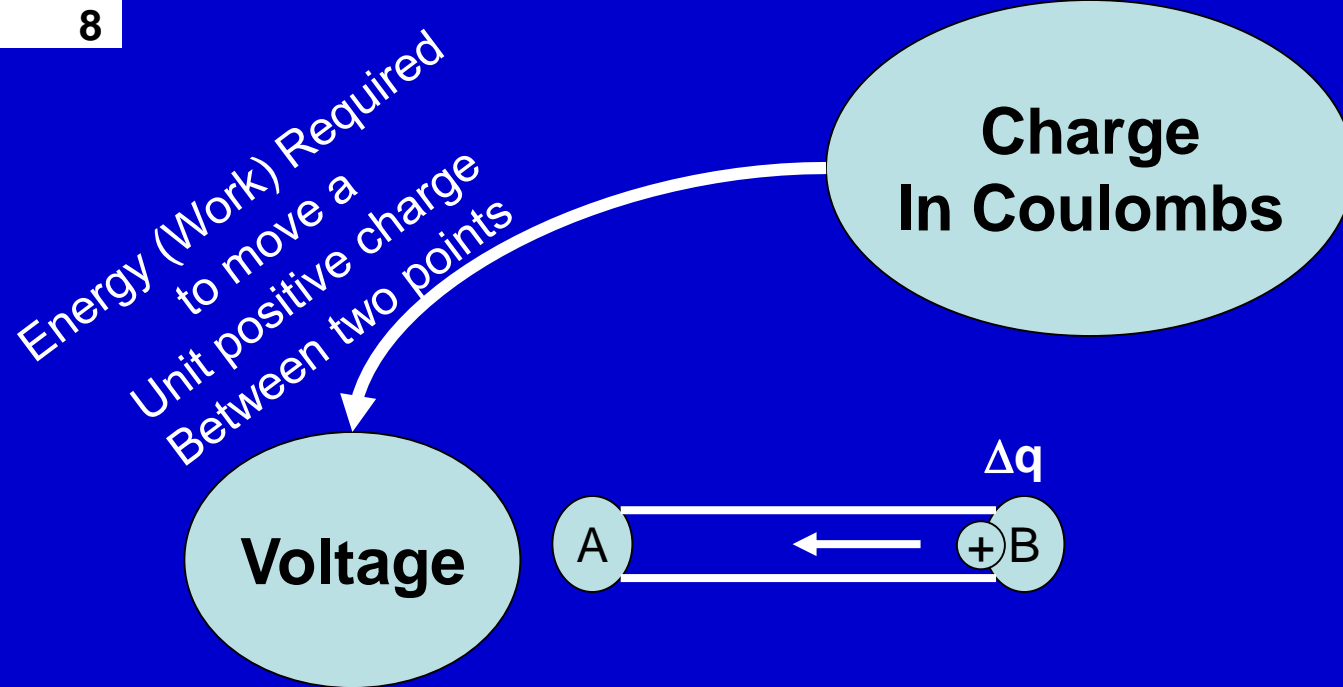

As an example: If it takes energy of ( $\Delta w$ ) in Joules (units of energy) to move a charge ( $\Delta q$ ) in Coulombs, from point B to point A then we say that

$$v_{AB} = \frac{\Delta w}{\Delta q} \rightarrow \frac{dw}{dq} \text{ in Volts}$$

**Note that**  $v_{AB} = -v_{BA}$

In other words, the energy required to move a unit positive charge from B to A is the negative energy required to move a unit positive charge from A to B!!

**Why? → Use the following analogy**

# Analogy

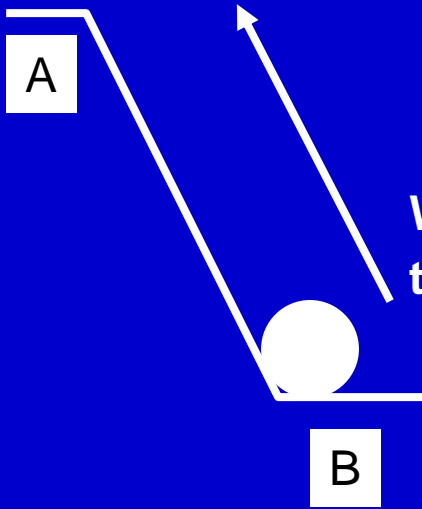

We **NEED** to exert energy (say X Joule units) to get the stone from B to A

We **Get Back** energy (X Joule units) to get the stone from A to B. For example this stone can move another stone from B to C when it gets to B. This is why we say that the energy required to move the stone from A to B is  $-X$ , i.e., an energy gained back rather than exerted.

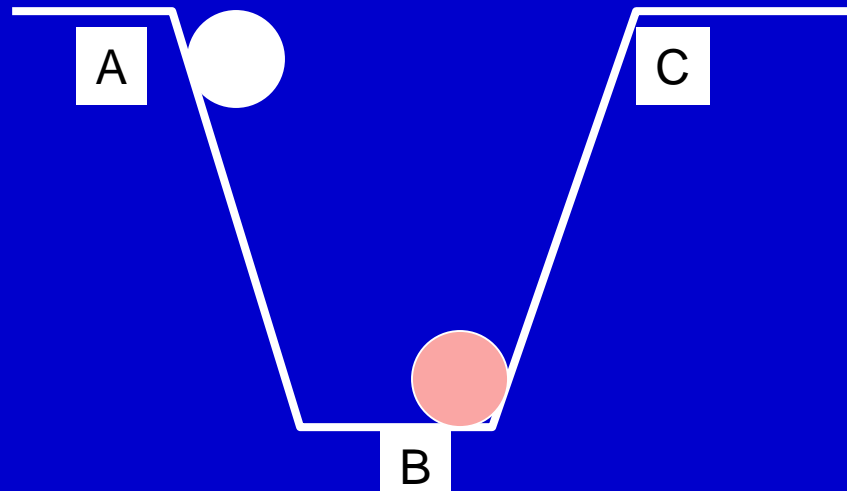
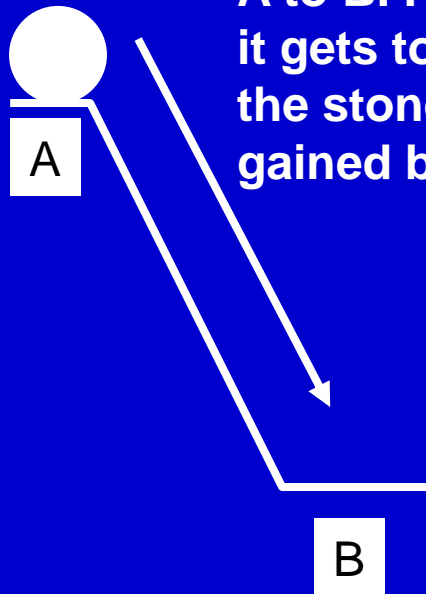

**Charge  
In Coulombs**

**Energy (Work) Required  
to move a  
Unit positive charge  
Between two points**

**Voltage  
Electrical Potential**

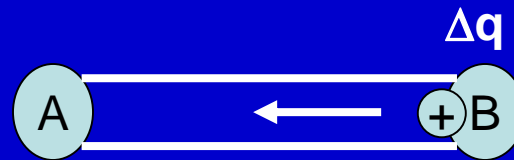

$$v_{AB} = -v_{BA}$$

# Brief History of Major Electrical Concepts

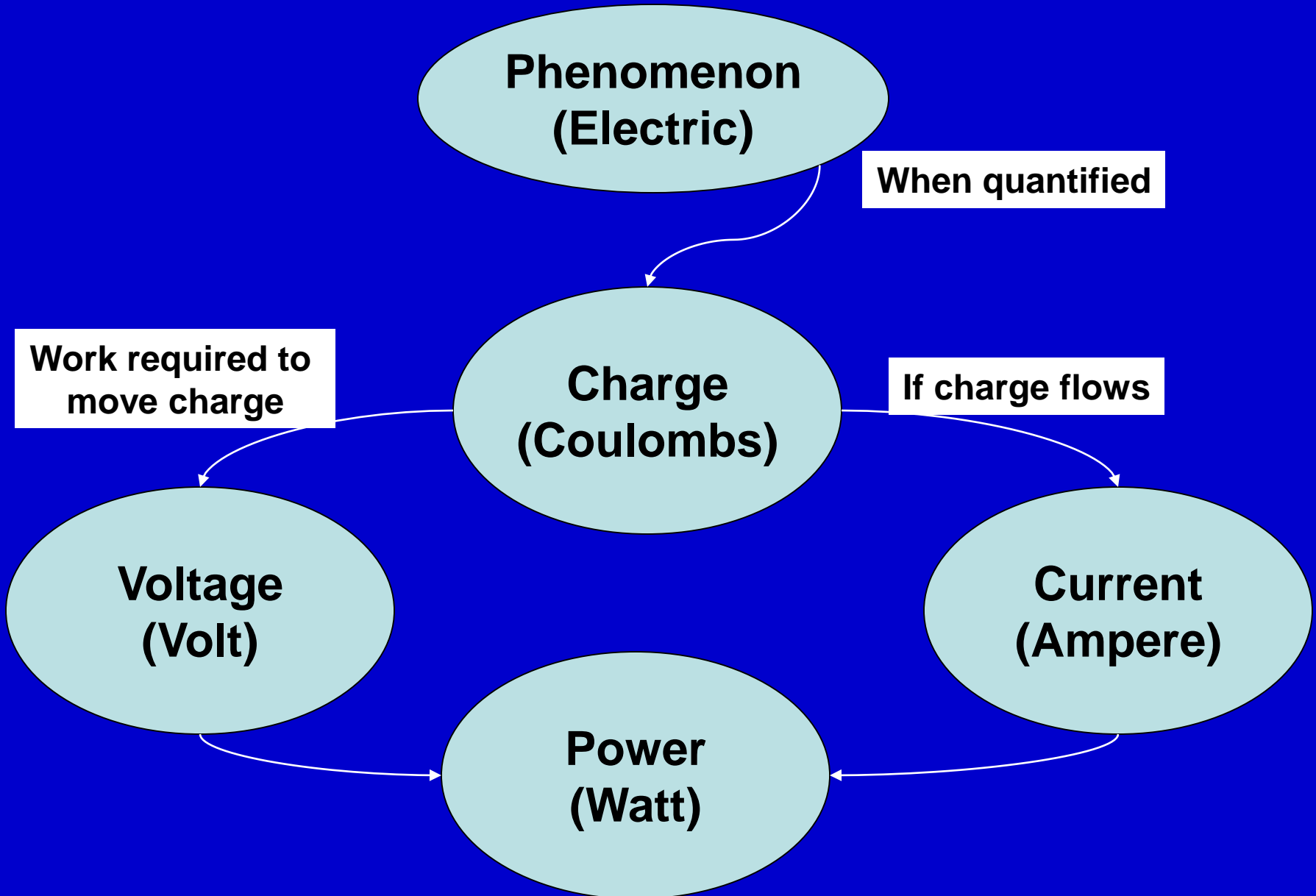

# What is POWER?

- It is the rate at which a human or a machine takes or gives energy (work)

$$p = \frac{d \text{work}}{dt}$$

- In case of a piece of a material that has voltage  $v$  and current  $i$  resulting from flow of charge  $q$ , Is it possible to compute the power supplied/received by such a piece of material??

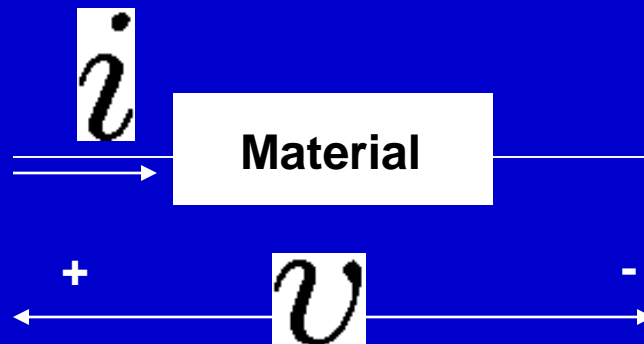

# What is POWER?

$$p = \frac{d \text{work}}{dt} = \frac{dw}{dq} \frac{dq}{dt} = vi$$

The Units of power is Joules/Sec is called the watt.

# Independent Sources Of Electricity

These are sources that generate power in the circuit and they come in two basic sources

Independent  
**Current** Sources

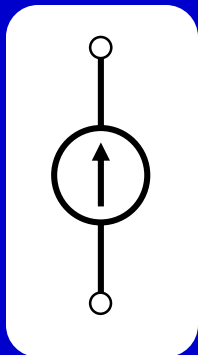

Independent  
**Voltage** Sources

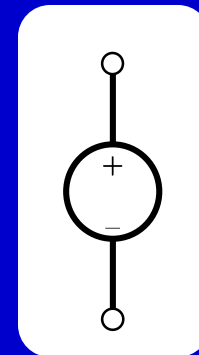

# What is voltage source?

It is a device (e.g. battery) that guarantees that its terminals are different in potential with a prescribed value.

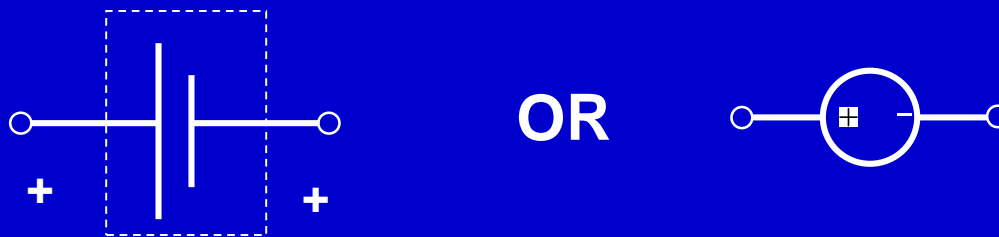

Energy storage element that generates voltage between its terminals

# Voltage Sources

Energy storage elements that generate voltage between it terminals

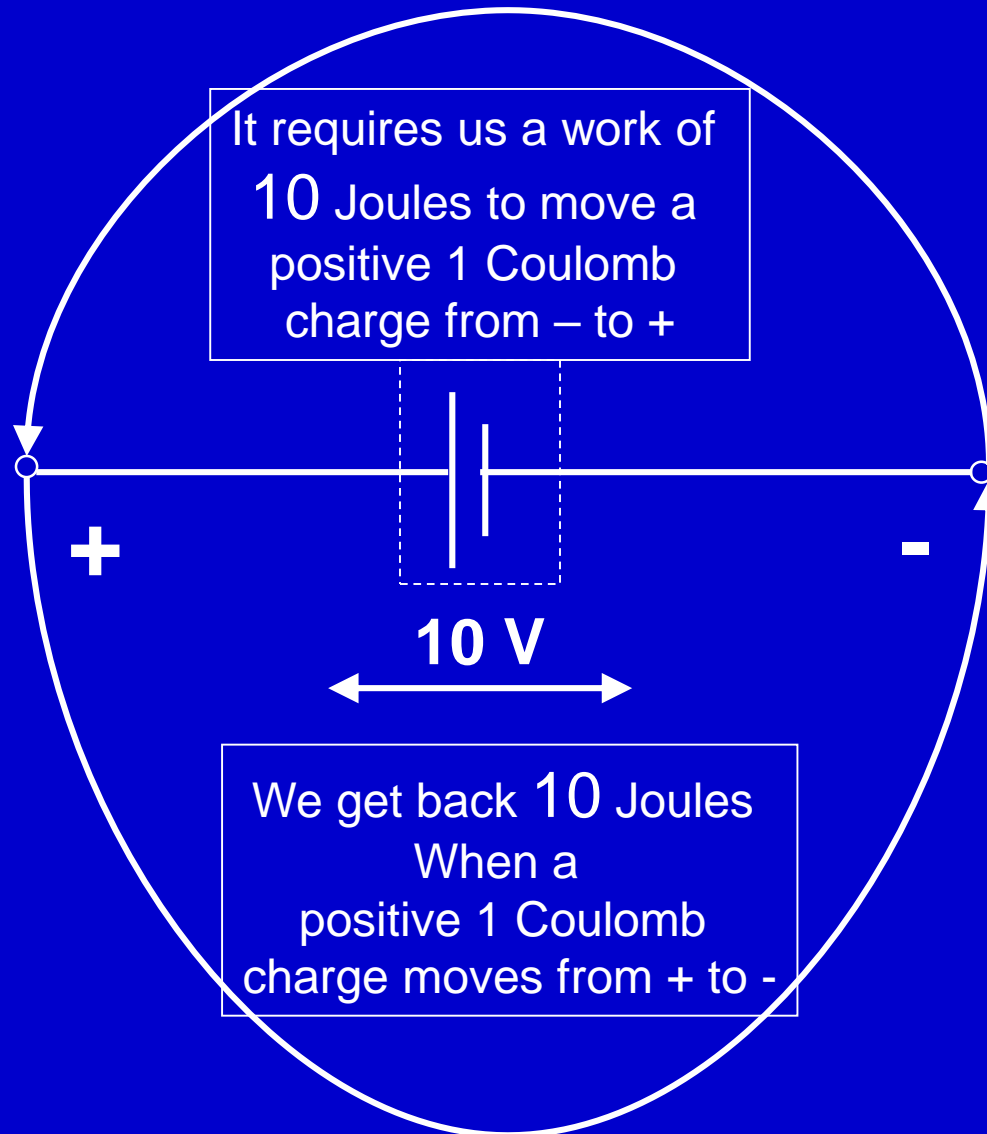

# What is current source?

It is a device (e.g. battery) that guarantees that a prescribed amount of current flows from one terminal to the other.

As an example, consider the current source

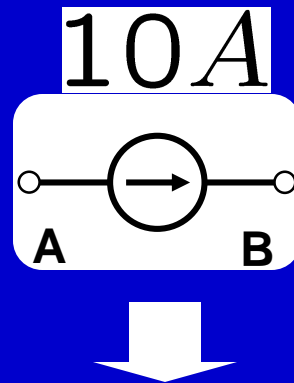

This current source tells us that it will guarantee that 10 Amperes (i.e., 10 Coulombs/Sec) will come OUT from Terminal B

Now that we have talked about **SOURCES** of electrical phenomena which generate energy, let us talk about the elements which **CONSUME** energy.

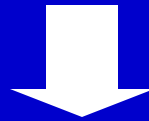

# Resistors

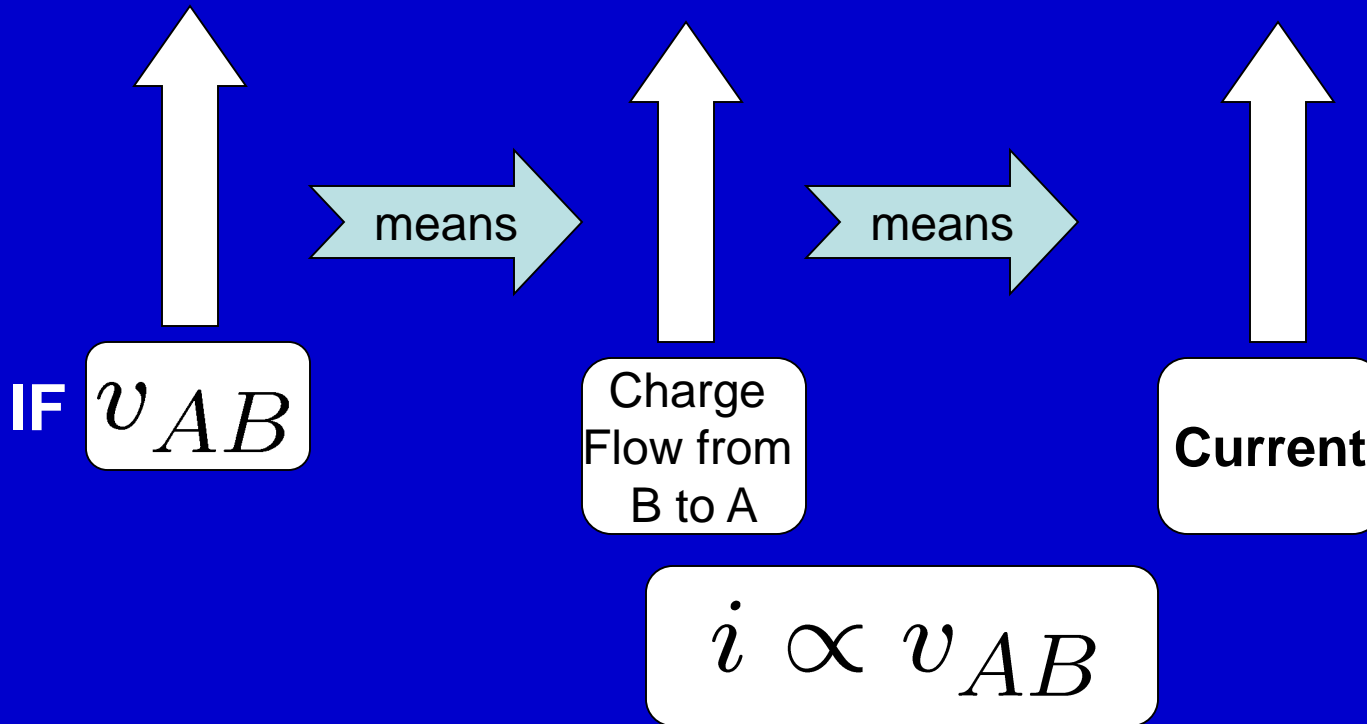
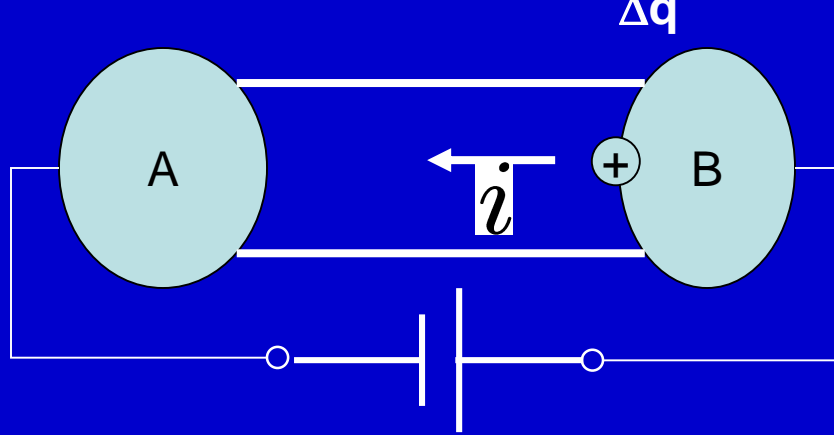

But it took really a smart guy to figure out what is going on between the voltage and current. → WHO? George Simon Ohm

# Georg Simon Ohm

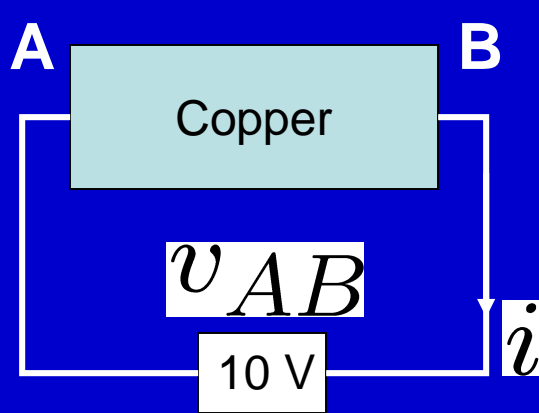

$$i = 5 A$$

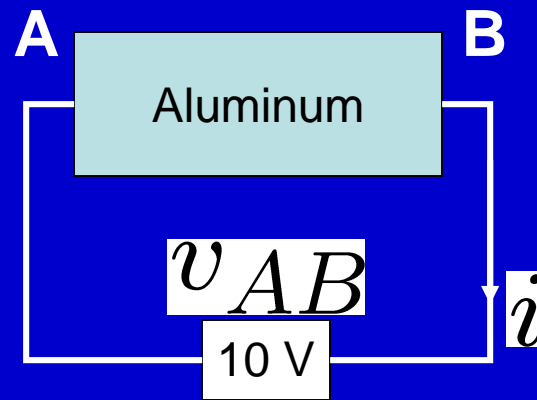

$$i = 2 A$$

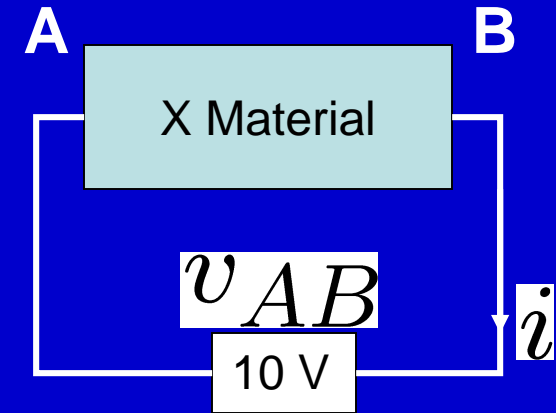

$$i = 0.0001 A$$

Ohm's  
Law

$$i = \frac{v}{R}$$

Resistance  
Which is  
Material  
Dependent

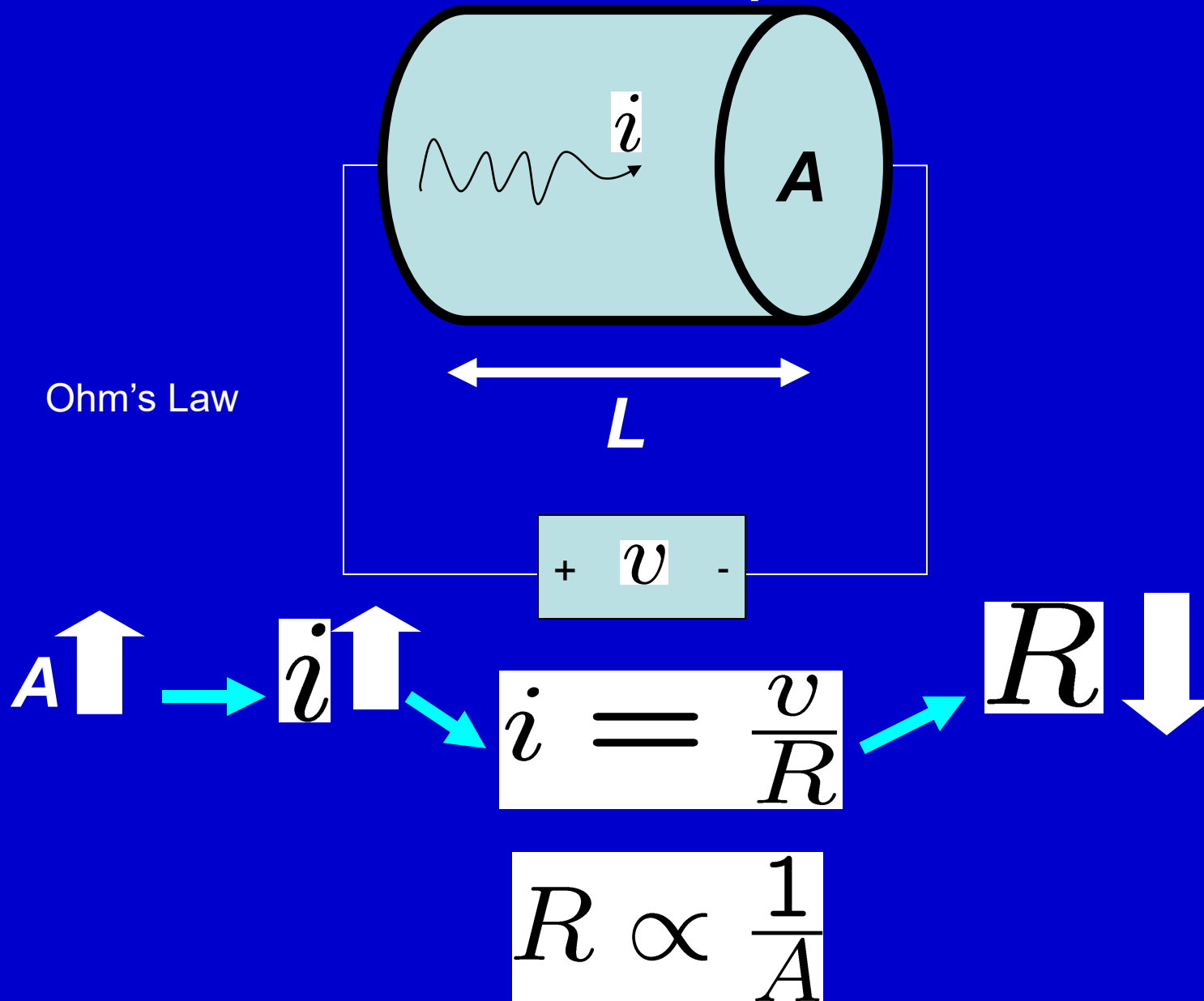
How to compute  $R$ 

## How to compute R

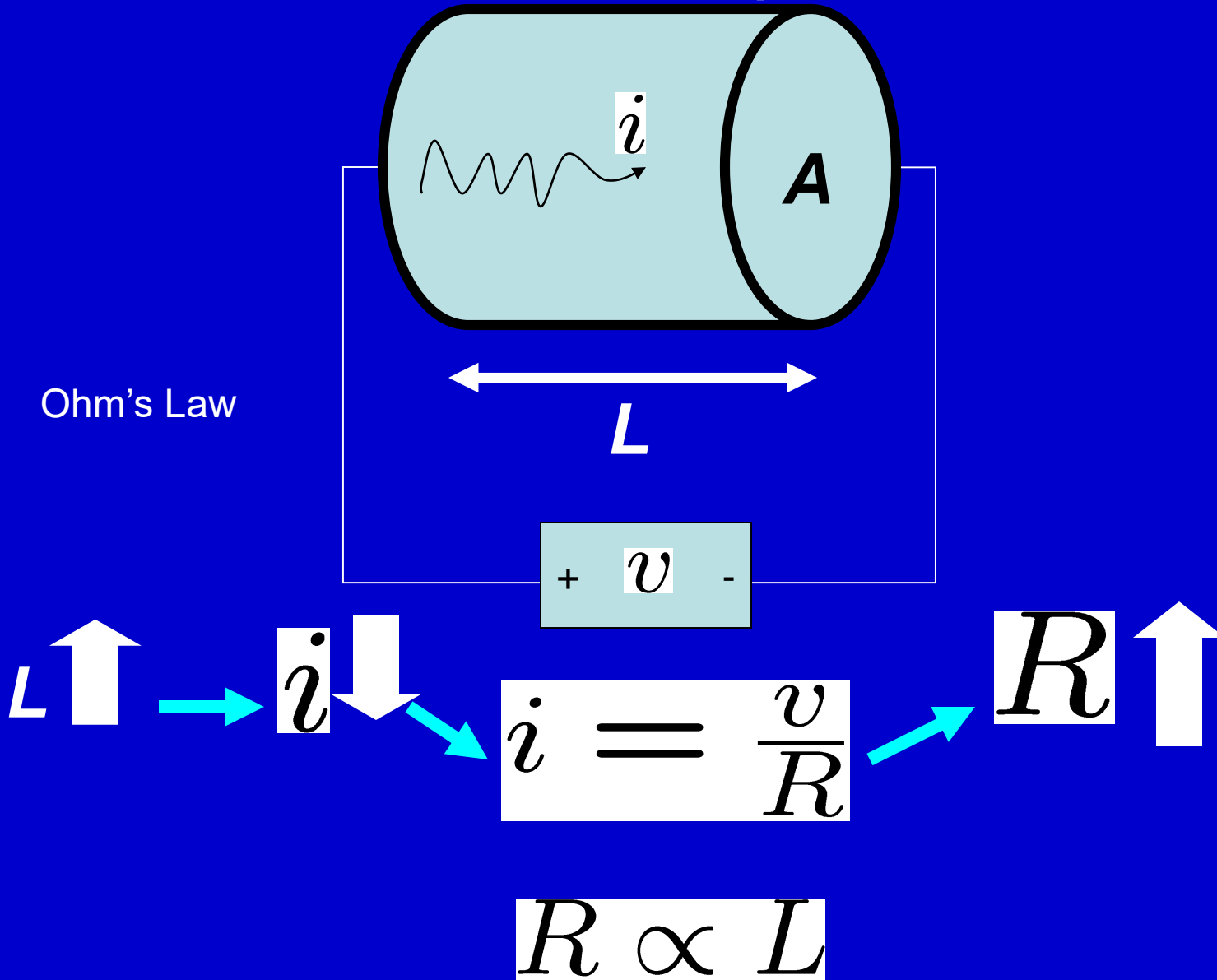

# Ohm's Law

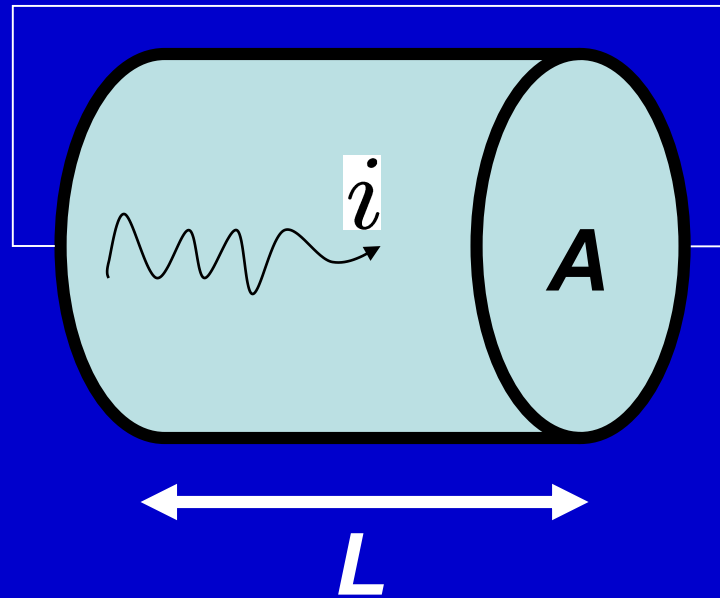

Length

$$R = \frac{\rho L}{A}$$

The equation shows resistance  $R$  equal to the product of resistivity  $\rho$  and length  $L$ , divided by the cross-sectional area  $A$ . A small box above the equation contains a plus sign, the letter  $v$ , and a minus sign, representing voltage. The terms  $\rho$ ,  $L$ , and  $A$  in the equation are circled.

In units of  $\Omega$

Material Dependent

Area

# Resistors in the lab

- In the lab, resistors are manufactured and ready for use. The question is how to know their values?? → Use Color code
- Each color represents a number
- There is a table that shows the number corresponding to each color
- The first three colors represent the value
- The last color represents the tolerance

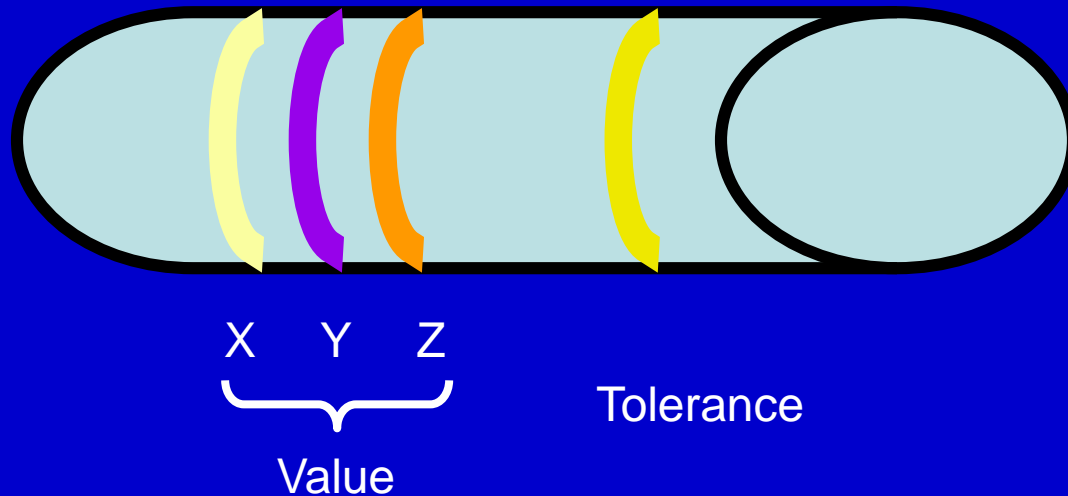

# Steps for reading resistor values

1. From First Color → Get First digit (Use the table)  
Example:- if First Color = YELLOW then first digit = 4
2. From Second Color → Get Second digit  
Example:- if Second color = VIOLET, then first digit = 7
3. From Third color → Get Multiplier the digit ( $10^x$ )  
Example:- if Third color = ORANGE, then we multiply by  $10^3$
4. From Fourth color determine the tolerance  
Example:- if Fourth color = GOLDEN, then tolerance = 5 %

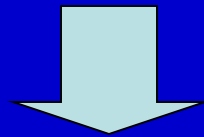

Value of Resistor =  $47 \times 10^3 \pm 5\% \Omega$

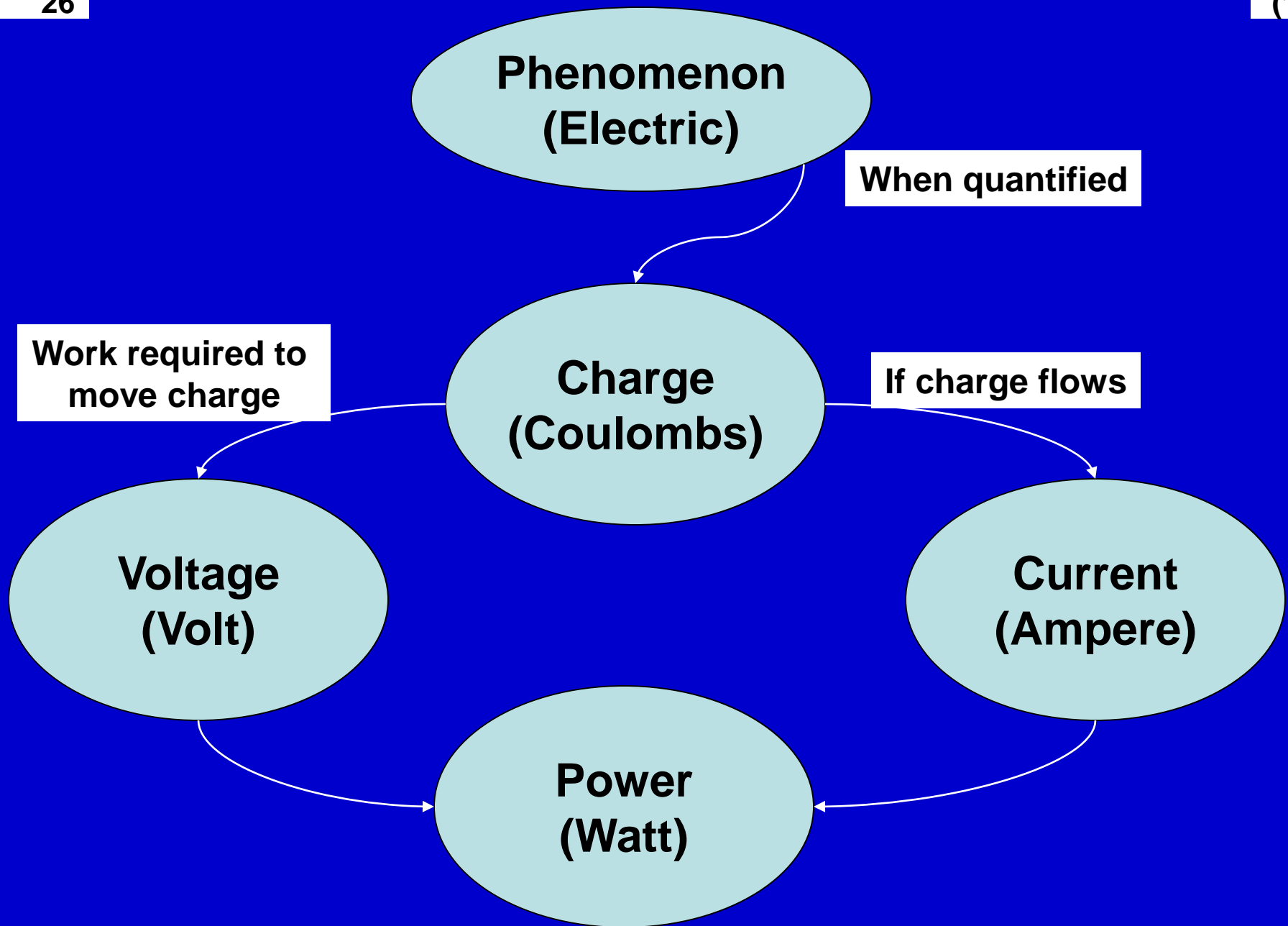

# Waveforms of Sources of Electricity

We have seen sources (current and voltages) which generate, a prescribed **CONSTANT** amount of electrical phenomena. But are there sources (whether current or voltages) that generate a **variable** (i.e., time-dependent ) electrical phenomena

# Waveforms of Sources of Electricity

In this course we will be dealing with two types of electrical sources

## Constant

Voltage or (Current)

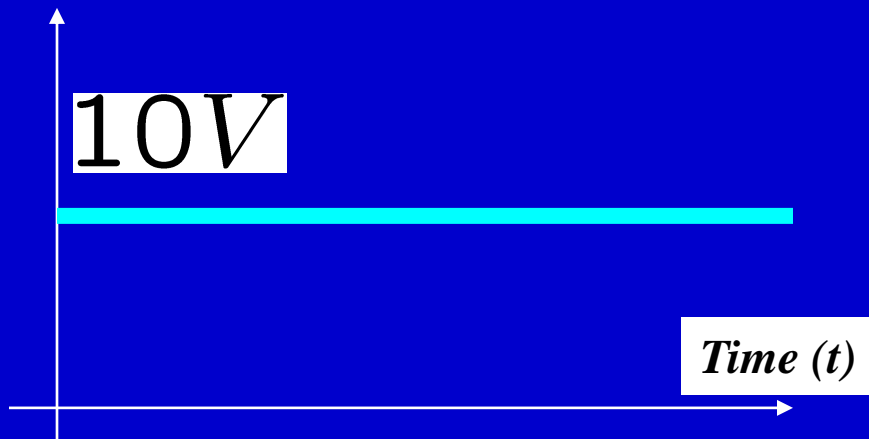

Here the voltage and current remain constant at all times, i.e., their values never vary

$$v(t) = \text{Constant}$$

## Sinusoidal

Voltage or (Current)

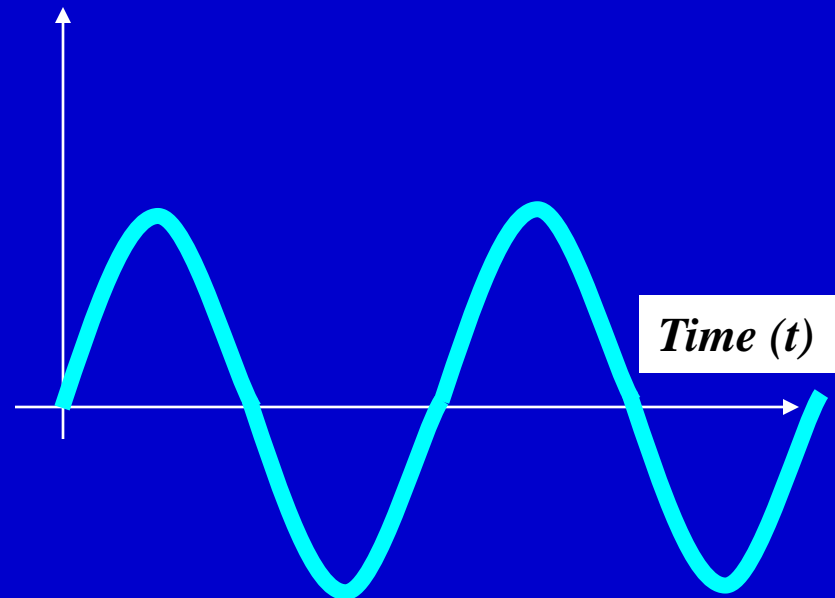

$$v(t) = V_p \cos(\omega t + \theta)$$

# Waveforms of Sources of Electricity

Here, we take a closer look at the sinusoidal sources

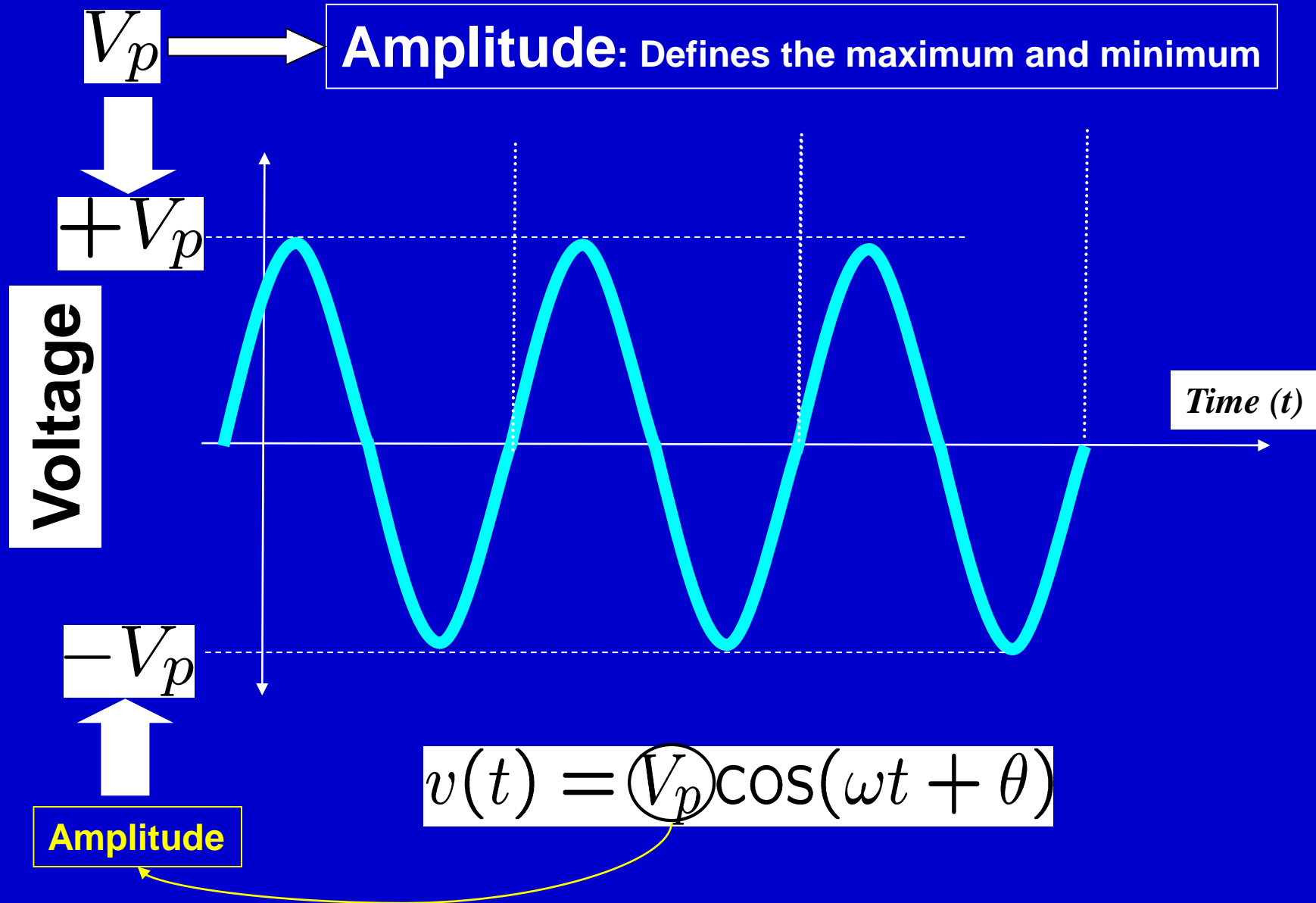

# Waveforms of Sources of Electricity

Here, we take a closer look at the sinusoidal sources

$\omega$   $\longrightarrow$  **Frequency:** tells us how many cycles per one Second

$T$   $\longrightarrow$  **Period:** the length of one cycle in Seconds

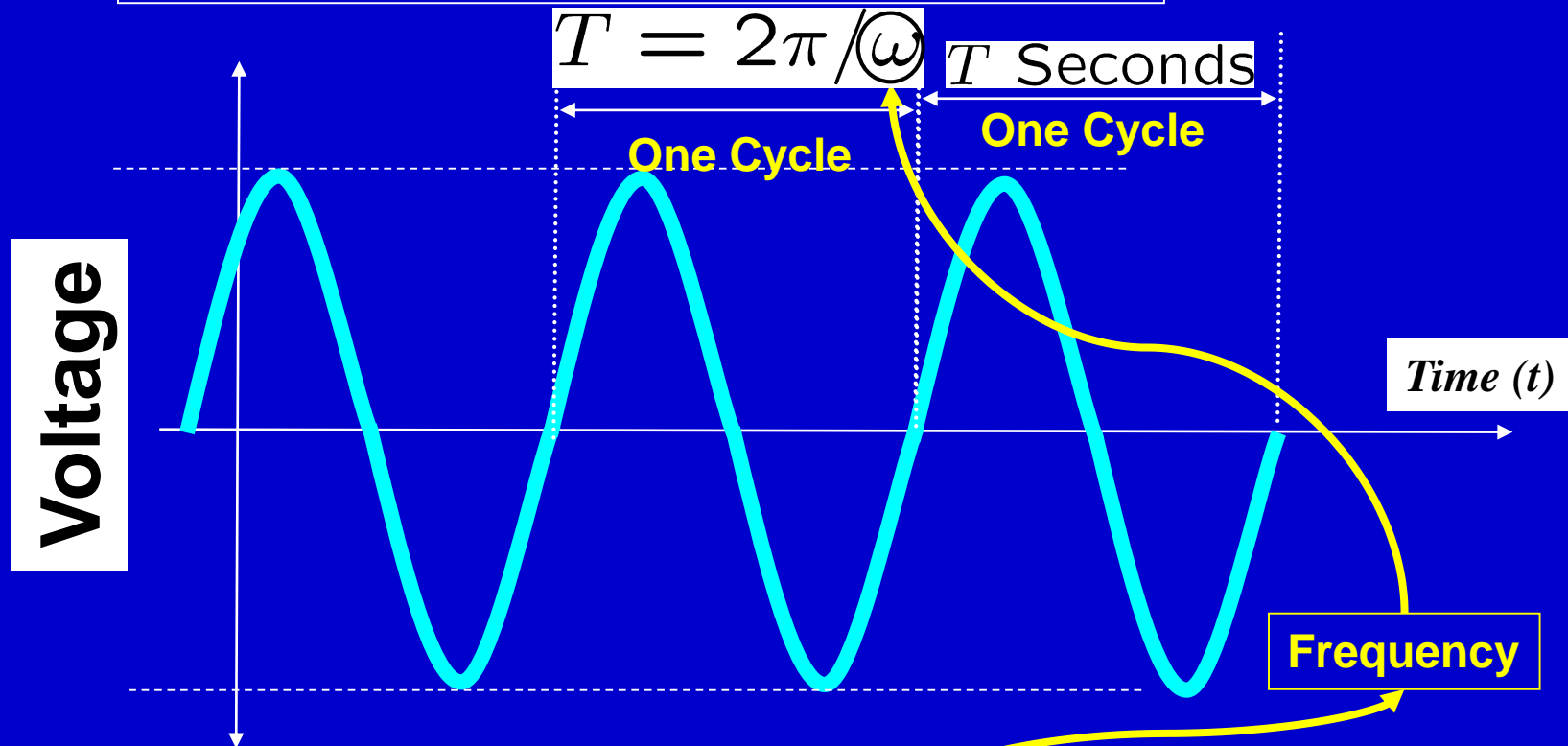

$$v(t) = V_p \cos(\omega t + \theta)$$

# Waveforms of Sources of Electricity

Here, we take a closer look at the sinusoidal sources

 $\theta$ 

**Phase Angle:** tells us about the shift in the starting of the sinusoidal waveform. It is measured in degrees.

**Voltage**

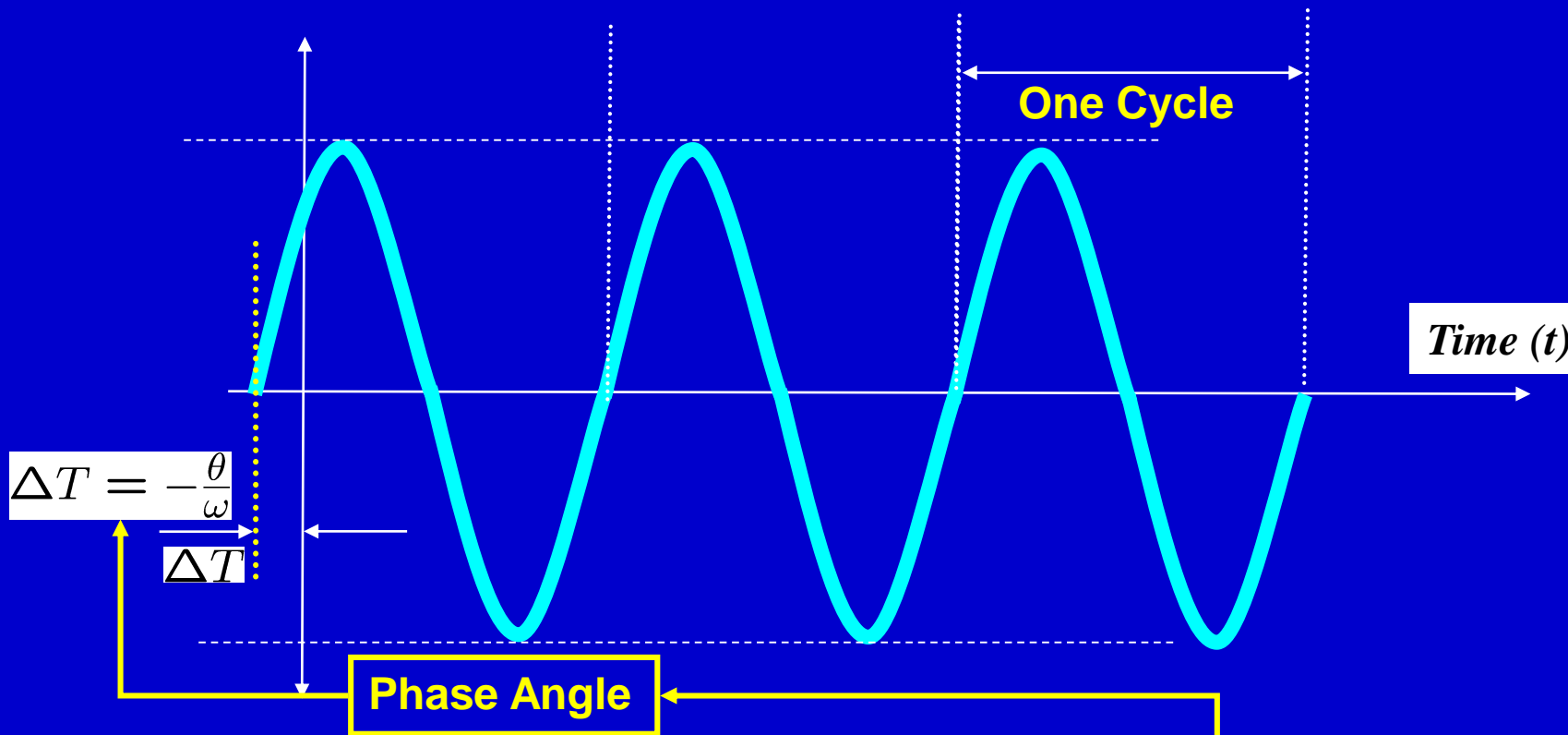

$$v(t) = V_p \cos(\omega t + \theta)$$

# Waveforms of Sources of Electricity

Here, we take a closer look at the sinusoidal sources

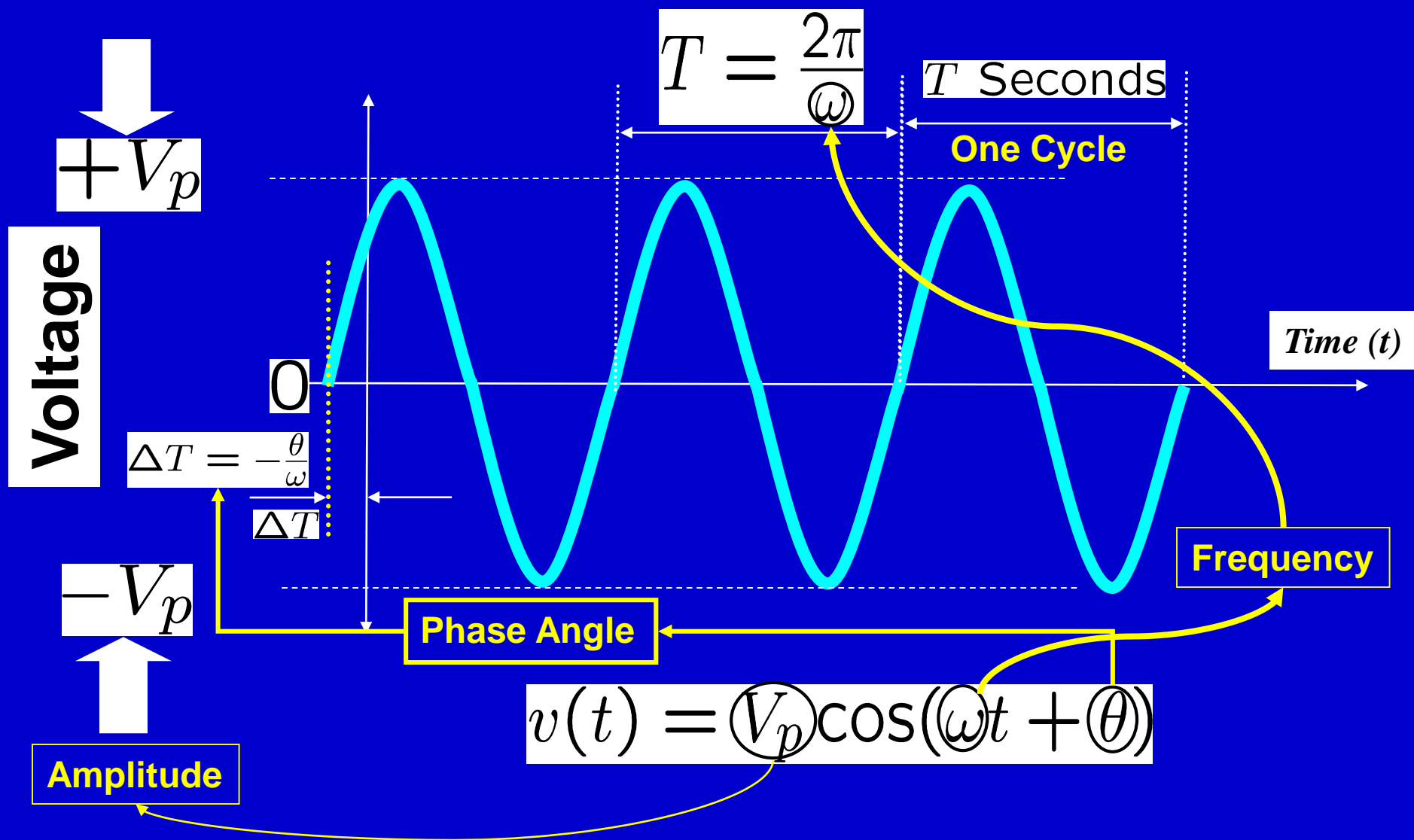

# SI Units

- Here we look at the some of the SI units used to measure the different electric quantities handled in this course.
- There are fundamental units which quantify very basic physical quantities, which are mass, Length, Time, Light intensity.