

CARLETON UNIVERSITY
Department of Mechanical and Aerospace Engineering
ENGINEERING MAAE 2300 - FLUID MECHANICS I
Example Final Examinations

Answers:

December 2010

1. $h = 0.403 \text{ ft.}$
2. Upper bolt: $F = 23500 \text{ N}$
Lower bolt: $F = 47100 \text{ N}$
3. (a) $D_3 = 0.05 \text{ m}$
(b) $h = 35.2 \text{ m}$
(c) $F = -371.3 \text{ N}$ (tensile)
4. $N = 49.6 \text{ RPM}$
5. (a) $H_{\text{pump}} = 342.1 \text{ m of water}$
 $d\dot{W}/dt_{\text{shaft}} = 1049 \text{ kW}$
(b) Will need at least 2 pumps
(c) 0.89°C

December 2009

1. $h = 2.66 \text{ ft.}$
2. (a) $P_1(\text{g}) = -5.0 \times 10^3 \text{ Pa(g)}$
 $P_2(\text{g}) = 7.51 \times 10^3 \text{ Pa(g)}$
(b) $\dot{m} = 81.5 \text{ kg/s}$
3. (a) $V_2 = 6.48 \text{ m/s}$
(b) $F = 1.025 \times 10^4 \text{ N}$
(c) $\frac{dW}{dt} = \dot{W} = 114.7 \text{ HP}$
4. (a) $\dot{m} = 60.7 \text{ kg/s}$
(b) $\dot{W}_{\text{shaft}} = 141.4 \text{ HP}$
(c) $T_{\text{chamber}} = 293.49 \text{ K}$ (compared with $T_{\text{atm}} = 293 \text{ K}$)
Applying the perfect gas law, $\rho_{\text{chamber}} = 1.219 \text{ kg/m}^3$ compared with $\rho_{\text{atm}} = 1.201 \text{ kg/m}^3$

5. (a) $\varepsilon = 4.6 \text{ mm}$
 (b) (i) $\dot{W}_{shaft} = 19.8 \text{ HP}$
 (ii) $L_{old} = 535 \text{ m}$ (length to be replaced)

December 2006

1. Note: you are asked for the net fluid force. P_{atm} contributes to the pressure on both sides. Therefore, you only need to determine hydrostatic force on the water side.
 $F_R = 164100 \text{ N}$. $y_R = 1.087 \text{ m}$, measured from top edge of window.
2. (a) $Q = 0.421 \text{ l/min}$
 (b) $Q = 0.493 \text{ l/min}$
3. (a) $P_A = 97,095 \text{ Pa}$ (a). Given that this is air, would there be any noticeable change in the pressure between A and the lower manometer?
 $P_B = 101,680 \text{ Pa}$ (a)
 (b) $F_X = 1890 \text{ N}$ to the right
 (c) $M_Z = 5671 \text{ Nm}$
 (d) Increase. Why?
 (e) 46.4 HP
4. (a) $P = 391.7 \text{ kPa(g)}$
 (b) $F_B = 6456 \text{ N}$ in tension
5. (a) $P = 662.5 \text{ kPa(g)}$
 (b) $F = 3731 \text{ N}$. There is no friction on the outside of the hose. However, the water flowing through the hose does of course exert a frictional force on the inside of the hose.
 (c) $V = 15.3 \text{ m/s}$
 (d) Yes. Consider the Reynolds numbers and relative roughness for the two cases.

CARLETON UNIVERSITY

Final
EXAMINATION
December 2010

DURATION: **3** HOURS

No. of Students: **121**

Department Name & Course Number: **Mechanical & Aerospace Engineering, MAAE 2300A**

Instructor(s) **S.A. Sjolander**

AUTHORIZED MEMORANDA

1 sheet 8 1/2 x 11, both sides, any non-transmitting calculator

Students **MUST** count the number of pages in this examination question paper **before** beginning to write, and report any discrepancy immediately to a proctor. This question paper has **6** pages.

This examination question paper **MAY** be taken from the examination room.

ATTEMPT ALL QUESTIONS. THE VALUE OF EACH QUESTION IS GIVEN IN THE MARGIN. DRAW COMPLETE AND FULLY-LABELLED FREE-BODY DIAGRAMS OR CONTROL VOLUMES WHERE APPROPRIATE.

Geometric properties of common cross sections:

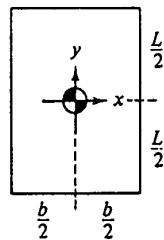

$$A = bL$$

$$I_{xx} = \frac{bL^3}{12}$$

$$I_{xy} = 0$$

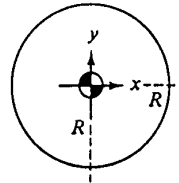

$$A = \pi R^2$$

$$I_{xx} = \frac{\pi R^4}{4}$$

$$I_{xy} = 0$$

Miscellaneous

s data:

Air: $R = 287 \text{ Nm/kgK}$
 $C_p = 1005 \text{ Nm/kgK}$
 $C_v = 716 \text{ Nm/kgK}$

Water: $\rho = 1000 \text{ kg/m}^3$
 $= 62.4 \text{ lb}_m/\text{ft}^3$
 $C_v = 4180 \text{ Nm/kgK}$

$$^{\circ}\text{R} = ^{\circ}\text{F} + 460$$

$$^{\circ}\text{K} = ^{\circ}\text{C} + 273$$

$$1 \text{ litre} = 1000 \text{ cm}^3$$

$$g = 32.174 \text{ ft/sec}^2$$

$$= 9.81 \text{ m/s}^2$$

$$1 \text{ HP} = 550 \text{ ft-lb}_f/\text{sec}$$

$$= 745 \text{ Nm/s}$$

$$1 \text{ ft} = 12 \text{ inches}$$

$$1 \text{ slug} = 32.174 \text{ lb}_m$$

See Page 6 for additional data.

1. Water is flowing steadily at $4 \text{ ft}^3/\text{s}$ through the pipe shown. Treating water as an inviscid, incompressible fluid with a density $\rho = 62.4 \text{ lb}_m/\text{ft}^3$, determine the value of h .

[15]

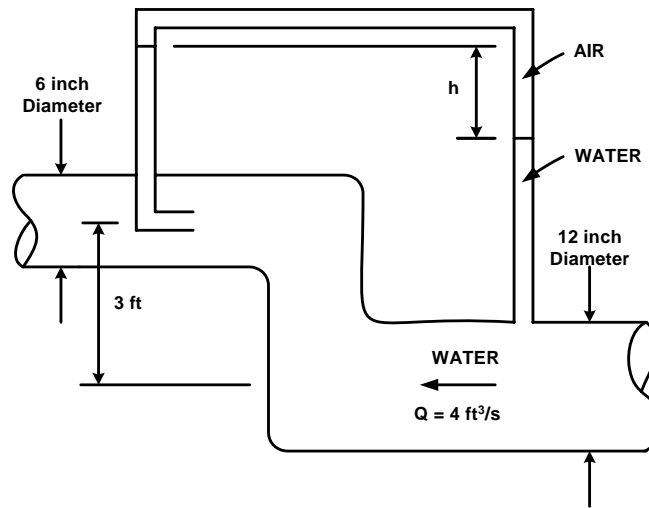

2. When concrete is poured into forms, the forces on the forms can be estimated by assuming that the freshly poured concrete behaves as a liquid with a density of $2400 \text{ kg}/\text{m}^3$. The forms for a long concrete wall 10 cm thick and 2 m high are held together by bolts spaced every 1.5 m, as shown in the drawing. The bolts are right at the top and the bottom of the concrete. What is the force in each upper bolt? In each lower bolt? State clearly whether each bolt is in tension or compression.

[20]

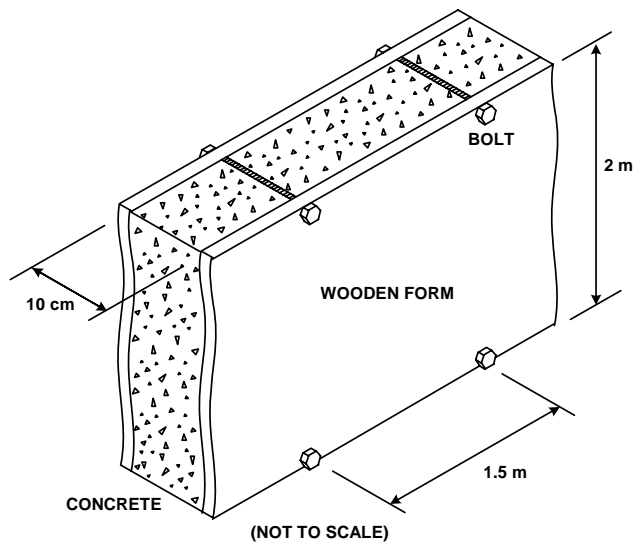

3. The drawing shows an ornamental water fountain. Water with a flow rate of $0.05 \text{ m}^3/\text{s}$ leaves the nozzle at plane 2 at a depth of 1 m below the free surface. The jet of water then rises through the pool of water and continues to a height h above the free surface. The nozzle is attached to the main pipe by a flanged joint at plane 1. The pressure gauge indicates that the pressure in the flow inside the pipe at plane 1 is 400 kPa(a) . The nozzle (from plane 1 to plane 2) has a total weight of 100 N . Assume that the water can be treated as incompressible and inviscid. Also, assume that the walls of the nozzle are thin compared with the radius.

- [5] (a) What is the diameter of the jet, D_3 , as passes through the water surface at plane 3?
- [5] (b) What vertical height h will the jet reach?
- [10] (c) Determine the force in the y direction at the flanged joint at plane 1. Indicate clearly whether the flanged joint is in tension or compression.

[20]

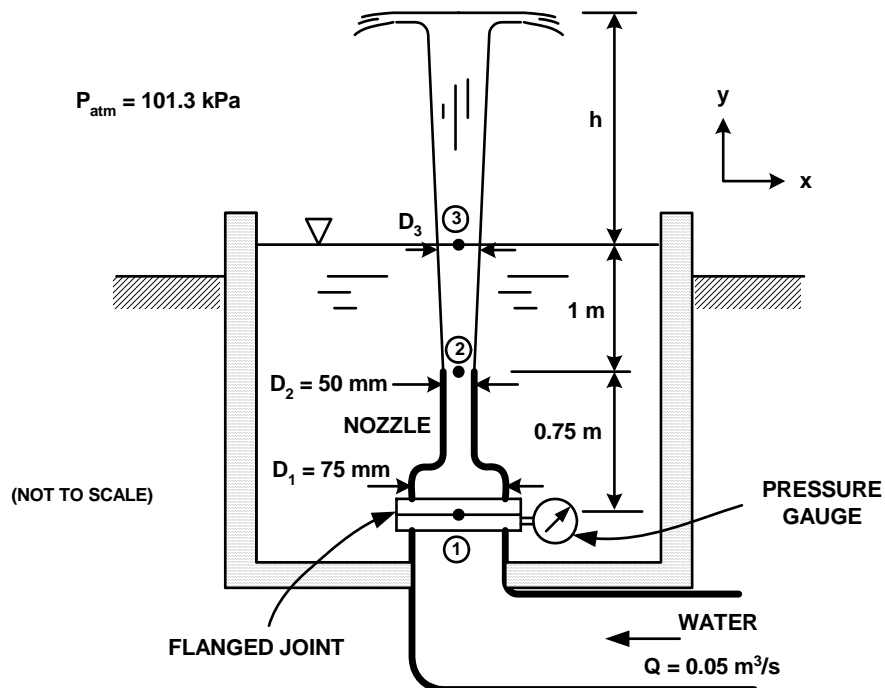

4. The drawing shows the rotating spray bar in the top of a dishwasher. Water enters the spray bar through the pivot with no swirl (no tangential velocity). The water leaves the spray bar through the six nozzles, causing it to rotate. The nozzles point downward towards the dishes at an angle of 40° , as shown. The total flow rate of water is 15 litres per minute. Each of the six nozzles has an inner diameter of 5 mm and the flow rate is the same for each of the nozzles. Assume that the friction in the pivot holding the spray bar can be neglected. Estimate the rotation rate of the spray bar in revolutions per minute. Recall that $1 \text{ m}^3 = 1000 \text{ litres}$.

[20]

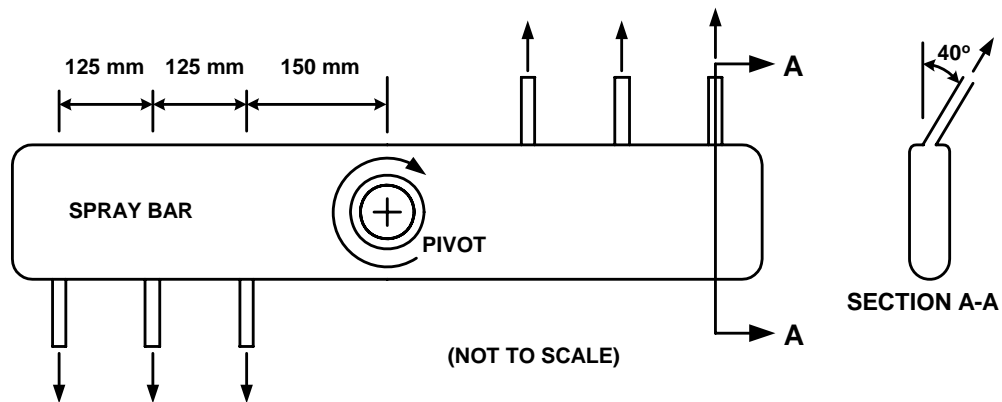

5. Water is to be pumped from a filtration plant to a remote storage tank through a 30 cm diameter cast iron pipeline. The pipeline is 7 km long and has six 90° elbows, each with a loss coefficient $K = 0.25$. The flow rate is to be $15 \text{ m}^3/\text{min}$. The viscosity, ν , of the water is $10^{-6} \text{ m}^2/\text{s}$.
- [12] (a) Determine the total head rise across the pump(s). What is the power, in kW, required to drive the pump(s) if the pump(s) have an efficiency of 80%?
- [8] (b) The 30 cm diameter class H cast iron pipe which is being used can withstand a maximum internal pressure of 2400 kPa(g). Also, to avoid cavitation (which involves the formation of vapour bubbles in the water) the pressure at any pump inlet must be greater than 5 kPa(a). Determine whether it is necessary to use more than one pump to achieve the required head rise while staying within the specified pressure limits. The pump(s) may be located anywhere along the pipeline between the valve and the storage tank. Explain your reasoning clearly.
- [5] (c) What is the temperature change in the water over the 7 km length of pipeline, assuming that there is no heat transfer to or from the pipe?

[25]

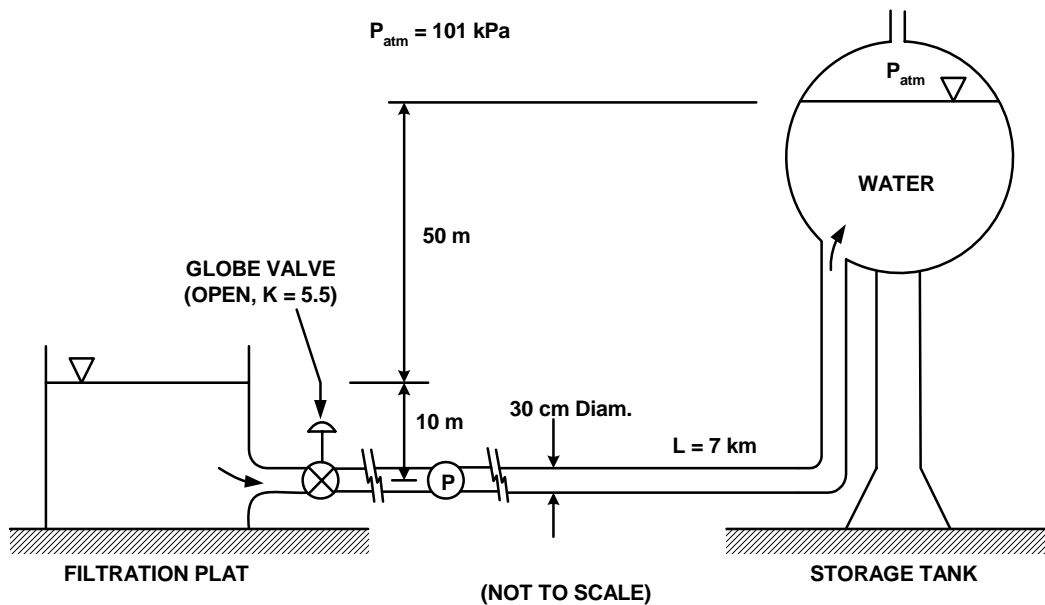

CARLETON UNIVERSITY

Final
EXAMINATION
December 2009

DURATION: **3** HOURS

No. of Students: **120**

Department Name & Course Number: **Mechanical & Aerospace Engineering, MAAE 2300A**

Instructor(s) **S.A. Sjolander**

AUTHORIZED MEMORANDA

1 sheet 8 1/2 x 11, both sides, any non-transmitting calculator

Students **MUST** count the number of pages in this examination question paper **before** beginning to write, and report any discrepancy immediately to a proctor. This question paper has **7** pages.

This examination question paper **MAY** be taken from the examination room.

ATTEMPT ALL QUESTIONS. THE VALUE OF EACH QUESTION IS GIVEN IN THE MARGIN. DRAW COMPLETE AND FULLY-LABELLED FREE-BODY DIAGRAMS OR CONTROL VOLUMES WHERE APPROPRIATE.

Geometric properties of common cross sections:

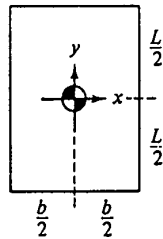

$$A = bL$$

$$I_{xx} = \frac{bL^3}{12}$$

$$I_{xy} = 0$$

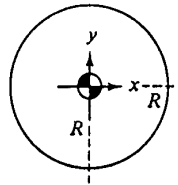

$$A = \pi R^2$$

$$I_{xx} = \frac{\pi R^4}{4}$$

$$I_{xy} = 0$$

Miscellaneous data:

Air: $R = 287 \text{ Nm/kgK}$
 $C_p = 1005 \text{ Nm/kgK}$
 $C_v = 716 \text{ Nm/kgK}$

Water: $\rho = 1000 \text{ kg/m}^3$
 $= 62.4 \text{ lb}_m/\text{ft}^3$
 $C_v = 4180 \text{ Nm/kgK}$

$$^{\circ}\text{R} = ^{\circ}\text{F} + 460$$

$$^{\circ}\text{K} = ^{\circ}\text{C} + 273$$

$$1 \text{ litre} = 1000 \text{ cm}^3$$

$$g = 32.174 \text{ ft/sec}^2$$

$$= 9.81 \text{ m/s}^2$$

$$1 \text{ HP} = 550 \text{ ft-lb}_f/\text{sec}$$

$$= 745 \text{ Nm/s}$$

$$1 \text{ ft} = 12 \text{ inches}$$

$$1 \text{ slug} = 32.174 \text{ lb}_m$$

See Page 7 for additional data.

1. The drawing shows a large open tank containing water. The right-angle gate has negligible mass, is 2 ft wide in the horizontal direction and can rotate about the hinge. There is no friction in the hinge. The horizontal portion of the gate covers the opening of the 12 inch diameter drain pipe. The drain pipe is open to the atmosphere. When the height of the water is greater than h , the gate rotates to uncover the drain pipe and this allows water to flow out. This prevents water from overflowing the top of the tank. What is the value of h in ft?

[15]

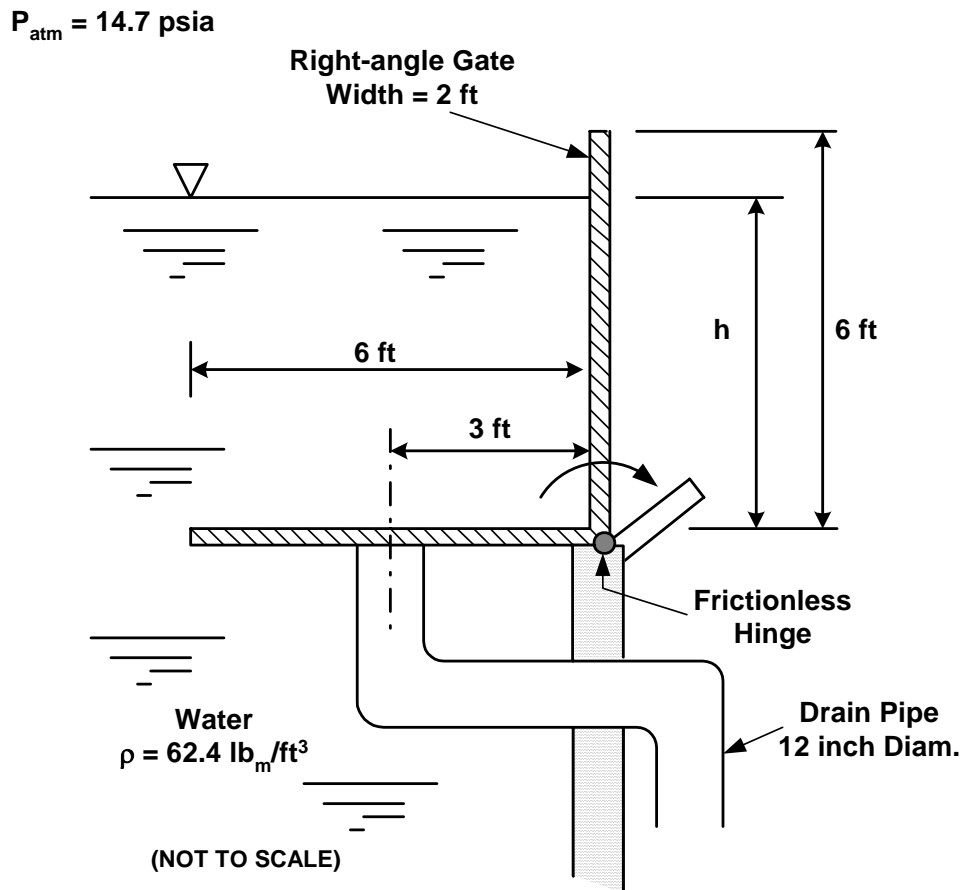

2 Oil (S.G. = 0.85) is flowing through the vertical pipe shown in the drawing. Neglect friction in your analysis. State any other simplifying assumptions used.

[5] (a) Determine the gauge pressures in Pa(g) measured by the two manometers at locations 1 and 2 in the flow.

[10] (b) Determine the mass flow rate of oil for the conditions shown.

[15]

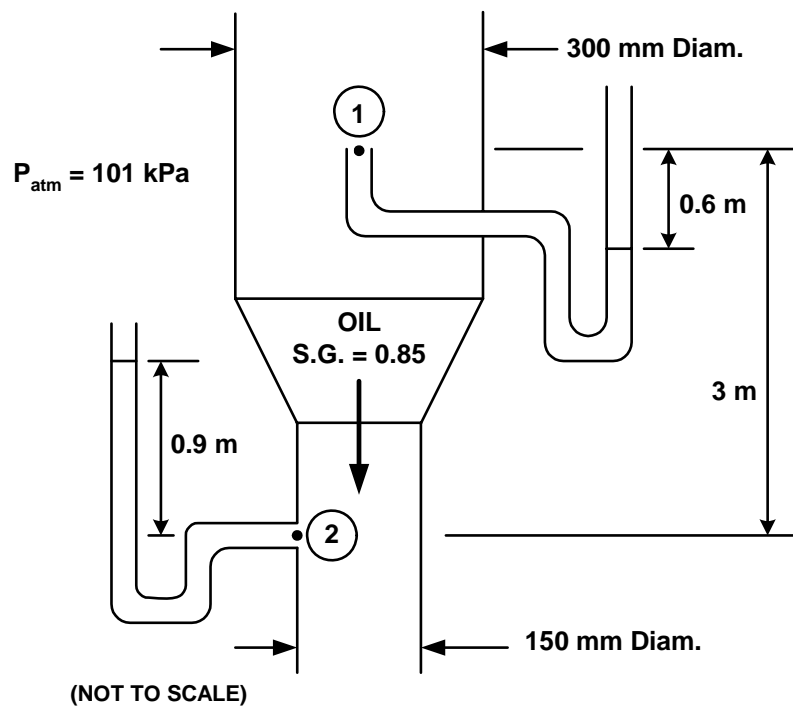

4. The drawing shows an air-cushion vehicle (hovercraft) used for transporting passengers. Air is drawn into the chamber by the fan and discharged at high velocity through the 3 cm gap (not shown to scale) between the bottom of the chamber and the ground. The chamber is 10 m long, 6 m wide and 2 m high. The vehicle has a total weight of 100 kN. Atmospheric conditions are $P_{\text{atm}} = 101 \text{ kPa}$ and $T_{\text{atm}} = 20^\circ \text{ C}$. For parts (a) and (b) assume that the air can be treated as a perfect gas and has the same density everywhere as that for the atmospheric air. State any additional assumptions made.
- [12] (a) Estimate the mass flow rate of air through the fan. Hint: the air in the chamber (region 1) is essentially stagnant and supports the vehicle.
- [8] (b) If the fan has an efficiency of 80%, estimate the shaft power, in HP, required to drive the fan.
- [5] (c) Estimate the temperature of the air inside the chamber. Is the assumption reasonable that the density in the air in the chamber is the same as that of the atmospheric air? Support your answer quantitatively.

[25]

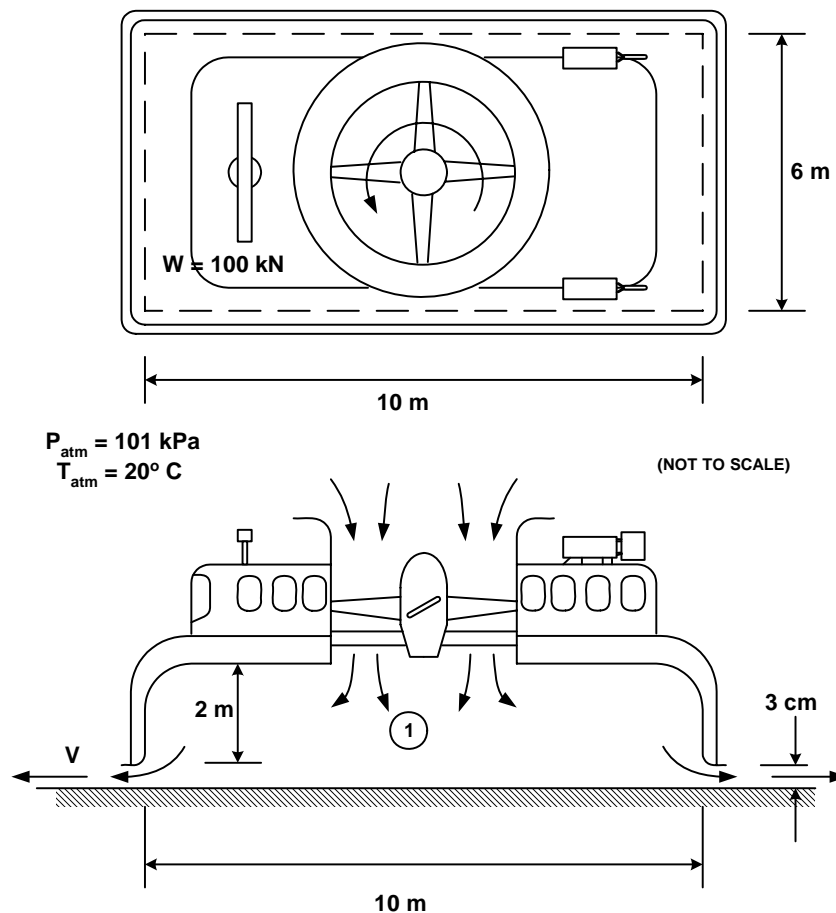

5. Irrigation water is drawn from the pond created by a dam in a small river. The 20 cm. diameter pipe discharges the water at atmospheric pressure 1000 m from the pond at an elevation of 15 m below the free surface of the pond. There are losses at the intake and through the open valve, as indicated on the drawing. The only other source of losses is friction in the pipe. The system was originally designed to deliver a flow rate of water of 200 m³/hr of water. After some years, the farmer realizes that the water flow rate has decreased to 120 m³/hr. He suspects that fouling and corrosion has increased the roughness of the pipe.

[8] (a) Estimate the average height, in mm, of the roughness which has developed on the inside surface of the old pipe. Assume that the water has a viscosity $\nu = 1.2 \times 10^{-6} \text{ m}^2/\text{s}$.

(b) The farmer decides that he needs to increase the flow rate to 150 m³/hr. He needs to make a choice between leaving the old pipe in place and installing a pump, or replacing part of the pipe length with new pipe. Assume that the average roughness height for the old pipe is 4.5 mm (note that this is not necessarily the value you should have obtained in part (a)).

[7] (i) What head rise would the pump need to produce to obtain the desired flow rate of 150 m³/hr with the old pipe left unchanged? What shaft power, in horsepower, must the electric motor produce to drive the pump if the pump has an efficiency of 65%?

[10] (ii) What length of the old pipe, in metres, must be replaced with new pipe to bring the flow rate up to 150 m³/hr? The new pipe is commercial steel which has an average roughness height of 0.046 mm.

[25]

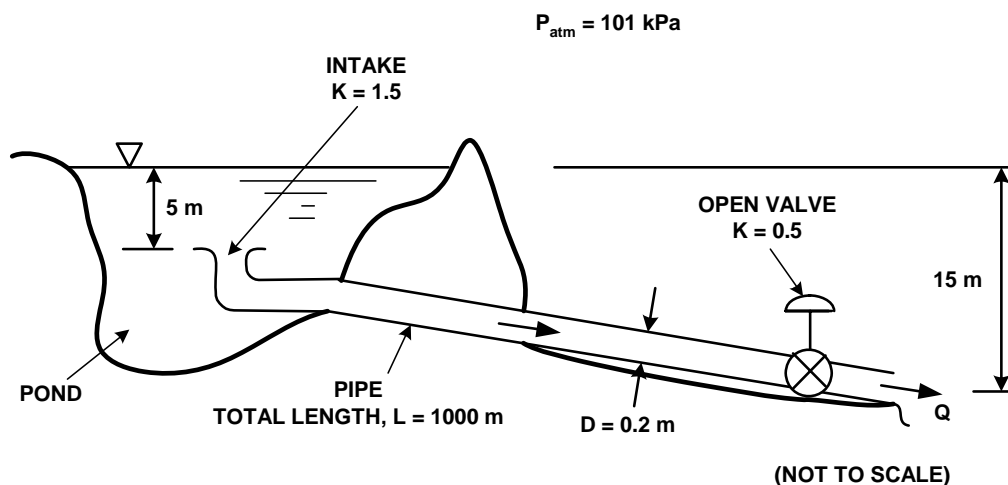

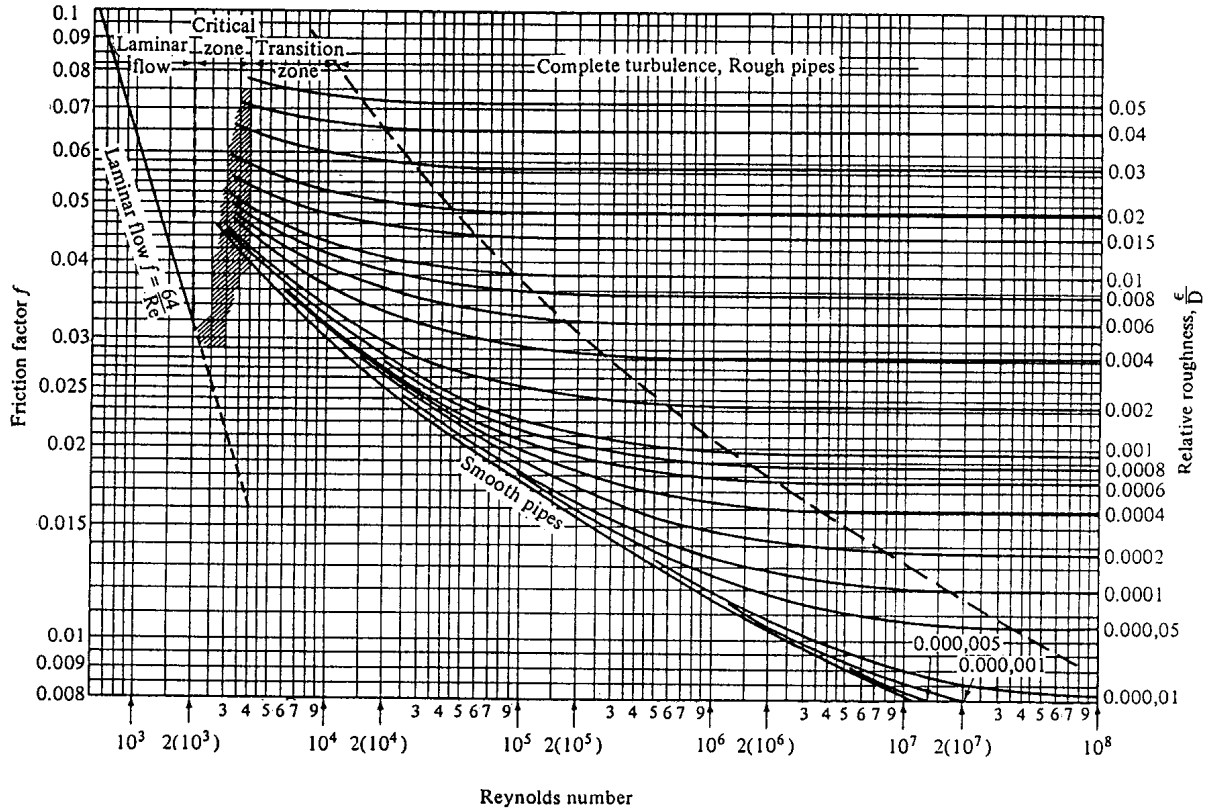

$$f = \frac{h_f}{\frac{LV^2}{D2g}}$$

Reynolds number:

$$Re = \frac{\rho VD}{\mu} = \frac{VD}{\nu}$$

CARLETON UNIVERSITY

Final
EXAMINATION
December 2006

DURATION: **3** HOURS

No. of Students: **111**

Department Name & Course Number: **Mechanical & Aerospace Engineering, MAAE 2300A**

Instructor(s) **S.A. Sjolander**

AUTHORIZED MEMORANDA

1 sheet 8 1/2 x 11, both sides, any non-transmitting calculator

Students **MUST** count the number of pages in this examination question paper **before** beginning to write, and report any discrepancy immediately to a proctor. This question paper has **7** pages.

This examination question paper **MAY** be taken from the examination room.

ATTEMPT ALL QUESTIONS. THE VALUE OF EACH QUESTION IS GIVEN IN THE MARGIN. DRAW COMPLETE AND FULLY-LABELLED FREE-BODY DIAGRAMS OR CONTROL VOLUMES WHERE APPROPRIATE.

Geometric properties of common cross sections:

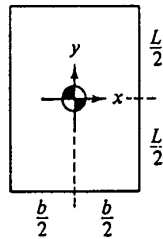

$$A = bL$$

$$I_{xx} = \frac{bL^3}{12}$$

$$I_{xy} = 0$$

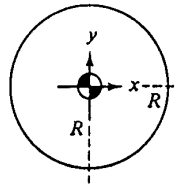

$$A = \pi R^2$$

$$I_{xx} = \frac{\pi R^4}{4}$$

$$I_{xy} = 0$$

Miscellaneous data:

Air: $R = 287 \text{ Nm/kgK}$
 $C_p = 1005 \text{ Nm/kgK}$
 $C_v = 716 \text{ Nm/kgK}$

Water: $\rho = 1000 \text{ kg/m}^3$
 $= 62.4 \text{ lb}_m/\text{ft}^3$
 $C_v = 4180 \text{ Nm/kgK}$

$$^{\circ}\text{R} = ^{\circ}\text{F} + 460$$

$$^{\circ}\text{K} = ^{\circ}\text{C} + 273$$

$$1 \text{ litre} = 1000 \text{ cm}^3$$

$$g = 32.174 \text{ ft/sec}^2$$

$$= 9.81 \text{ m/s}^2$$

$$1 \text{ HP} = 550 \text{ ft-lb}_f/\text{sec}$$

$$= 745 \text{ Nm/s}$$

See Page 7 for additional data.

1. The drawing shows a large fish tank at a public aquarium. For viewing the fish, the tank has a series of rectangular glass windows mounted in the wall. Each window is 3 m wide in the horizontal direction and 2 m in length in the other direction, as shown. Determine the net fluid force on the window and the line of action of the force measured from the top edge of the window.

[15]

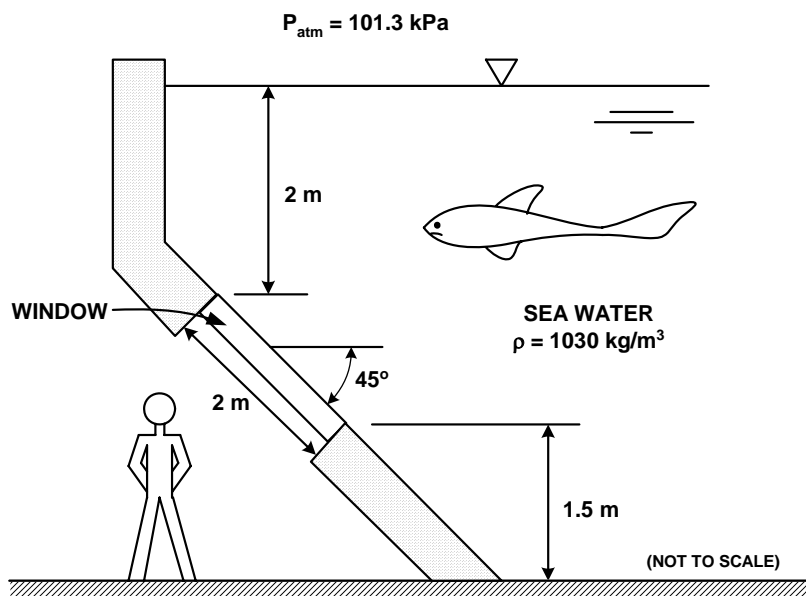

- 2 The drawing shows a simple insecticide sprayer that is intended to be attached to a garden hose. The insecticide is drawn from the container to mix with the water and the mixture is then sprayed through the 2.5 mm diameter outlet nozzle. Neglect friction in your analysis. State any other simplifying assumptions used.
- [12] (a) What is the flow rate of water in litres/min (recall that $1 \text{ m}^3 = 1000 \text{ litres}$) for the conditions shown in the drawing? As indicated in the sketch, the insecticide has been drawn up the 1.0 mm diameter tube but is not flowing into the sprayer tube.
- [8] (b) The recommended mixture is 10 parts water to 1 part insecticide. Determine the flow rate of water required to obtain a spray at the nozzle outlet with this mixture. It is possible, although not necessary, to simplify the analysis slightly by using the fact that flow rate of insecticide in the sprayer tube is small compared with the flow rate of water.

[20]

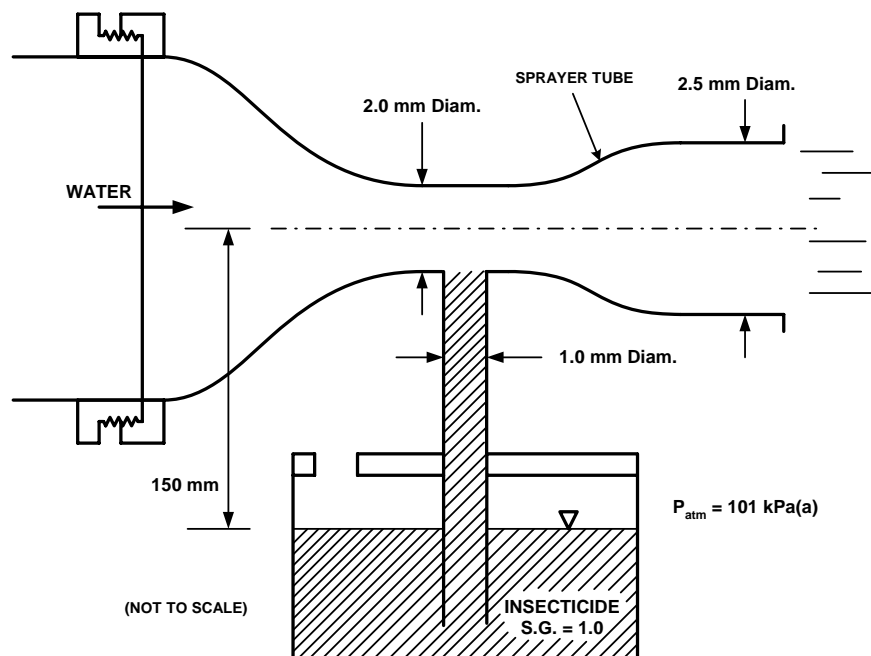

3. The drawing shows a ventilation fan that draws $300 \text{ m}^3/\text{min}$ of air from an underground mine and exhausts it to the atmosphere. The fan and fan duct come as a module that is connected to the upstream and downstream ducts by two flexible couplings. Note carefully all other data given on the drawing. Neglect friction and any density changes in the flow.
- [6] (a) What are the absolute pressures at A and B? State any additional assumptions that you make to obtain your answers.
- [7] (b) Determine the force in the x direction, F_x , which the base of the fan exerts on the ground. Clearly indicate the direction of the force (to the right or the left).
- [4] (c) Determine the moment in the z direction, M_z , that the base of the fan exerts on the ground. Clearly indicate the direction of the moment (clockwise or counterclockwise).
- [3] (d) Supposed that the diffuser is removed such that the air exhausts to the atmosphere at plane B, will the power required to drive the fan increase, decrease or stay the same? Briefly explain your reasoning. Assume that the flow rate and the pressure at the inlet to the fan are the same for the two cases.
- [5] (e) If the fan has an efficiency of 70%, what shaft power, in horsepower, is required to drive the fan for the flow conditions shown in the drawing? Recall that 1 HP = 745 Watts.

[25]

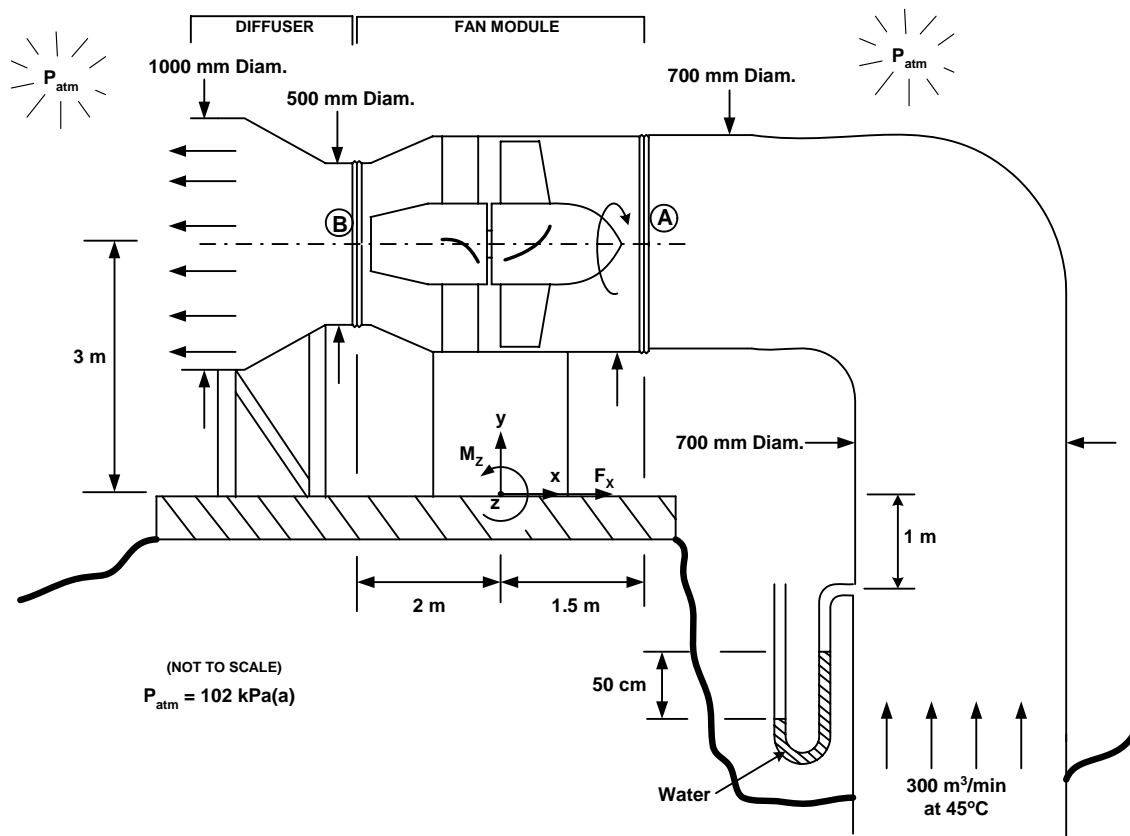

4. The drawing shows a nozzle used in fire fighting. The centrebody can be moved back and forth to adjust the flow rate of water and the spray pattern. For the centrebody in the position shown, the force in the thin stem is measured to be 3000 N. The jet of water has velocity of 30 m/s as it leaves the nozzle.

- [5] (a) Estimate the reading of the pressure gauge in kPa(g). State any assumptions made.
[13] (b) Assume that the pressure gauge reads +400 kPa(g) (Note: This is not the value you should have obtained in part (a)). Determine the force in the bolted joint. Indicate clearly whether the joint is in tension or compression.

[18]

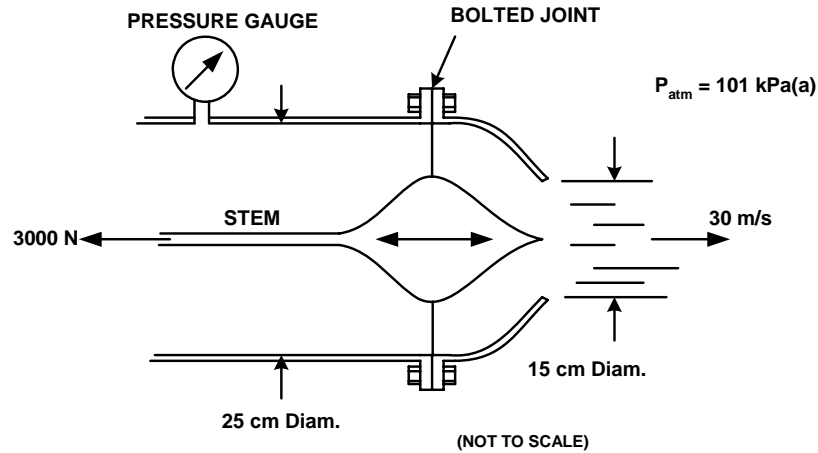

5. The drawing shows schematically a fire fighter spraying water onto a fire. A pump inside the truck provides pressurized water to the hose. The hose has an inside diameter of 10 cm and the outlet of the nozzle has an inside diameter of 5 cm. The hose is made of rubberized canvas and is estimated have a surface roughness of 1 mm on the inside surface.

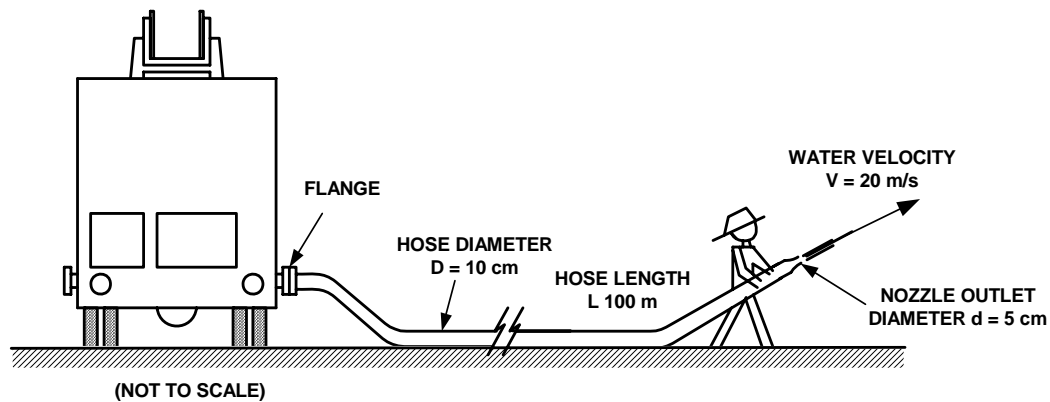

Co

consider initially the case where 100 m of hose is being used.

- [7] (a) Determine the gauge pressure in kPa(g) that the water must have at the flange at the truck to give the fireman a stream of water at the nozzle outlet that has a velocity of 20 m/s. Neglect minor (local) sources of losses. Also neglect any differences in elevation along the length of the hose. The water has a viscosity $\mu = 1.3 \times 10^{-3}$ Ns/m².
- [5] (b) The fire is being fought on a winter day and the ground is covered by ice. As a result, there is essentially no friction between the outside of the hose and the ground. The fireman resists all fluid dynamic forces that occur at the nozzle. However, he does not exert any forces on the hose itself. Estimate the tension force that will be present at the flanged joint where the hose is connected to the truck.

The fire is large and eventually the fireman needs to connect another 100 m of the same kind of hose to reach another part of the fire. The total length is thus 200 m of hose of 10 cm inside diameter.

- [7] (c) The pump at the truck still delivers the same pressure at the flange as calculated in part (a). What is the new velocity at the outlet of the nozzle under these conditions? Assume initially that the same value of friction factor applies as in the earlier calculations.
- [3] (d) Was the assumption of unchanged friction factor reasonable in part (c)? Support your answer quantitatively.

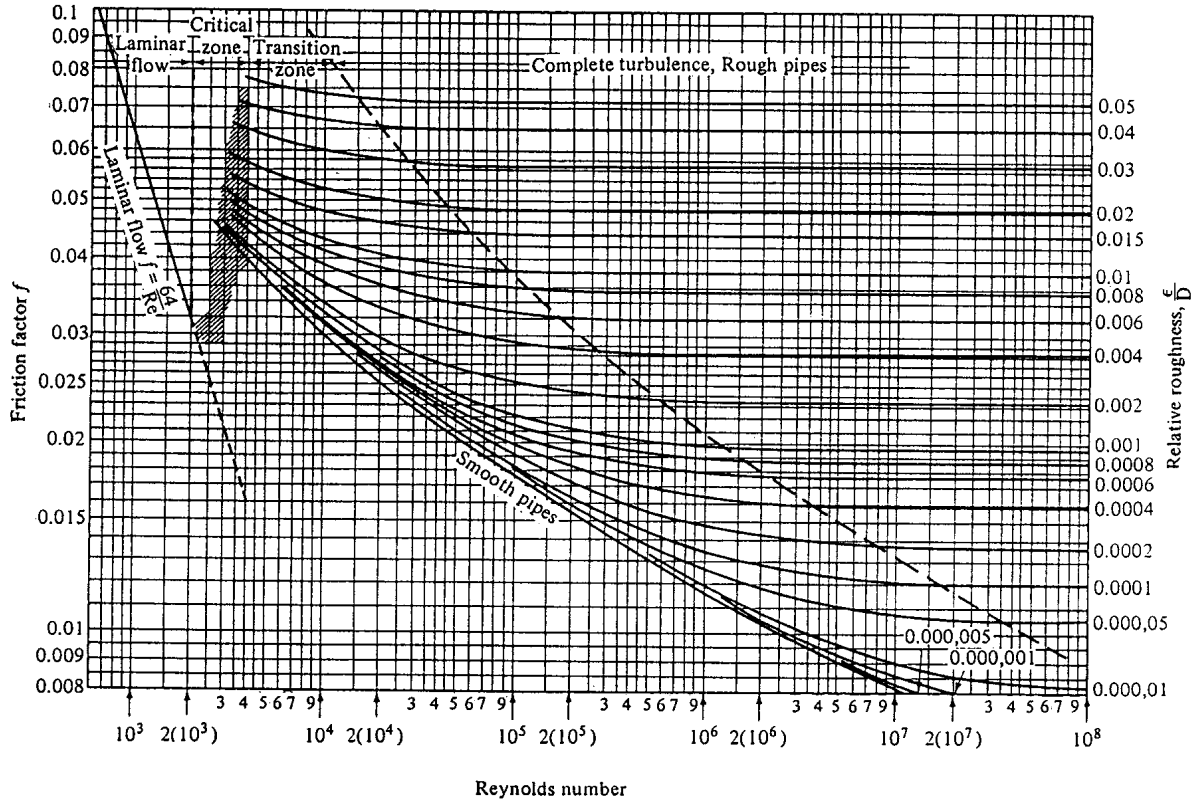

$$f = \frac{h_f}{\frac{LV^2}{D2g}}$$

Reynolds number:

$$Re = \frac{\rho VD}{\mu} = \frac{VD}{\nu}$$