

This is a reproduction of the exam questions from April 2004.

To save paper, this document has been reformatted to omit the blank space where answers could be worked out. The two pages of reference material that were included in the exam have also been omitted here.

Try doing these questions in 3 hours, using only a calculator, ruler, and the two pages of reference formulae and constants to aid you. Answers to the multiple choice part are on the last page.

Do both Part A (Multiple Choice) and Part B (Problems) of this exam.

In Part A, do all 20 multiple choice questions.

In Part B, attempt any 3 of the 4 problems.

The maximum number of marks in Part A is 60, and in Part B is 42.

The maximum mark that may be earned for the exam overall is 100.

PART A (60 marks)

This part consists of 20 multiple choice questions of equal weight. Each question is worth 3 marks. No marks will be deducted for incorrect answers. For each question, one and only one of the five proposed answers is correct.

Indicate your choice by marking the correct box on the answer sheet for Part A, which is page 11 (coloured sheet). Only your choice of answer recorded on the answer sheet will be graded. We recommend that you use pencil to fill in the boxes. If you need to make a change, erase your old answer. Your rough work and calculations for this part will not be considered. You may use the blank pages opposite the questions for these.

1. A charge $q_1 = 4q$ is at $x = 0$, and charge $q_2 = q$ is at $x = R$. The electric field will be equal to zero at
- (a). $x = R/3$
 - (b). $x = 2R/3$
 - (c). $x = -R/3$
 - (d). $x = 2R$
 - (e). nowhere on the x -axis

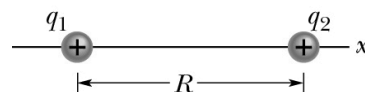

2. A uniformly charged ball of total charge q and radius a is surrounded by a hollow shell of radius b with charge $-q$. The field inside, E_i , at a distance $a < r_1 < b$ from the centre of the sphere, and the field outside, E_o , at a distance $r_2 > b$ are given by:
- (a). $E_i = q / (4\pi \epsilon_0 r_1^2)$, $E_o = 2q / (4\pi \epsilon_0 r_2^2)$
 - (b). $E_i = 0$, $E_o = 0$
 - (c). $E_i = q / (4\pi \epsilon_0 r_1^2)$, $E_o = 0$
 - (d). $E_i = 0$, $E_o = 2q / (4\pi \epsilon_0 r_2^2)$
 - (e). $E_i = q / (4\pi \epsilon_0 r_1^2)$, $E_o = -q / (4\pi \epsilon_0 r_2^2)$

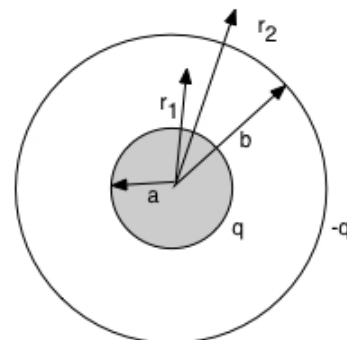

Be sure that you are recording your answers in the boxes on the answer sheet on page 11.

3. Twelve charges, each of $+0.5 \text{ nC}$, are placed at random on a circle of radius 18 cm . The electric potential $V(0)$ [take $V(\infty) = 0$] at the centre of the circle is
- -300 V
 - 300 V
 - unknown, since you need to know where the charges are on the circle
 - 0 V
 - 1670 V

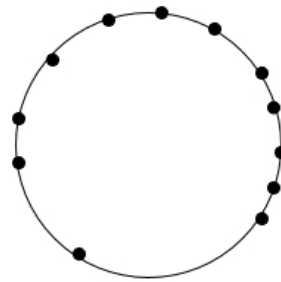

4. The figure shows the potential $V(x)$ as a function of position x . Consider the electric field in the three regions A, B, C. Rank the three regions according to the magnitude of the x -component of the electric field within them, greatest first.
- C, B, A
 - B, A, C
 - A, B, C
 - A, C, B
 - B, C, A

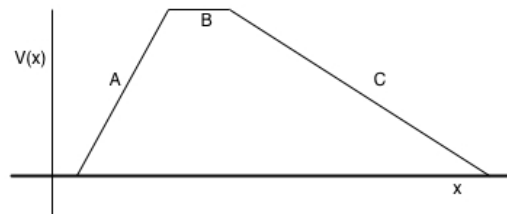

5. A capacitor C_1 has a potential difference V_1 . It is then connected to a second capacitor C_2 , so that the charge will be shared. Is the final total energy U_f of the system
- less than the initial energy U_i , only if $C_1 > C_2$?
 - less than the initial energy U_i , only if $C_1 < C_2$?
 - equal to the initial energy U_i ?
 - always greater than the initial energy U_i ?
 - always less than the initial energy U_i ?

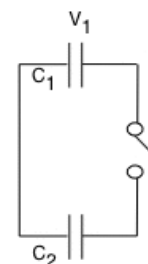

6. A 2.5 m long copper wire (resistivity $\rho = 1.7 \times 10^{-8} \Omega \text{ m}$) has a circular cross section. A current of 1.3 A flows through it when the potential difference between the ends is $42 \times 10^{-3} \text{ V}$. What is the radius of the wire?
- 0.65 mm
 - 1.2 mm
 - 2.1 mm
 - 1.5 mm
 - 0.34 mm

7. In the circuit shown, the capacitor is initially uncharged, and the switch is closed at time $t = 0 \text{ s}$. What is the potential across the capacitor at time $t = 2.5 \mu\text{s}$?
- 35 V
 - 22 V
 - 14 V
 - 8.3 V
 - 2.2 V

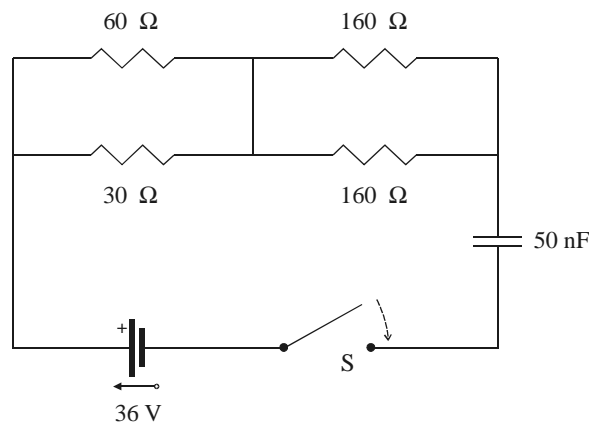

Be sure that you are recording your answers in the boxes on the answer sheet on page 11.

8. A proton has velocity $\mathbf{v} = \mathbf{k} 0.25 \text{ m s}^{-1}$ and is subject to a magnetic field $\mathbf{B} = \mathbf{j} 0.36 \text{ Tesla}$. The resulting force on the proton is
- $-\mathbf{i} 0.090 \text{ newton}$
 - $-\mathbf{i} 1.4 \times 10^{-20} \text{ newton}$
 - $-\mathbf{k} 1.4 \times 10^{-20} \text{ newton}$
 - $\mathbf{i} 0.090 \text{ newton}$
 - $\mathbf{i} 1.4 \times 10^{-20} \text{ newton}$

9. A solenoid is constructed by wrapping 200 turns of wire on a cylindrical support of length 2.00 cm. In order to generate a magnetic field of 30.0 milliTesla, what current is required?
- 0.760 ampere
 - 119 amperes
 - 30.0 amperes
 - 7.50 amperes
 - 2.39 amperes

10. A bar magnet is moved at constant speed from left to right through a closed loop, as shown in the adjacent drawing. At time t_1 the magnet is exactly half-way through the loop. Which one of the five plots below correctly illustrates the induced current around the loop as a function of time? (Take positive current to be clockwise when the loop is viewed from the left).

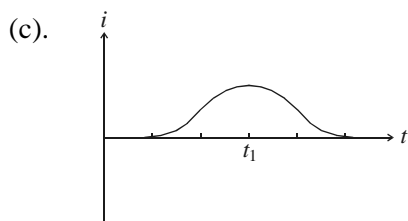
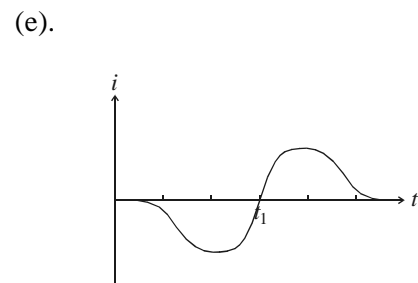
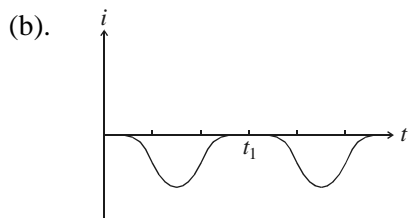
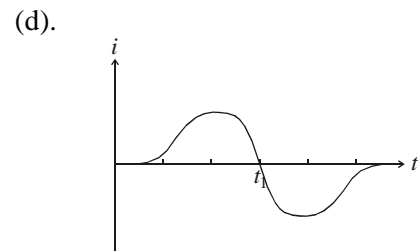
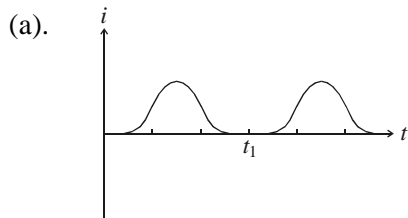
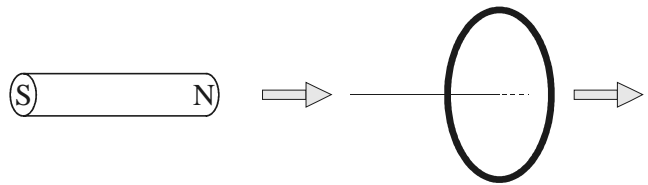

11. One of the following combinations of units reduces to being dimensionless. Which is it?
- $\text{H } \Omega^{-1}$
 - eV m^{-3}
 - $\Omega^2 \text{ F H}^{-1}$
 - $\Omega \text{ F H}$
 - $\Omega \text{ F}$

12. Three different materials are placed in a uniform magnetic field \mathbf{B}_0 as shown in the drawing below. The magnetic fields \mathbf{B}_M due to the magnetization of the materials are as shown by the arrows. Based on this, which one of the following is possible ?
- Sample 1 is ferromagnetic, sample 2 is paramagnetic, sample 3 is diamagnetic
 - Sample 1 is ferromagnetic, sample 2 is diamagnetic, sample 3 is paramagnetic
 - Sample 1 is diamagnetic, sample 2 is paramagnetic, sample 3 is ferromagnetic
 - Sample 1 is paramagnetic, sample 2 is ferromagnetic, sample 3 is diamagnetic
 - Sample 1 is paramagnetic, sample 2 is diamagnetic, sample 3 is ferromagnetic

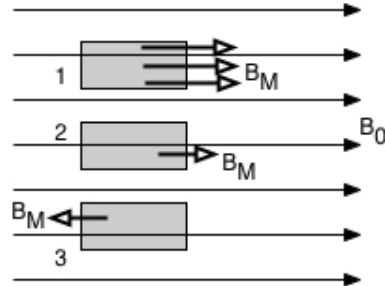

13. What is the capacitance of an oscillating LC circuit if the maximum charge on the capacitor is $1.50 \mu\text{C}$ and the total energy is $200 \mu\text{J}$?
- 5.63 pF
 - $5.56 \mu\text{F}$
 - 5.63 nF
 - 11.12 nF
 - $11.12 \mu\text{F}$
14. An ac generator has an emf $\mathcal{E} = \mathcal{E}_m \sin(\omega_d t)$, where $\mathcal{E}_m = 30.0$ volts and $\omega_d = 350$ rad/s. The generator is connected in series with an inductor $L = 230 \text{ mH}$, a capacitor $C = 15.0 \mu\text{F}$, and a resistor $R = 200 \Omega$. What is the phase angle relation between the current through the circuit and the voltage of the generator?
- The current leads the voltage by 28.8° .
 - The current lags the voltage by 28.8° .
 - The current and voltage are in phase.
 - The current leads the voltage by 21.9° .
 - The current lags the voltage by 21.9° .
15. An ideal transformer has 500 primary turns and 10 secondary turns. If V_p is 120 volts (rms) and the secondary circuit has a resistive load of 15Ω , what is the current in the primary circuit ?
- 0.16 A (rms)
 - 8.0 A (rms)
 - 40 A (rms)
 - 3.2 mA (rms)
 - 0.16 mA (rms)
16. An electromagnetic plane wave is travelling in the $+y$ direction in vacuum. The peak amplitude of the electric field is 340 V/m . Which one of the following statements is true?
- The magnetic field has peak amplitude 102 GT and is in the x - z plane
 - The magnetic field has peak amplitude 240 T and is in the x - z plane
 - The magnetic and electric fields are both in the x - z plane and parallel to each other
 - The magnetic field has peak amplitude $1.13 \mu\text{T}$ and is in the x - z plane
 - The magnetic field is in the y -direction and the electric field is in the x - z plane

17. Three polarizers are mounted in an assembly. The second has its transmission axis at 20° with respect to that of the first. The third has its transmission axis at 20° with respect to that of the second. What fraction of the intensity of incident natural light does the assembly transmit ?
- 0.883
 - 0.442
 - 0.780
 - 0.470
 - 0.390
18. An ultrafast laser is capable of producing a pulse of light only 1 femtosecond (1×10^{-15} s) in duration. What is the length of such a light pulse in air, and the length in water ? (note: $n = 1.33$ for water).
- 300 nm in air, 225 nm in water
 - 300 nm in air, 399 nm in water
 - 260 nm in air, 300 nm in water
 - 225 nm in air, 260 nm in water
 - 300 nm in air, 260 nm in water
19. A beam of light travelling through glass hits a glass-air surface with an angle of incidence of 45° . If the glass has a refractive index of 1.40, the angle of refraction is
- 45°
 - 81.9°
 - 30.3°
 - the beam is totally internally reflected
 - 63°
20. Consider a thin diverging lens with focal length -30.0 cm. An object is placed 2.00 m in front of the lens. Which one of the following is true ?
- the image is 26.1 cm behind the lens, is real, and inverted
 - the image is 26.1 cm in front of the lens, is real, and inverted
 - the image is 26.1 cm in front of the lens, is virtual, and inverted
 - the image is 26.1 cm behind the lens, is real, and upright
 - the image is 26.1 cm in front of the lens, is virtual, and upright

Make sure that you have put your name, student number, and tutorial section at the top of the answer sheet on page 11 for the portion of the exam you've just completed (Part A - Multiple Choice), and go on to Part B which starts on page 15.

.....

.....

PART B (42 marks)

Attempt any three problems and give complete solutions in the space provided in this book.

*This part consists of four problems of equal value (14 marks each). **Attempt any three and only three of these problems.** For this part of exam, your detailed solutions including starting assumptions or physical laws, physical or logical reasoning, and mathematical calculations will be examined and evaluated. They are as important as your actual results. Make sure you give clear and adequate, but short, explanations.*

Problem 1

The diagram shows a schematic of a TV tube. Electrons are accelerated from the cathode at the rear of the tube (on the left side of the drawing) which is at -10 kV , rightwards through a hole in the anode which is at 0 V , and are then deflected by the plates. The potential difference between the plates is 1500 V , their separation is 1.2 cm , and the plates are 5 cm long.

- What is the speed of the electrons as they pass through the anode ?
- How long do the electrons take to pass between the plates ?
- What is the field between the plates ?
- What is the vertical acceleration of the electrons between the plates ?

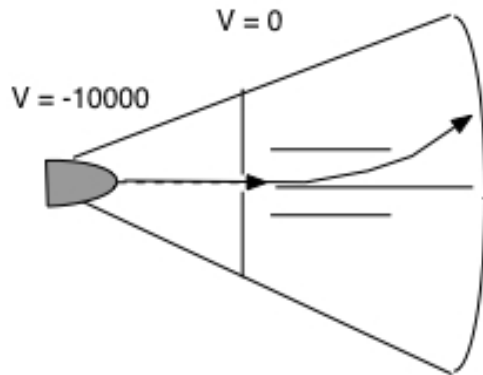

Problem 2

(To assist in grading this problem, please circle your numerical answers).

- Find the value of each of the three currents i_1 , i_2 , and i_3 that flow in each branch of the circuit shown. Do NOT redefine the direction of any given current. Use the directions indicated in the diagram; any negative solution is then interpreted as physically flowing in the opposite direction.
- Find the potential difference $V_b - V_a$.
- What is the power output of battery B_1 ? Is it being charged or discharged ?
What is the power output of battery B_2 ? Is it being charged or discharged ?
What is the power output of battery B_3 ? Is it being charged or discharged ?
- Show that the net power output of all three batteries (taking due regard to sign) is equal to the total power dissipated in all three resistors.

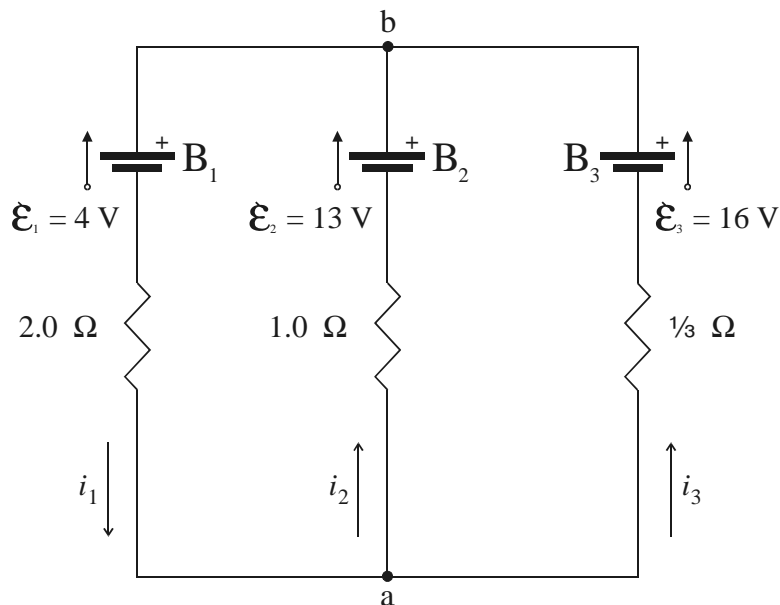

Problem 3

A cylindrical conductor of radius R carries a current i which is non-uniformly distributed across its cross section. The current density as a function of distance r from the centre of the conductor is

$$J(r) = C + Sr \quad (\text{for } 0 \leq r \leq R),$$

where C and S are constants.

- Indicate on the illustration below the orientation of the magnetic field lines which result from the current.
- Using Ampere's Law, derive an expression for the magnitude of the magnetic field external to the conductor, i.e. for $r \geq R$, in terms of the total current i .
- Using Ampere's Law, derive an expression for the magnitude of the magnetic field inside the conductor, i.e. for $r \leq R$, in terms of C and S .
- Numerically evaluate your expression from part (c) for $C = 4.00 \times 10^6 \text{ A m}^{-2}$, $S = 1.80 \times 10^{10} \text{ A m}^{-3}$, $R = 1.00 \text{ mm}$, $r = 0.500 \text{ mm}$.

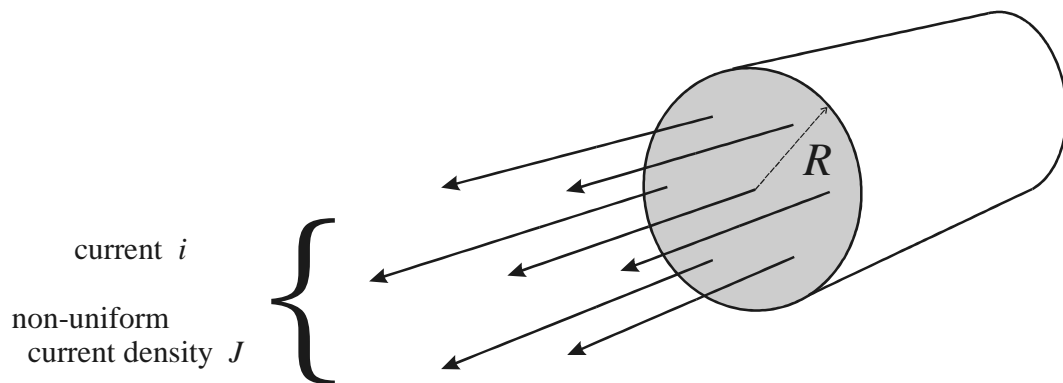

Problem 4

In the figure $R = 8.0 \Omega$, $C = 5.0 \mu\text{F}$, and $L = 30.0 \text{ mH}$. The generator provides a sinusoidal voltage of 100.0 V (rms) and frequency 1.00 kHz .

- Calculate the rms current.
- Find the rms voltages V_{ab} , V_{bc} , V_{cd} , V_{bd} , V_{ad} .
- At what average rate is energy dissipated by each of the three circuit elements?

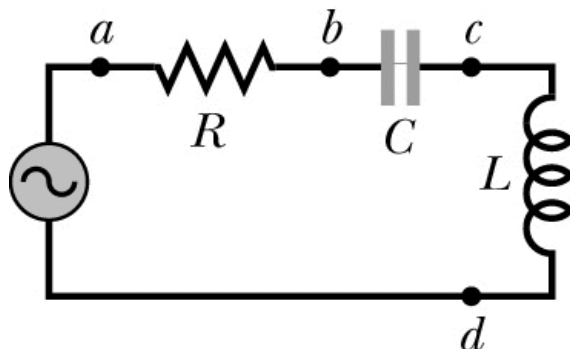

- | | a | b | c | d | e |
|----|--------------------------|-------------------------------------|-------------------------------------|-------------------------------------|-------------------------------------|
| 1. | <input type="checkbox"/> | <input checked="" type="checkbox"/> | <input type="checkbox"/> | <input type="checkbox"/> | <input type="checkbox"/> |
| 2. | <input type="checkbox"/> | <input type="checkbox"/> | <input checked="" type="checkbox"/> | <input type="checkbox"/> | <input type="checkbox"/> |
| 3. | <input type="checkbox"/> | <input checked="" type="checkbox"/> | <input type="checkbox"/> | <input type="checkbox"/> | <input type="checkbox"/> |
| 4. | <input type="checkbox"/> | <input type="checkbox"/> | <input type="checkbox"/> | <input checked="" type="checkbox"/> | <input type="checkbox"/> |
| 5. | <input type="checkbox"/> | <input type="checkbox"/> | <input type="checkbox"/> | <input type="checkbox"/> | <input checked="" type="checkbox"/> |

- | | a | b | c | d | e |
|-----|-------------------------------------|-------------------------------------|-------------------------------------|--------------------------|-------------------------------------|
| 6. | <input checked="" type="checkbox"/> | <input type="checkbox"/> | <input type="checkbox"/> | <input type="checkbox"/> | <input type="checkbox"/> |
| 7. | <input type="checkbox"/> | <input type="checkbox"/> | <input checked="" type="checkbox"/> | <input type="checkbox"/> | <input type="checkbox"/> |
| 8. | <input type="checkbox"/> | <input checked="" type="checkbox"/> | <input type="checkbox"/> | <input type="checkbox"/> | <input type="checkbox"/> |
| 9. | <input type="checkbox"/> | <input type="checkbox"/> | <input type="checkbox"/> | <input type="checkbox"/> | <input checked="" type="checkbox"/> |
| 10. | <input type="checkbox"/> | <input type="checkbox"/> | <input type="checkbox"/> | <input type="checkbox"/> | <input checked="" type="checkbox"/> |

- | | a | b | c | d | e |
|-----|-------------------------------------|--------------------------|-------------------------------------|-------------------------------------|--------------------------|
| 11. | <input type="checkbox"/> | <input type="checkbox"/> | <input checked="" type="checkbox"/> | <input type="checkbox"/> | <input type="checkbox"/> |
| 12. | <input checked="" type="checkbox"/> | <input type="checkbox"/> | <input type="checkbox"/> | <input type="checkbox"/> | <input type="checkbox"/> |
| 13. | <input type="checkbox"/> | <input type="checkbox"/> | <input checked="" type="checkbox"/> | <input type="checkbox"/> | <input type="checkbox"/> |
| 14. | <input checked="" type="checkbox"/> | <input type="checkbox"/> | <input type="checkbox"/> | <input type="checkbox"/> | <input type="checkbox"/> |
| 15. | <input type="checkbox"/> | <input type="checkbox"/> | <input type="checkbox"/> | <input checked="" type="checkbox"/> | <input type="checkbox"/> |

- | | a | b | c | d | e |
|-----|-------------------------------------|-------------------------------------|--------------------------|-------------------------------------|-------------------------------------|
| 16. | <input type="checkbox"/> | <input type="checkbox"/> | <input type="checkbox"/> | <input checked="" type="checkbox"/> | <input type="checkbox"/> |
| 17. | <input type="checkbox"/> | <input type="checkbox"/> | <input type="checkbox"/> | <input type="checkbox"/> | <input checked="" type="checkbox"/> |
| 18. | <input checked="" type="checkbox"/> | <input type="checkbox"/> | <input type="checkbox"/> | <input type="checkbox"/> | <input type="checkbox"/> |
| 19. | <input type="checkbox"/> | <input checked="" type="checkbox"/> | <input type="checkbox"/> | <input type="checkbox"/> | <input type="checkbox"/> |
| 20. | <input type="checkbox"/> | <input type="checkbox"/> | <input type="checkbox"/> | <input type="checkbox"/> | <input checked="" type="checkbox"/> |