

Solutions #2

Dear students,

Below are the solutions to the Problems #2.

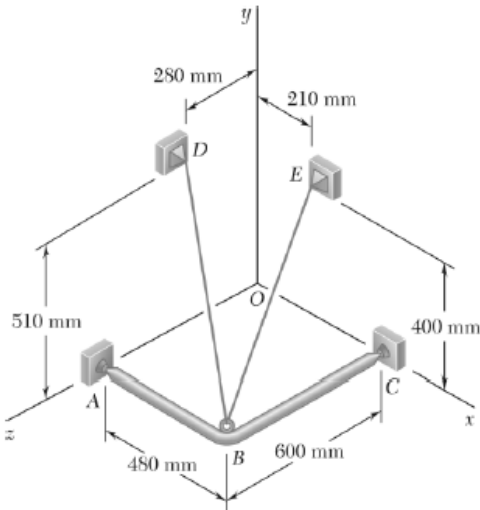

PROBLEM 2.89

A frame ABC is supported in part by cable DBE that passes through a frictionless ring at B . Knowing that the tension in the cable is 385 N , determine the components of the force exerted by the cable on the support at D .

SOLUTION

$$\overline{DB} = (480\text{ mm})\mathbf{i} - (510\text{ mm})\mathbf{j} + (320\text{ mm})\mathbf{k}$$

$$DB = \sqrt{(480\text{ mm})^2 + (510\text{ mm})^2 + (320\text{ mm})^2}$$
$$= 770\text{ mm}$$

$$\mathbf{F} = F\lambda_{DB}$$

$$= F \frac{\overline{DB}}{DB}$$

$$= \frac{385\text{ N}}{770\text{ mm}} [(480\text{ mm})\mathbf{i} - (510\text{ mm})\mathbf{j} + (320\text{ mm})\mathbf{k}]$$

$$= (240\text{ N})\mathbf{i} - (255\text{ N})\mathbf{j} + (160\text{ N})\mathbf{k}$$

$$F_x = +240\text{ N}, \quad F_y = -255\text{ N}, \quad F_z = +160.0\text{ N} \quad \blacktriangleleft$$

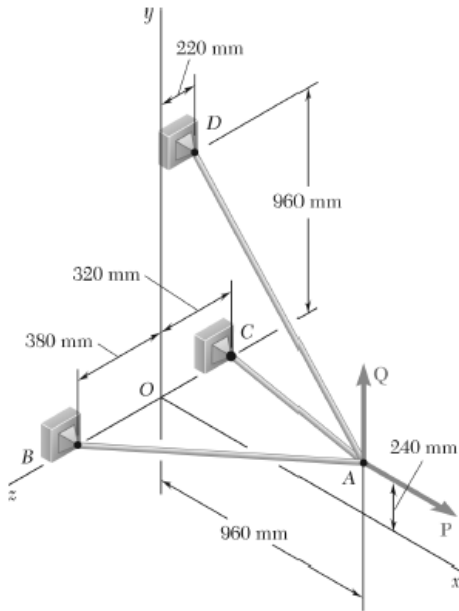

PROBLEM 2.107

Three cables are connected at A, where the forces \mathbf{P} and \mathbf{Q} are applied as shown. Knowing that $Q = 0$, find the value of P for which the tension in cable AD is 305 N.

SOLUTION

$$\Sigma \mathbf{F}_A = 0: \quad \mathbf{T}_{AB} + \mathbf{T}_{AC} + \mathbf{T}_{AD} + \mathbf{P} = 0 \quad \text{where} \quad \mathbf{P} = P\mathbf{i}$$

$$\overline{AB} = -(960 \text{ mm})\mathbf{i} - (240 \text{ mm})\mathbf{j} + (380 \text{ mm})\mathbf{k} \quad AB = 1060 \text{ mm}$$

$$\overline{AC} = -(960 \text{ mm})\mathbf{i} - (240 \text{ mm})\mathbf{j} - (320 \text{ mm})\mathbf{k} \quad AC = 1040 \text{ mm}$$

$$\overline{AD} = -(960 \text{ mm})\mathbf{i} + (720 \text{ mm})\mathbf{j} - (220 \text{ mm})\mathbf{k} \quad AD = 1220 \text{ mm}$$

$$\mathbf{T}_{AB} = T_{AB} \lambda_{AB} = T_{AB} \frac{\overline{AB}}{AB} = T_{AB} \left(-\frac{48}{53}\mathbf{i} - \frac{12}{53}\mathbf{j} + \frac{19}{53}\mathbf{k} \right)$$

$$\mathbf{T}_{AC} = T_{AC} \lambda_{AC} = T_{AC} \frac{\overline{AC}}{AC} = T_{AC} \left(-\frac{12}{13}\mathbf{i} - \frac{3}{13}\mathbf{j} - \frac{4}{13}\mathbf{k} \right)$$

$$\begin{aligned} \mathbf{T}_{AD} &= T_{AD} \lambda_{AD} = \frac{305 \text{ N}}{1220 \text{ mm}} [(-960 \text{ mm})\mathbf{i} + (720 \text{ mm})\mathbf{j} - (220 \text{ mm})\mathbf{k}] \\ &= -(240 \text{ N})\mathbf{i} + (180 \text{ N})\mathbf{j} - (55 \text{ N})\mathbf{k} \end{aligned}$$

Substituting into $\Sigma \mathbf{F}_A = 0$, factoring \mathbf{i} , \mathbf{j} , \mathbf{k} , and setting each coefficient equal to ϕ gives:

$$\mathbf{i}: \quad P = \frac{48}{53}T_{AB} + \frac{12}{13}T_{AC} + 240 \text{ N} \quad (1)$$

$$\mathbf{j}: \quad \frac{12}{53}T_{AB} + \frac{3}{13}T_{AC} = 180 \text{ N} \quad (2)$$

$$\mathbf{k}: \quad \frac{19}{53}T_{AB} - \frac{4}{13}T_{AC} = 55 \text{ N} \quad (3)$$

Solving the system of linear equations using conventional algorithms gives:

$$T_{AB} = 446.71 \text{ N}$$

$$T_{AC} = 341.71 \text{ N}$$

$$P = 960 \text{ N} \quad \blacktriangleleft$$

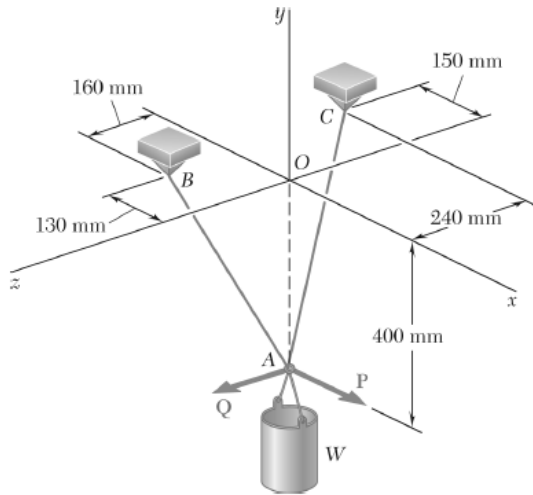

PROBLEM 2.123

A container of weight W is suspended from ring A . Cable BAC passes through the ring and is attached to fixed supports at B and C . Two forces $\mathbf{P} = P\mathbf{i}$ and $\mathbf{Q} = Q\mathbf{k}$ are applied to the ring to maintain the container in the position shown. Knowing that $W = 376 \text{ N}$, determine P and Q . (*Hint:* The tension is the same in both portions of cable BAC .)

SOLUTION

$$\begin{aligned} \mathbf{T}_{AB} &= T\lambda_{AB} \\ &= T \frac{\overline{AB}}{AB} \\ &= T \frac{(-130 \text{ mm})\mathbf{i} + (400 \text{ mm})\mathbf{j} + (160 \text{ mm})\mathbf{k}}{450 \text{ mm}} \\ &= T \left(-\frac{13}{45}\mathbf{i} + \frac{40}{45}\mathbf{j} + \frac{16}{45}\mathbf{k} \right) \end{aligned}$$

$$\begin{aligned} \mathbf{T}_{AC} &= T\lambda_{AC} \\ &= T \frac{\overline{AC}}{AC} \\ &= T \frac{(-150 \text{ mm})\mathbf{i} + (400 \text{ mm})\mathbf{j} + (-240 \text{ mm})\mathbf{k}}{490 \text{ mm}} \\ &= T \left(-\frac{15}{49}\mathbf{i} + \frac{40}{49}\mathbf{j} - \frac{24}{49}\mathbf{k} \right) \end{aligned}$$

$$\Sigma F = 0: \quad \mathbf{T}_{AB} + \mathbf{T}_{AC} + \mathbf{Q} + \mathbf{P} + \mathbf{W} = 0$$

Setting coefficients of **i**, **j**, **k** equal to zero:

$$\mathbf{i}: \quad -\frac{13}{45}T - \frac{15}{49}T + P = 0 \qquad 0.59501T = P \qquad (1)$$

$$\mathbf{j}: \quad +\frac{40}{45}T + \frac{40}{49}T - W = 0 \qquad 1.70521T = W \qquad (2)$$

$$\mathbf{k}: \quad +\frac{16}{45}T - \frac{24}{49}T + Q = 0 \qquad 0.134240T = Q \qquad (3)$$

Data:

$$W = 376 \text{ N} \quad 1.70521T = 376 \text{ N} \quad T = 220.50 \text{ N}$$

$$0.59501(220.50 \text{ N}) = P$$

$$P = 131.2 \text{ N} \quad \blacktriangleleft$$

$$0.134240(220.50 \text{ N}) = Q$$

$$Q = 29.6 \text{ N} \quad \blacktriangleleft$$

Free-Body A:

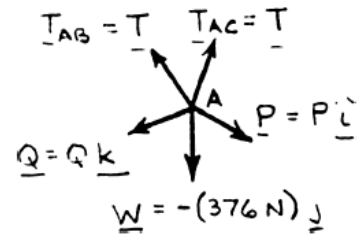

PROBLEM 2.136

Three cables are used to tether a balloon as shown. Determine the vertical force \mathbf{P} exerted by the balloon at A knowing that the tension in cable AC is 444 N.

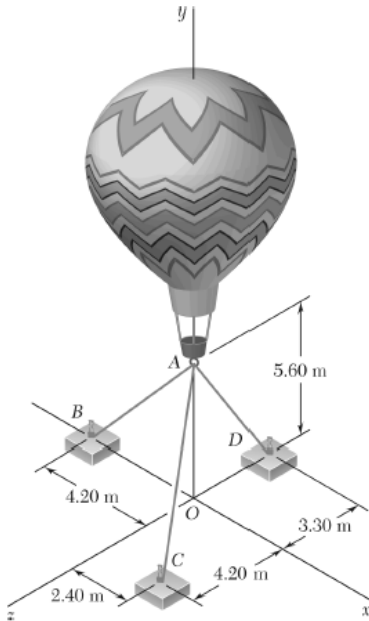

SOLUTION

See Problem 2.101 for the figure and the analysis leading to the linear algebraic Equations (1), (2), and (3) below:

$$-0.6T_{AB} + 0.32432T_{AC} = 0 \quad (1)$$

$$-0.8T_{AB} - 0.75676T_{AC} - 0.86154T_{AD} + P = 0 \quad (2)$$

$$0.56757T_{AC} - 0.50769T_{AD} = 0 \quad (3)$$

Substituting $T_{AC} = 444 \text{ N}$ in Equations (1), (2), and (3) above, and solving the resulting set of equations using conventional algorithms gives

$$T_{AB} = 240 \text{ N}$$

$$T_{AD} = 496.36 \text{ N}$$

$$\mathbf{P} = 956 \text{ N} \uparrow \blacktriangleleft$$

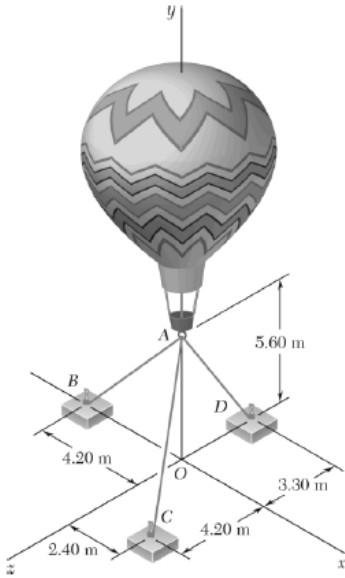

PROBLEM 2.101

Three cables are used to tether a balloon as shown. Determine the vertical force \mathbf{P} exerted by the balloon at A knowing that the tension in cable AD is 481 N.

SOLUTION

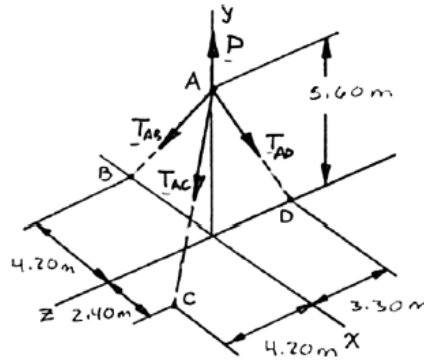

The forces applied at A are:

$$\mathbf{T}_{AB}, \mathbf{T}_{AC}, \mathbf{T}_{AD}, \text{ and } \mathbf{P}$$

where $\mathbf{P} = P\mathbf{j}$. To express the other forces in terms of the unit vectors \mathbf{i} , \mathbf{j} , \mathbf{k} , we write

$$\overline{AB} = -(4.20 \text{ m})\mathbf{i} - (5.60 \text{ m})\mathbf{j} \quad AB = 7.00 \text{ m}$$

$$\overline{AC} = (2.40 \text{ m})\mathbf{i} - (5.60 \text{ m})\mathbf{j} + (4.20 \text{ m})\mathbf{k} \quad AC = 7.40 \text{ m}$$

$$\overline{AD} = -(5.60 \text{ m})\mathbf{j} - (3.30 \text{ m})\mathbf{k} \quad AD = 6.50 \text{ m}$$

and

$$\mathbf{T}_{AB} = T_{AB} \lambda_{AB} = T_{AB} \frac{\overline{AB}}{AB} = (-0.6\mathbf{i} - 0.8\mathbf{j})T_{AB}$$

$$\mathbf{T}_{AC} = T_{AC} \lambda_{AC} = T_{AC} \frac{\overline{AC}}{AC} = (0.32432\mathbf{i} - 0.75676\mathbf{j} + 0.56757\mathbf{k})T_{AC}$$

$$\mathbf{T}_{AD} = T_{AD} \lambda_{AD} = T_{AD} \frac{\overline{AD}}{AD} = (-0.86154\mathbf{j} - 0.50769\mathbf{k})T_{AD}$$

Equilibrium condition: $\Sigma F = 0: \mathbf{T}_{AB} + \mathbf{T}_{AC} + \mathbf{T}_{AD} + P\mathbf{j} = 0$

Substituting the expressions obtained for \mathbf{T}_{AB} , \mathbf{T}_{AC} , and \mathbf{T}_{AD} and factoring \mathbf{i} , \mathbf{j} , and \mathbf{k} :

$$\begin{aligned} &(-0.6T_{AB} + 0.32432T_{AC})\mathbf{i} + (-0.8T_{AB} - 0.75676T_{AC} - 0.86154T_{AD} + P)\mathbf{j} \\ &+ (0.56757T_{AC} - 0.50769T_{AD})\mathbf{k} = 0 \end{aligned}$$

Equating to zero the coefficients of \mathbf{i} , \mathbf{j} , \mathbf{k} :

$$-0.6T_{AB} + 0.32432T_{AC} = 0 \quad (1)$$

$$-0.8T_{AB} - 0.75676T_{AC} - 0.86154T_{AD} + P = 0 \quad (2)$$

$$0.56757T_{AC} - 0.50769T_{AD} = 0 \quad (3)$$

Setting $T_{AD} = 481 \text{ N}$ in (2) and (3), and solving the resulting set of equations gives

$$T_{AC} = 430.26 \text{ N}$$

$$T_{AD} = 232.57 \text{ N}$$

$$\mathbf{P} = 926 \text{ N} \uparrow \blacktriangleleft$$