

Question 1 (45 marks)

A Rankine cycle power plant, illustrated in the figure below, employs water as the working fluid. The flow rate of the working fluid is 440 kg/s and the rate of heat addition at the boiler is 1.5 GW. Steam enters the turbine at 16 MPa and exits at 6 kPa. Liquid water enters the pump at 6 kPa and 30°C. The isentropic efficiency of the turbine is 91% and the isentropic efficiency of the pump is 65%.

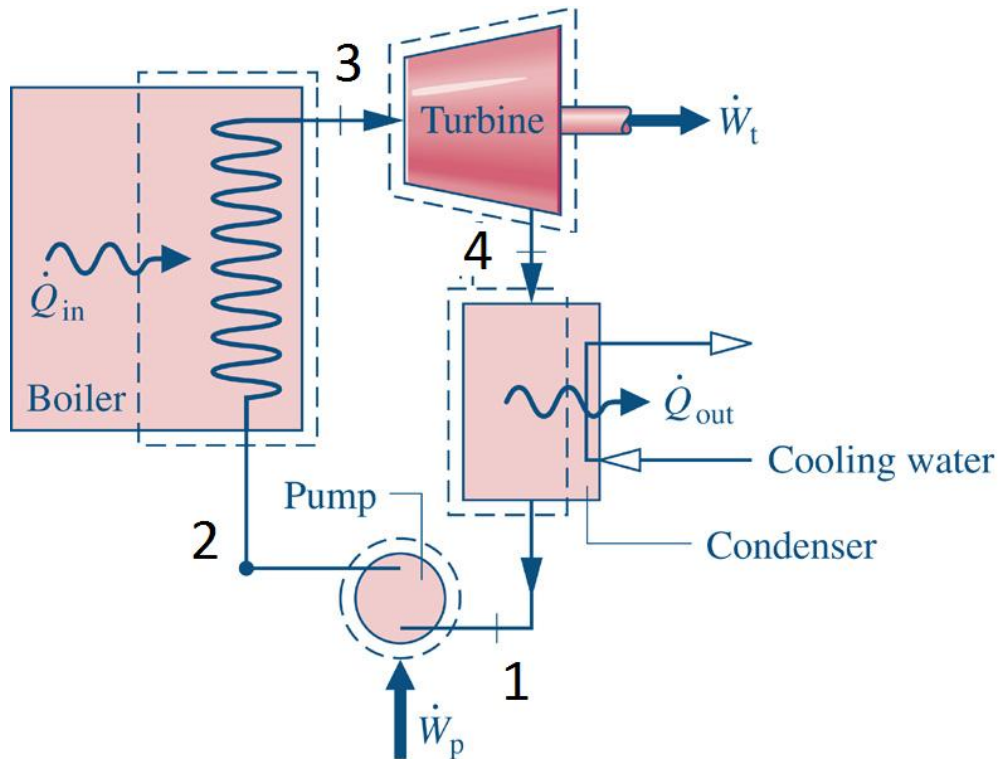

List all assumptions used in your analysis and indicate all sources of data (e.g. Table A-1). Marks will be deducted if you neglect to adequately justify the form of the 1st law energy balances used to represent each process.

Perform the following:

- Indicate the state points of the cycle on a T-s diagram. Clearly indicate the 6 kPa and 16 MPa isobars (lines of constant pressure). You must follow the state point numbering scheme utilized in the above figure.
- Determine the saturation temperatures at the boiler pressure and at the condenser pressure. Indicate these on the T-s diagram.
- Calculate the power input to the pump in MW.
- Calculate the specific enthalpy at the outlet of the pump (state 2).
- Determine the temperature of the steam exiting the boiler (state 3).
- Calculate the steam quality at the turbine exit (state 4).
- Calculate the power output from the turbine in MW.

- h) Calculate the rate of heat rejection from the condenser in MW.
- i) Calculate the back work ratio.
- j) Calculate the thermal efficiency of the cycle.
- k) Is the steam quality at the turbine exit (state 4) sufficiently high? Suggest one design change that could be made to the cycle to produce a higher steam quality. Explain why this design change will have an impact. (Note: Use no more than 3 sentences and/or a T-s diagram to answer this question.)

Question 2 (30 marks)

A combined Brayton and Rankine cycle power plant is illustrated in the figure below. The Brayton cycle portion of the power plant can be treated with an air-standard analysis. Air enters the compressor (state 1) at 300 K and 100 kPa and is compressed to 1.1 MPa by the compressor which has an isentropic efficiency of 90%. The mass flow rate of the air through the cycle is 100 kg/s. The rate of heat addition at the combustor is 75 MW (\dot{Q}_{in}). The air is then expanded to 100 kPa (state 4) by the turbine, which has an isentropic efficiency of 92%. Finally the air is cooled to 420 K by the heat exchanger between the gas and vapour cycles before it is exhausted to the environment.

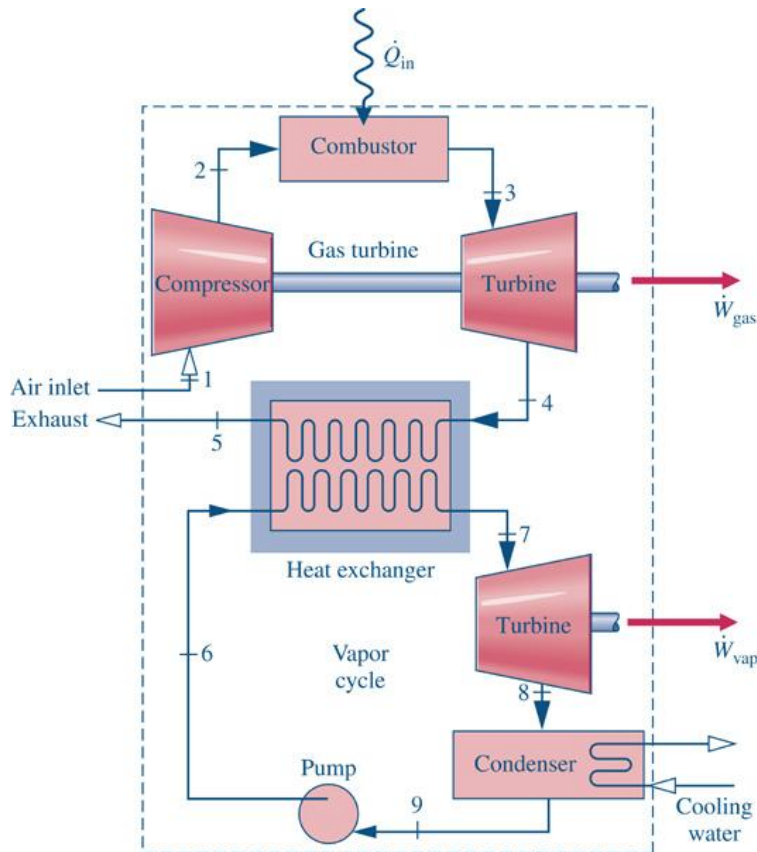

List all assumptions used in your analysis and indicate all sources of data (e.g. Table A-1). Marks will be deducted if you neglect to adequately justify the form of the 1st law energy balances used to represent each process.

Perform the following:

- Indicate state points 1 through 5 on a T-s diagram. You must follow the state point numbering scheme utilized in the above figure.
- Calculate the power input to the compressor in MW.
- Determine the temperature of the air exiting the compressor (state 2).
- Determine the temperature of the air entering the turbine (state 3).
- Calculate power output from the Brayton cycle's turbine (\dot{W}_{gas}) in MW.
- Determine the temperature of the air entering the heat exchanger that couples the Brayton and Rankine cycles (state 4).
- Calculate the rate of heat transfer from the Brayton cycle to the Rankine cycle through the heat exchanger in MW.

Question 3 (15 marks)

A wine cabinet is cooled by the vapour compression refrigeration system illustrated in the figure below. The system has a condenser pressure of 10 bar and an evaporator pressure of 4 bar and employs R134a as the working fluid. The working fluid has a specific volume of $0.0504 \text{ m}^3/\text{kg}$ at the inlet to the compressor (state 1) and a temperature of 38°C at the outlet of the condenser (state 3).

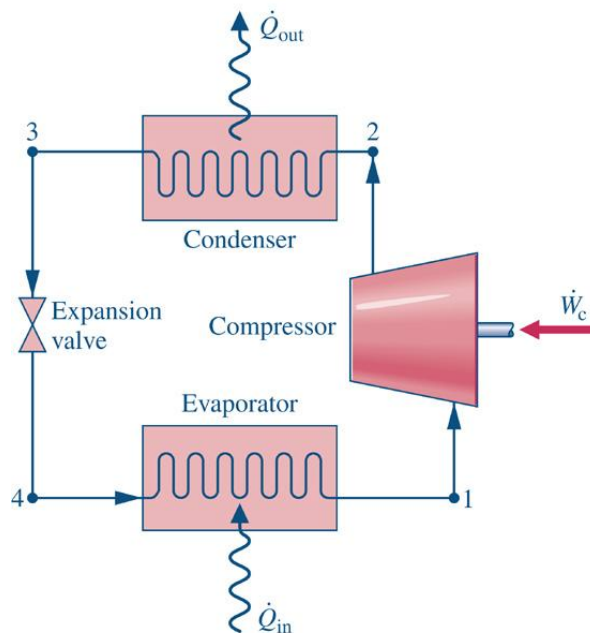

List all assumptions used in your analysis and indicate all sources of data (e.g. Table A-1). Marks will be deducted if you neglect to adequately justify the form of the 1st law energy balances used to represent each process.

Perform the following:

- a) Indicate the state points of the cycle on a T-s diagram. Clearly indicate the 4 bar and 10 bar isobars (lines of constant pressure). You must follow the state point numbering scheme utilized in the above figure.
- b) What is the coldest temperature that could possibly be maintained in the wine cabinet?
- c) Calculate the specific cooling rate at the evaporator (\dot{Q}_in / \dot{m}) in kJ/kg.

Question 4 (10 marks)

- a) An uncooked pizza is placed on an oven rack underneath a broiler element that is at a temperature of 500°C. What is the dominant mode of heat transfer between the broiler element and the pizza?
- b) Once cooked, the hot pizza is placed on a cold plate. After a period of time the plate has been warmed by the pizza. What was the dominant mode of heat transfer between the pizza and the plate?
- c) The walls of the pizza oven are insulated with a material having a constant thermal conductivity of 0.04 W/mK. The conductive heat flux through the oven walls is 400 W/m². What thickness of insulation is required to result in a 200°C temperature difference across the insulation layer? Assume one-dimensional and steady-state conduction heat transfer.