

# Chapter 5—The Laws of Motion

## MULTIPLE CHOICE

1. In the figure, if the tension in string 1 is 34 N and the tension in string 2 is 24 N, what is the mass of the object shown?

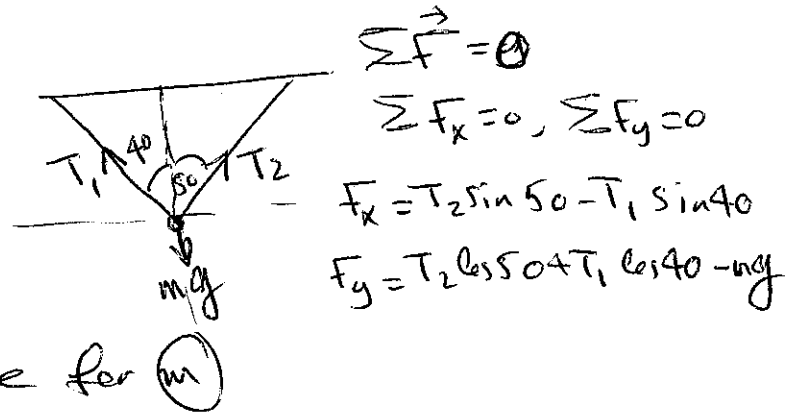
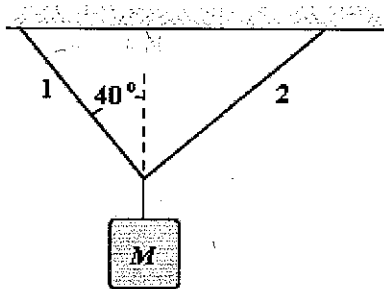

- a. 7.3 kg
- b. 5.5 kg
- c. 1.8 kg
- d. 3.7 kg
- e. 4.5 kg

ANS: D

PTS: 2

DIF: Average

2. If  $M = 2.0$  kg, what is the tension in string 1?

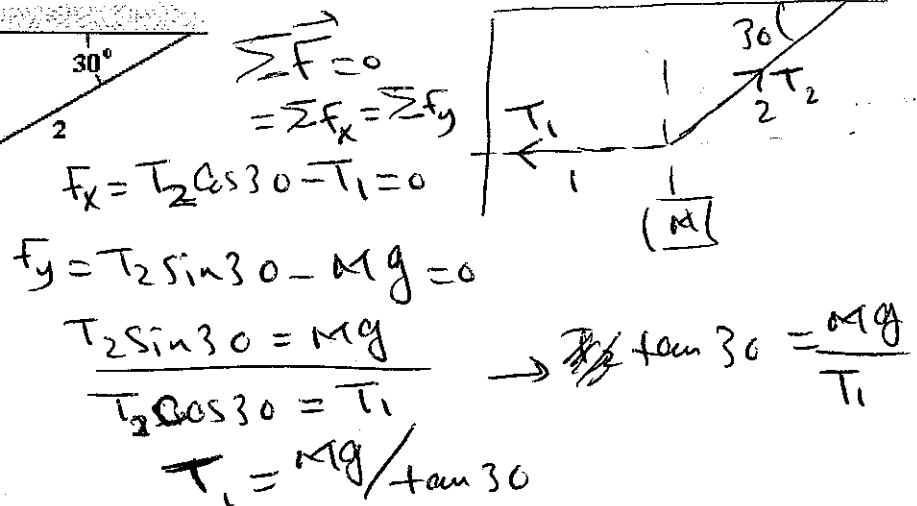
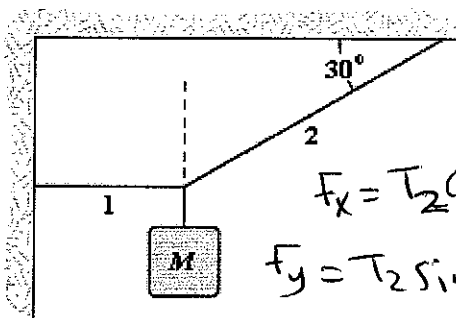

- a. 1.2 N
- b. 11 N
- c. 34 N
- d. 3.5 N
- e. 40 N

ANS: C

PTS: 2

DIF: Average

3. If  $M = 6.0$  kg, what is the tension in string 1?

Similar to #2

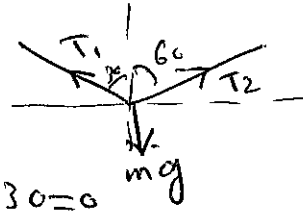
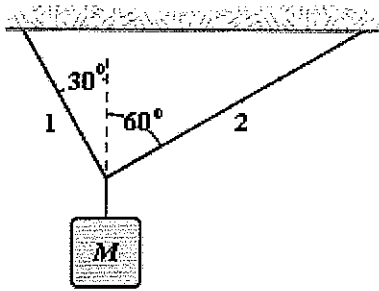

$$T_2 \sin 60 - T_1 \sin 30 = 0$$

$$T_2 \cos 60 + T_1 \cos 30 = mg$$

- a. 39 N
- b. 34 N
- c. 29 N
- d. 44 N
- e. 51 N

ANS: E

PTS: 3

DIF: Challenging

4. If  $M = 1.1$  kg, what is the tension in string 1?

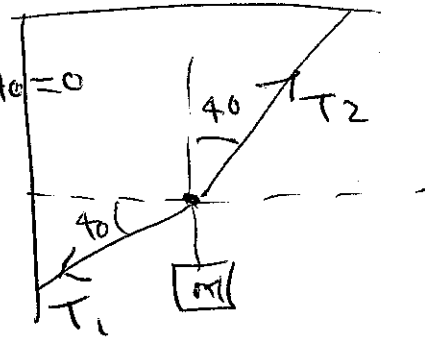
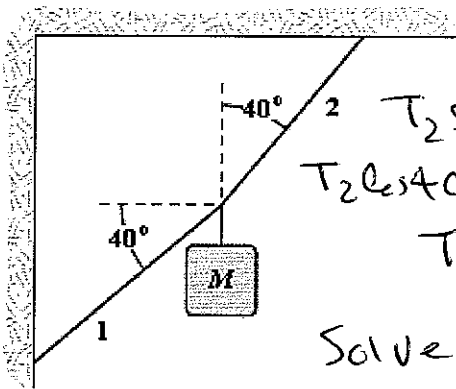

$$T_2 \sin 40 - T_1 \cos 40 = 0$$

$$T_2 \cos 40 - mg - T_1 \sin 40 = 0$$

Solve for  $T_1$

- a. 54 N
- b. 47 N
- c. 40 N
- d. 62 N
- e. 57 N

ANS: C

PTS: 3

DIF: Challenging

5. An object of unknown weight is suspended as shown. The tension in rope 1 is 25 lb, and the tension in rope 2 is 31 lb. What is the weight of the suspended object?

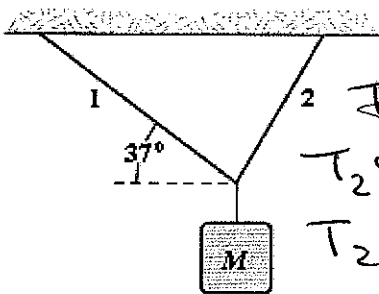

~~$$T_2 \sin 37 - T_1 \cos 37 = 0$$~~

~~$$T_2 \cos 37 - T_1 \sin 37 = 0$$~~

$$T_2 \sin 37 - T_1 \cos 37 = 0$$

$$T_2 \cos 37 + T_1 \sin 37 - Mg = 0$$

Solve for  $M$

- a. 36 lb

- b. 33 lb
- c. 41 lb
- d. 39 lb
- e. 56 lb

ANS: D

PTS: 3

DIF: Challenging

6. If  $\alpha = 40^\circ$ ,  $\beta = 60^\circ$ , and  $M = 4.0$  kg, determine the tension in string 1.

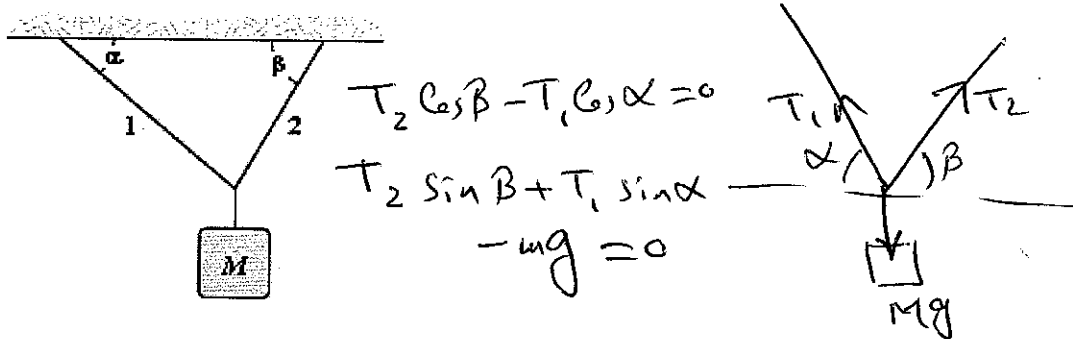

- a. 15 N
- b. 22 N
- c. 17 N
- d. 20 N
- e. 36 N

ANS: D

PTS: 2

DIF: Average

7. If  $\alpha = 40^\circ$  and the tension in string 2 is 30 N, determine  $M$ .

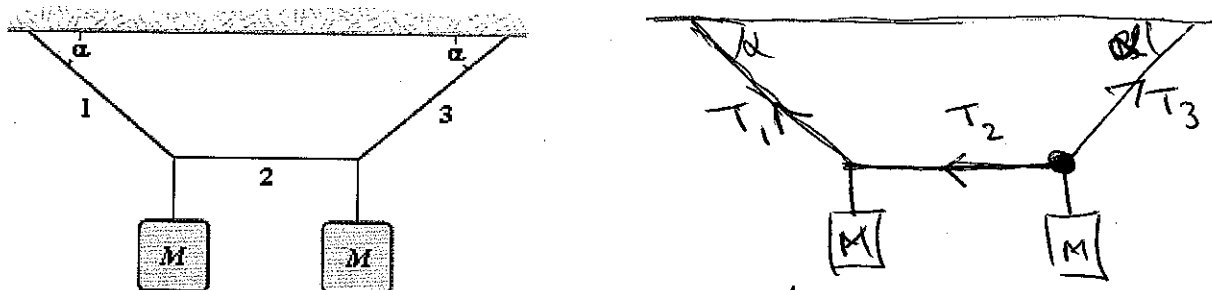

- a. 3.4 kg
- b. 3.6 kg
- c. 2.6 kg
- d. 4.9 kg
- e. 7.5 kg

$T_3 \cos \alpha - T_2 = 0$  ;  $T_3 \sin \alpha - Mg = 0$   
 ~~$T_1 \sin \alpha - Mg = 0$~~  Solve for  $M$

ANS: C

PTS: 2

DIF: Average

8. Two forces are the only forces acting on a 3.0-kg object which moves with an acceleration of  $3.0 \text{ m/s}^2$  in the positive  $y$  direction. If one of the forces acts in the positive  $x$  direction and has a magnitude of 8.0 N, what is the magnitude of the other force?

- a. 12 N
- b. 14 N
- c. 16 N
- d. 18 N
- e. 22 N

$\Sigma F = ma = 3 \times 3 = 9 \text{ N}$  ;  $F = \sqrt{F_x^2 + F_y^2}$

~~$8x = 6x + F_y$~~   
 $\Sigma F_x = ma_x = 0$ , then  $F_{1x} + F_{2x} = 0$   $8 + F_{2x} = 0$ ,  $F_{2x} = -8 \text{ N}$

$\Sigma F_y = ma_y$  ;  $F_{1y} + F_{2y} = ma_y$  ;  $0 + F_{2y} = 9 \text{ N}$  ,  $F_2 = \sqrt{F_{2x}^2 + F_{2y}^2}$   
 $= \sqrt{64 + 81} = 12 \text{ N}$

ANS: A

PTS: 2

DIF: Average

9. The horizontal surface on which the block slides is frictionless. If  $F = 20\text{ N}$  and  $M = 5.0\text{ kg}$ , what is the magnitude of the resulting acceleration of the block?

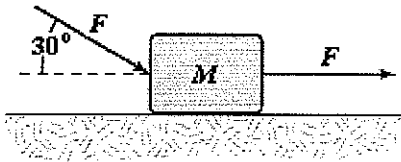

- a.  $5.3\text{ m/s}^2$
- b.  $6.2\text{ m/s}^2$
- c.  $7.5\text{ m/s}^2$
- d.  $4.7\text{ m/s}^2$
- e.  $3.2\text{ m/s}^2$

$$F + F \cos 30 = ma$$

$$20 + 20 \frac{\sqrt{3}}{2} = 5a$$

ANS: C

PTS: 2

DIF: Average

10. The only two forces acting on a body have magnitudes of  $20\text{ N}$  and  $35\text{ N}$  and directions that differ by  $80^\circ$ . The resulting acceleration has a magnitude of  $20\text{ m/s}^2$ . What is the mass of the body?

- a.  $2.4\text{ kg}$
- b.  $2.2\text{ kg}$
- c.  $2.7\text{ kg}$
- d.  $3.1\text{ kg}$
- e.  $1.5\text{ kg}$

$$F_{\text{net}} = ma = m(20) \rightarrow \text{①}$$

$$F_{\text{net}} = \sqrt{F_1^2 + F_2^2 + 2F_1F_2 \cos \theta}$$

$$= \sqrt{(20)^2 + (35)^2 + 2(20)(35) \cos 80}, \text{ plug in ① to find } m$$

ANS: B

PTS: 2

DIF: Average

11. If the only forces acting on a  $2.0\text{-kg}$  mass are  $\vec{F}_1 = (3\hat{i} - 8\hat{j})\text{ N}$  and  $\vec{F}_2 = (5\hat{i} + 3\hat{j})\text{ N}$ , what is the magnitude of the acceleration of the particle?

- a.  $1.5\text{ m/s}^2$
- b.  $6.5\text{ m/s}^2$
- c.  $4.7\text{ m/s}^2$
- d.  $9.4\text{ m/s}^2$
- e.  $7.2\text{ m/s}^2$

$$\vec{F}_{\text{net}} = (3+5)\hat{i} + (-8+3)\hat{j} = 8\hat{i} - 5\hat{j}$$

$$|\vec{F}_{\text{net}}| = \sqrt{64+25} \Rightarrow ma = 2a$$

solve for a

ANS: C

PTS: 2

DIF: Average

12. At an instant when a  $4.0\text{-kg}$  object has an acceleration equal to  $(5\hat{i} + 3\hat{j})\text{ m/s}^2$ , one of the two forces acting on the object is known to be  $(12\hat{i} + 22\hat{j})\text{ N}$ . Determine the magnitude of the other force acting on the object.

- a.  $2.0\text{ N}$
- b.  $13\text{ N}$
- c.  $18\text{ N}$
- d.  $1.7\text{ N}$
- e.  $20\text{ N}$

$$\vec{F} = m\vec{a}, \sum F_x = ma_x, \sum F_y = ma_y$$

$$12 + f_x = ma_x \rightarrow 12 + f_x = 4(5) \Rightarrow f_x = 8\hat{i}$$

$$22 + f_y = ma_y \rightarrow 22 + f_y = 4(3) \Rightarrow f_y = 10\hat{j}$$

$$f = \sqrt{f_x^2 + f_y^2} = \sqrt{64+100}$$

ANS: B

PTS: 2

DIF: Average

13. If  $F = 4.0\text{ N}$  and  $m = 2.0\text{ kg}$ , what is the magnitude  $a$  of the acceleration for the block shown below? The surface is frictionless.

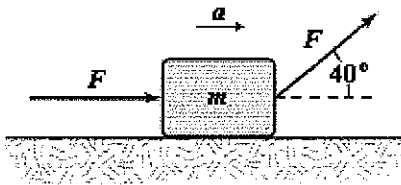

- a.  $5.3 \text{ m/s}^2$
- b.  $4.4 \text{ m/s}^2$
- c.  $3.5 \text{ m/s}^2$**
- d.  $6.2 \text{ m/s}^2$
- e.  $8.4 \text{ m/s}^2$

ANS: C

PTS: 2

DIF: Average

$$F + F \cos 40 = ma$$

Solve for a

$$a = \frac{F + F \cos 40}{m} = \frac{F(1 + \cos 40)}{m}$$

14. A block is pushed up a frictionless  $30^\circ$  incline by an applied force as shown. If  $F = 25 \text{ N}$  and  $M = 3.0 \text{ kg}$ , what is the magnitude of the resulting acceleration of the block?

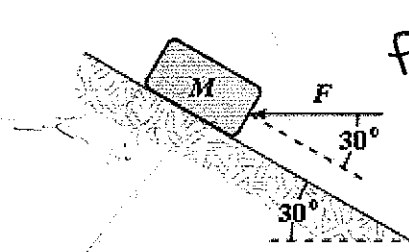

$$F \sin 60 - mg \sin 30 = ma$$

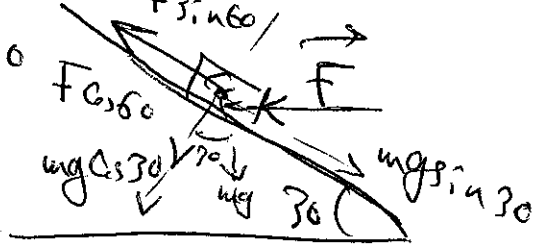

- a.  $2.3 \text{ m/s}^2$**
- b.  $4.6 \text{ m/s}^2$
- c.  $3.5 \text{ m/s}^2$
- d.  $2.9 \text{ m/s}^2$
- e.  $5.1 \text{ m/s}^2$

$$(25) \frac{\sqrt{3}}{2} - 3(9.8) \frac{1}{2} = 3a$$

find a

ANS: A

PTS: 2

DIF: Average

15. A  $5.0\text{-kg}$  object is suspended by a string from the ceiling of an elevator that is accelerating downward at a rate of  $2.6 \text{ m/s}^2$ . What is the tension in the string?

- a.  $49 \text{ N}$
- b.  $36 \text{ N}$**
- c.  $62 \text{ N}$
- d.  $13 \text{ N}$
- e.  $52 \text{ N}$

$$-T + mg = ma$$

$$-T + 5(9.8) = 5(-2.6)$$

$$T = 5(9.8) - 5(-2.6) = \text{N}$$



ANS: B

PTS: 2

DIF: Average

16. The tension in a string from which a  $4.0\text{-kg}$  object is suspended in an elevator is equal to  $44 \text{ N}$ . What is the acceleration of the elevator?

- a.  $11 \text{ m/s}^2$  upward
- b.  $1.2 \text{ m/s}^2$  upward**
- c.  $1.2 \text{ m/s}^2$  downward
- d.  $10 \text{ m/s}^2$  upward
- e.  $2.4 \text{ m/s}^2$  downward

$$T - mg = ma$$

$$44 - 4(9.8) = 4a$$

a is +ve, the direction of motion is in T direction



ANS: B

PTS: 2

DIF: Average

17. A  $5.0\text{-kg}$  mass is attached to the ceiling of an elevator by a rope whose mass is negligible. What force does the mass exert on the rope when the elevator has an acceleration of  $4.0 \text{ m/s}^2$  upward?

$$T - mg = ma$$

$$T = ma + mg = 5(4 + 9.8)$$

- a. 69 N downward
- b. 29 N downward
- c. 49 N downward
- d. 20 N downward
- e. 19 N downward

ANS: A

PTS: 2

DIF: Average

18. A 5.0-kg mass is suspended by a string from the ceiling of an elevator that is moving upward with a speed which is decreasing at a constant rate of 2.0 m/s in each second. What is the tension in the string supporting the mass?

- a. 49 N
- b. 39 N
- c. 59 N
- d. 10 N
- e. 42 N

$$T - mg = ma \quad , \quad a = -2 \text{ m/s}^2$$

$$T = ma + mg$$

$$= m(a + g) = 5(-2 + 9.8) \text{ N}$$

ANS: B

PTS: 2

DIF: Average

19. A person weighing 0.70 kN rides in an elevator that has an upward acceleration of 1.5 m/s<sup>2</sup>. What is the magnitude of the force of the elevator floor on the person?

- a. 0.11 kN
- b. 0.81 kN
- c. 0.70 kN
- d. 0.59 kN
- e. 0.64 kN

$$N - mg = ma$$

$$N = mg + ma = \frac{700}{9.8} (9.8 + 1.5) \text{ N}$$

$mg = 0.7 \text{ kN} = 700 \text{ N}$   
 $m = \frac{700}{9.8} \text{ kg}$

ANS: B

PTS: 2

DIF: Average

20. A 3.0-kg block slides on a frictionless 20° inclined plane. A force of 16 N acting parallel to the incline and up the incline is applied to the block. What is the acceleration of the block?

- a. 2.0 m/s<sup>2</sup> down the incline
- b. 5.3 m/s<sup>2</sup> up the incline
- c. 2.0 m/s<sup>2</sup> up the incline
- d. 3.9 m/s<sup>2</sup> down the incline
- e. 3.9 m/s<sup>2</sup> up the incline

$$F - mg \sin 20 = ma$$

$$16 - 3(9.8) \sin 20 = 3a$$

find  $a$



ANS: C

PTS: 2

DIF: Average

21. A 2.0-kg block slides on a frictionless 25° inclined plane. A force of 4.6 N acting parallel to the incline and up the incline is applied to the block. What is the acceleration of the block?

- a. 1.8 m/s<sup>2</sup> up the incline
- b. 2.3 m/s<sup>2</sup> up the incline
- c. 6.6 m/s<sup>2</sup> down the incline
- d. 1.8 m/s<sup>2</sup> down the incline
- e. 2.3 m/s<sup>2</sup> down the incline

Similar to 20

$$mg \sin \theta - F = ma; \quad a = 1.8 \text{ m/s}^2$$

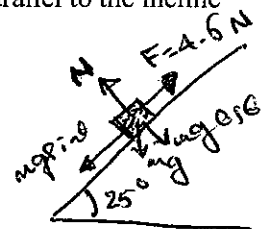

ANS: D

PTS: 2

DIF: Average

22. A 2.0-kg block slides on a frictionless 15° inclined plane. A force acting parallel to the incline is applied to the block. The acceleration of the block is 1.5 m/s<sup>2</sup> down the incline. What is the applied force?

- a. 8.1 N down the incline
- b. 3.0 N down the incline
- c. 2.1 N up the incline

$$mg \sin 15 - F = ma$$

$$2(9.8) \sin 15 - F = 2(-1.5)$$

Solve for  $F$

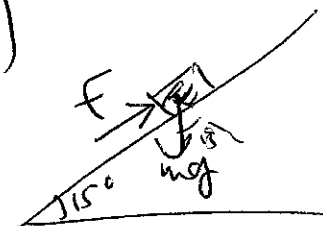

- d. 3.0 N up the incline
- e. 8.1 N up the incline

ANS: C                      PTS: 2                      DIF: Average

23. A 1.5-kg object has a velocity of  $5\hat{j}$  m/s at  $t = 0$ . It is accelerated at a constant rate for five seconds after which it has a velocity of  $(6\hat{i} + 12\hat{j})$  m/s. What is the magnitude of the resultant force acting on the object during this time interval?

- a. 3.8 N
- b. 3.2 N
- c. 2.8 N
- d. 4.3 N
- e. 4.6 N

$$a = \frac{\Delta v}{\Delta t} = \frac{6\hat{i} + 12\hat{j} - 5\hat{j}}{5} = \frac{6\hat{i} + 7\hat{j}}{5}$$

$$a = \sqrt{a_x^2 + a_y^2} = \sqrt{\left(\frac{36}{25}\right) + \left(\frac{49}{25}\right)}, \quad F = ma$$

ANS: C                      PTS: 2                      DIF: Average

24. A 1.5-kg object has a velocity of  $5\hat{j}$  m/s at  $t = 0$ . It is accelerated at a constant rate for five seconds after which it has a velocity of  $(6\hat{i} + 12\hat{j})$  m/s. What is the direction of the resultant force acting on the object during this time interval?

- a.  $65^\circ$
- b.  $56^\circ$
- c.  $61^\circ$
- d.  $49^\circ$
- e.  $27^\circ$

*Similar to 23*

$$v = v_0 + at$$

$$\hat{i}v_x + \hat{j}v_y = \hat{i}v_{0x} + \hat{j}v_{0y} + a_x\hat{i}t + a_y\hat{j}t$$

$$6\hat{i} + 12\hat{j} = 0 + 5\hat{j} + a_x\hat{i}(5) + a_y\hat{j}(5)$$

ANS: D                      PTS: 2                      DIF: Average  $a_x = \frac{6\text{ m/s}^2}{5}, a_y = \frac{12-5}{5} = \frac{7}{5} \text{ m/s}^2$

25. A 2.0-kg object has a velocity of  $4.0\hat{i}$  m/s at  $t = 0$ . A constant resultant force of  $(2.0\hat{i} + 4.0\hat{j})$  N then acts on the object for 3.0 s. What is the magnitude of the object's velocity at the end of the 3.0-s interval?

- a. 9.2 m/s
- b. 6.3 m/s
- c. 8.2 m/s
- d. 7.2 m/s
- e. 7.7 m/s

*Similar to 23*

$$v = v_0 + at$$

$$v_x = 4 + \frac{2}{2}(3) = 7 \text{ m/s}$$

$$v_y = 0 + \frac{4}{2}(3) = 6 \text{ m/s}$$

$$v = \sqrt{v_x^2 + v_y^2} = 9.2 \text{ m/s}$$

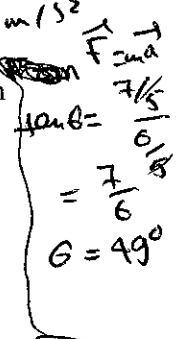

ANS: A                      PTS: 2                      DIF: Average

26. A 1.5-kg mass has an acceleration of  $(4.0\hat{i} - 3.0\hat{j})$  m/s<sup>2</sup>. Only two forces act on the mass. If one of the forces is  $(2.0\hat{i} - 1.4\hat{j})$  N, what is the magnitude of the other force?

- a. 4.1 N
- b. 6.1 N
- c. 5.1 N
- d. 7.1 N
- e. 2.4 N

$$2.0 + f_x = ma_x \rightarrow f_x = 2 - (1.5)(4) = -4 \text{ N}$$

$$-1.4 + f_y = ma_y \rightarrow f_y = -1.4 + 1.5(3) = 3.1 \text{ N}$$

$$f = -4\hat{i} + 3.1\hat{j}, \quad f = \sqrt{f_x^2 + f_y^2}$$

ANS: C                      PTS: 2                      DIF: Average

27. Only two forces act on a 3.0-kg mass. One of the forces is 9.0 N east, and the other is 8.0 N in the direction of  $62^\circ$  north of west. What is the magnitude of the acceleration of the mass?

- a.  $2.0 \text{ m/s}^2$
- b.  $2.4 \text{ m/s}^2$
- c.  $3.3 \text{ m/s}^2$

$$F = \sqrt{F_1^2 + F_2^2 + 2F_1F_2 \cos(\theta)}$$

$$= \sqrt{9^2 + 8^2 + 2(9)(8)\cos(118^\circ)}$$

$$= 8.79 \text{ N}$$

$$a = \frac{F}{m} = \frac{8.79}{3} = 2.93 \text{ m/s}^2$$

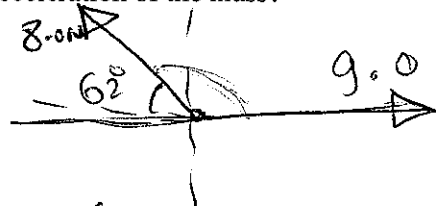

- d.  $2.9 \text{ m/s}^2$
- e.  $5.7 \text{ m/s}^2$

ANS: D

PTS: 2

DIF: Average

28. A book is placed on a chair. Then a videocassette is placed on the book. The floor exerts a normal force
- a. on all three.
  - b. only on the book.
  - c. only on the chair.
  - d. upwards on the chair and downwards on the book.
  - e. only on the objects that you have defined to be part of the system.

ANS: C

PTS: 1

DIF: Easy

29. The apparent weight of a fish in an elevator is greatest when the elevator
- a. moves downward at constant velocity.
  - b. moves upward at constant velocity.
  - c. accelerates downward.
  - d. accelerates upward.
  - e. is not moving.

ANS: D

PTS: 1

DIF: Easy

30. The vector sum of three co-planar forces
- a. must be zero.
  - b. must be perpendicular to one of the three.
  - c. must be parallel to one of the three.
  - d. must be perpendicular to the plane.
  - e. may have any direction in the plane.

ANS: E

PTS: 1

DIF: Easy

31. When the vector sum of three co-planar forces,  $\vec{A}$ ,  $\vec{B}$  and  $\vec{C}$ , is parallel to  $\vec{A}$ , we can conclude that  $\vec{B}$  and  $\vec{C}$
- a. must sum to zero.
  - b. must be equal and opposite.
  - c. must have equal and opposite components perpendicular to  $\vec{A}$ .
  - d. must have equal and opposite components parallel to  $\vec{A}$ .
  - e. must have equal and opposite components parallel and perpendicular to  $\vec{A}$ .

ANS: C

PTS: 1

DIF: Easy

32. A constant force is applied to a body that is already moving. The force is directed at an angle of 60 degrees to the direction of the body's velocity. What is most likely to happen is that
- a. the body will stop moving.
  - b. the body will move in the direction of the force.
  - c. the body's velocity will increase in magnitude but not change direction.
  - d. the body will gradually change direction more and more toward that of the force while speeding up.
  - e. the body will first stop moving and then move in the direction of the force.

ANS: D

PTS: 1

DIF: Easy

33. A juggler throws two balls up to the same height so that they pass each other halfway up when A is rising and B is descending. Ignore air resistance and buoyant forces. Which statement is true of the two balls at that point?
- There is an residual upward force from the hand on each ball.
  - There is a greater residual force from the hand on A than there is on B.
  - Only gravity acts on B but there is an additional residual force from the hand on A.
  - There is an additional downwards force besides gravity on each ball.
  - The only force acting on each ball is the gravitational force.

ANS: E                      PTS: 1                      DIF: Easy

34. A bumper car is moving at constant velocity when another bumper car starts to push on it with a constant force at an angle of 60 degrees with respect to the first car's initial velocity. The second bumper car continues pushing in exactly that direction for some time. What is most likely to happen is that
- the first car will stop moving.
  - the first car will move in the direction of the force.
  - the first car's velocity will increase in magnitude but not change direction.
  - the first car's velocity will gradually change direction more and more toward that of the force while increasing in magnitude.
  - the first car's velocity will gradually change direction more and more toward that of the force while decreasing in magnitude.

ANS: D                      PTS: 1                      DIF: Easy

35. You have a machine which can accelerate pucks on frictionless ice. Starting from rest, the puck travels a distance  $x$  in time  $t$  when force  $F$  is applied. If force  $3F$  is applied, the distance the puck travels in time  $t$  is

- $x$ .
- $(3/2)x$ .
- $3x$ .
- $(9/2)x$ .
- $9x$ .

$$F = ma, \quad x_1 = v_0 t + \frac{1}{2} a t^2 = \frac{1}{2} a t^2 \quad \textcircled{1} = \frac{1}{2} \frac{F}{m} t^2 \quad \textcircled{1}$$

$$3F = ma, \quad x_2 = v_0 t + \frac{1}{2} a t^2 = \frac{1}{2} \frac{3F}{m} t^2 \quad \textcircled{2}$$

$$x_2 = 3x_1$$

ANS: C                      PTS: 1                      DIF: Easy

36. A constant force  $F$  is applied to a body of mass  $m$  that initially is headed east at velocity  $v_0$  until its velocity becomes  $-v_0$ . The total time of travel is  $2t$ . The total distance the body travels in that time is

- $\frac{1}{2} \frac{F}{m} t^2$ .
- $\frac{F}{m} t^2$ .
- $v_0 t - \frac{1}{2} \frac{F}{m} t^2$ .
- $v_0 t + \frac{1}{2} \frac{F}{m} t^2$ .
- $2 \left( v_0 t + \frac{1}{2} \frac{F}{m} t^2 \right)$ .

$$a = \frac{v_0 + v_0}{t} = \frac{2v_0}{t} \rightarrow v_0 = \frac{at}{2}$$

$$x = v_0 t + \frac{1}{2} \left( \frac{2v_0}{t} \right) t^2 = 2v_0 t$$

$$x = 2 \frac{at}{2} t = at^2 = \frac{F}{m} t^2$$

ANS: B                      PTS: 2                      DIF: Average

37. The first of two identical boxes of mass  $m$  is sitting on level ground. The second box is sitting on a ramp that makes a  $20^\circ$  angle with the ground. The normal force of the level ground on the first box is  $N_L$ ; the normal force of the ramp on the second box is  $N_R$ . Which statement is correct?

- a.  $N_R = N_L = mg$ .
- b.  $N_L = mg; N_R = mg \sin 20^\circ$ .
- c.  $N_L = mg; N_R = mg \cos 20^\circ$ .
- d.  $N_L = mg; N_R = -mg \cos 20^\circ$ .
- e.  $N_R = -N_L = -mg$ .

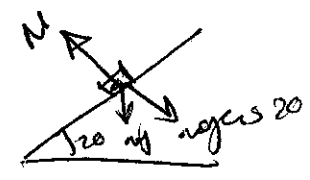
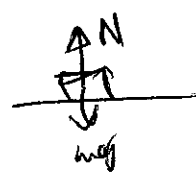

ANS: C                      PTS: 1                      DIF: Easy

38. The first of two identical boxes of mass  $m$  is sitting on level ground. The second box is sitting on a ramp that makes an angle with the ground. When a force of magnitude  $F$  is applied to each box in a direction parallel to the surface it is on, upwards on the box on the ramp, neither box moves. Which statement comparing the friction force on the box on the level,  $f_L$ , to the friction force on the box on the ramp,  $f_R$ , is correct?
- a.  $f_R = f_L$ .
  - b.  $f_R > f_L$ .
  - c.  $f_R < f_L$ .
  - d. The coefficient of static friction is needed to determine the correct answer.
  - e. Depending on the values of the coefficient of static friction, the angle of elevation of the ramp, the mass of the boxes, and the applied force, answers (a), (b), and (c) are each a possible correct answer.

ANS: E                      PTS: 3                      DIF: Challenging

39. The total force needed to drag a box at constant speed across a surface with coefficient of kinetic friction  $\mu_k$  is least when the force is applied at an angle  $\theta$  such that
- a.  $\sin \theta = \mu_k$ .
  - b.  $\cos \theta = \mu_k$ .
  - c.  $\tan \theta = \mu_k$ .
  - d.  $\cot \theta = \mu_k$ .
  - e.  $\sec \theta = \mu_k$ .

$mg \cos \theta = N$   
 $mg \sin \theta = f = \mu N = \mu mg \cos \theta$   
 $\mu = \tan \theta$

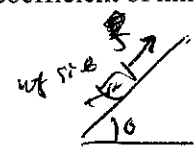

ANS: C                      PTS: 3                      DIF: Challenging

40. A heavy weight is supported by two cables that exert tensions of magnitude  $T_1$  and  $T_2$ . Which statement is correct?

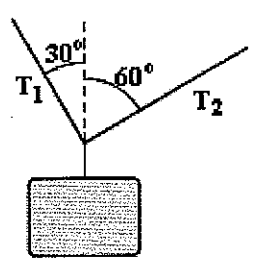

in  $x$ :  $T_2 \sin 60 - T_1 \sin 30 = 0$   
 $\frac{T_2}{T_1} = \frac{\sin 30}{\sin 60} = \frac{1/2}{\sqrt{3}/2} = \frac{1}{\sqrt{3}}$   
 $(T_2 = \frac{T_1}{\sqrt{3}} \Rightarrow T_1 > T_2$

- a.  $T_1 = T_2$ .
- b.  $T_{1y} = T_{2y}$ .
- c.  $T_1 > T_2$ .
- d.  $T_1 < T_2$ .
- e. We need the mass of the box in order to determine the correct answer.

ANS: C                      PTS: 2                      DIF: Average

41. Two people, each of 70 kg mass, are riding in an elevator. One is standing on the floor. The other is hanging on a rope suspended from the ceiling. Compare the force  $\vec{F}_F$  the floor exerts on the first person to the force  $\vec{F}_R$  the rope exerts on the second person. Which statement is correct?
- They are equal and opposite in direction.
  - They are equal and have the same direction.
  - $\vec{F}_R$  is greater than  $\vec{F}_F$ , but they have the same direction.
  - $\vec{F}_R$  is greater than  $\vec{F}_F$ , but they have opposite directions.
  - $\vec{F}_R$  is less than  $\vec{F}_F$ , but they have the same direction.

ANS: B      PTS: 1      DIF: Easy

42. Two people, each of 70 kg mass, are riding in an elevator. One is standing on the floor. The other is hanging on a rope suspended from the ceiling. Compare the acceleration  $\vec{a}_F$  of the first person to the acceleration  $\vec{a}_R$  of the second person. Which statement is correct?
- They are equal and opposite in direction.
  - They are equal and have the same direction.
  - The acceleration  $\vec{a}_R$  is greater than  $\vec{a}_F$ , but they have the same direction.
  - The acceleration  $\vec{a}_R$  is greater than  $\vec{a}_F$ , but they have opposite directions.
  - The acceleration  $\vec{a}_R$  is less than  $\vec{a}_F$ , but they have the same direction.

ANS: B      PTS: 1      DIF: Easy

43. The horizontal surface on which the objects slide is frictionless. If  $M = 2.0$  kg, the tension in string 1 is 12 N. Determine  $F$ .

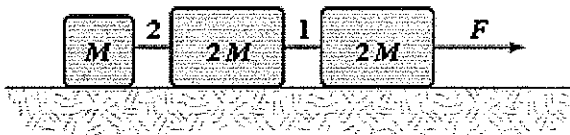

$$F = (M + 2M + 2M)a = 5Ma \rightarrow (1)$$

for 1st 2M:

$$F - 12 = 2Ma \rightarrow (2)$$

from (1)  $Ma = \frac{F}{5}$ , then (2) becomes

$$F - 12 = 2 \left( \frac{F}{5} \right) \rightarrow 5F - 60 = 2F$$

$$3F = 60 \text{ N} \rightarrow F = 20 \text{ N}$$

- 25 N
- 20 N
- 30 N
- 35 N
- 40 N

ANS: B      PTS: 2      DIF: Average

44. The horizontal surface on which the objects slide is frictionless. If  $F = 12$  N, what is the tension in string 1?

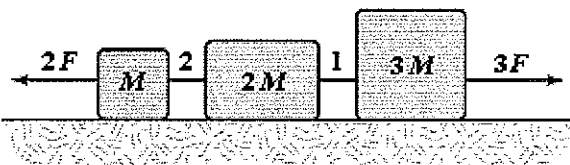

$$\text{for } 3M: 3F - T_1 = 3Ma$$

$$3(12) - T_1 = 3Ma$$

$$T_1 = 36 - 3Ma \rightarrow (1)$$

$$\text{for all: } 3F - 2F = (M + 2M + 3M)a = 6Ma$$

$$F = 6aM \rightarrow a = \frac{F}{6M}$$

then (1) reads

$$T_1 = 36 - 3M \left( \frac{F}{6M} \right) = 36 - \frac{F}{2} = 30 \text{ N}$$

- 35 N
- 30 N
- 40 N
- 45 N

e. 25 N

ANS: B

PTS: 3

DIF: Challenging

45. The surface of the inclined plane shown is frictionless. If  $F = 30$  N, what is the magnitude of the force exerted on the 3.0-kg block by the 2.0-kg block?

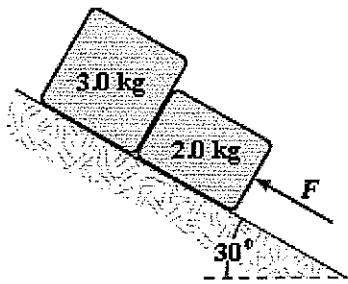

for all  $F - (3+2)g \sin \theta = 5a$

$a = 1.1 \text{ m/s}^2$

for 3 kg's

$F_{23} - mg \sin 30 = 3a$

$F_{23} = 3a + 3(9.8)(\sin 30)$   
 $\downarrow$   
 $1.1 \text{ m/s}^2$   
 $= 18 \text{ N}$

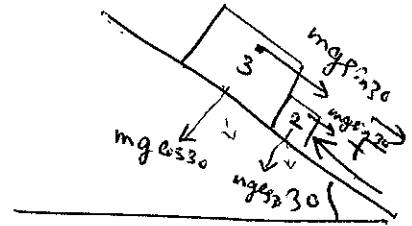

- a. 18 N  
 b. 27 N  
 c. 24 N  
 d. 21 N  
 e. 15 N

ANS: A

PTS: 3

DIF: Challenging

46. If  $P = 6.0$  N, what is the magnitude of the force exerted on block 1 by block 2?

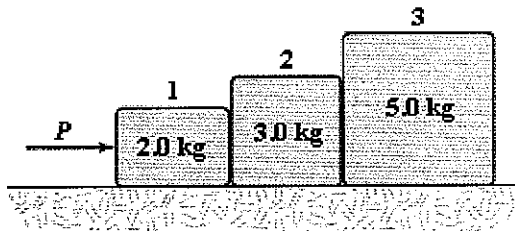

for all  $P = (2+3+5)a$

$a = \frac{6}{10} \text{ m/s}^2$

$a = 0.6 \text{ m/s}^2$

for block #1

$P - F_{21} = 2a \rightarrow 6 - F_{21} = 2(0.6)$

$F_{21} = 6 - 1.2 = 4.8 \text{ N}$

- a. 6.4 N  
 b. 5.6 N  
 c. 4.8 N  
 d. 7.2 N  
 e. 8.4 N

ANS: C

PTS: 2

DIF: Average

47. If  $F = 5.0$  N, what is the magnitude of the force exerted by block 2 on block 1?

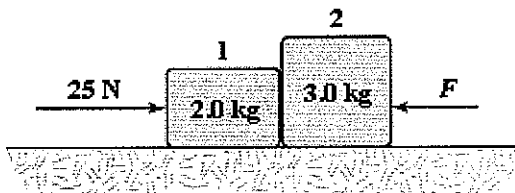

for all's

$25 - F = (2+3)a$

$25 - 5 = 5a \rightarrow a = 4 \text{ m/s}^2$

for block #1

$25 - F_{21} = 2a \rightarrow F_{21} = 25 - 2(4)$   
 $= 25 - 8 = 17 \text{ N}$

- a. 17 N  
 b. 19 N  
 c. 21 N

- d. 23 N  
e. 5.0 N

ANS: A                      PTS: 2                      DIF: Average

48. An astronaut who weighs 800 N on the surface of the earth lifts off from planet Zuton in a space ship. The free-fall acceleration on Zuton is  $3.0 \text{ m/s}^2$  (down). At the moment of liftoff the acceleration of the space ship is  $0.50 \text{ m/s}^2$  (up). What is the magnitude of the force of the space ship on the astronaut?

- a. 41 N  
b. 0.29 kN  
c. 0.24 kN  
d. 0.20 kN  
e. 0.37 kN

earth  $w = mg$ ,  $m = \frac{800}{9.8} \text{ kg}$

$F - mg = ma$

$F = mg + ma = \frac{800}{9.8} (0.5 + 3) = 0.29 \text{ kN}$



ANS: B                      PTS: 2                      DIF: Average

49. The horizontal surface on which the objects slide is frictionless. If  $M = 1.0 \text{ kg}$  and the magnitude of the force of the small block on the large block is 5.2 N, determine  $F$ .

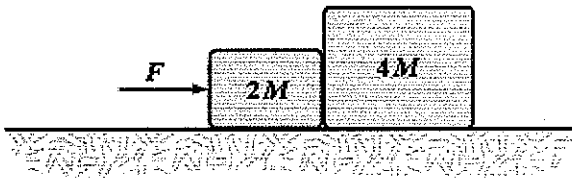

for all:  $F = 5Ma \rightarrow \textcircled{1}$

Per large block:

$5.2 = 4Ma \rightarrow a = \frac{5.2}{4M}$

then  $\textcircled{1}$  reads

$F = 5M \left( \frac{5.2}{4M} \right) = 7.8 \text{ N}$

- a. 6.0 N  
b. 9.0 N  
c. 7.8 N  
d. 4.8 N  
e. 4.1 N

ANS: C                      PTS: 2                      DIF: Average

50. The horizontal surface on which the objects slide is frictionless. If  $F = 6.0 \text{ N}$  and  $M = 1.0 \text{ kg}$ , what is the magnitude of the force exerted on the large block by the small block?

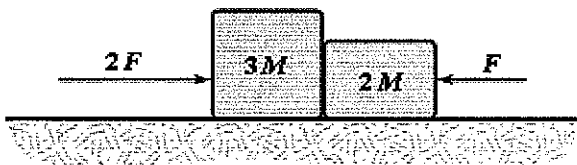

for all:  $2F - F = 5Ma$

$F = 5Ma$ ,  $a = \frac{F}{5M} = \frac{6}{5} \text{ m/s}^2$

for large block:

$2F - F_{12} = 3Ma$ ,  $F_{12} = 2F - 3Ma$

$F_{12} = 2(6) - 3M \left( \frac{6}{5} \right) = 12 - \frac{18}{5} = 8.4 \text{ N}$

- a. 7.7 N  
b. 9.8 N  
c. 9.1 N  
d. 8.4 N  
e. 6.5 N

ANS: D                      PTS: 2                      DIF: Average

51. A 6.0-kg object is suspended by a vertical string from the ceiling of an elevator which is accelerating upward at a rate of  $1.8 \text{ m/s}^2$ . Determine the tension in the string.

- a. 11 N  
b. 70 N  
c. 48 N

$T - mg = ma$

$T = m(a + g) = 6(1.8 + 9.8) \approx 70 \text{ N}$

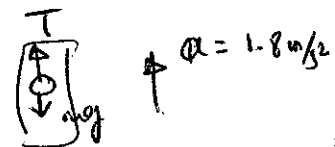

- d. 59 N
- e. 62 N

ANS: B                      PTS: 2                      DIF: Average

52. An 8.0-kg object rests on the floor of an elevator which is accelerating downward at a rate of  $1.3 \text{ m/s}^2$ . What is the magnitude of the force the object exerts on the floor of the elevator?

- a. 59 N
- b. 10 N
- c. 89 N
- d. 68 N
- e. 78 N

$$mg - N = ma, \quad N = mg - ma$$

$$N = m(g - a)$$

$$= 8(9.8 - 1.3) = 68 \text{ N}$$

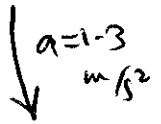

ANS: D                      PTS: 2                      DIF: Average

53. A 70-kg stunt artist rides in a rocket sled which slides along a flat inclined surface. At an instant when the sled's acceleration has a horizontal component of  $6.0 \text{ m/s}^2$  and a downward component of  $2.8 \text{ m/s}^2$ , what is the magnitude of the force on the rider by the sled?

- a. 0.83 kN
- b. 0.98 kN
- c. 0.65 kN
- d. 0.68 kN
- e. 0.72 kN

$$F = ma, \quad a = \sqrt{6.0^2 + 2.8^2} = \sqrt{36 + 7.84} = \sqrt{43.84} = 6.62 \text{ m/s}^2$$

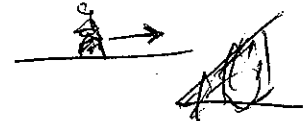

ANS: C                      PTS: 3                      DIF: Challenging

54. If  $F = 40 \text{ N}$  and  $M = 1.5 \text{ kg}$ , what is the tension in the string connecting  $M$  and  $2M$ ? Assume that all surfaces are frictionless.

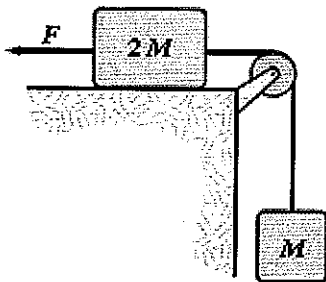

For  $2M$

$$F - T = 2Ma \rightarrow (1)$$

For  $M$

$$T - Mg = Ma \rightarrow (2)$$

from (2)  $a = \frac{T - Mg}{M}$

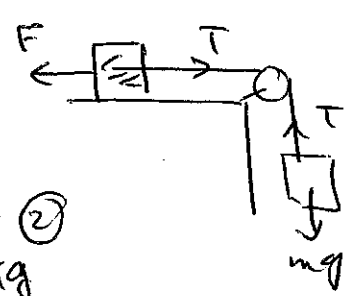

in (1)  $F - T = 2M \left( \frac{T - Mg}{M} \right)$

$$F - T = 2T - 2Mg \Rightarrow F + 2Mg = 3T$$

$$T = \frac{F + 2Mg}{3} = 23.1 \text{ N}$$

- a. 13 N
- b. 23 N
- c. 36 N
- d. 15 N
- e. 28 N

ANS: B                      PTS: 2                      DIF: Average

55. The system shown is released from rest and moves 50 cm in 1.0 s. What is the value of  $M$ ? All surfaces are frictionless.

$$x = \frac{v_0}{t} + \frac{1}{2}at^2$$

$$= \frac{1}{2}at^2 \rightarrow a = \frac{2x}{t^2} = \frac{2(0.5)}{1} = 1 \text{ m/s}^2$$

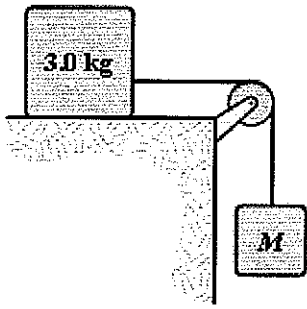

for  $M_2$   
 $Mg - T = Ma$

for  $3 \text{ kg}$   
 $T = Ma = 3(1) = 3 \text{ N}$

then for  $M$   
 ~~$Mg - T = Ma$~~   
 $Mg - 3 = M(1)$

$9 - 8M - M = 3$

$8 - 8M = 3 \rightarrow M = \frac{3}{8 \cdot 8} = 0.34 \text{ kg}$

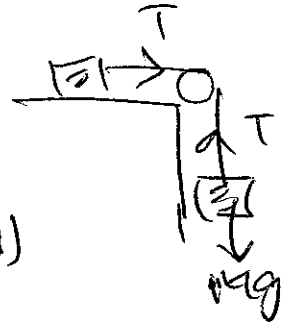

- a. 0.42 kg
- b. 0.34 kg**
- c. 0.50 kg
- d. 0.59 kg
- e. 0.68 kg

ANS: B

PTS: 2

DIF: Average

56. If  $F = 40 \text{ N}$  and  $M = 2.0 \text{ kg}$ , what is the magnitude of the acceleration of the suspended object? All surfaces are frictionless.

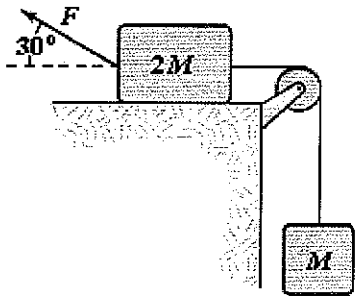

for  $2M$

$F \cos 30 - T = 2Ma \rightarrow \textcircled{1}$

for  $M$

$T - Mg = Ma \rightarrow \textcircled{2}$

from  $\textcircled{1}$  &  $\textcircled{2}$   $\rightarrow \textcircled{1} + \textcircled{2}$

$F \cos 30 - Mg = 3Ma \rightarrow a = 2.5 \text{ m/s}^2$

then  $\textcircled{2}$  gives

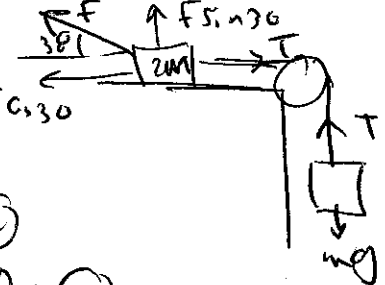

- a. 1.2  $\text{m/s}^2$
- b. 2.0  $\text{m/s}^2$
- c. 1.5  $\text{m/s}^2$
- d. 2.5  $\text{m/s}^2$**
- e. 5.6  $\text{m/s}^2$

ANS: D

PTS: 3

DIF: Challenging

57. If  $M = 2.2 \text{ kg}$ , what is the tension in the connecting string? The pulley and all surfaces are frictionless.

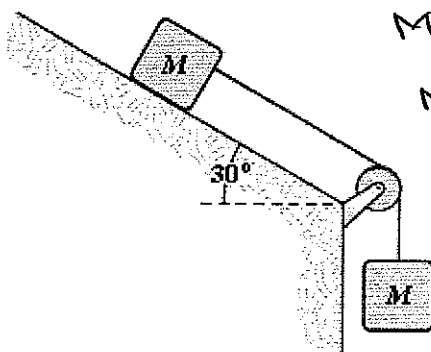

$Mg \sin 30 + T = Ma \rightarrow \textcircled{1}$

$Mg - T = Ma \rightarrow \textcircled{2}$

$\textcircled{1} + \textcircled{2}$

$Mg \sin 30 + Mg = 2Ma$

$a = 7.35 \text{ m/s}^2$

then  $\textcircled{2}$  reads

$T = M(g - a) = 5.39 \text{ N}$

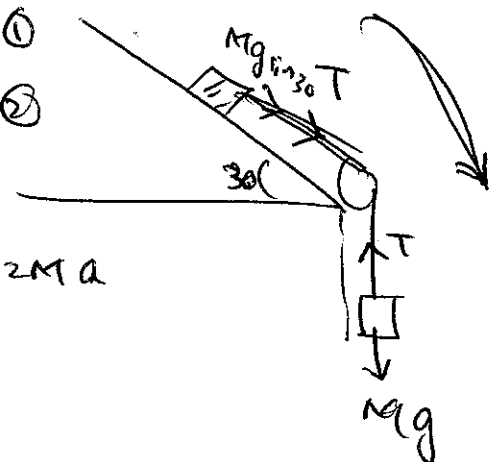

- a. 6.4 N
- b. 5.9 N**

- c. 5.4 N
- d. 6.9 N
- e. 8.3 N

ANS: C

PTS: 3

DIF: Challenging

58. A 5.0-kg mass sits on the floor of an elevator that has a downward acceleration of  $1.0 \text{ m/s}^2$ . On top of the 5.0-kg mass is an object of unknown mass. The force of the elevator on the 5.0-kg mass is 80 N up. Determine the unknown mass.

- a. 3.3 kg
- b. 2.4 kg
- c. 1.6 kg
- d. 4.1 kg
- e. 5.0 kg

$$Mg - 80 = Ma$$

$$(5+m)g - 80 = (5+m)(-1)$$

$$(5+m)g - (5+m) = 80$$

$$8 \cdot (5+m) = 80$$

$$m = 4 \text{ kg}$$

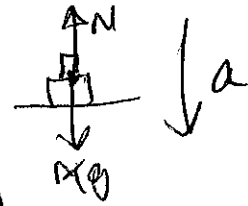

ANS: D

PTS: 2

DIF: Average

$m = 4 \text{ kg}$

59. If the tension,  $T$ , is 15 N and the magnitude of the acceleration,  $a$ , is  $3.0 \text{ m/s}^2$ , what is the mass,  $m$ , of the suspended object? Assume that all surfaces and the pulley are frictionless.

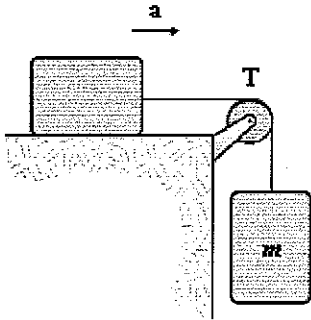

$$mg - T = ma$$

$$mg - 15 = m(3)$$

$$m(g - 3) = 15$$

$$m = 2.2 \text{ kg}$$

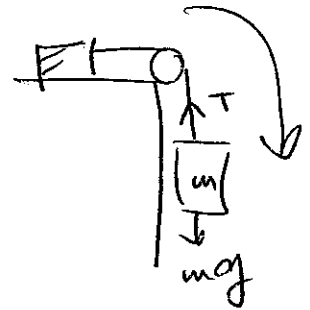

- a. 3.1 kg
- b. 2.5 kg
- c. 2.8 kg
- d. 2.2 kg
- e. 3.7 kg

ANS: D

PTS: 2

DIF: Average

60. If  $F = 8.0 \text{ N}$  and  $M = 1.0 \text{ kg}$ , what is the tension in the connecting string? The pulley and all surfaces are frictionless.

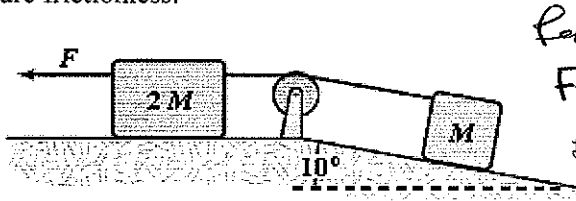

for  $2M$ :

$$F - T = 2Ma \rightarrow (1)$$

for  $M$ :

$$T - Mg \sin 10 = Ma \rightarrow (2)$$

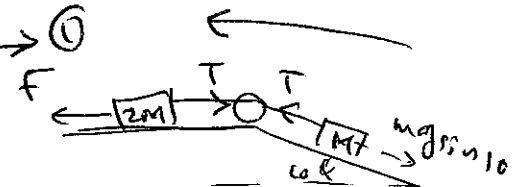

- a. 4.1 N
- b. 3.5 N
- c. 3.8 N
- d. 3.1 N
- e. 4.8 N

$$(1) + (2): F - Mg \sin 10 = 3Ma, \quad a = 2.1 \text{ m/s}^2$$

$$\text{then } (1) \quad T = F - 2Ma = 8 - 2(1)(2.1) = 3.8 \text{ N}$$

ANS: C

PTS: 2

DIF: Average

61. In the figure, if  $F = 2.0 \text{ N}$  and  $M = 1.0 \text{ kg}$ , what is the tension in the connecting string? The pulley and all surfaces are frictionless.

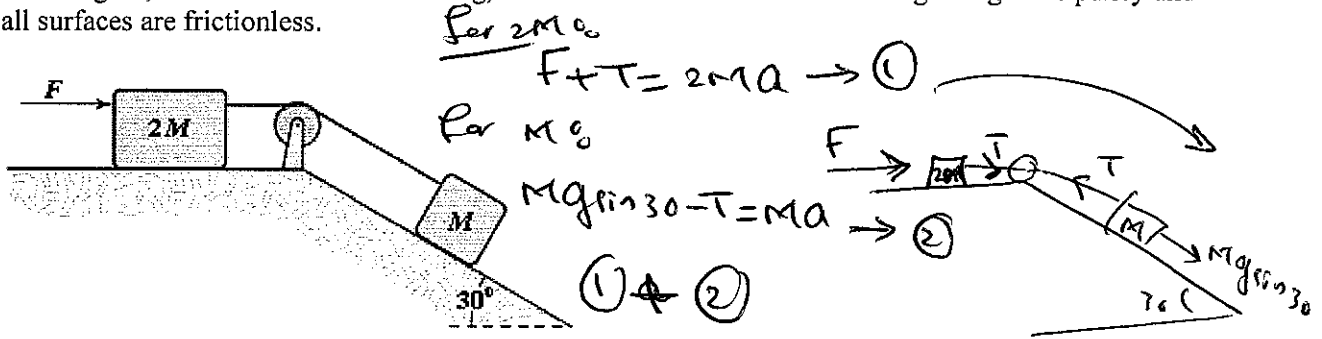

- a. 2.6 N  
b. 1.1 N  
c. 2.1 N  
d. 1.6 N  
e. 3.7 N

ANS: A

PTS: 2

DIF: Average

62. A 4.0-kg block slides down a  $35^\circ$  incline at a constant speed when a 16-N force is applied acting up and parallel to the incline. What is the coefficient of kinetic friction between the block and the surface of the incline?

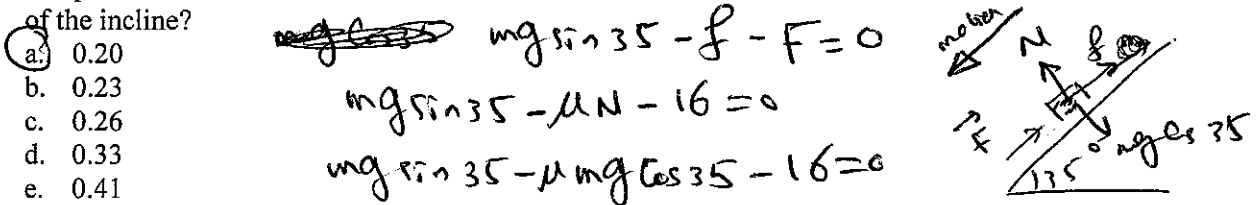

ANS: A

PTS: 3

DIF: Challenging  $\mu = 0.20$

63. A block is pushed across a horizontal surface by the force shown. If the coefficient of kinetic friction between the block and the surface is 0.30,  $F = 20 \text{ N}$ ,  $\theta = 30^\circ$ , and  $M = 3.0 \text{ kg}$ , what is the magnitude of the acceleration of the block?

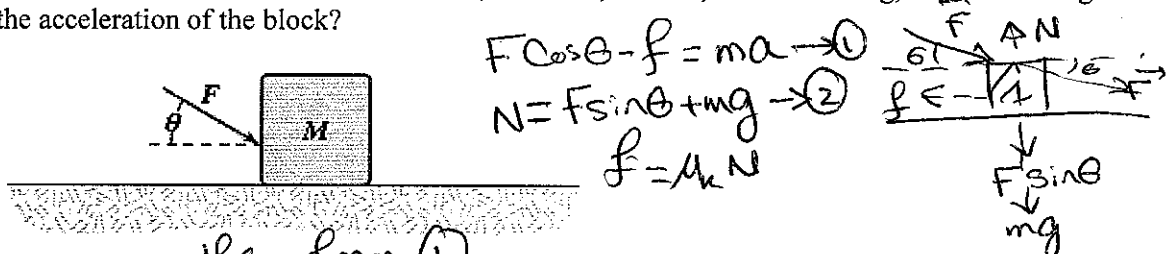

- a.  $2.8 \text{ m/s}^2$   
b.  $2.3 \text{ m/s}^2$   
c.  $1.8 \text{ m/s}^2$   
d.  $3.3 \text{ m/s}^2$   
e.  $5.4 \text{ m/s}^2$

ANS: C

PTS: 2

DIF: Average

64. A 3.0-kg block moves up a  $40^\circ$  incline with constant speed under the action of a 26-N force acting up and parallel to the incline. What magnitude force must act up and parallel to the incline for the block to move down the incline at constant velocity?

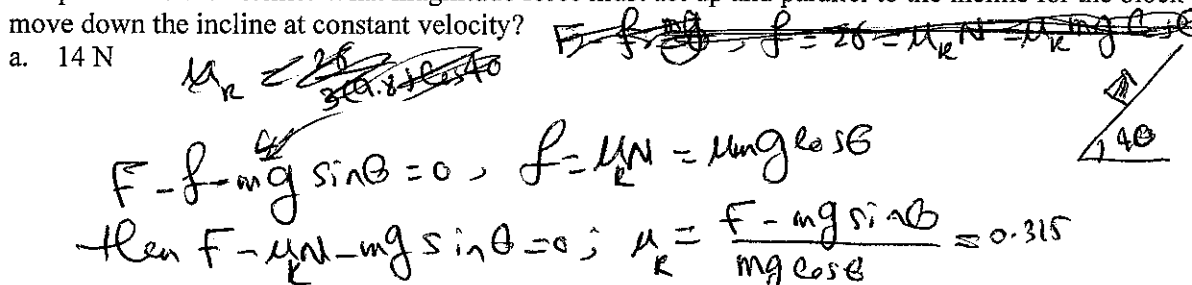

- a. 14 N

- b. 12 N  
c. 16 N  
d. 18 N  
e. 25 N

ANS: B

PTS: 2

DIF: Average

$$F = f + mg \sin \theta$$

$$F = \mu mg \cos \theta + mg \sin \theta$$

$$F = mg (\mu \cos \theta + \sin \theta)$$

$$= 11.7 \text{ N}$$

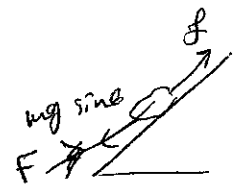

65. The block shown is pulled across the horizontal surface at a constant speed by the force shown. If  $M = 5.0 \text{ kg}$ ,  $F = 14 \text{ N}$  and  $\theta = 35^\circ$ , what is the coefficient of kinetic friction between the block and the horizontal surface?

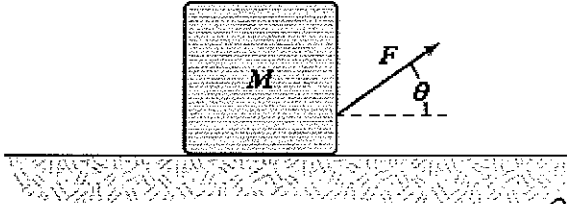

$$F \cos \theta - f = 0$$

$$f = F \cos \theta$$

$$f = 14 \cos 35$$

$$F \sin \theta + N = mg$$

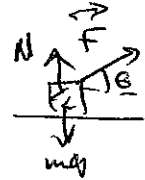

- a. 0.44  
b. 0.33  
c. 0.38  
d. 0.28  
e. 0.17

ANS: D

PTS: 2

DIF: Average

$$f = \mu N = \mu (mg - F \sin \theta)$$

$$14 \cos 35 = \mu (5)(9.8) - 14 \sin 35$$

$$\mu = \frac{14 \cos 35}{5(9.8) - 14 \sin 35} = 0.28$$

66. A box rests on the (horizontal) back of a truck. The coefficient of static friction between the box and the surface on which it rests is 0.24. What maximum distance can the truck travel (starting from rest and moving horizontally with constant acceleration) in 3.0 s without having the box slide?

- a. 14 m  
b. 11 m  
c. 19 m  
d. 24 m  
e. 29 m

ANS: B

PTS: 2

DIF: Average

$$-f = ma = \mu mg, a = \mu g$$

$$x = v_0 t + \frac{1}{2} a t^2 = \frac{1}{2} \mu g t^2$$

$$= \frac{1}{2} (0.24)(9.8)(9) = 10.58 \text{ m}$$

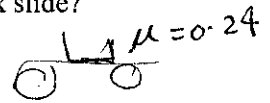

67. In a game of shuffleboard (played on a horizontal surface), a puck is given an initial speed of 6.0 m/s. It slides a distance of 9.0 m before coming to rest. What is the coefficient of kinetic friction between the puck and the surface?

- a. 0.20  
b. 0.18  
c. 0.15  
d. 0.13  
e. 0.27

ANS: A

PTS: 2

DIF: Average

$$-f = ma, f = \mu N$$

$$v^2 = v_0^2 + 2ax, 0 = 36 + 2a(9) \rightarrow a = -\frac{36}{18} = -2 \text{ m/s}^2$$

$$f = ma = \mu N = \mu mg, \mu = \frac{a}{g} = \frac{2}{9.8} = 0.20$$

68. A 2.0-kg block slides on a rough horizontal surface. A force (magnitude  $P = 4.0 \text{ N}$ ) acting parallel to the surface is applied to the block. The magnitude of the block's acceleration is  $1.2 \text{ m/s}^2$ . If  $P$  is increased to 5.0 N, determine the magnitude of the block's acceleration.

- a.  $2.1 \text{ m/s}^2$   
b.  $2.3 \text{ m/s}^2$   
c.  $1.9 \text{ m/s}^2$   
d.  $1.7 \text{ m/s}^2$

ANS: D

PTS: 2

DIF: Average

$$m = 2 \text{ kg}, P - f = ma, N = mg$$

$$4 - \mu mg = ma, \mu = \frac{4 - ma}{mg}$$

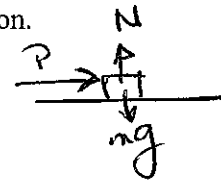

$$\mu = \frac{4 - 2.4}{2(9.8)} = 0.081$$

$$5 - \mu N = ma, a = \frac{5 - 0.081(2)(9.8)}{2} = 1.7 \text{ m/s}^2$$

e.  $3.2 \text{ m/s}^2$

ANS: D

PTS: 2

DIF: Average

69. A 4.0-kg block is pushed up a  $36^\circ$  incline by a force of magnitude  $P$  applied parallel to the incline. When  $P$  is 31 N, it is observed that the block moves up the incline with a constant speed. What value of  $P$  would be required to lower the block down the incline at a constant speed?

- a. 27 N  
 b. 15 N  
 c. 13 N  
 d. 17 N  
 e. 19 N

$$N - mg \cos \theta = 0, N = mg \cos \theta \quad (1)$$

$$P - mg \sin \theta - f = ma = 0; 31 - 4(9.8) \sin 36^\circ - \mu mg \cos \theta = 0$$

$$\mu = \frac{31 - 4(9.8) \sin 36^\circ}{4(9.8) \cos 36^\circ} = 0.25$$

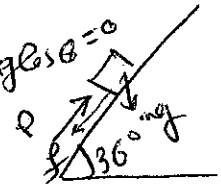

ANS: B

PTS: 2

DIF: Average

70. A 1.8-kg block is released from rest at the top of a rough  $30^\circ$  inclined plane. As the block slides down the incline, its acceleration is  $3.0 \text{ m/s}^2$  down the incline. Determine the magnitude of the force of friction acting on the block.

- a. 4.2 N  
 b. 3.0 N  
 c. 3.4 N  
 d. 3.8 N  
 e. 2.3 N

$$mg \sin \theta - f = ma, N = mg \cos \theta$$

$$mg \sin \theta - ma = f$$

$$f = m(g \sin \theta - a) = 3.42 \text{ N}$$

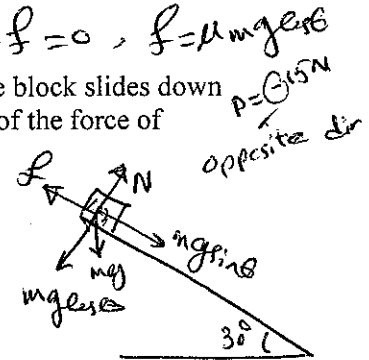

ANS: C

PTS: 2

DIF: Average

71. A 1.8-kg block is projected up a rough  $10^\circ$  inclined plane. As the block slides up the incline, its acceleration is  $3.8 \text{ m/s}^2$  down the incline. What is the magnitude of the force of friction acting on the block?

- a. 5.0 N  
 b. 3.8 N  
 c. 4.2 N  
 d. 4.6 N  
 e. 6.5 N

$$mg \sin \theta + f = ma$$

$$-f = m(g \sin \theta - a)$$

$$-f = -3.77 \text{ N}$$

$$f = 3.77 \text{ N}$$

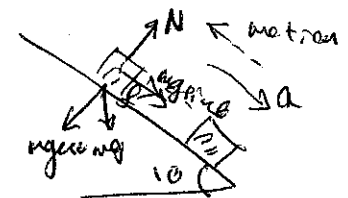

ANS: B

PTS: 2

DIF: Average

72. A 2.0-kg block slides on a rough horizontal surface. A force ( $P = 6.0 \text{ N}$ ) is applied to the block as shown. The magnitude of the block's acceleration is  $1.2 \text{ m/s}^2$ . What is the magnitude of the force of friction acting on the block?

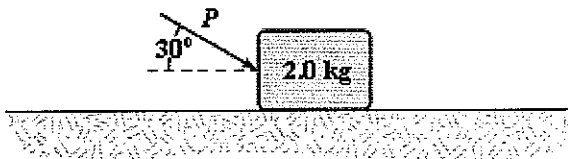

$$P \cos 30 - f = ma$$

$$6 \cos 30 - f = m(1.2)$$

$$f = 6 \cos 30 - 2(1.2)$$

$$= 2.79 \text{ N}$$

- a. 2.0 N  
 b. 1.4 N  
 c. 1.6 N  
 d. 2.8 N  
 e. 3.4 N

ANS: D

PTS: 2

DIF: Average

73. A 3.0-kg block slides on a rough horizontal surface. A force of 8.0 N acting parallel to the surface is applied to the block. The coefficient of kinetic friction between the block and the surface is 0.15. What is the magnitude of the block's acceleration?

- a. 1.9 m/s<sup>2</sup>  
 b. 1.2 m/s<sup>2</sup>  
 c. 2.3 m/s<sup>2</sup>  
 d. 1.5 m/s<sup>2</sup>  
 e. 2.9 m/s<sup>2</sup>

$$8 - f = ma, \quad N = mg$$

$$8 - \mu N = ma, \quad 8 - \mu mg = ma$$

$$a = \frac{8 - \mu mg}{m} = 1.19 \text{ m/s}^2$$

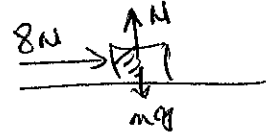

ANS: B      PTS: 2      DIF: Average

74. A 1.0-kg block is pushed up a rough 22° inclined plane by a force of 7.0 N acting parallel to the incline. The acceleration of the block is 1.4 m/s<sup>2</sup> up the incline. Determine the magnitude of the force of friction acting on the block.

- a. 1.9 N  
 b. 2.2 N  
 c. 1.3 N  
 d. 1.6 N  
 e. 3.3 N

$$7 - mg \sin \theta - f = ma$$

$$f = 7 - mg \sin \theta - ma$$

$$= 1.92 \text{ N}$$

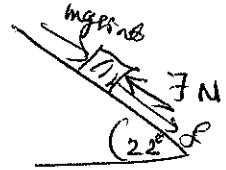

ANS: A      PTS: 2      DIF: Average

75. In the figure shown, the coefficient of kinetic friction between the block and the incline is 0.29. What is the magnitude of the acceleration of the suspended block as it falls? Disregard any pulley mass or friction in the pulley.

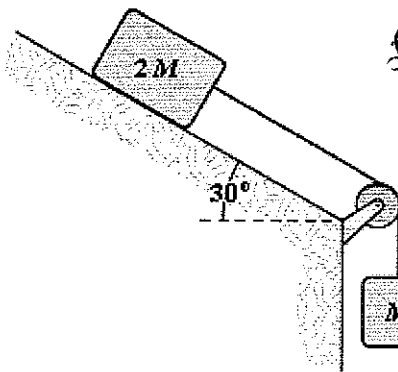

for M:  $Mg - T = Ma \rightarrow (1)$

for 2M:

$$T + 2Mg \sin \theta - f = 2Ma$$

$$f = \mu N = \mu 2Mg \cos \theta$$

$$T + 2Mg \sin \theta - 2\mu Mg \cos \theta = 2Ma \rightarrow (2)$$

$$(1) + (2):$$

$$Mg + 2Mg \sin \theta - 2\mu Mg \cos \theta = 3Ma$$

$$g + 2g \sin \theta - 2\mu g \cos \theta = 3a$$

$$a = 4.89 \text{ m/s}^2$$

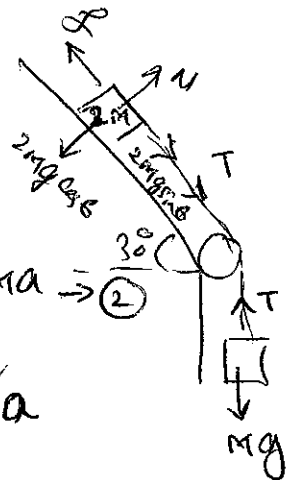

- a. 5.4 m/s<sup>2</sup>  
 b. 5.2 m/s<sup>2</sup>  
 c. 4.9 m/s<sup>2</sup>  
 d. 5.6 m/s<sup>2</sup>  
 e. 7.9 m/s<sup>2</sup>

ANS: C      PTS: 2      DIF: Average

76. In the figure shown, the coefficient of kinetic friction between the block and the incline is 0.40. What is the magnitude of the acceleration of the suspended block as it falls? Disregard any pulley mass or friction in the pulley.

for 2M:  $2Mg - T = 2Ma \rightarrow (1)$

for M:  $T - f - Mg \sin \theta = Ma \rightarrow (2)$

$$(1) + (2): 2Mg - f - Mg \sin \theta = 3Ma$$

$$f = \mu N = \mu mg \cos \theta, \text{ then}$$

$$2mg - \mu mg \cos \theta - mg \sin \theta = 3ma; \quad a = 3.43 \text{ m/s}^2$$

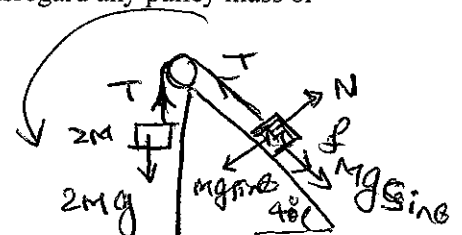

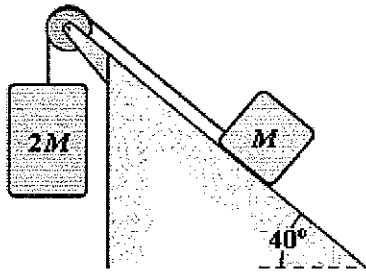

- a. 3.4 m/s<sup>2</sup>
- b. 3.7 m/s<sup>2</sup>
- c. 4.2 m/s<sup>2</sup>
- d. 3.9 m/s<sup>2</sup>
- e. 5.4 m/s<sup>2</sup>

ANS: A      PTS: 2      DIF: Average

77. The three blocks shown are released from rest and are observed to move with accelerations that have a magnitude of 1.5 m/s<sup>2</sup>. What is the magnitude of the friction force on the block that slides horizontally? Disregard any pulley mass or friction in the pulley and let M = 2.0 kg.

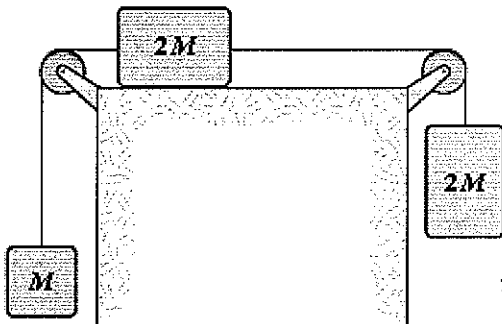

for horizontal blocks

$$T_1 - T_2 - f_k = 2Ma$$

$$f_k = T_1 - T_2 - 2Ma \rightarrow \text{①}$$

for vertical 2M

$$2Mg - T_1 = 2Ma$$

$$T_1 = 2M(g - a) \rightarrow \text{②}$$

for M:

$$T_2 - Mg = Ma \rightarrow T_2 = M(g + a) \rightarrow \text{③}$$

then from ①  $f_k = 2M(g - a) - M(g + a) - 2Ma$

$$f_k = 4.6 \text{ N}$$

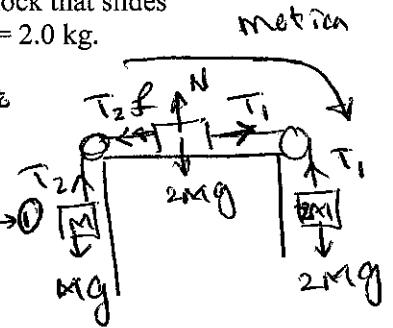

- a. 6.0 N
- b. 5.1 N
- c. 5.5 N
- d. 4.6 N
- e. 3.7 N

ANS: D      PTS: 2      DIF: Average

78. Two blocks in contact with each other are pushed to the right across a rough horizontal surface by the two forces shown. If the coefficient of kinetic friction between each of the blocks and the surface is 0.30, determine the magnitude of the force exerted on the 2.0-kg block by the 3.0-kg block.

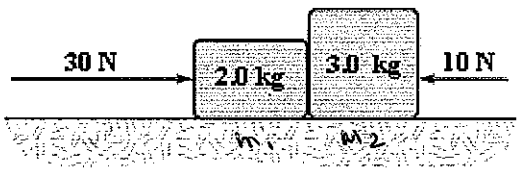

$$30 - 10 - \mu_1 m_1 g - \mu_2 m_2 g = (m_1 + m_2) a$$

$$a = \frac{20 - \mu g (m_1 + m_2)}{m_1 + m_2} = 1.06 \text{ m/s}^2$$

for m1:

$$30 - \mu N - F_{32} = m_1 a$$

$$30 - 0.3(2)(9.8) - F_{32} = 2(1.06)$$

$$F_{32} = 22 \text{ N}$$

- a. 15 N
- b. 25 N
- c. 11 N
- d. 22 N

e. 33 N

ANS: D

PTS: 2

DIF: Average

79. Two blocks are accelerated across a horizontal frictionless surface as shown. Frictional forces keep the two blocks from sliding relative to each other, and the two move with the same acceleration. If  $F = 1.2$  N and  $M = 1.0$  kg, what is the horizontal component (frictional force) of the force of the large block on the small block?

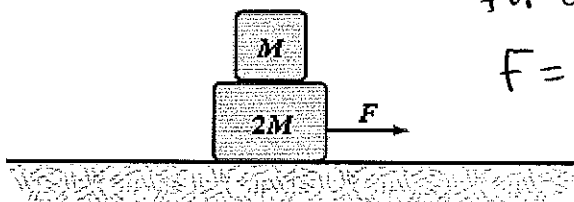

for all

$$F = 3Ma$$

$$a = \frac{1.2}{3M} \text{ m/s}^2$$

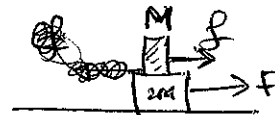

for  $M$ :  $f = Ma$

$$f = M \left( \frac{1.2}{3M} \right) = 0.4 \text{ N to the right}$$

- a. 0.40 N to the left
- b. 0.80 N to the right
- c. 0.40 N to the right
- d. 0.80 N to the left
- e. 1.20 N to the left

ANS: C

PTS: 2

DIF: Average

80. The coefficient of kinetic friction between the surface and the larger block is 0.25, and the coefficient of kinetic friction between the surface and the smaller block is 0.40. If  $F = 22$  N and  $M = 1.0$  kg in the figure, what is the magnitude of the acceleration of either block?

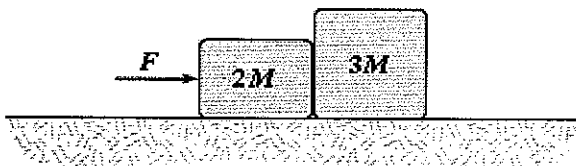

$$F - \mu_1(2Mg) - \mu_2(3Mg) = 5Ma$$

$$a = \frac{22 - 0.4(2Mg) - 0.25(3Mg)}{5} = 1.362 \text{ m/s}^2$$

- a.  $1.8 \text{ m/s}^2$
- b.  $2.6 \text{ m/s}^2$
- c.  $1.4 \text{ m/s}^2$
- d.  $2.2 \text{ m/s}^2$
- e.  $3.7 \text{ m/s}^2$

ANS: C

PTS: 2

DIF: Average

81. In the figure, the coefficient of kinetic friction between the surface and the larger block is 0.20, and the coefficient of kinetic friction between the surface and the smaller block is 0.30. If  $F = 14$  N and  $M = 1.0$  kg, what is the magnitude of the acceleration of either block?

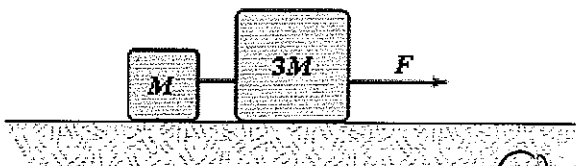

$$14 - 0.2(3Mg) - T = 3Ma \rightarrow (1)$$

$$T - 0.3(Mg) = Ma \rightarrow (2)$$

$$(1) + (2) \Rightarrow 14 - 0.2(3Mg) - 0.3(Mg) = 4Ma$$

$$a = \frac{14 - 0.2(3Mg) - 0.3(Mg)}{4M}$$

$$= 1.295 \text{ m/s}^2$$

- a.  $2.0 \text{ m/s}^2$
- b.  $1.3 \text{ m/s}^2$

- c.  $1.5 \text{ m/s}^2$
- d.  $1.8 \text{ m/s}^2$
- e.  $3.5 \text{ m/s}^2$

ANS: B

PTS: 2

DIF: Average

82. Two blocks are accelerated across a horizontal frictionless surface as shown. Frictional forces keep the two blocks from sliding relative to each other, and the two move with the same acceleration. If  $F = 1.2 \text{ N}$  and  $M = 1.0 \text{ kg}$ , what is the horizontal component (frictional force) of the force of the small block on the large block?

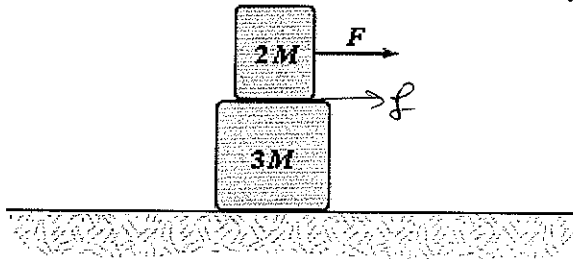

$$1.2 = (2M + 3M)a$$

$$a = \frac{1.2}{5M} \text{ m/s}^2$$

$$\text{for } 3M: f = 3Ma$$

$$f = 3Ma = 3M \left( \frac{1.2}{5M} \right)$$

$$= 0.72 \text{ to the right}$$

- a.  $0.48 \text{ N}$  to the right
- b.  $0.72 \text{ N}$  to the right
- c.  $0.72 \text{ N}$  to the left
- d.  $0.48 \text{ N}$  to the left
- e.  $0.65 \text{ N}$  to the left

ANS: B

PTS: 2

DIF: Average

83. Two blocks connected by a string are pulled across a horizontal surface by a force applied to one of the blocks, as shown. The coefficient of kinetic friction between the blocks and the surface is  $0.25$ . If each block has an acceleration of  $2.0 \text{ m/s}^2$  to the right, what is the magnitude  $F$  of the applied force?

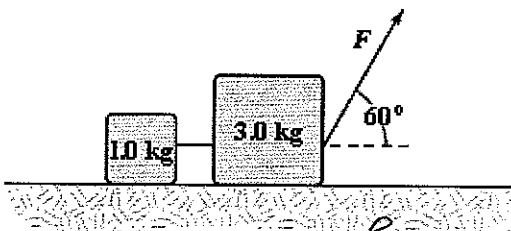

$$\text{for } 3M: F \cos 60 - f - T = 3a$$

$$F \cos 60 - \mu N - T = 3a$$

$$F \cos 60 - \mu(m_1g - F \sin 60) - T = 3a \quad (1)$$

$$\text{for } 1M: T - \mu m_1g = 1a \rightarrow (2)$$

$$(1) + (2): F \cos 60 - \mu(m_1g - F \sin 60) - \mu m_2g = 4a$$

$$F(\cos 60 + \mu \sin 60) - \mu m_1g - \mu m_2g = 4a$$

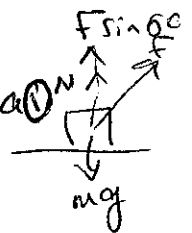

- a.  $25 \text{ N}$
- b.  $18 \text{ N}$
- c.  $11 \text{ N}$
- d.  $14 \text{ N}$
- e.  $7.0 \text{ N}$

ANS: A

PTS: 3

DIF: Challenging

$$F = 24.84 \text{ N}$$

84. In the figure, the coefficient of kinetic friction between the surface and the larger block is  $0.20$ , and the coefficient of kinetic friction between the surface and the smaller block is  $0.30$ . If  $F = 10 \text{ N}$  and  $M = 1.0 \text{ kg}$ , what is the tension in the connecting string?

$$\text{for } M: F - T - \mu Mg = Ma$$

$$10 - T - 0.3Mg = Ma \rightarrow (1)$$

$$\text{for } 2M: T - \mu 2Mg = 2Ma$$

$$T - 0.2(2Mg) = 2Ma \rightarrow (2)$$

$$(1) + (2)$$

$$10 - 0.3Mg - 0.4Mg = 3Ma$$

$$a = 1.04 \text{ m/s}^2$$

$$\text{from } (1): T = 6.02 \text{ N}$$

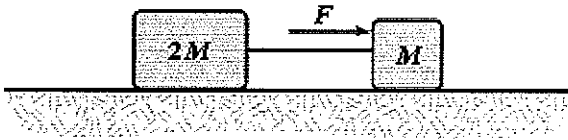

- a. 8.0 N
- b. 6.0 N
- c. 6.7 N
- d. 8.7 N
- e. 3.0 N

ANS: B

PTS: 2

DIF: Average

85. The frictional force of the floor on a large suitcase is least when the suitcase is
- a. pushed by a force parallel to the floor.
  - b. dragged by a force parallel to the floor.
  - c. pulled by a force directed at an angle  $\theta$  above the floor.
  - d. pushed by a force directed at an angle  $\theta$  into the floor.
  - e. turned on its side and pushed by a force parallel to the floor.

$$f = \mu N = \mu mg$$

ANS: C

PTS: 1

DIF: Easy

86. A 60-kg person rides down an icy hill of  $20^\circ$  slope while standing on a 3.0-kg flat-bottomed bathroom scale. Assume there is no frictional force between the bottom of the scale and the hill. The static friction force the scale exerts on the person is

- a. 0 N.
- b. 201 N.
- c. 211 N.
- d. 553 N.
- e. 580 N.

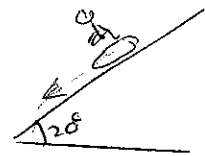

ANS: A

PTS: 1

DIF: Easy

87. A chair is placed on a rug. Then a book is placed on the chair. The floor exerts a normal force
- a. on all three.
  - b. only on the book.
  - c. only on the rug.
  - d. upwards on the rug and downwards on the chair.
  - e. only on the objects you have defined to be part of the system.

ANS: C

PTS: 1

DIF: Easy

88. Two identical springs with spring constant 50 N/m support a 5.0 N weight as in the picture below. What is the tension in spring A?

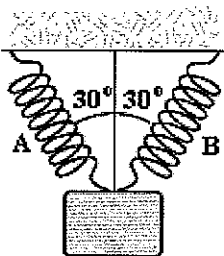

$$2T \cos 30 = 5$$

$$T = \frac{5}{2 \cos 30} = 2.89 \text{ N}$$

- a. 1.45 N

- b. 2.50 N
- c. 2.89 N
- d. 3.75 N
- e. 5.00 N

ANS: C                      PTS: 2                      DIF: Average

89. A book is placed on a chair. Then a videocassette is placed on the book. The floor exerts a normal force
- a. on all three.
  - b. only on the book.
  - c. only on the chair.
  - d. upwards on the chair and downwards on the book.
  - e. only on the objects that you have defined to be part of the system.

ANS: C                      PTS: 1                      DIF: Easy

90. Two bodies, A and B, collide as shown in Figures I and II below.

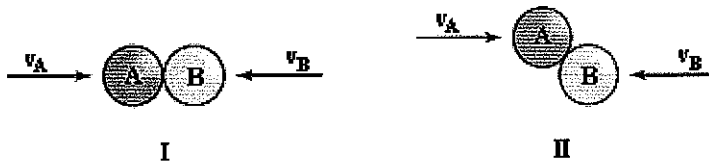

Which statement is true?

- a. They exert equal and opposite forces on each other in I but not in II.
- b. They exert equal and opposite force on each other in II but not in I.
- c. They exert equal and opposite force on each other in both I and II.
- d. The forces are equal and opposite to each other in I, but only the components of the forces parallel to the velocities are equal in II.
- e. The forces are equal and opposite in I, but only the components of the forces perpendicular to the velocities are equal in II

ANS: C                      PTS: 1                      DIF: Easy

91. You throw a ball up in the air and hold your hand under it to catch it when it comes down. The reason why the ball stops is because
- a. your hand is there: your hand exerts no force on the ball.
  - b. your hand exerts a force on the ball perpendicular to its velocity.
  - c. your hand exerts a force on the ball in the direction of its velocity.
  - d. your hand exerts a force on the ball in the direction opposite to its velocity.
  - e. your hand and the ball exert forces in the same direction on each other.

ANS: D                      PTS: 1                      DIF: Easy

92. You hold a tennis racket in your hand. On top of the racket you have balanced a ball. Which statement is true?
- a. The force of your hand on the racket and the force of the ball on the racket are equal and opposite.
  - b. The force of the racket on your hand and the force of the ball on the racket are equal and opposite.
  - c. The force of your hand on the racket and the force of the racket on the ball are equal and opposite.
  - d. The force of the racket on your hand and the force of the racket on the ball are equal and

- opposite.  
e. The force of your hand on the racket and the force of the racket on your hand are equal and opposite.

ANS: E            PTS: 1            DIF: Easy

93. When you drag a toy teddy bear along the floor by a force that is parallel to the floor, the magnitude of the force of friction

- a. is independent of velocity or acceleration.  
b. increases when the velocity increases.  
c. is proportional to the acceleration.  
d. decreases when the force parallel to the floor increases.  
e. increases when the force parallel to the floor increases.

ANS: A            PTS: 1            DIF: Easy

94. In order to jump off the floor, the floor must exert a force on you

- a. in the direction of and equal to your weight.  
b. opposite to and equal to your weight.  
c. in the direction of and less than your weight.  
d. opposite to and less than your weight.  
e. opposite to and greater than your weight.

ANS: E            PTS: 1            DIF: Easy

95. When an acrobat hangs motionless from a pair of rings

- a. she has no measurable weight.  
b. her weight depends on the angles the ropes make with the ceiling.  
c. her weight is reduced by the upward force the rings exert on her.  
d. her weight is increased by the upward force the rings exert on her.  
e. she exerts a gravitational force on the Earth that is equal to the sum of the forces the rings exert on her.

ANS: E            PTS: 1            DIF: Easy

96. Three boxes slide on a frictionless horizontal surface when pulled by a force of magnitude  $F$ . When we compare the tensions  $T_1$  and  $T_2$  with the force  $F$ , we find that



- a.  $T_1 = T_2 = F$ .  
b.  $T_1 = F > T_2$ .  
c.  $F > T_1 = T_2$ .  
d.  $F > T_1 > T_2$ .  
e.  $F - T_1 < T_1 - T_2$ .

ANS: D            PTS: 1            DIF: Easy

97. Three boxes are pushed across a frictionless horizontal surface as shown. When we compare the normal force  $N_{2,5}$  that mass  $2m$  exerts on mass  $5m$  with the normal force  $N_{5,10}$  that mass  $5m$  exerts on mass  $10m$ , we find that

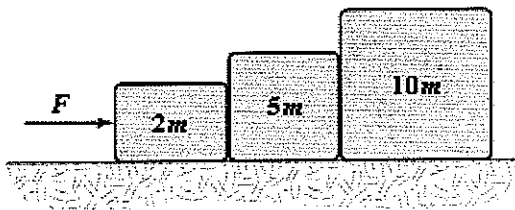

- a.  $N_{2,5} = N_{5,10} = F$ .
- b.  $N_{2,5} = F > N_{5,10}$ .
- c.  $F > N_{2,5} = N_{5,10}$ .
- d.  $F > N_{2,5} > N_{5,10}$ .
- e.  $F > N_{5,10} > N_{2,5}$ .

ANS: D

PTS: 1

DIF: Easy

98. Given the equation  $(2.00 \text{ kg}) \left( 5.00 \frac{\text{m}}{\text{s}^2} \right) = 20.00 \text{ N} - 10.00 \text{ N}$ , which answer or answers provide(s) the best description of a possible physical situation?
- a. A 20.00 N tension pulls a 2.00 kg mass. The 2.00 kg mass pulls another 2.00 kg mass.
  - b. A 20.00 N force pushes a 2.00 kg mass. The 2.00 kg mass pushes another 2.00 kg mass.
  - c. A 2.00 kg mass on a flat surface is acted on by gravity while another 2.00 kg mass sits on top of it.
  - d. All of the situations above are possible.
  - e. Only (a) and (b) above are possible.

ANS: E

PTS: 2

DIF: Average

99. Given the equation  $(3.00 \text{ kg}) \left( 5.88 \frac{\text{m}}{\text{s}^2} \right) = (3.00 \text{ kg}) \left( 9.80 \frac{\text{m}}{\text{s}^2} \right) - (2.00 \text{ kg}) \left( 5.88 \frac{\text{m}}{\text{s}^2} \right)$ , which answer provides the best description of a possible physical situation?
- a. A 3.00 kg mass is suspended from the ceiling.
  - b. A 2.00 kg mass hanging over a pulley drags a 3.00 kg mass along a frictionless horizontal surface.
  - c. A 3.00 kg mass hanging over a pulley drags a 2.00 kg mass along a frictionless horizontal surface.
  - d. A 3.00 kg mass hanging over a pulley drags a 5.00 kg mass along a frictionless horizontal surface.
  - e. A 5.00 kg mass hanging over a pulley drags a 3.00 kg mass along a frictionless horizontal surface.

ANS: C

PTS: 2

DIF: Average

100. Two experiments are performed. In (A), an 18.0 N force pushes horizontally on a 2.00 kg block that then pushes on a 4.00 kg block. In (B), an 18.0 N force pushes on a 4.00 kg block that then pushes on a 2.00 kg block. Which statement is correct?
- a. The acceleration is  $3.00 \text{ m/s}^2$  in both (A) and (B).
  - b. The acceleration is  $4.50 \text{ m/s}^2$  in both (A) and (B).
  - c. The acceleration is  $6.00 \text{ m/s}^2$  in both (A) and (B).
  - d. The acceleration is  $9.00 \text{ m/s}^2$  in both (A) and (B).
  - e. The 2.00 kg block has a  $9.00 \text{ m/s}^2$  acceleration. The 4.00 kg block has a  $4.50 \text{ m/s}^2$  acceleration.

ANS: A

PTS: 1

DIF: Easy

101. A catcher arranges to catch a baseball dropped from a height 50 m above his glove. However, his friends substitute a soft 250 g red grapefruit, so that it will smash apart when he catches it. His glove stops the grapefruit in 0.010 s. What force does the glove exert on the grapefruit?
- 0.078 3 N
  - 783 N
  - 2 450 N
  - 24 500 N
  - 78 300 N

$$v^2 = v_i^2 + 2gh, \quad v = \sqrt{2(9.8)(50)} \text{ m/s}$$

$$a = \frac{0 - v_i}{0.01} \quad ; \quad F = ma = \frac{0.25 \times \sqrt{2(9.8)(50)}}{0.01}$$

$$= 782.6 \text{ N}$$

ANS: B      PTS: 2      DIF: Average

**Exhibit 5-1**

A 2.30 kg mass is suspended from the ceiling and a 1.70 kg mass is suspended from the 2.30 kg mass, as shown. The tensions in the strings are labeled  $\vec{T}_1$  and  $\vec{T}_2$ .

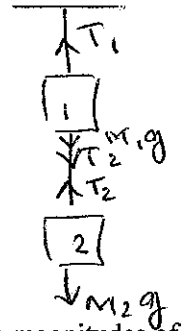
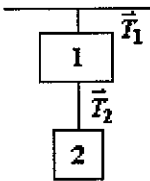

Use this exhibit to answer the following question(s).

102. Refer to Exhibit 5-1. A hand exerts an upward force of 6.70 N on the 1.70 kg mass. The magnitudes of the tensions are
- $T_1 = 15.8 \text{ N}; T_2 = 10.0 \text{ N}$ .
  - $T_1 = 15.8 \text{ N}; T_2 = 16.7 \text{ N}$ .
  - $T_1 = 22.5 \text{ N}; T_2 = 10.0 \text{ N}$ .
  - $T_1 = 22.5 \text{ N}; T_2 = 16.7 \text{ N}$ .
  - $T_1 = 32.5 \text{ N}; T_2 = 10.0 \text{ N}$ .

$$\begin{aligned} T_1 - M_1g - T_2 &= 0 \\ T_1 - 2.30g - T_2 &= 0 \rightarrow (1) \\ R + T_2 - M_2g &= 0 \rightarrow (2) \\ (1) + (2) \quad T_1 - 2.3g + R - 1.7g &= 0 \\ T_1 &= (2.3 + 1.7)(9.8) - R = 32.5 \text{ N} \end{aligned}$$

ANS: E      PTS: 2

DIF: Average

103. Refer to Exhibit 5-1. The string supporting the 1.70 kg mass is cut. The magnitudes of the tension in string 1 before and after string 2 is cut are

- $T_{1,b} = 22.5 \text{ N}; T_{1,f} = 5.80 \text{ N}$ .
- $T_{1,b} = 39.2 \text{ N}; T_{1,f} = 5.80 \text{ N}$ .
- $T_{1,b} = 22.5 \text{ N}; T_{1,f} = 22.5 \text{ N}$ .
- $T_{1,b} = 39.2 \text{ N}; T_{1,f} = 22.5 \text{ N}$ .
- $T_{1,b} = 39.2 \text{ N}; T_{1,f} = 39.2 \text{ N}$ .

$$\begin{aligned} \text{before } T_1 - m_1g - T_2 &= 0 \quad (1) \quad \text{from } (2) \quad T_2 = 9.96 \text{ N} \\ T_2 - m_2g &= 0 \quad (2) \\ (1) + (2) \quad T_1 &= (m_1 + m_2)g = 39.2 \text{ N} \\ \text{After } T_1 - m_1g &= 0 \rightarrow T_1 = m_1g \\ &= (2.3)(9.8) = 22.54 \text{ N} \end{aligned}$$

ANS: D      PTS: 2

DIF: Average

104. A 6.00 kg block is placed on a  $30.0^\circ$  incline and connected to another block on a  $36.87^\circ$  incline. Although the surfaces are frictionless the blocks do not move. What is the mass in kilograms of the block on the  $36.87^\circ$  incline?

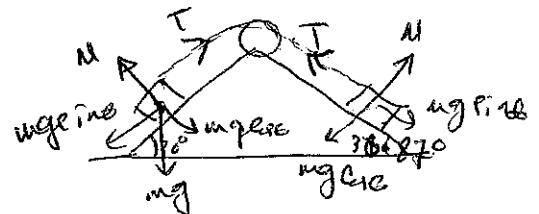
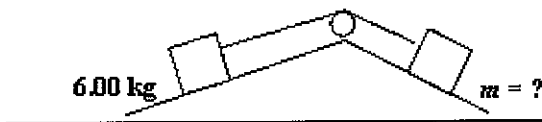

- 1.80
- 3.00

$$\begin{aligned} \text{for } m: \quad mg \sin \theta - T &= 0 \\ m &= \frac{T}{g \sin \theta} \rightarrow (1) \end{aligned}$$

$$\text{for } 6 \text{ kg: } T - mg \sin \theta = 0$$

$$T = mg \sin \theta = 6(9.8) \sin 30 = 29.4 \text{ N}$$

- c. 4.00
- d. 5.00
- e. 6.00

then ①

$$m = \frac{29.4}{9.8 \sin(36.87)} = 4.99 \text{ kg}$$

ANS: D

PTS: 2

DIF: Average

**Exhibit 5-2**

A 4.00 kg block is suspended from the roof of an elevator. A 2.00 kg block is suspended from the 4.00 kg block. The tensions in strings 1 and 2 are labeled  $\vec{T}_1$  and  $\vec{T}_2$ .

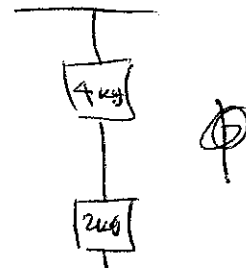
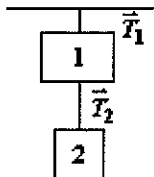

Use this exhibit to answer the following question(s).

105. Refer to Exhibit 5-2. When the elevator accelerates upwards with an acceleration of  $2.20 \text{ m/s}^2$ , the magnitudes of  $\vec{T}_1$  and  $\vec{T}_2$  are
- for  $4 \text{ kg}$ :  $T_1 - T_2 - 4(9.8) = 4(2.20) \rightarrow \textcircled{1}$   
 for  $2 \text{ kg}$ :  $T_2 - 2(9.8) = 2(2.20)$   
 then  $T_2 = 2(9.8 + 2.2)$   
 from ①  $T_1 = T_2 + 4(9.8) + 4(2.2) = 72 \text{ N}$
- a. 30.4 N; 15.2 N.
  - b. 39.2 N; 19.6 N.
  - c. 45.6 N; 15.2 N.
  - d. 48.0 N; 24.0 N.
  - e. 72.0 N; 24.0 N.

ANS: E

PTS: 2

DIF: Average

106. Refer to Exhibit 5-2. When the elevator accelerates downwards with an acceleration of  $2.20 \text{ m/s}^2$ , the magnitudes of  $\vec{T}_1$  and  $\vec{T}_2$  are
- for  $4 \text{ kg}$ :  $T_2 + 4(9.8) - T_1 = 4(2.2) \rightarrow \textcircled{1}$   
 for  $2 \text{ kg}$ :  $2(9.8) - T_2 = 2(2.2)$   
 $T_2 = 2(9.8 - 2.2) = 15.2 \text{ N}$   
 from ①  $T_1 = 4(2.2) + T_2 + 4(9.8) = 45.6 \text{ N}$
- a. 30.4 N; 15.2 N.
  - b. 39.2 N; 19.6 N.
  - c. 45.6 N; 15.2 N.
  - d. 48.0 N; 24.0 N.
  - e. 72.0 N; 24.0 N.

ANS: C

PTS: 2

DIF: Average

107. Aline and Charlie are arguing as to whether or not it is possible in principle for an elevator to have an acceleration of magnitude greater than  $g$ . In the course of their discussion they come up with the statements below. Which one is correct?
- a. No, because once  $|\vec{a}|$  reaches  $g$ , the elevator is in free fall.
  - b. No, because an acceleration greater than  $g$  is not possible.
  - c. Yes, because it can reach an acceleration greater than  $g$  when the cable breaks.
  - d. Yes, because it can reach an acceleration greater than  $g$  if the motor is strong enough.
  - e. No, because it cannot exceed its terminal acceleration.

ANS: D

PTS: 1

DIF: Easy

108. Which type of force would be the equal and opposite force to a gravitational force?
- a. gravitational
  - b. electromagnetic
  - c. strong

- d. weak  
e. It could be any one of the above or some combination of them.

ANS: A                      PTS: 1                      DIF: Easy

109. A book is resting on a table. How many forces would be in the free-body diagram of the book?  
a. one  
b. two of the same type  
c. two of different types  
d. three or more of the same type  
e. three or more of at least two different types

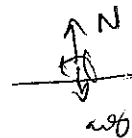

ANS: C                      PTS: 1                      DIF: Easy

110. Which of the following is not a fundamental force?  
a. the gravitational force  
b. the electromagnetic force  
c. the strong force  
d. the force of forward motion also known as the inertial force  
e. Choose this answer if two of the named forces are not fundamental.

ANS: D                      PTS: 1                      DIF: Easy

111. An object on the flat bed of a truck that is accelerating along a straight horizontal road. The coefficient of static friction is 0.300 in this case. Of the following choices, which is the lowest value of acceleration that would result in the object sliding on the bed of the truck?

- a. 0.280 m/s<sup>2</sup>  
b. 0.310 m/s<sup>2</sup>  
c. 2.93 m/s<sup>2</sup>  
d. 2.99 m/s<sup>2</sup>  
e. 3.02 m/s<sup>2</sup>

$$f_s = ma$$

$$\mu_s N = ma$$

$$\mu_s mg = ma, a = \mu_s g$$

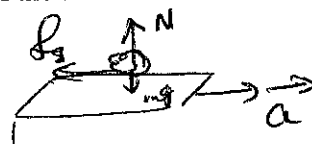

ANS: D                      PTS: 2                      DIF: Average

**PROBLEM**

112. A high-diver of mass 70.0 kg jumps off a board 10.0 m above the water. If, two seconds after entering the water, his downward motion is stopped, what average upward force did the water exert on him?

ANS:  
1180 N

water:  $mg - f_w = ma, f_w = mg - ma \rightarrow \text{①}$   
air:  $v^2 = v_0^2 + 2g\Delta y, v^2 = 0 + 2(9.8)(10), v = 14 \text{ m/s}$

PTS: 2

DIF: Average

water:  $v = v_0 + at, 0 = 14 + a(2)$   
 $a = -7 \text{ m/s}^2, \text{ from ① } f_w = 1176 \text{ N}$

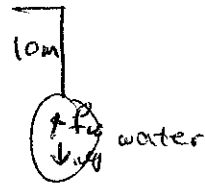

113. A 2000-kg sailboat experiences an eastward force of 3000 N by the ocean tide and a wind force against its sails of magnitude 6000 N directed toward the northwest (45° N of W). What is the magnitude and direction of the resultant acceleration?

ANS:  
2.2 m/s<sup>2</sup> at 74° N of W

$$F_x = 3000 - 6000 \cos 45^\circ, F_y = 6000 \sin 45^\circ = 4242.6 \text{ N}$$



PTS: 3

DIF: Challenging

$$F = \sqrt{F_x^2 + F_y^2} = ma = 2000 a$$

$$a = 2.2 \text{ m/s}^2, \tan \theta = \frac{a_y}{a_x} = \frac{F_y}{F_x}$$

$$\tan \theta = \frac{F_y}{F_x}, \theta = 74^\circ$$

114. A box is dropped onto a conveyor belt moving at 2 m/s. If the coefficient of friction between the box and the belt is 0.3, how long before the box moves without slipping?

ANS:

0.7 s

PTS: 2

DIF: Average

$$-f = ma$$

$$-\mu mg = ma, \quad a = -\mu g$$

$$v = v_0 + at$$

$$0 = 2 - \mu g t$$

$$t = \frac{2}{\mu g} = \frac{2}{0.3(9.8)} = \underline{\underline{0.68 \text{ s}}}$$