

**CVG 2140 – Solution to Assignment No. 2 (SFD/BMD/Trusses)**

**Problem 1.** Determine the forces in all members of the truss shown in Fig. 1.

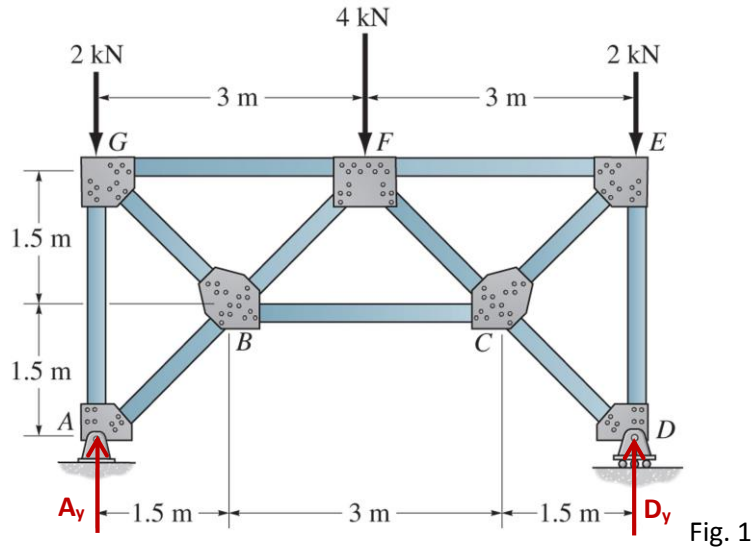

Since the truss has symmetry in geometry, boundary conditions (supports) and loading, only half of it will be solved; the other half will be the same. By establishing equilibrium (moments are assumed positive counterclockwise), the external reactions at the supports are:

$$\left. \begin{aligned} \sum F_y &= A_y - 2 - 4 - 2 + D_y = 0 \\ \sum M_A &= -(4 \times 3) - (2 \times 6) + (D_y \times 6) = 0 \end{aligned} \right\} \Rightarrow \begin{aligned} A_y &= 4 \text{ kN} \\ D_y &= 4 \text{ kN} \end{aligned}$$

The internal forces along each truss member are solved using the method of joints.

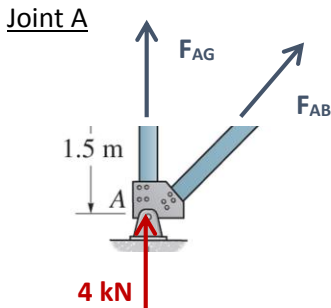

$$\left. \begin{aligned} \sum F_x &= \frac{1.5}{\sqrt{4.5}} F_{AB} = 0 \\ \sum F_y &= 4 + F_{AG} + \frac{1.5}{\sqrt{4.5}} F_{AB} = 0 \end{aligned} \right\} \Rightarrow \begin{aligned} F_{AB} &= 0 \text{ kN} \\ F_{AG} &= -4 \text{ kN (C)} \end{aligned}$$

### Joint G

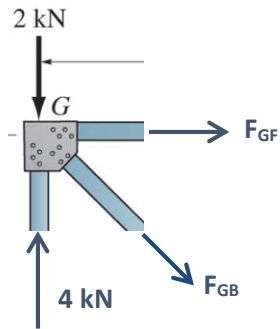

$$\left. \begin{aligned} \sum F_x &= F_{GF} + \frac{1.5}{\sqrt{4.5}} F_{GB} = 0 \\ \sum F_y &= 4 - 2 - \frac{1.5}{\sqrt{4.5}} F_{GB} = 0 \end{aligned} \right\} \Rightarrow \begin{aligned} F_{GF} &= -2.0 \text{ kN (C)} \\ F_{GB} &= 2.83 \text{ kN (T)} \end{aligned}$$

### Joint B

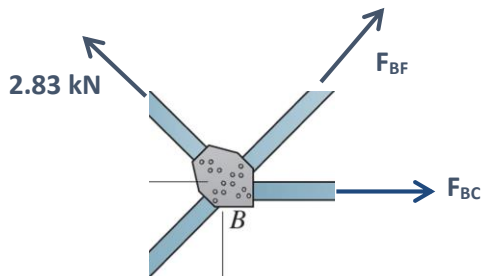

$$\left. \begin{aligned} \sum F_x &= F_{BC} + \frac{1.5}{\sqrt{4.5}} F_{BF} - \left( \frac{1.5}{\sqrt{4.5}} \times 2.83 \right) = 0 \\ \sum F_y &= \frac{1.5}{\sqrt{4.5}} F_{BF} + \left( \frac{1.5}{\sqrt{4.5}} \times 2.83 \right) = 0 \end{aligned} \right\} \Rightarrow \begin{aligned} F_{BF} &= -2.83 \text{ kN (C)} \\ F_{BF} &= 4 \text{ kN (T)} \end{aligned}$$

The internal forces of all members are summarized in the following figure:

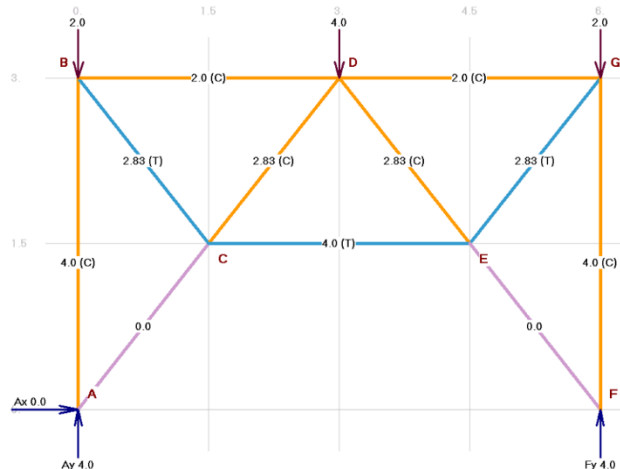

**Problem 2.** For the cantilever beam shown in Fig. 2, draw the shear force and bending moment diagrams.

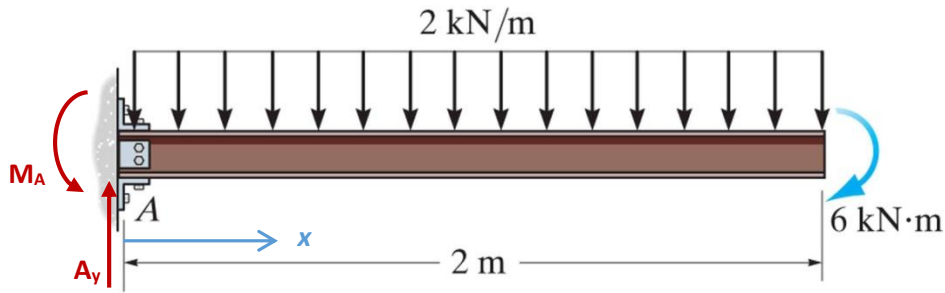
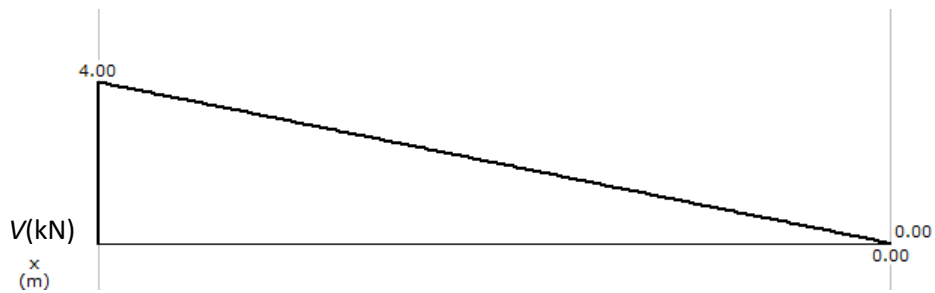

Fig. 2

By establishing equilibrium (moments are assumed positive counterclockwise):

$$\left. \begin{aligned} \sum F_y = A_y - (2 \times 2) &= 0 \\ \sum M_A = M_A - (2 \times 2 \times 1) - 6 &= 0 \end{aligned} \right\} \Rightarrow \begin{aligned} A_y &= 4 \text{ kN} \\ M_A &= 10 \text{ kN} \cdot \text{m} \end{aligned}$$

The shear force diagram for the cantilever beam in Fig. 2 is shown below:



The bending moment diagram for the cantilever beam in Fig. 2 is shown below:

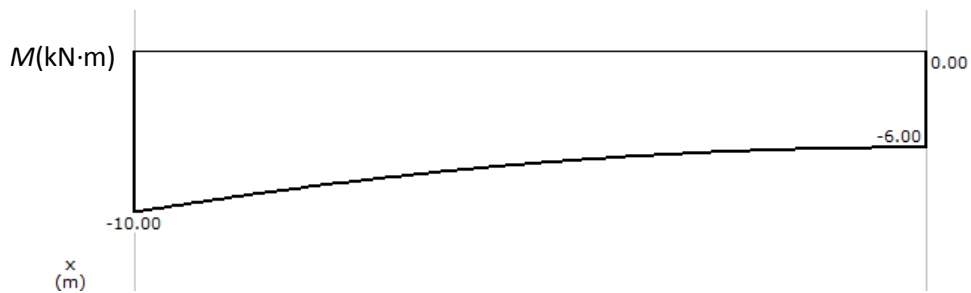

**Problem 3.** Draw the shear force and bending moment diagrams for the beam shown in Fig. 3.

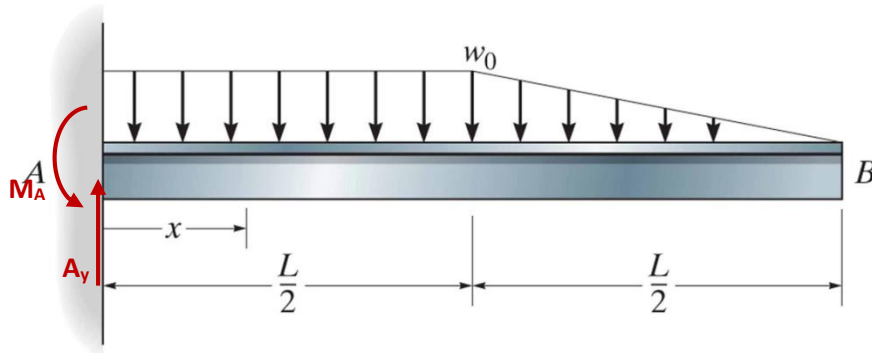
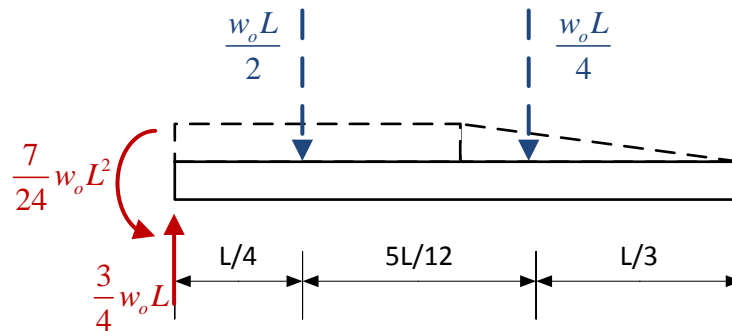

Fig. 3

By establishing equilibrium (moments are assumed positive counterclockwise):

$$\left. \begin{aligned} \sum F_y = A_y - \left( w_0 \times \frac{L}{2} \right) - \left( \frac{1}{2} \times w_0 \times \frac{L}{2} \right) &= 0 \\ \sum M_A = M_A - \left( w_0 \times \frac{L}{2} \times \frac{L}{4} \right) - \left[ \frac{1}{2} \times w_0 \times \frac{L}{2} \times \left( \frac{L}{2} + \frac{1}{3} \cdot \frac{L}{2} \right) \right] &= 0 \end{aligned} \right\} \Rightarrow \begin{aligned} A_y &= \frac{3}{4} w_0 L \\ M_A &= \frac{7}{24} w_0 L^2 \end{aligned}$$



The shear force diagram for the cantilever beam in Fig. 3 is shown below:

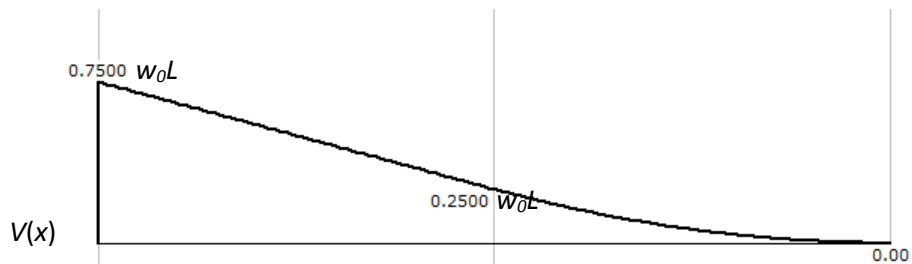

The bending moment diagram for the cantilever beam in Fig. 3 is shown below:

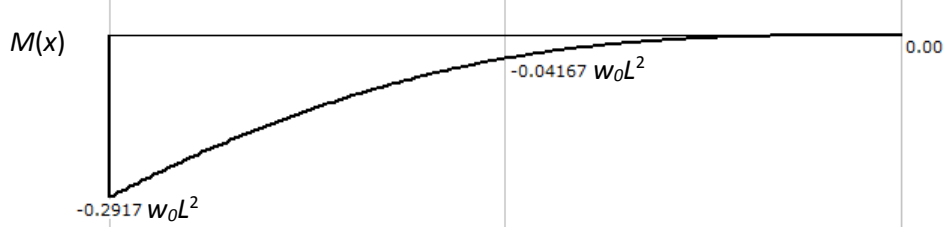

**Problem 4.** Draw the shear force and bending moment diagrams for the compound beam illustrated in Fig. 4.

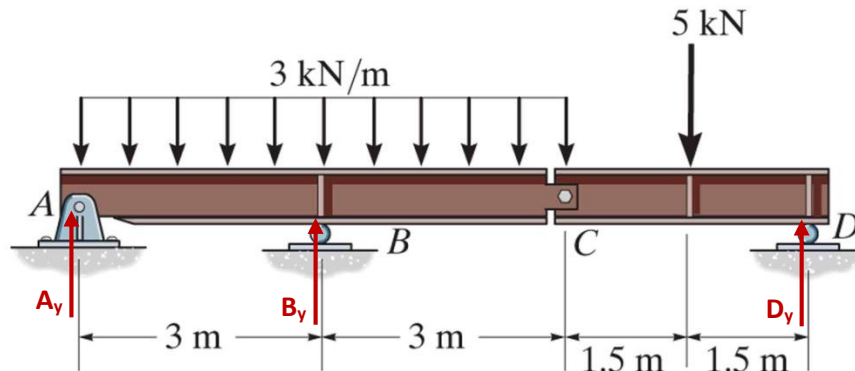

Fig. 4

By establishing equilibrium on segment  $CD$  (moments are assumed positive counterclockwise):

$$\left. \begin{aligned} \sum F_y = C_y + D_y - 5 &= 0 \\ \sum M_C = -(5 \times 1.5) + (D_y \times 3) &= 0 \end{aligned} \right\} \Rightarrow \begin{aligned} C_y &= 2.5 \text{ kN} \\ D_y &= 2.5 \text{ kN} \end{aligned}$$

Likewise, by establishing equilibrium on segment  $ABC$ :

$$\left. \begin{aligned} \sum F_y = A_y + B_y - (3 \times 6) - C_y &= 0 \\ \sum M_A = -(3 \times 6 \times 3) + (B_y \times 3) - (C_y \times 6) &= 0 \end{aligned} \right\} \Rightarrow \begin{aligned} A_y &= -2.5 \text{ kN} \\ B_y &= 23 \text{ kN} \end{aligned}$$

The shear force diagram for the compound beam in Fig. 4 is shown below:

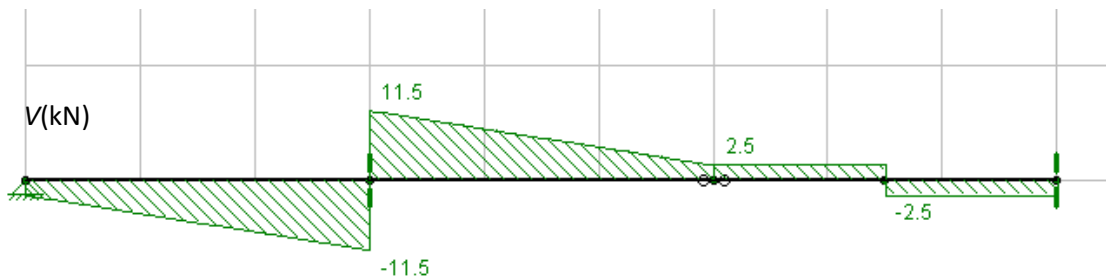

The bending moment diagram for the compound beam in Fig. 4 is shown below:

