

CVG2140 – Assignment No. 4 (Axial Members)

(Due Date: Monday, Feb. 23rd, 2015 by 5 PM)

Problem 1. The A-36 steel rod ($E = 200 \text{ GPa}$) is subjected to the loading shown in Fig. 1. If the cross-sectional area of the rod is 50 mm^2 , determine the displacement of its end D . Neglect the size of the couplings at B , C , and D .

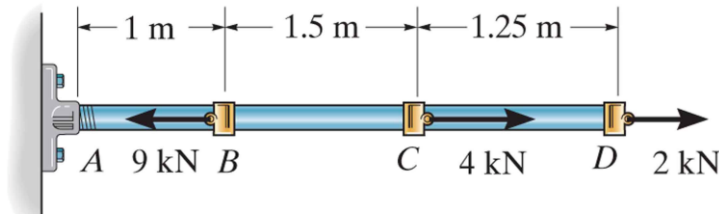

Fig. 1

Problem 2. The assembly consists of two A-36 steel rods and a rigid bar BD . Each rod has a diameter of 0.75 in. If a force of 10 kip is applied to the bar as shown in Fig. 2, determine the vertical displacement of the load. $E_{st} = 29,000 \text{ ksi}$.

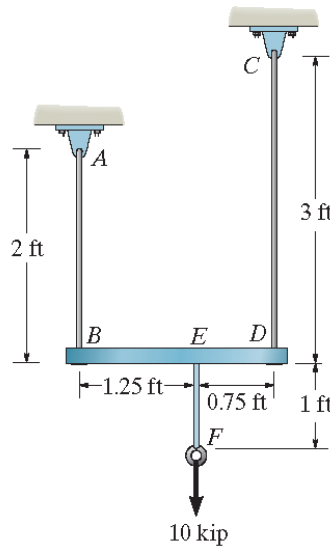

Fig. 2

Problem 3. The composite bar in Fig. 3 consists of a 20-mm diameter A-36 steel segment AB and 50-mm-diameter red brass C83400 end segments DA and CB . Determine the displacement of A with respect to B due to the applied load. $E_{st} = 200 \text{ GPa}$, $E_{br} = 101 \text{ GPa}$.

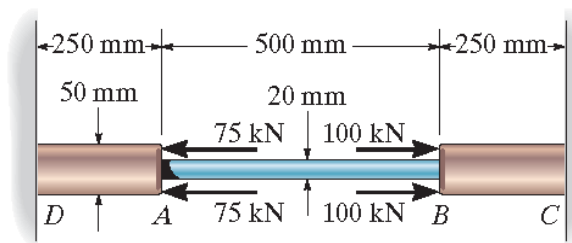

Fig. 3

Problem 4. The concrete post in Fig. 4 is reinforced using six steel reinforcing rods, each having a diameter of 20 mm. Determine the stress in the concrete and the steel reinforcing bars if the post is subjected to an axial load of 900 kN. $E_{st} = 200$ GPa and $E_c = 25$ GPa.

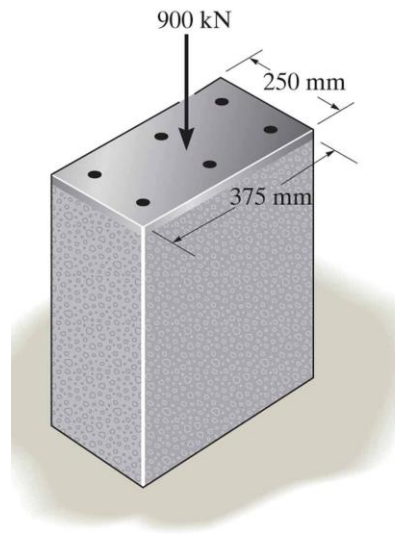

Fig. 4