

Chapter 4

Equilibrium of Rigid Bodies

Contents

[Introduction](#)

[Free-Body Diagram](#)

[Reactions at Supports and Connections
for a Two-Dimensional Structure](#)

[Equilibrium of a Rigid Body in Two
Dimensions](#)

[Statically Indeterminate Reactions](#)

[Sample Problem 4.1](#)

[Sample Problem 4.3](#)

[Sample Problem 4.4](#)

[Equilibrium of a Two-Force Body](#)

[Equilibrium of a Three-Force Body](#)

[Sample Problem 4.6](#)

[Equilibrium of a Rigid Body in Three
Dimensions](#)

[Reactions at Supports and Connections for a
Three-Dimensional Structure](#)

[Sample Problem 4.8](#)

Introduction

- For a rigid body in static equilibrium, the external forces and moments are balanced and will impart no translational or rotational motion to the body.
- The necessary and sufficient condition for the static equilibrium of a body are that the resultant force and couple from all external forces form a system equivalent to zero,

$$\sum \vec{F} = 0 \quad \sum \vec{M}_O = \sum (\vec{r} \times \vec{F}) = 0$$

- Resolving each force and moment into its rectangular components leads to 6 scalar equations which also express the conditions for static equilibrium,

$$\begin{aligned} \sum F_x = 0 & \quad \sum F_y = 0 & \quad \sum F_z = 0 \\ \sum M_x = 0 & \quad \sum M_y = 0 & \quad \sum M_z = 0 \end{aligned}$$

Free-Body Diagram

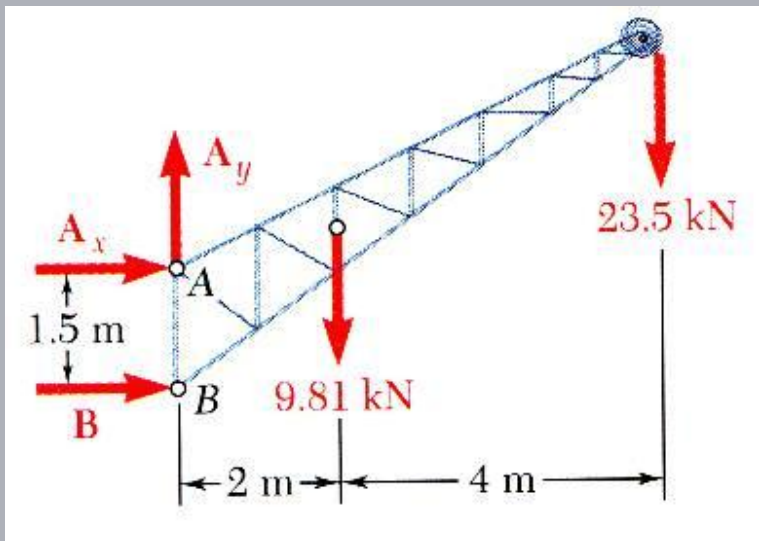
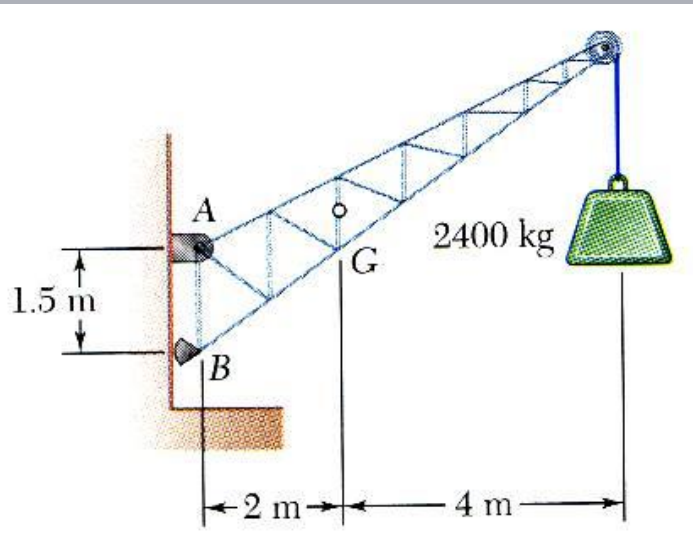

First step in the static equilibrium analysis of a rigid body is identification of all forces acting on the body with a *free-body* diagram.

- Select the extent of the free-body and detach it from the ground and all other bodies.
- Indicate point of application, magnitude, and direction of external forces, including the rigid body weight.
- Indicate point of application and assumed direction of unknown applied forces. These usually consist of reactions through which the ground and other bodies oppose the possible motion of the rigid body.
- Include the dimensions necessary to compute the moments of the forces.

Reactions at Supports and Connections for a Two-Dimensional Structure

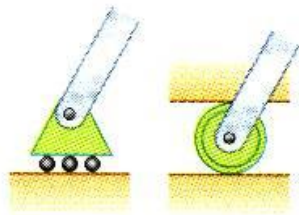

Rollers



Rocker

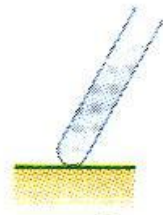

Frictionless surface



Force with known line of action

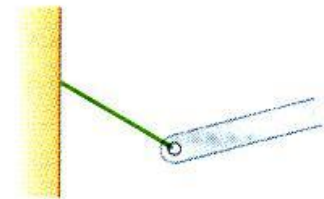

Short cable

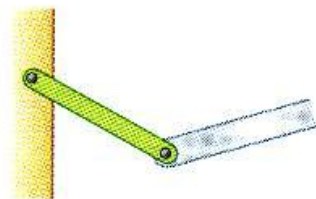

Short link



Force with known line of action

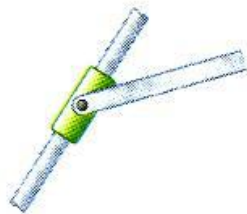

Collar on frictionless rod

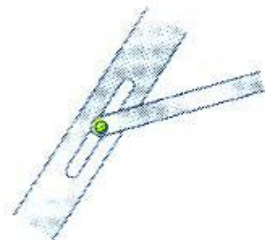

Frictionless pin in slot

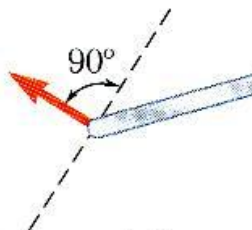

Force with known line of action

- Reactions equivalent to a force with known line of action.

Reactions at Supports and Connections for a Two-Dimensional Structure

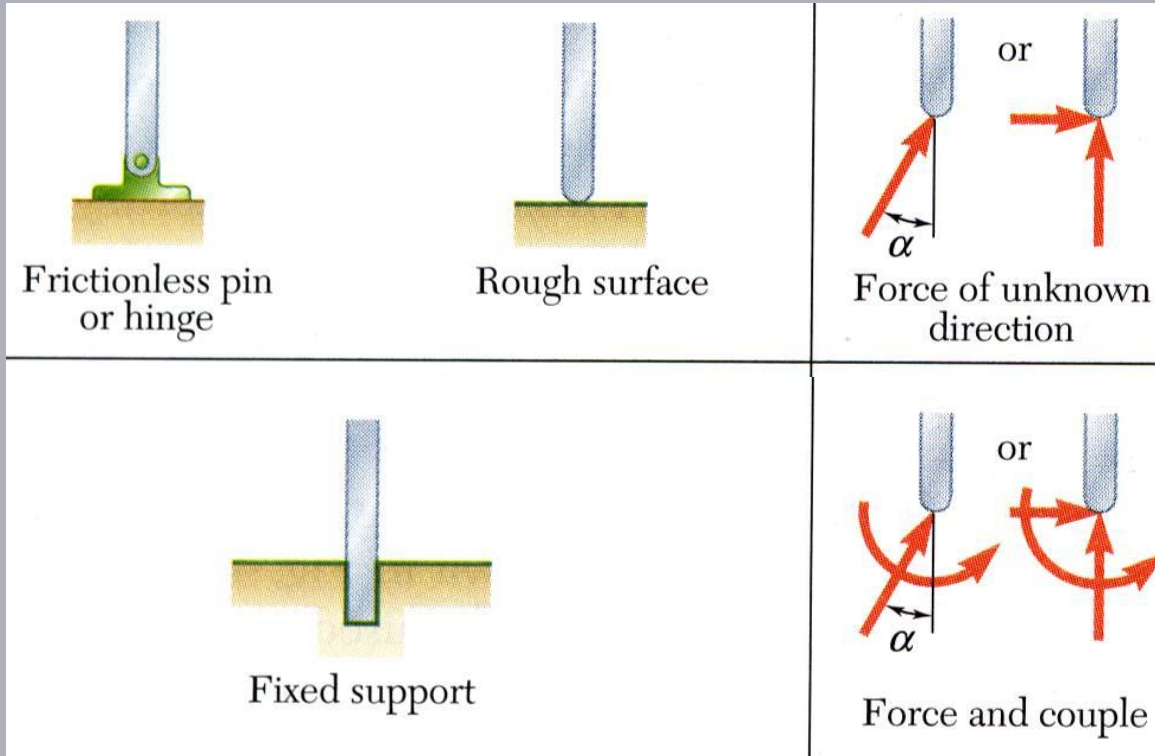

- Reactions equivalent to a force of unknown direction and magnitude.
- Reactions equivalent to a force of unknown direction and magnitude and a couple of unknown magnitude

Equilibrium of a Rigid Body in Two Dimensions

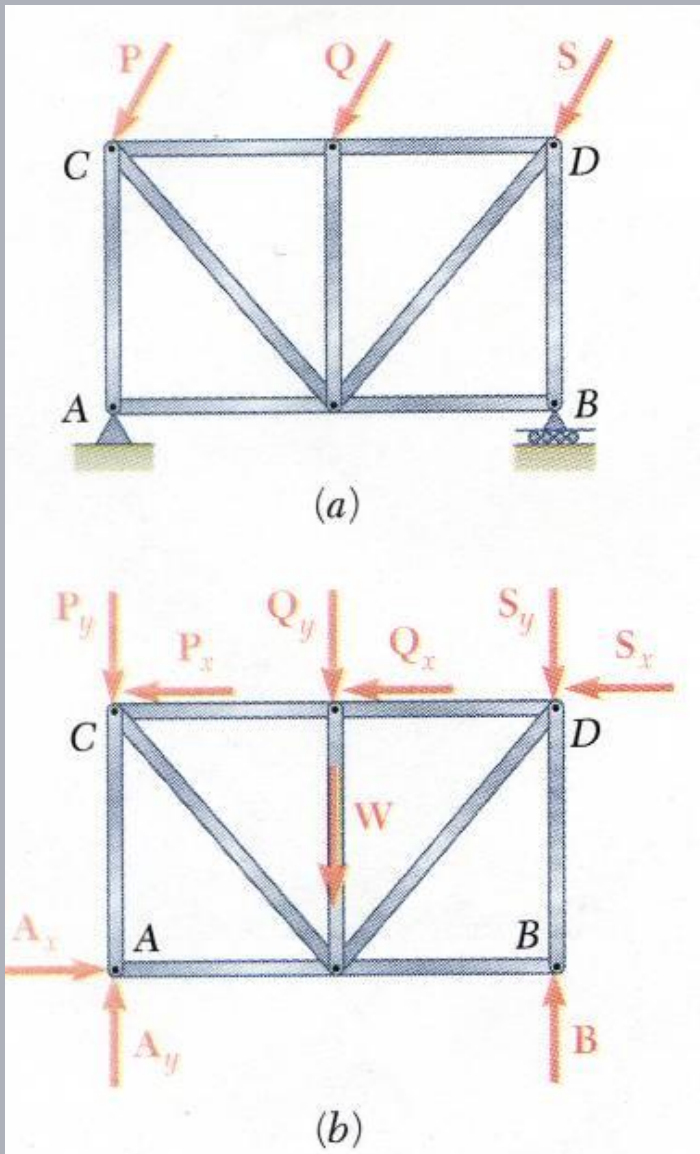

- For all forces and moments acting on a two-dimensional structure,

$$F_z = 0 \quad M_x = M_y = 0 \quad M_z = M_O$$

- Equations of equilibrium become

$$\sum F_x = 0 \quad \sum F_y = 0 \quad \sum M_A = 0$$

where A is any point in the plane of the structure.

- The 3 equations can be solved for no more than 3 unknowns.
 - The 3 equations can not be augmented with additional equations, but they can be replaced
- $$\sum F_x = 0 \quad \sum M_A = 0 \quad \sum M_B = 0$$

Statically Indeterminate Reactions

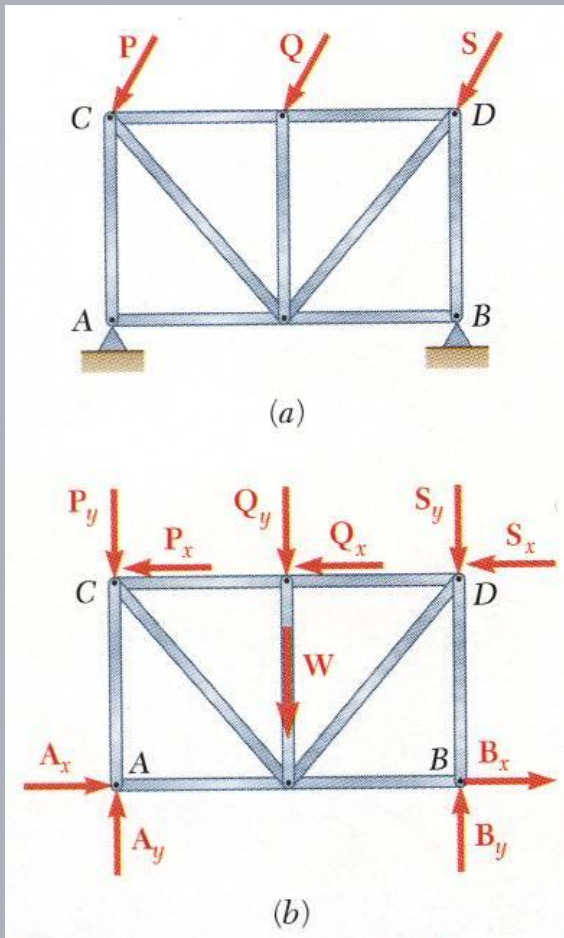

- More unknowns than equations

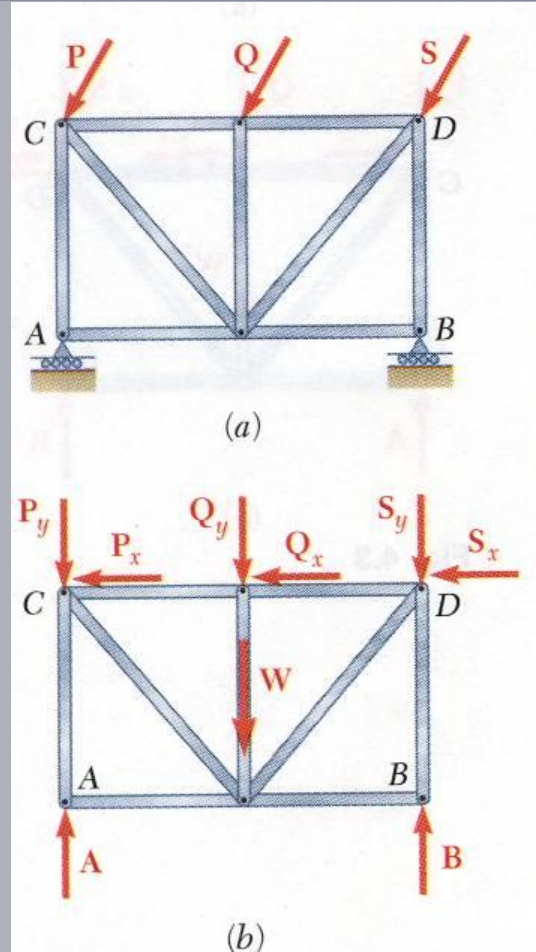

- Fewer unknowns than equations, partially constrained

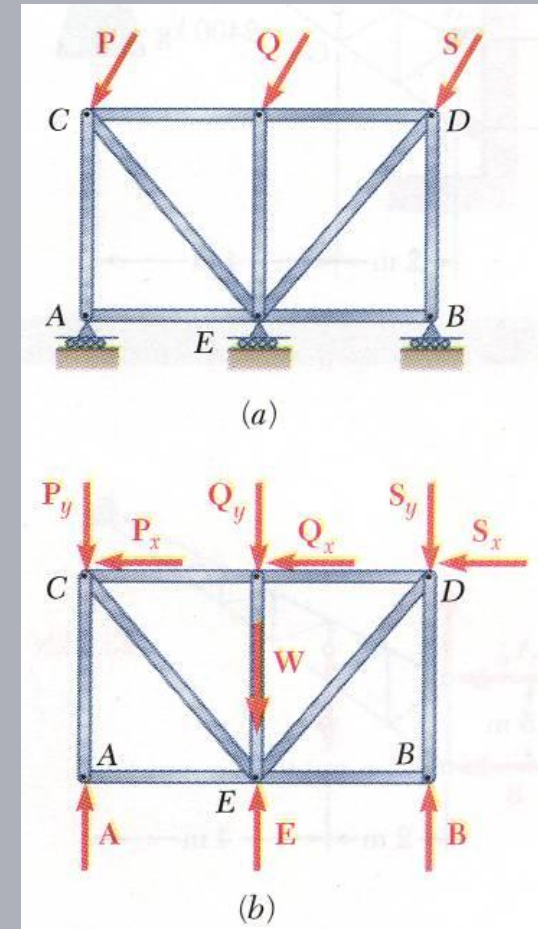

- Equal number unknowns and equations but improperly constrained

Sample Problem 4.1

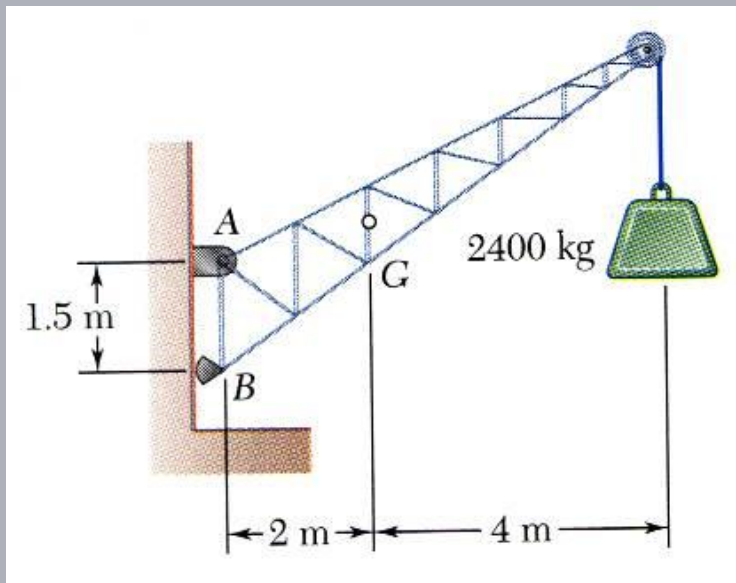

A fixed crane has a mass of 1000 kg and is used to lift a 2400 kg crate. It is held in place by a pin at A and a rocker at B . The center of gravity of the crane is located at G .

Determine the components of the reactions at A and B .

SOLUTION:

- Create a free-body diagram for the crane.
- Determine B by solving the equation for the sum of the moments of all forces about A . Note there will be no contribution from the unknown reactions at A .
- Determine the reactions at A by solving the equations for the sum of all horizontal force components and all vertical force components.
- Check the values obtained for the reactions by verifying that the sum of the moments about B of all forces is zero.

Sample Problem 4.1

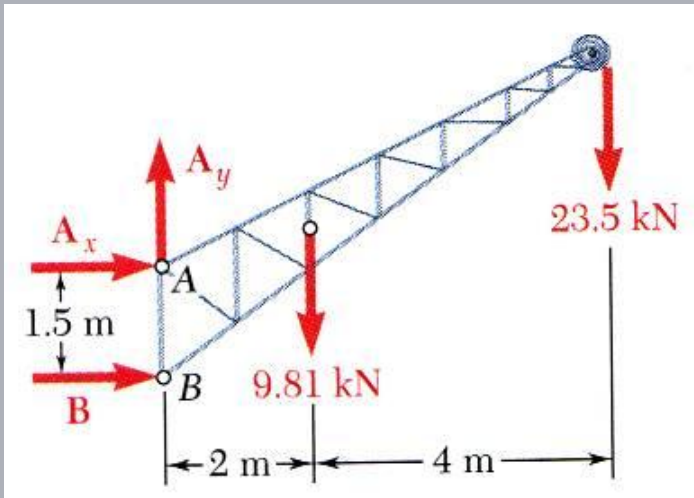

- Create the free-body diagram.

- Determine B by solving the equation for the sum of the moments of all forces about A .

$$\sum M_A = 0: \quad +B(1.5\text{m}) - 9.81\text{ kN}(2\text{m}) \\ - 23.5\text{ kN}(6\text{m}) = 0$$

$$B = +107.1\text{ kN}$$

- Determine the reactions at A by solving the equations for the sum of all horizontal forces and all vertical forces.

$$\sum F_x = 0: \quad A_x + B = 0$$

$$A_x = -107.1\text{ kN}$$

$$\sum F_y = 0: \quad A_y - 9.81\text{ kN} - 23.5\text{ kN} = 0$$

$$A_y = +33.3\text{ kN}$$

- Check the values obtained.

Sample Problem 4.3

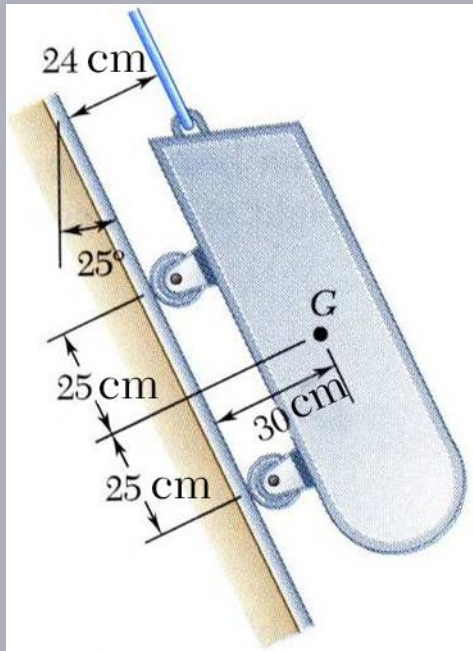

A loading car is at rest on an inclined track. The gross weight of the car and its load is 5500 N, and it is applied at G . The cart is held in position by the cable.

Determine the tension in the cable and the reaction at each pair of wheels.

SOLUTION:

- Create a free-body diagram for the car with the coordinate system aligned with the track.
- Determine the reactions at the wheels by solving equations for the sum of moments about points above each axle.
- Determine the cable tension by solving the equation for the sum of force components parallel to the track.
- Check the values obtained by verifying that the sum of force components perpendicular to the track are zero.

Sample Problem 4.3

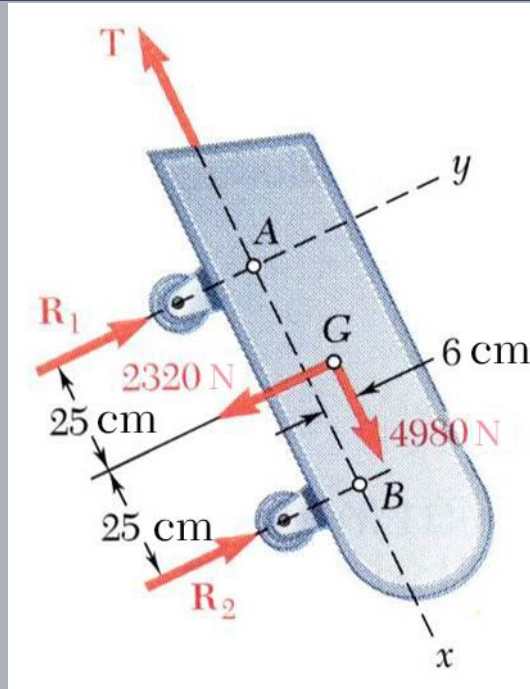

- Determine the reactions at the wheels.

$$\Sigma M_A = 0: \quad -(2320 \text{ N})25\text{cm} - (4980 \text{ N})6\text{cm} + R_2(50\text{cm}) = 0$$

$$R_2 = 1758 \text{ N}$$

$$\Sigma M_B = 0: \quad + (2320 \text{ N})25\text{cm} - (4980 \text{ N})6\text{cm} - R_1(50\text{cm}) = 0$$

$$R_1 = 562 \text{ N}$$

- Create a free-body diagram

$$\begin{aligned} W_x &= +(5500 \text{ N})\cos 25^\circ \\ &= +4980 \text{ N} \end{aligned}$$

$$\begin{aligned} W_y &= -(5500 \text{ N})\sin 25^\circ \\ &= -2320 \text{ N} \end{aligned}$$

- Determine the cable tension.

$$\Sigma F_x = 0: \quad +4980 \text{ N} - T = 0$$

$$T = +4980 \text{ N}$$

Sample Problem 4.4

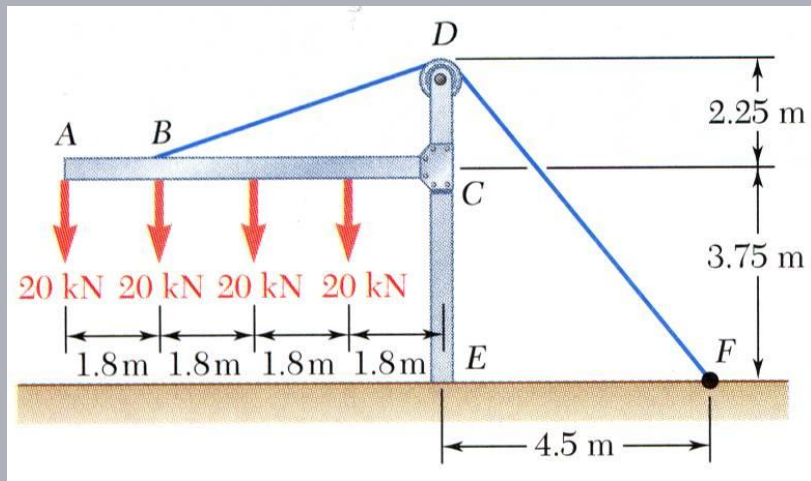

SOLUTION:

- Create a free-body diagram for the frame and cable.
- Solve 3 equilibrium equations for the reaction force components and couple at E .

The frame supports part of the roof of a small building. The tension in the cable is 150 kN.

Determine the reaction at the fixed end E .

Sample Problem 4.4

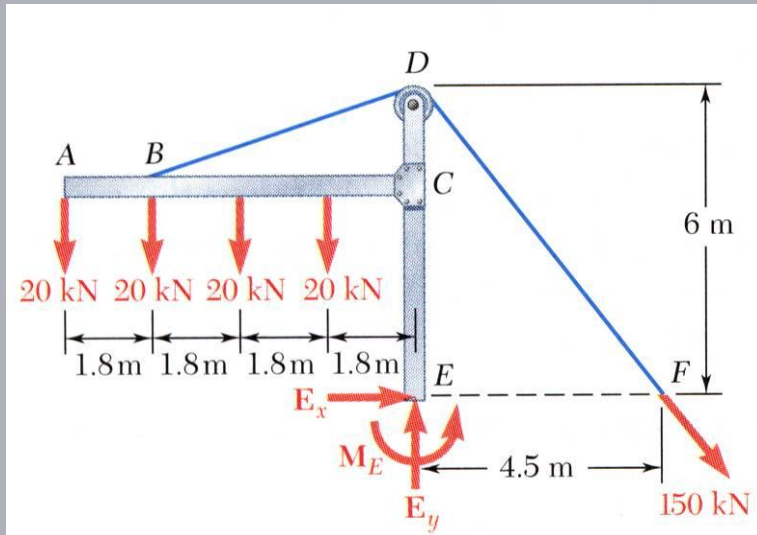

- Solve 3 equilibrium equations for the reaction force components and couple.

$$\sum F_x = 0: E_x + \frac{4.5}{7.5}(150 \text{ kN}) = 0$$

$$E_x = -90.0 \text{ kN}$$

$$\sum F_y = 0: E_y - 4(20 \text{ kN}) - \frac{6}{7.5}(150 \text{ kN}) = 0$$

$$E_y = +200 \text{ kN}$$

- Create a free-body diagram for the frame and cable.

$$\sum M_E = 0: +20 \text{ kN}(7.2 \text{ m}) + 20 \text{ kN}(5.4 \text{ m}) + 20 \text{ kN}(3.6 \text{ m}) + 20 \text{ kN}(1.8 \text{ m})$$

$$- \frac{6}{7.5}(150 \text{ kN})4.5 \text{ m} + M_E = 0$$

$$M_E = 180.0 \text{ kN} \cdot \text{m}$$

Equilibrium of a Two-Force Body

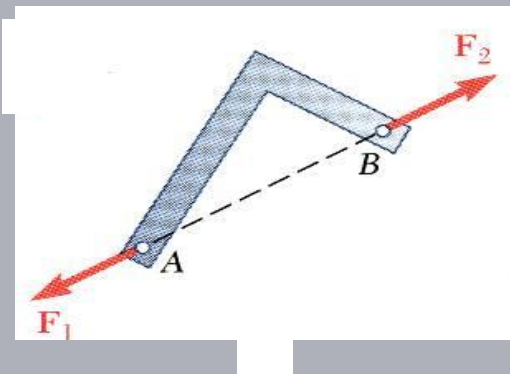
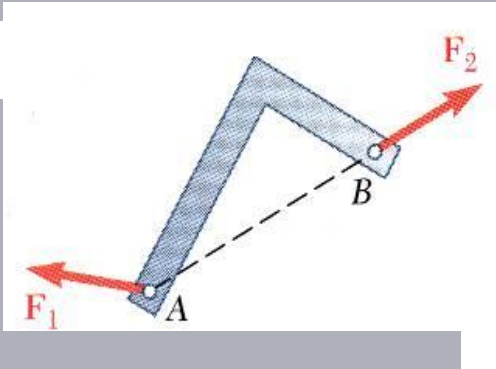
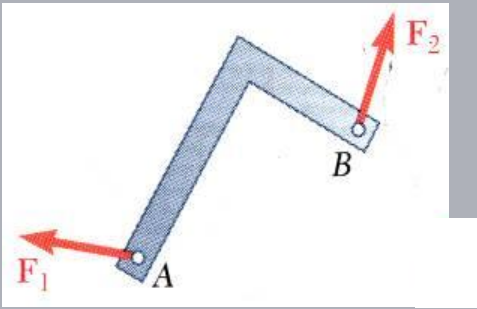

- Consider a plate subjected to two forces F_1 and F_2
- For static equilibrium, the sum of moments about A must be zero. The moment of F_2 must be zero. It follows that the line of action of F_2 must pass through A.
- Similarly, the line of action of F_1 must pass through B for the sum of moments about B to be zero.
- Requiring that the sum of forces in any direction be zero leads to the conclusion that F_1 and F_2 must have equal magnitude but opposite sense.

Sample Problem 4.6

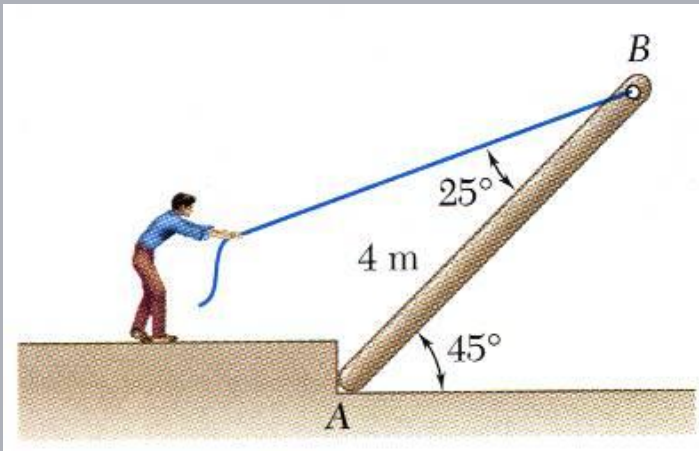

A man raises a 10 kg joist, of length 4 m, by pulling on a rope.

Find the tension in the rope and the reaction at A.

SOLUTION:

- Create a free-body diagram of the joist. Note that the joist is a 3 force body acted upon by the rope, its weight, and the reaction at A.
- The three forces must be concurrent for static equilibrium. Therefore, the reaction \mathbf{R} must pass through the intersection of the lines of action of the weight and rope forces. Determine the direction of the reaction force \mathbf{R} .
- Utilize a force triangle to determine the magnitude of the reaction force \mathbf{R} .

Sample Problem 4.6

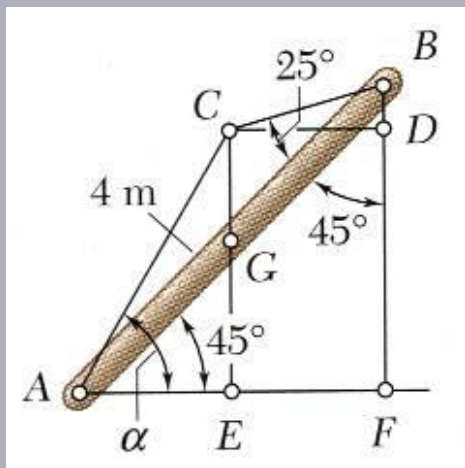
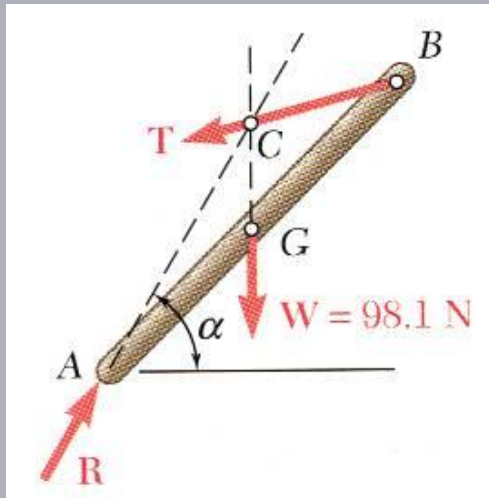

- Create a free-body diagram of the joist.
- Determine the direction of the reaction force R .

$$AF = AB \cos 45 = (4 \text{ m}) \cos 45 = 2.828 \text{ m}$$

$$CD = AE = \frac{1}{2} AF = 1.414 \text{ m}$$

$$BD = CD \cot(45 + 20) = (1.414 \text{ m}) \tan 20 = 0.515 \text{ m}$$

$$CE = BF - BD = (2.828 - 0.515) \text{ m} = 2.313 \text{ m}$$

$$\tan \alpha = \frac{CE}{AE} = \frac{2.313}{1.414} = 1.636$$

$$\alpha = 58.6^\circ$$

Sample Problem 4.6

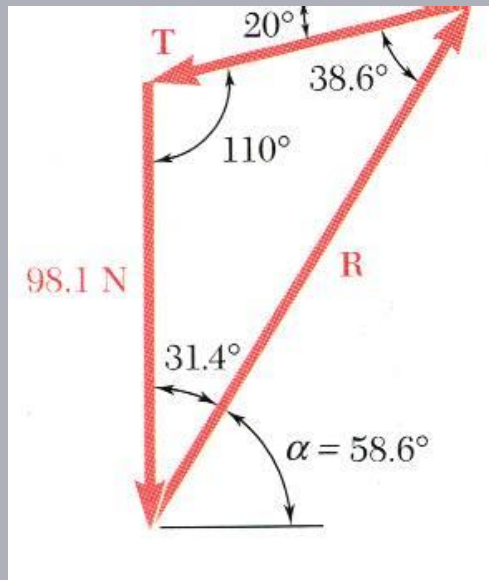

- Determine the magnitude of the reaction force R .

$$\frac{T}{\sin 31.4^\circ} = \frac{R}{\sin 110^\circ} = \frac{98.1 \text{ N}}{\sin 38.6^\circ}$$

$$T = 81.9 \text{ N}$$

$$R = 147.8 \text{ N}$$

Equilibrium of a Rigid Body in Three Dimensions

- Six scalar equations are required to express the conditions for the equilibrium of a rigid body in the general three dimensional case.

$$\begin{aligned}\sum F_x = 0 \quad \sum F_y = 0 \quad \sum F_z = 0 \\ \sum M_x = 0 \quad \sum M_y = 0 \quad \sum M_z = 0\end{aligned}$$

- These equations can be solved for no more than 6 unknowns which generally represent reactions at supports or connections.
- The scalar equations are conveniently obtained by applying the vector forms of the conditions for equilibrium,

$$\sum \vec{F} = 0 \quad \sum \vec{M}_O = \sum (\vec{r} \times \vec{F}) = 0$$

Reactions at Supports and Connections for a Three-Dimensional Structure

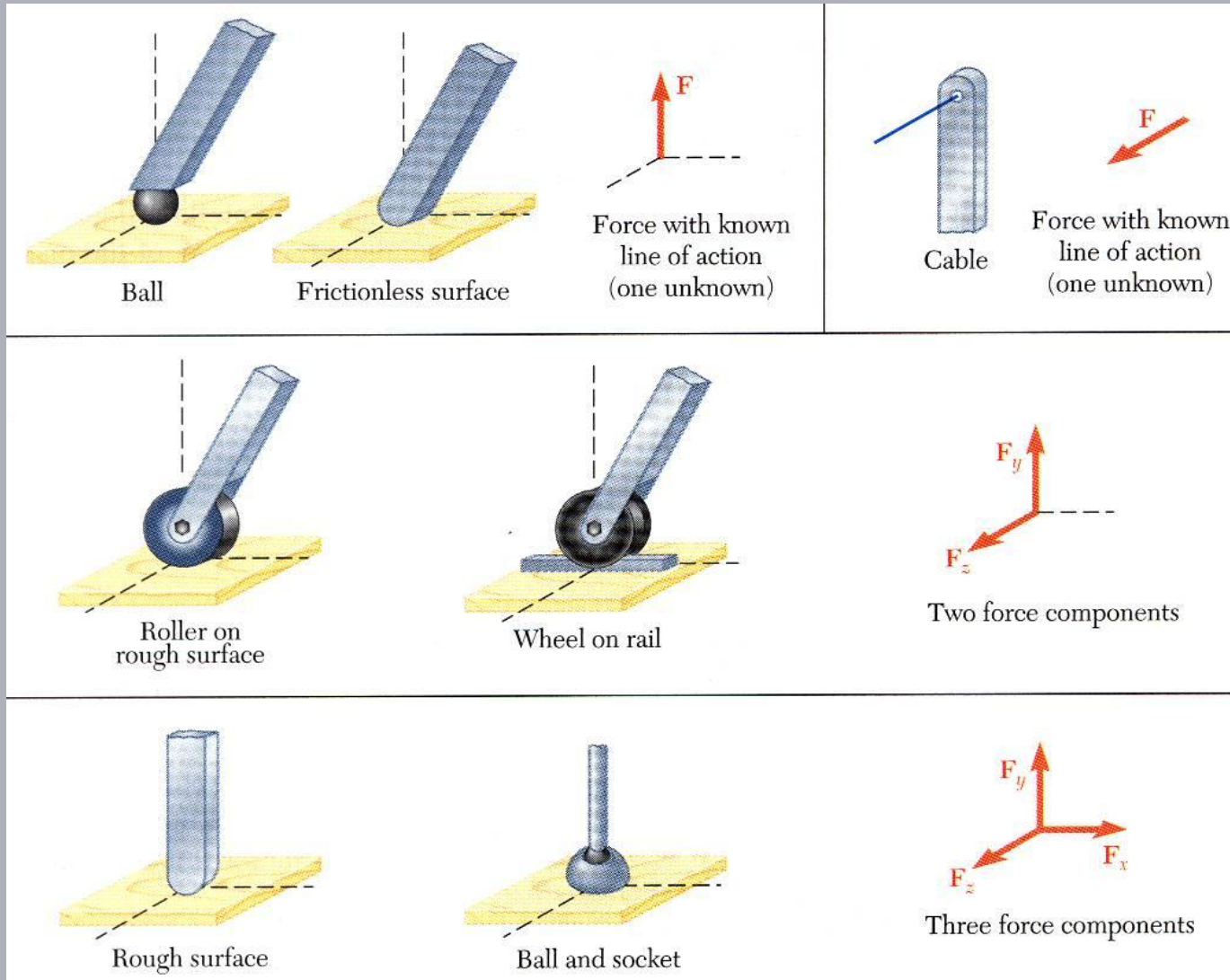

Reactions at Supports and Connections for a Three-Dimensional Structure

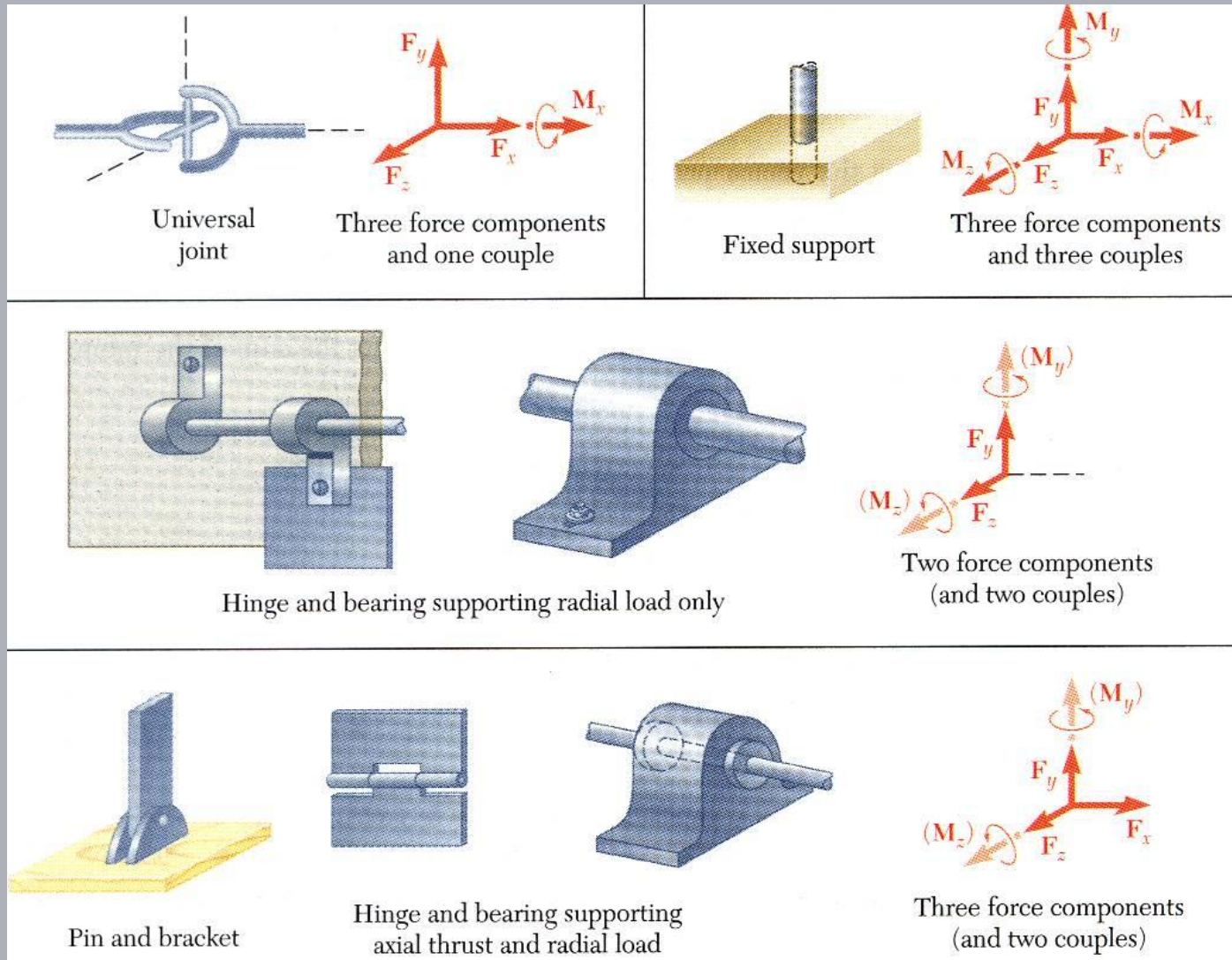

Sample Problem 4.8

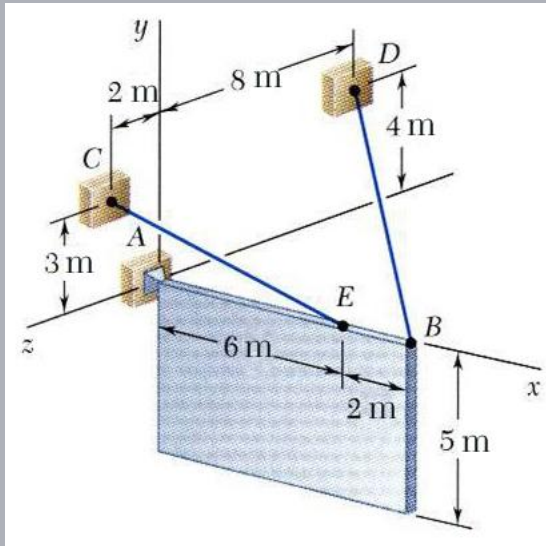

SOLUTION:

- Create a free-body diagram for the sign.
- Apply the conditions for static equilibrium to develop equations for the unknown reactions.

A sign of uniform density weighs 270 N and is supported by a ball-and-socket joint at A and by two cables.

Determine the tension in each cable and the reaction at A.

Sample Problem 4.8

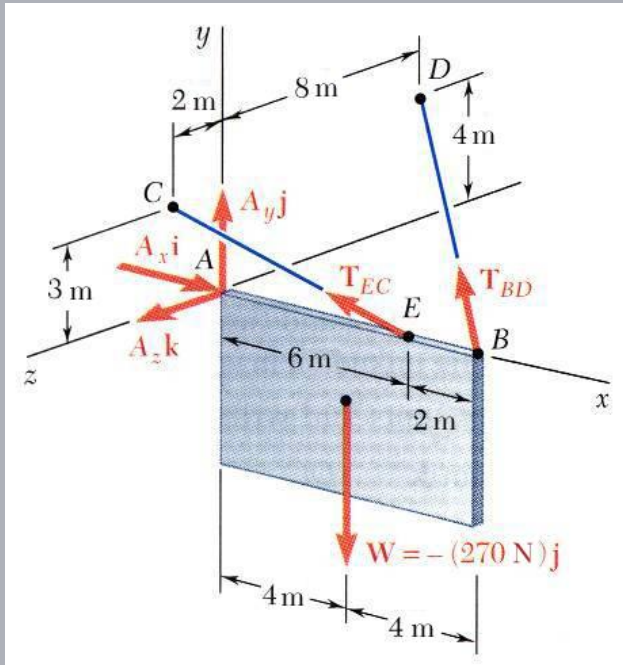

- Create a free-body diagram for the sign.

Since there are only 5 unknowns, the sign is partially constrain. It is free to rotate about the x axis. It is, however, in equilibrium for the given loading.

$$\begin{aligned}\vec{T}_{BD} &= T_{BD} \frac{\vec{r}_D - \vec{r}_B}{|\vec{r}_D - \vec{r}_B|} \\ &= T_{BD} \frac{-8\vec{i} + 4\vec{j} - 8\vec{k}}{12} \\ &= T_{BD} \left(-\frac{2}{3}\vec{i} + \frac{1}{3}\vec{j} - \frac{2}{3}\vec{k} \right)\end{aligned}$$

$$\begin{aligned}\vec{T}_{EC} &= T_{EC} \frac{\vec{r}_C - \vec{r}_E}{|\vec{r}_C - \vec{r}_E|} \\ &= T_{EC} \frac{-6\vec{i} + 3\vec{j} + 2\vec{k}}{7} \\ &= T_{EC} \left(-\frac{6}{7}\vec{i} + \frac{3}{7}\vec{j} + \frac{2}{7}\vec{k} \right)\end{aligned}$$

Sample Problem 4.8

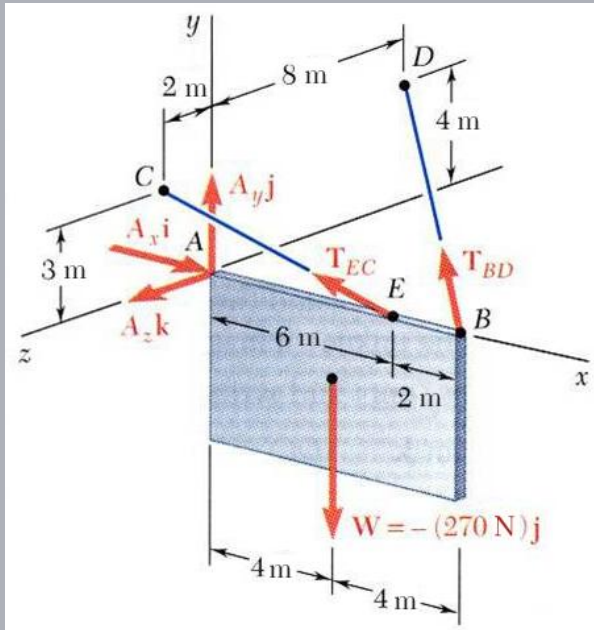

$$\Sigma \vec{F} = \vec{A} + \vec{T}_{BD} + \vec{T}_{EC} - (270 \text{ N})\vec{j} = 0$$

$$\vec{i}: A_x - \frac{2}{3}T_{BD} - \frac{6}{7}T_{EC} = 0$$

$$\vec{j}: A_y + \frac{1}{3}T_{BD} + \frac{3}{7}T_{EC} - 270 \text{ N} = 0$$

$$\vec{k}: A_z - \frac{2}{3}T_{BD} + \frac{2}{7}T_{EC} = 0$$

$$\Sigma \vec{M}_A = \vec{r}_B \times \vec{T}_{BD} + \vec{r}_E \times \vec{T}_{EC} + (4 \text{ m})\vec{i} \times (-270 \text{ N})\vec{j} = 0$$

$$\vec{j}: 5.333T_{BD} - 1.714T_{EC} = 0$$

$$\vec{k}: 2.667T_{BD} + 2.571T_{EC} - 1080 \text{ N} = 0$$

- Apply the conditions for static equilibrium to develop equations for the unknown reactions.

Solve the 5 equations for the 5 unknowns,

$$T_{BD} = 101.3 \text{ N} \quad T_{EC} = 315 \text{ N}$$

$$\vec{A} = (338 \text{ N})\vec{i} + (101.2 \text{ N})\vec{j} - (22.5 \text{ N})\vec{k}$$