

Question 1 (40 points: 15 + 10+ 15):

- (a) Convert the following binary into (i) decimal, (ii) octal et (iii) hexadecimal
10100001111.1101

(i) to decimal

$$(10100001111)_2$$

$$= 1 \times 2^{10} + 0 \times 2^9 + 1 \times 2^8 + 0 \times 2^7 + 0 \times 2^6 + 0 \times 2^5 + 0 \times 2^4 + 1 \times 2^3 + 1 \times 2^2 + 1 \times 2^1 + 1 \times 2^0$$

$$= 1024 + 0 + 256 + 0 + 0 + 0 + 0 + 8 + 4 + 2 + 1$$

$$= 1295$$

$$(0.1101)_2$$

$$= 1 \times 2^{-1} + 1 \times 2^{-2} + 0 \times 2^{-3} + 1 \times 2^{-4}$$

$$= 0.5 + 0.25 + 0 + 0.0625$$

$$= 0.8125$$

$$(10100001111.1101)_2 = \mathbf{1295.8125}$$

Binary Octal

000	0
001	1
010	2
011	3
100	4
101	5
110	6

(ii) to Octal

$$(10100001111)_2$$

$$= 010\ 100\ 001\ 111.110\ 100$$

$$= \mathbf{2417.64}$$

(ii) to Hexadecimal

$$(10100001111)_2$$

$$= 0101\ 0000\ 1111.1101$$

$$= \mathbf{50F.D}$$

Binary Hexa

0000	0
0001	1
0010	2
0011	3
0100	4
0101	5
0110	6
0111	7
1000	8
1001	9
1010	A
1011	B
1100	C
1101	D
1110	E

(b) Perform the following operation using 10's complement

$$(162)_{10} - (27)_{10}$$

$$[N]_r = r^n - (N)_r$$

$$n = 3$$

$$r = 10$$

$$N = 027$$

$$\begin{aligned} [027]_{10} &= 10^3 - (27)_{10} \\ &= 973 \end{aligned}$$

$$10\text{'s Complement of } (27)_{10} = 973$$

$$(162)_{10} - (27)_{10} = (162)_{10} + 10\text{'s Complement of } (27)_{10}$$

$$= (162)_{10} + (973)_{10}$$

$$= (135)_{10}$$

$$\begin{array}{r} 11 \\ | \\ 162 \\ + 973 \\ \hline \cancel{X}135 \end{array}$$

(c) Convert the following numbers into binary and perform the arithmetic operations in (i) and (ii) using signed binary numbers with 2's complement. Use 7 bits to represent the integer part of decimal numbers and the sign bit. Use three bits to represent the fractional part.

	(i) $(4.5)_{10} - (9)_{10}$	$4/2 = 2 \text{ rem } 0 \uparrow$	$9/2 = 4 \text{ rem } 1 \uparrow$
	(ii) $(8.5)_{10} + (9)_{10}$	$2/2 = 1 \text{ rem } 0$	$4/2 = 2 \text{ rem } 0$
$(4.5)_{10} = 0000100.100$		$1/2 = 0 \text{ rem } 1$	$2/2 = 1 \text{ rem } 0$
			$1/2 = 0 \text{ rem } 1$
$(9)_{10} = 0001001.000$		$8/2 = 4 \text{ rem } 0 \uparrow$	
$2\text{'s of } (9)_{10} = 1110111.000$		$4/2 = 2 \text{ rem } 0$	$0.5 * 2 = 1.0 \downarrow$
		$2/2 = 1 \text{ rem } 0$	
$(8.5)_{10} = 0001000.100$		$1/2 = 0 \text{ rem } 1$	

(i) $(4.5)_{10} - (9)_{10}$

$$\begin{aligned}
 &= 0000100.100 - 0001001.000 \\
 &= 0000100.100 + 2\text{'s of } (0001001.000) \\
 &= 0000100.100 + 1110111.000 \\
 &= \mathbf{1111011.100} \\
 &= - (0000100.100) \\
 &= - (4.5)_{10}
 \end{aligned}$$

$$\begin{array}{r}
 1 \\
 0000100.100 \\
 + 1110111.000 \\
 \hline
 1111011.100
 \end{array}$$

(ii) $(8.5)_{10} + (9)_{10}$

$$\begin{aligned}
 &= 0001000.100 + 0001001.000 \\
 &= \mathbf{0010001.100} \\
 &= (17.5)_{10}
 \end{aligned}$$

$$\begin{array}{r}
 1 \\
 0001000.100 \\
 + 0001001.000 \\
 \hline
 0010001.100
 \end{array}$$

Question 2: (10 + 30 + 5 + 15 = 60 points)

Design a 4-bit combinational circuit 2's complementer. The circuit generates at the output the 2's complement of the input binary numbers.

Answer the following questions:

(i) Complete the following truth table. A,B,C,D indicate the input binary number to be complemented using 2's complement and W,X,Y, Z represent the output 2's complement of the input binary number. The variable D is the least significant bit and A is the most significant bit of the binary number.

A	B	C	D	w	x	y	z
0	0	0	0	0	0	0	0
0	0	0	1	1	1	1	1
0	0	1	0	1	1	1	0
0	0	1	1	1	1	0	1
0	1	0	0	1	1	0	0
0	1	0	1	1	0	1	1
0	1	1	0	1	0	1	0
0	1	1	1	1	0	0	1
1	0	0	0	1	0	0	0
1	0	0	1	0	1	1	1
1	0	1	0	0	1	1	0
1	0	1	1	0	1	0	1
1	1	0	0	0	1	0	0
1	1	0	1	0	0	1	1
1	1	1	0	0	0	1	0
1	1	1	1	0	0	0	1

(ii) Simplify the Boolean function **W** in its **Sum of Products form** using K-Map

	00	01	11	10
00	0	1	1	1
01	1	1	1	1
11	0	0	0	0
10	1	0	0	0

$$W = A'B + A'D + A'C + AB'C'D'$$

(iii) Show that the Boolean function W can be constructed using exclusive-OR gates

$$\begin{aligned}W &= A'B + A'D + A'C + AB'C'D' \\ &= A'(B + D + C) + AB'C'D'\end{aligned}$$

$$\begin{aligned}B'C'D' &= (B + C + D)' \\ X &= (B + C + D)\end{aligned}$$

$$\begin{aligned}W &= A'(B + D + C) + A(B + C + D)' \\ W &= A'X + AX'\end{aligned}$$

$$\begin{aligned}W &= A \oplus X \\ W &= A \oplus (B + D + C)\end{aligned}$$

(iv) Implement the Boolean function Z in its **Product of Sums form** with a decoder constructed with NAND gates (see figure below) and external gate (s) connected to the decoder outputs.

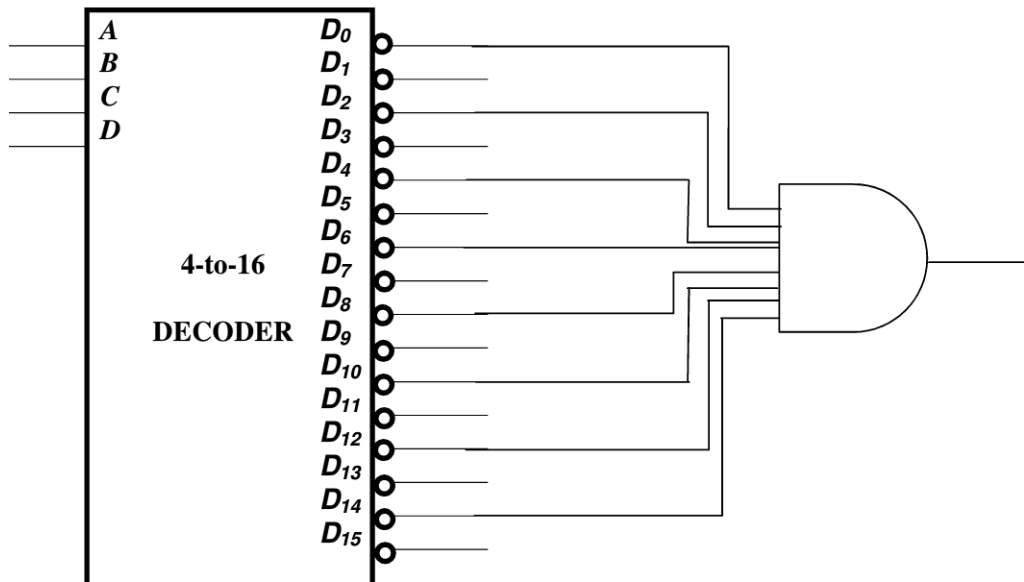

Sum of Products

$$Z = \sum m(1,3,5,7,9,11,13,15)$$

$$Z = \prod M(0,2,4,6,8,10,12,14)$$

$$Z_{\text{SOP}} = A'B'C'D + A'B'CD + A'BC'D + A'BCD + AB'C'D + AB'CD + ABC'D + ABCD$$

$$Z' = A'B'C'D' + A'B'CD' + A'BC'D' + A'BCD' + AB'C'D' + AB'CD' + ABC'D' + ABCD'$$

$$Z'' = Z_{\text{POS}}$$

$$(A+B+C+D)(A+B+C'+D)(A+B'+C+D)(A+B'+C'+D)(A'+B+C+D)(A'+B+C'+D)(A'+B'+C+D)(A'+B'+C'+D)$$