

## Sample Final Exam

### ADM 3301: PRODUCTION AND OPERATIONS MANAGEMENT

Professor: Rim Jaber

Time: Three (3) hours

**Last Name:** \_\_\_\_\_ **First Name:** \_\_\_\_\_

**Student Identification Number:** \_\_\_\_\_

**Instructions to students:**

- 1- Write down the exam copy number (that exists at the top right corner of this page) on the identification white card next to your name.
- 2- Verify that your exam has 13 pages (including this title page). Statistical tables are provided on page 13.
- 3- Answer all questions on your examination copy. **Use the opposite (blank) side, if necessary.** Answers or calculations written on the sheet of notes will not be evaluated.
- 4- Justify all answers with proper arguments and/or calculations. Be precise, clear and concise: ambiguous or vague statements will be considered false. Please write legibly: What I cannot read will not be marked.
- 5- This is a closed-book exam: however, one double sided sheet (8.5" x 11") of notes and a calculator are permitted for arithmetic use only. **The sheet of notes must be handed over with the exam copy at the end of the exam period, or else your copy will not be marked.**
- 6- The value of each question is indicated on the left margin for a total of 80 marks.
- 7- **NO COMMUNICATION DEVICES MAY BE WITHIN SIGHT DURING THE EXAM PERIOD.**

**GOOD LUCK AND HAVE A GREAT HOLIDAY!**

Problem	Description	Page	Marks	Total
1	Material Requirements Planning	p. 2	23	
2	Inventory Management: Deterministic Demand	p.5	7	
3	Inventory Management: Probabilistic Demand	p. 6	17	
4	Just-In-Time Philosophy	p. 8	9	
5	Quality Control: Control Charts	p. 9	10	
6	Quality Control: Process Capability	p. 11	4	
7	Total Quality Management and miscellaneous topics	p. 12	10	
<b>Total</b>			<b>80</b>	

**Statement of Academic Integrity**

The School of Management does not condone academic fraud, an act by a student that may result in a false academic evaluation of that student or of another student. Without limiting the generality of this definition, academic fraud occurs when a student commits any of the following offences: plagiarism or cheating of any kind, use of books, notes, mathematical tables, dictionaries or other study aid unless an explicit written note to the contrary appears on the exam, to have in his/her possession cameras, radios (radios with head sets), tape recorders, pagers, cell phones, or any other communication device which has not been previously authorized in writing.

**Statement to be signed by the student:**

I have read the text on academic integrity and I pledge not to have committed or attempted to commit academic fraud in this examination.

Signed: \_\_\_\_\_

Note: an examination copy or booklet without that signed statement will not be graded and will receive a final exam grade of zero.

[23] **Problem 1**                      **Material Requirements Planning**

The product structure tree of product A is given below. The lead times and available inventories of each item are found in the following table.

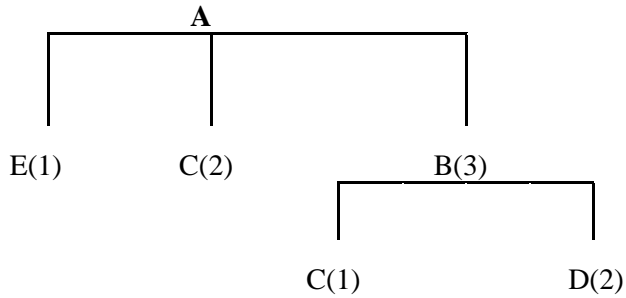
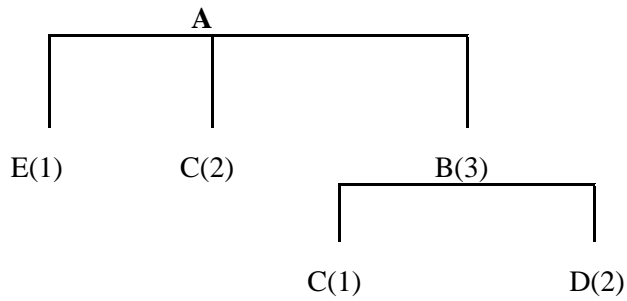

**Table 1**

Item	Lead Time	Available Inventory
A	2 weeks	200
B	2 weeks	1000
C	1 week	1500
D	3 weeks	8500
E	4 weeks	900

[3] (a) Given the available inventories, how many additional units of E must be ordered if a total of 2,000 units of A are required? Show your work. (*Hint:* You do not need to develop an MRP plan; also, do not specify when the units of E must be ordered: we only want the total number of E to order).

[6] (b) Given the available inventories, how many additional units of C must be ordered if a total of 2,000 units of A are required? Show your work. (*Hint:* You do not need to develop an MRP plan; also, do not specify when the units of C must be ordered: we only want the total number of C to order).



**Table 1**

<b>Item</b>	<b>Lead Time</b>	<b>Available Inventory</b>
A	2 weeks	200
B	2 weeks	1000
C	1 week	1500
D	3 weeks	8500
E	4 weeks	900

- [6] (c) **Treat the following questions independently;** show your work for each answer. Given the available inventories and assembly lead times, what is the maximum amount of product A that could be supplied to customers:
- [2] i) now (i.e. at the beginning of week 1)? Briefly Justify.
- [4] ii) within the next two weeks (i.e. on the beginning of week 3, assuming we are at the beginning of week 1)? Show your calculations.

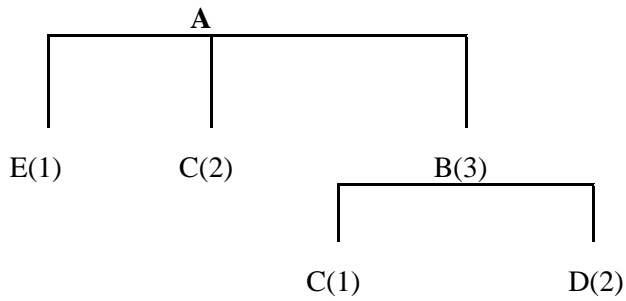

**Table 1**

Item	Lead Time	Available Inventory
A	2 weeks	200
B	2 weeks	1000
C	1 week	1500
D	3 weeks	8500
E	4 weeks	900

[6] (d) Given the available inventories and assembly lead times, complete the following table.

Week:	1	2	3	4	5	6	7	8
Item: A								
Gross Requirements								1,200
Available								
Net Requirements								
Plan. Order Receipts								
Plan. Order Releases								
Item: B								
Gross Requirements								
Available								
Net Requirements								
Plan. Order Receipts								
Plan. Order Releases								
Item: C								
Gross Requirements								
Available								
Net Requirements								
Plan. Order Receipts								
Plan. Order Releases								
Item: D								
Gross Requirements								
Available								
Net Requirements								
Plan. Order Receipts								
Plan. Order Releases								
Item: E								
Gross Requirements								
Available								
Net Requirements								
Plan. Order Receipts								
Plan. Order Releases								

[2] (e) Given the available inventories and assembly lead times, how many weeks would be needed to meet a gross requirement of 1,200 units of A? At the earliest, at the beginning of what week could an order of 1,200 units of A be delivered? Justify and be precise.

[7] **Problem 2**                      **Inventory Management: Deterministic Demand**

**QUESTION (a) AND (b) ARE INDEPENDENTS**

- [3] (a) The Dine Corporation is both a producer and a user of brass couplings. The firm operates 220 days per year and uses the couplings at a steady rate of 50 per day. Couplings can be produced at a rate of 200 per day. Assume storage costs are \$1 per coupling per year, and machine setup costs (or ordering costs) are \$35.

What is the optimal production order quantity of brass couplings?

- [4] (b) Burger Prince orders paper cups from a supplier, and uses the basic Economic Order Quantity model to determine the order quantity. The ordering cost is constant and fixed irrespective of the order quantity, while the holding cost is determined as a certain percentage of the purchase cost of paper cups. Burger Prince was told that the cost of paper cups would increase by 10%.

[2] i) Should the order quantity change and if so, Should Burger Prince order more or less than before? Briefly Justify.

[2] ii) By what percentage the order quantity will increase or decrease following the increase of 10% in the cost of paper cups? show your calculations.

[17] **Problem 3**                      **Inventory Management: Probabilistic Demand**

Weekly demand of a product is stationary and has been forecasted using exponential smoothing. The expected demand is 196 units per week and the standard deviation of weekly demand is 25. The item is purchased from a vendor at a cost of \$10 per unit: the ordering cost is \$50 with a lead time of one (1) week; The holding cost is \$6 per unit per year. Assume there are exactly 52 weeks per year. **The following questions are all based on these data, but are independent.**

- [4] (a) Assume the manager decided to adopt a fixed-order-quantity model, but decided not to carry any safety stock (e.g. the size of the safety stock is 0). Calculate the probability of stocking out during the lead time, and the expected demand units lost during the lead time. Show your work and give sufficient details.

[2] **Probability of stocking out during lead time:**

[2] **Expected demand units lost during the lead time:**

**NOT DISCUSSED IN CLASS, thus not included on the final exam.**

- [4] (b) Assume the manager decided to adopt a fixed-order-quantity model, and wishes to maintain a 90% service level. Calculate the optimal order quantity and the reorder point. Show your work and give sufficient details. (**Reminder: this question is independent of question (a)** ).

[2] **Optimal Order Quantity:**

[2] **Reorder Point:**

- [5] (c) Assume now the manager decided to adopt a fixed-time-period model with  $T = 4$  weeks as review period (i.e. time between orders). Assume the beginning inventory is 300 units. What should the order quantity be so that 98% of the demand will be satisfied? Show your work and give sufficient details.
- [4] (d) The production manager wishes to set up a fixed-time-period inventory system so that the probability of stockout is at most 2.5%. However, given storage space constraints, the size of the safety stock must be at most equal to the expected demand over one week which is 196 units. What is the maximum time between orders (e.g.  $T$  is the time between two orders) that would meet these criteria? Show all your work.

**[9] Problem 4 Just-in-Time Philosophy**

To illustrate the process of "continuous improvement" and "elimination of waste", a "Just-in-Time Production Game" was played in class: an inefficient production system was simulated, the inefficiencies were analyzed and a discussion followed, during which possible changes were proposed that would facilitate the transition of the production system to a "Just-in-Time" system.

State three of the seven JIT success factors which were implemented and briefly explain how they were used to eliminate inefficiencies. In each case, refer specifically to something that was done in the game.

**JIT success factor number 1:** \_\_\_\_\_

**Change to the system and resulting elimination of inefficiencies (please refer to the game):**

**JIT success factor number 2:** \_\_\_\_\_

**Change to the system and resulting elimination of inefficiencies (please refer to the game):**

**JIT success factor number 3:** \_\_\_\_\_

**Change to the system and resulting elimination of inefficiencies (please refer to the game):**

**[10] Problem 5 Quality Control: Control Charts**

Forty-eight (48) samples of 100 units each were taken on the production of an assembly line manufacturing microchips. The system operates around the clock, and there are two 12-hour shifts: the day shift begins work at 7:00 and the night shift begins work at 19:00. One sample was taken at the end of each production hour for a period of two consecutive days. The sample results are summarized in the Table below (samples taken between 8:00 and 19:00 inclusive were taken on the production of the day shift):

Time	Number of Defective Chips		Time	Number of Defective Chips	
Day shift	Day 1	Day 2	Night Shift	Day 1	Day 2
8:00	2	1	20:00	2	2
9:00	2	2	21:00	1	2
10:00	0	1	22:00	3	3
11:00	3	4	23:00	3	4
12:00	3	2	0:00	3	3
13:00	5	4	1:00	4	3
14:00	4	5	2:00	5	5
15:00	5	5	3:00	4	5
16:00	5	6	4:00	5	5
17:00	7	6	5:00	6	7
18:00	6	5	6:00	7	8
19:00	7	7	7:00	9	8
Total	49	48	Total	52	55

[4] (a) Using these data, calculate 99% upper and lower control limits.

Upper Control Limits (UCL):

Lower Control Limits (LCL):

- [6] (b) Below you will find a plot of the percentage of defectives for each of the forty-eight (48) samples taken during the two days of the study. On the graph, show clearly the average proportion of defective chips and the 99% control limits to complete the control chart. From this chart, what are your conclusions and recommendations?

[2] **Control limits and average proportion on graph**

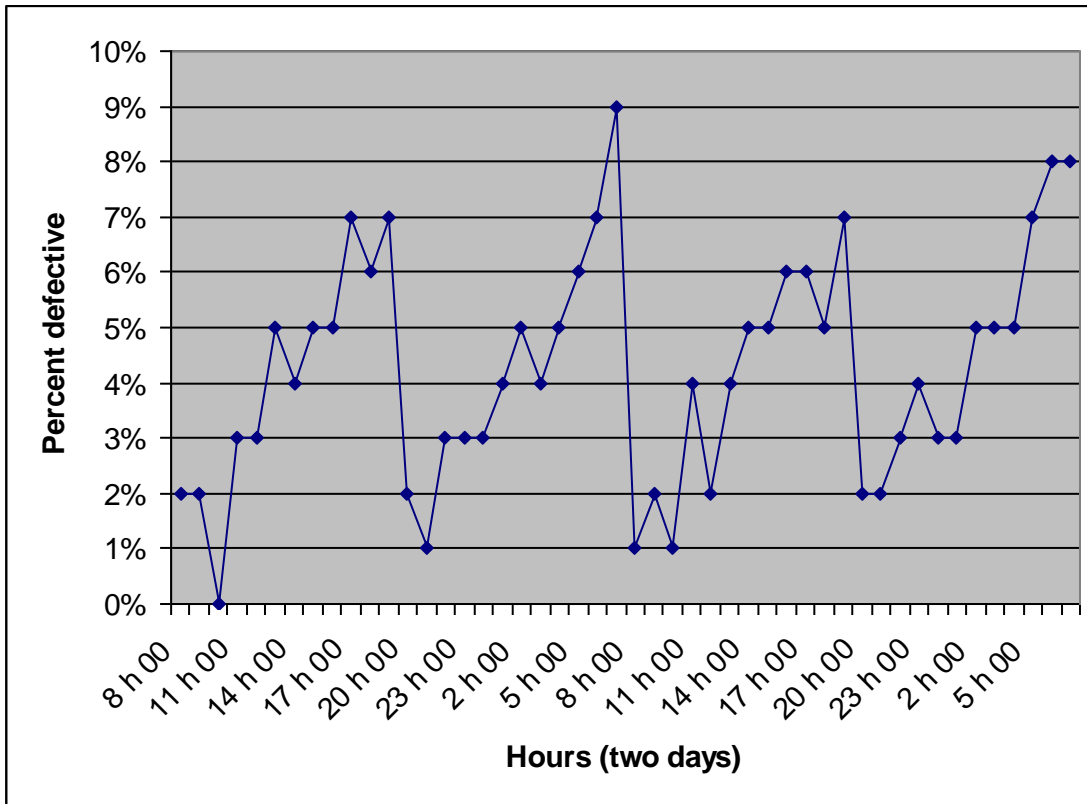

[2] **Conclusions (interpretation of the the control chart graph):**

[2] **Recommendations (action to take based on your conclusions):**

[4] **Problem 6**                      **Quality Control: Process Capability**

In an assembly line, resistances for micro-chips are manufactured. Random samples taken regularly on the production of these resistances have shown that the average resistance is 1,000 ohms, and that the standard deviation is 3 ohms. According to specifications, only resistances between 994 and 1,006 ohms are acceptable.

[2] (a) Calculate the Process Capability. What can you conclude?

[2] (b) What proportion of all resistances produced meet the specifications? Show all your calculations.

[8] **Problem 7:** Circle the proper answer to each question or fill in the blank

Statistical Tables

Areas of the Standard Normal Distribution

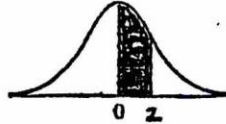

An entry in the table is the proportion under the entire curve which is between  $z = 0$  and a positive value of  $z$ . Areas for negative values of  $z$  are obtained by symmetry.

$z$	.00	.01	.02	.03	.04	.05	.06	.07	.08	.09
0.0	.0000	.0040	.0080	.0120	.0160	.0199	.0239	.0279	.0319	.0359
0.1	.0398	.0438	.0478	.0517	.0557	.0596	.0636	.0675	.0714	.0753
0.2	.0793	.0832	.0871	.0910	.0948	.0987	.1026	.1064	.1103	.1141
0.3	.1179	.1217	.1255	.1293	.1331	.1368	.1406	.1443	.1480	.1517
0.4	.1554	.1591	.1628	.1664	.1700	.1736	.1772	.1808	.1844	.1879
0.5	.1915	.1950	.1985	.2019	.2054	.2088	.2123	.2157	.2190	.2224
0.6	.2257	.2291	.2324	.2357	.2389	.2422	.2454	.2486	.2517	.2549
0.7	.2580	.2611	.2642	.2673	.2703	.2734	.2764	.2794	.2823	.2852
0.8	.2881	.2910	.2939	.2967	.2995	.3023	.3051	.3078	.3106	.3133
0.9	.3159	.3186	.3212	.3238	.3264	.3289	.3315	.3340	.3365	.3389
1.0	.3413	.3438	.3461	.3485	.3508	.3531	.3554	.3577	.3599	.3621
1.1	.3643	.3665	.3686	.3708	.3729	.3749	.3770	.3790	.3810	.3830
1.2	.3849	.3869	.3888	.3907	.3925	.3944	.3962	.3980	.3997	.4015
1.3	.4032	.4049	.4066	.4082	.4099	.4115	.4131	.4147	.4162	.4177
1.4	.4192	.4207	.4222	.4236	.4251	.4265	.4279	.4292	.4306	.4319
1.5	.4332	.4345	.4357	.4370	.4382	.4394	.4406	.4418	.4429	.4441
1.6	.4452	.4463	.4474	.4484	.4495	.4505	.4515	.4525	.4535	.4545
1.7	.4554	.4564	.4573	.4582	.4591	.4599	.4608	.4616	.4625	.4633
1.8	.4641	.4649	.4656	.4664	.4671	.4678	.4686	.4693	.4699	.4706
1.9	.4713	.4719	.4726	.4732	.4738	.4744	.4750	.4756	.4761	.4767
2.0	.4772	.4778	.4783	.4788	.4793	.4798	.4803	.4808	.4812	.4817
2.1	.4821	.4826	.4830	.4834	.4838	.4842	.4846	.4850	.4854	.4857
2.2	.4861	.4864	.4868	.4871	.4875	.4878	.4881	.4884	.4887	.4890
2.3	.4893	.4896	.4898	.4901	.4904	.4906	.4909	.4911	.4913	.4916
2.4	.4918	.4920	.4922	.4925	.4927	.4929	.4931	.4932	.4934	.4936
2.5	.4938	.4940	.4941	.4943	.4945	.4946	.4948	.4949	.4951	.4952
2.6	.4953	.4955	.4956	.4957	.4959	.4960	.4961	.4962	.4963	.4964
2.7	.4965	.4966	.4967	.4968	.4969	.4970	.4971	.4972	.4973	.4974
2.8	.4974	.4975	.4976	.4977	.4977	.4978	.4979	.4979	.4980	.4981
2.9	.4981	.4982	.4982	.4983	.4984	.4984	.4985	.4985	.4986	.4986
3.0	.4987	.4987	.4987	.4988	.4988	.4989	.4989	.4989	.4990	.4990