

Step 1:

The program should prompt the user to choose between 3 options: calculate resistor value, help, and exit. If user chooses calculate resistor value, user should be prompted to enter 4 color bands. The resistor value should then be calculated and displayed. If user chooses help he should be given instructions on how to use the program. Finally, if user chooses exit it the program should terminate. If at any time the user enters an incorrect value he should be prompted to reenter value. The program should continue until user chooses exit option.

Step 2:

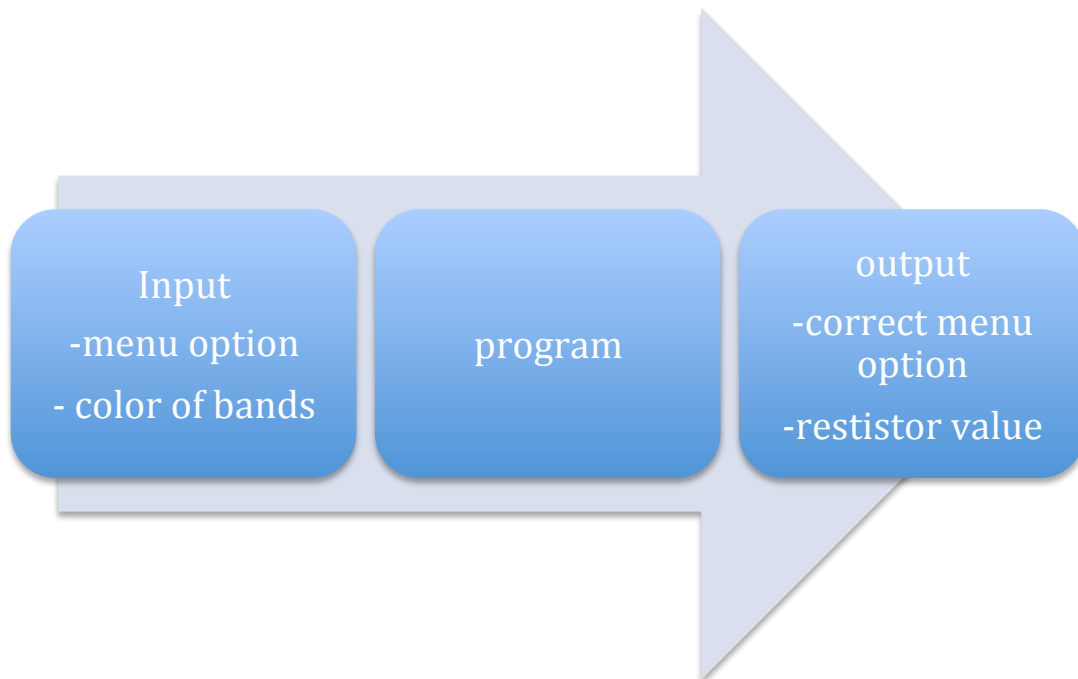

Step 3: True: ✓
False: ✗

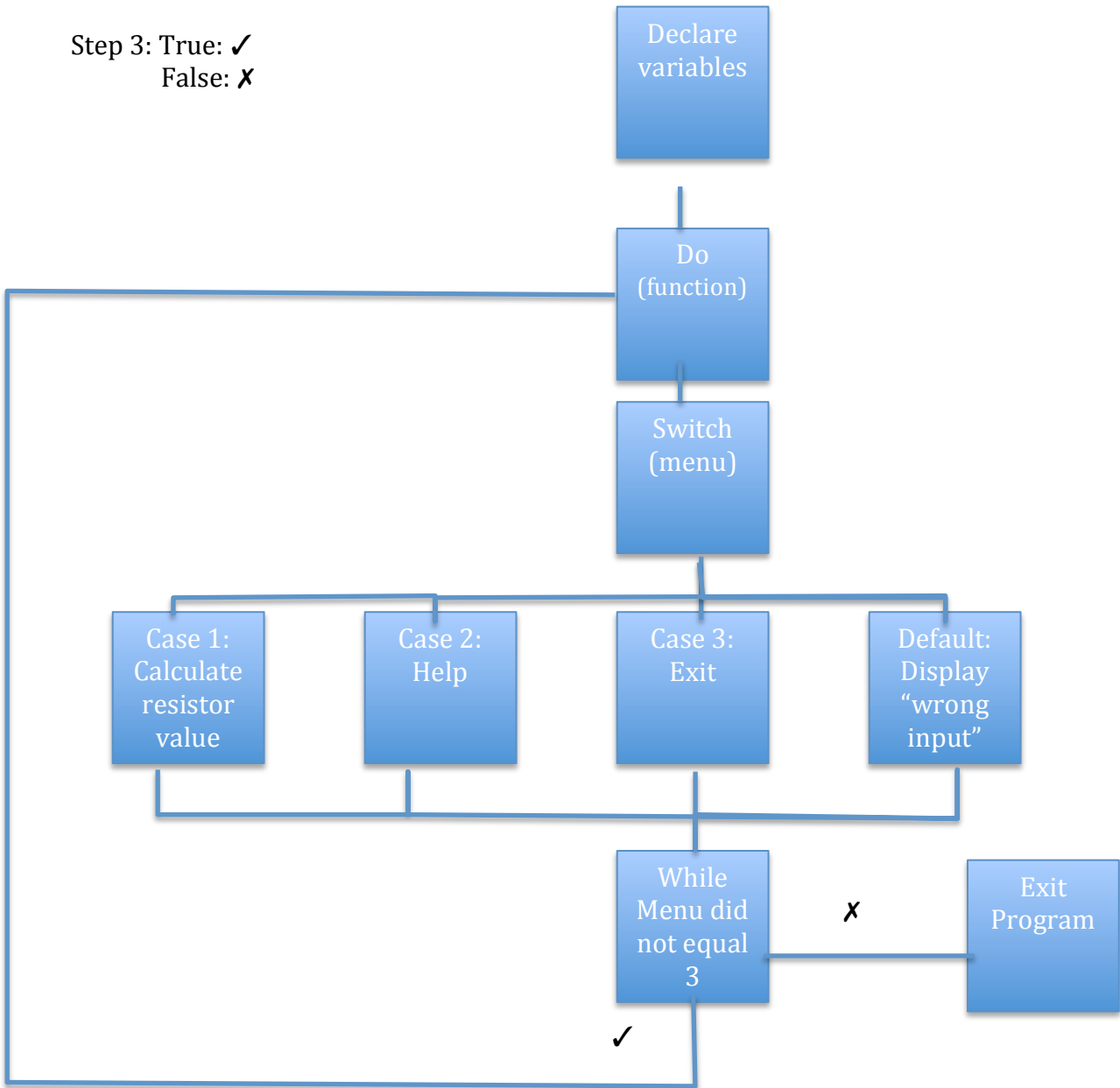

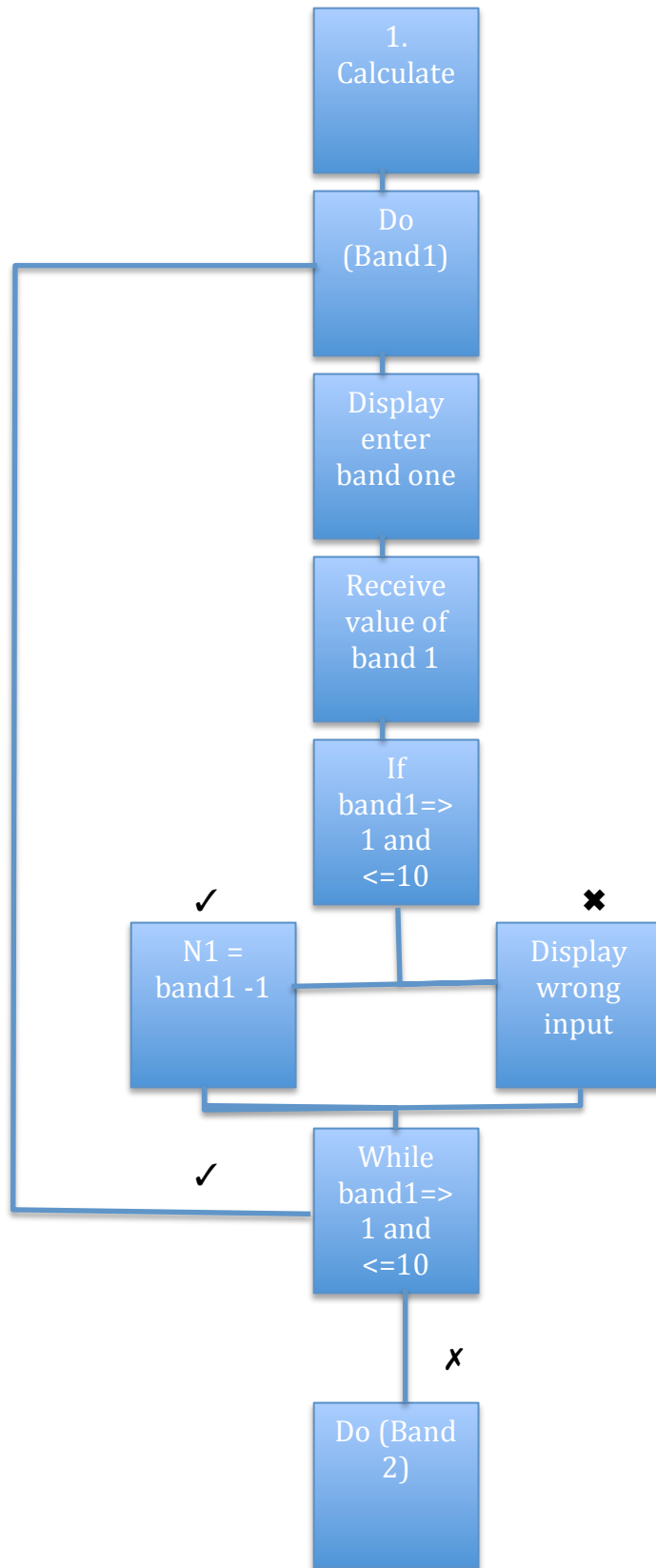

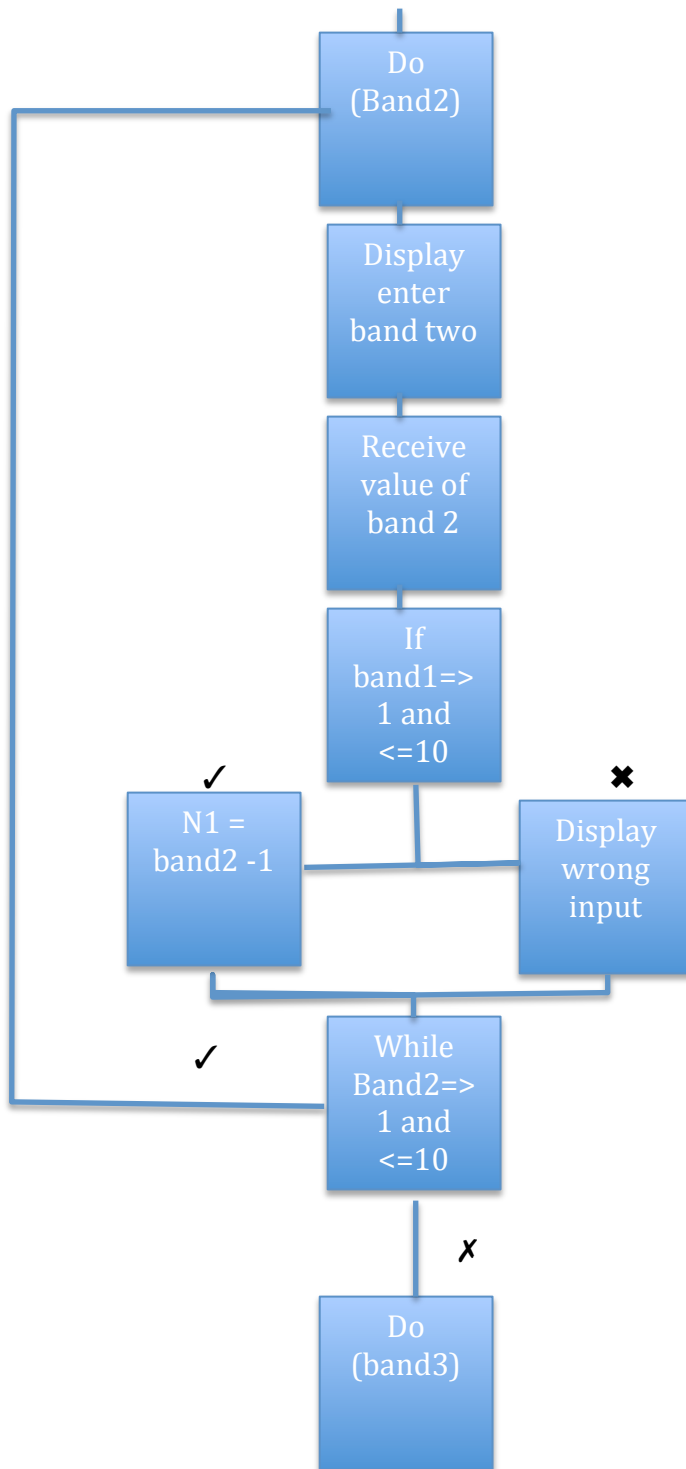

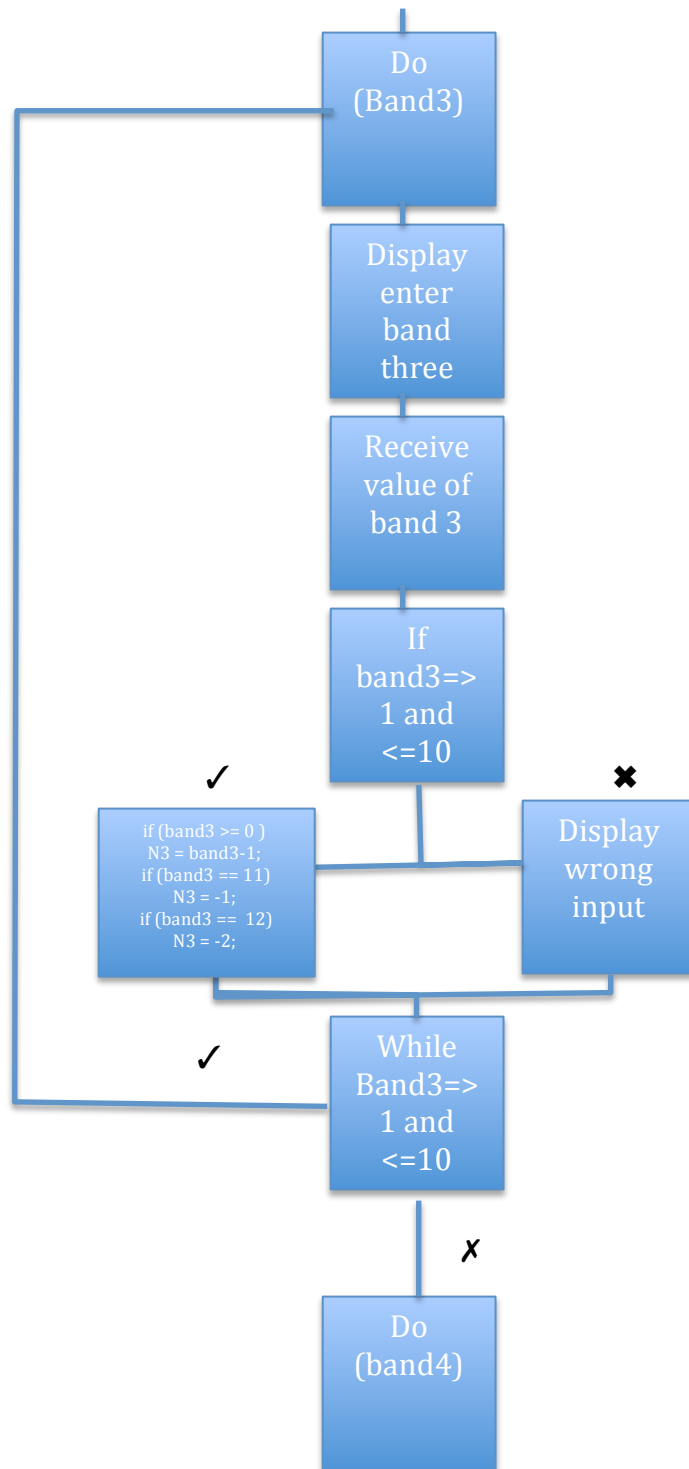

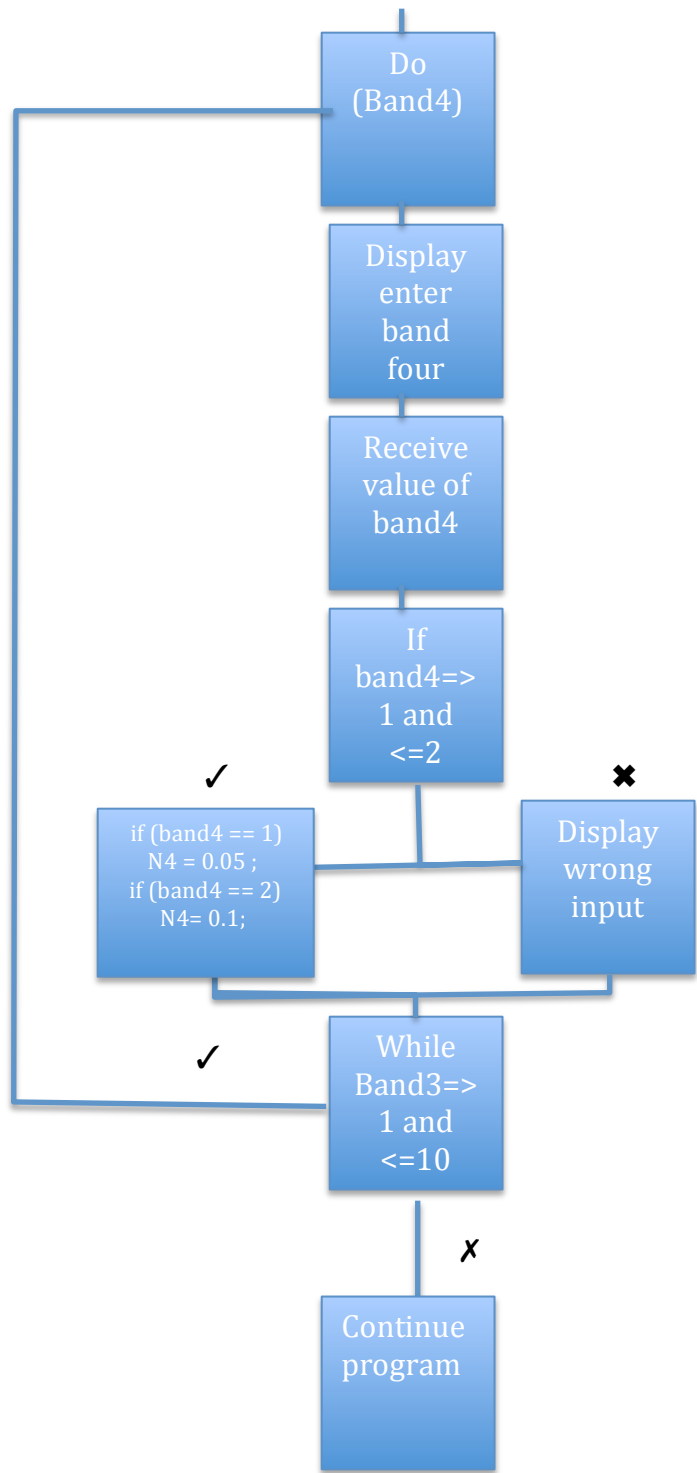

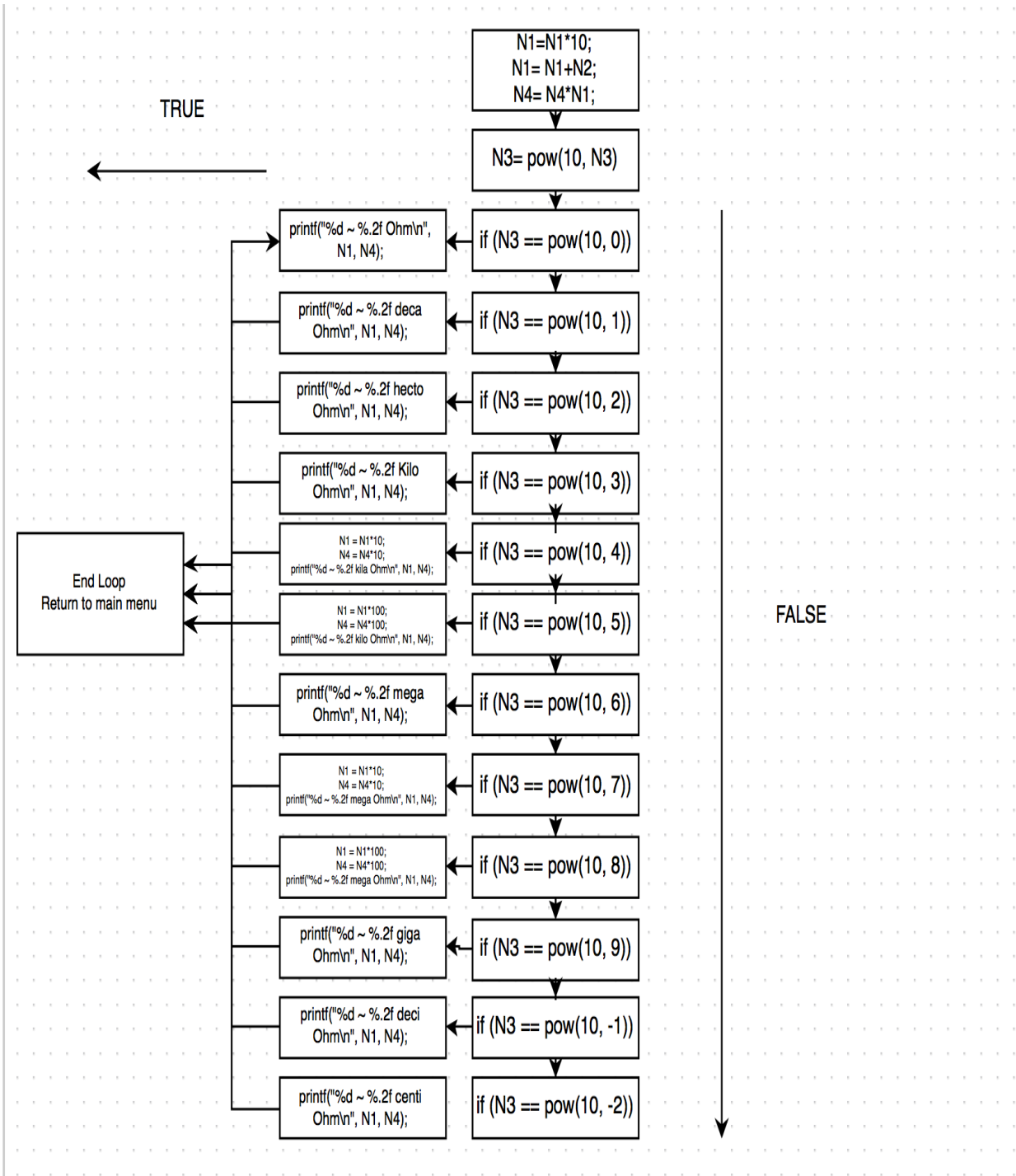

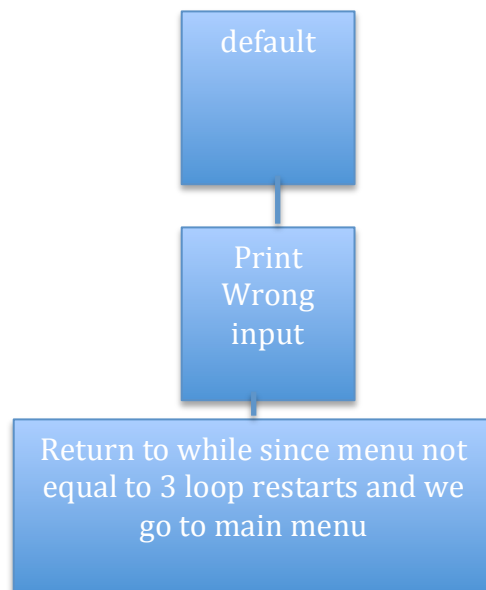
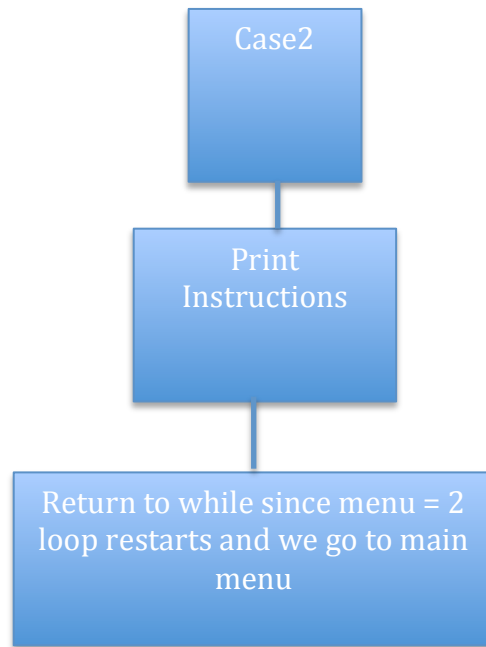

Step 4: separate File

Step 5:

```
minayoussef — assignment_2 — assignment_2 — 80x24
Select choice of third band (input number)
1=black
2=brown
3=red
4=orange
5=yellow
6=green
7=blue
8=voilet
9=gray
10=white
11=gold
12=sliver
3
Select choice of fourth band (input number)
1=gold
2=sliver
1
1 ~ 0.05 hecto Ohm
please choose an option:
1.Calculate resistance value
2.help
3.Exit
```

```
minayoussef — assignment_2 — 80x24
Last login: Fri Oct 17 14:10:47 on console
/Users/minayoussef/Google\ Drive/First\ Year/first\ semester/Eng\ Computation/as
signments/Assignment\ 2/assignment_2 ; exit;
Minas-MBP:~ minayoussef$ /Users/minayoussef/Google\ Drive/First\ Year/first\ sem
ester/Eng\ Computation/assignments/Assignment\ 2/assignment_2 ; exit;
please choose an option:
1.Calculate resistance value
2.help
3.Exit
2
Enter All four band colors using the corresponding number given,
if you input an invalid option you will be prompted to re-enter
the color valueplease choose an option:
1.Calculate resistance value
2.help
3.Exit
3
logout

[Process completed]
```

Question 1:

It will display 1,2,3,4 then the program will end. When it first enters the loop $i=1+1$ so the first output is 1, since its smaller than 3 it reenters the loop. It will repeat this until $i=4$ then the program ends because $4>3$ so the function is active and we leave the loop.

Question 2:

It will display 4,3,2,1,0 then the program will end. When it first enters the loop $i=i-1$ so the first output is 4, since its not yet equal to zero the Boolean value in the while loop is TRUE. The last time the loop runs $i=1$, in the loop we get $i=i-1$ which is equal to zero. Zero is then displayed, but after leaving the loop the Boolean value is now FALSE and the loop does not restart so the program ends.