

Board Question

1. For the mechanism shown in the *Figure below*, link 2 is the driving link with displacement angle of q and an angular velocity of q (q-dot). At the instant of consideration $q = 60^\circ$, and the links 3,4 and 5 make angles with the positive horizontal of 17° , 90° and 315° .

- If at this instant, the velocity V_C of the slider is $-10 i$ cm/sec, what is the necessary angular velocity q of the link 2.
- If q is constant at this instant (at the value calculated in part (a)), what is the acceleration a_C of the slider.

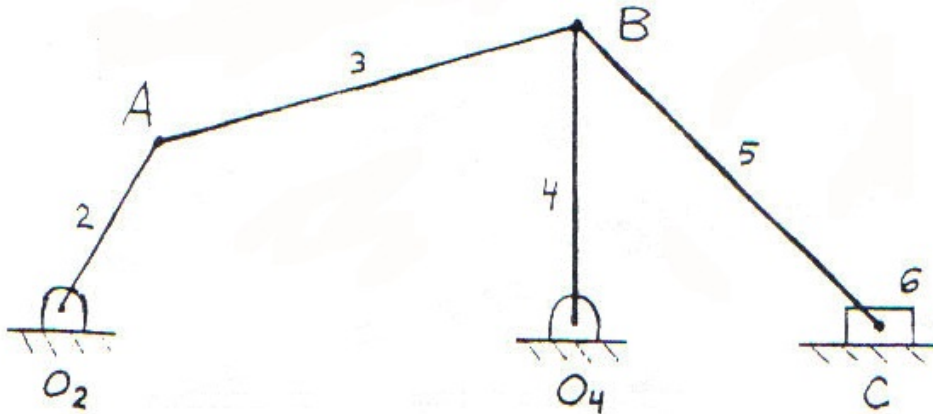

$$O_2 O_4 = 5 \text{ cm}, O_2 A = 2.0 \text{ cm}, AB = 4.2 \text{ cm}, O_4 B = 3.0 \text{ cm}, BC = 4.2 \text{ cm}$$

$O_2 O_4 = 5.0 \text{ cm}$
 $O_2 A = 2.0 \text{ cm}$
 $AB = 4.2 \text{ cm}$
 $O_4 B = 3.0 \text{ cm}$
 $BC = 4.2 \text{ cm}$

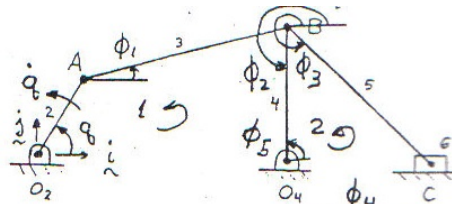

$O_2 O_4 = 5.0 \text{ cm}$
 $O_2 A = 2.0 \text{ cm}$
 $AB = 4.2 \text{ cm}$
 $O_4 B = 3.0 \text{ cm}$
 $BC = 4.2 \text{ cm}$
 $BC^2 = BO_4^2 + O_4C^2$
 $4.2^2 = 3^2 + \phi_4^2$
 $\phi_4 = 2.94$

SOLN:

(a) Loop 1 Closure eqns

$$2 \cos \theta + 4.2 \cos \phi_1 + 3 \cos \phi_2 - 5 = 0$$

$$2 \sin \theta + 4.2 \sin \phi_1 + 3 \sin \phi_2 = 0$$

Loop 2 Closure eqns

$$3 \cos \phi_5 + 4.2 \cos \phi_3 - \phi_4 = 0$$

$$3 \sin \phi_5 + 4.2 \sin \phi_3 = 0$$

Use $\left\{ \begin{array}{l} \phi_5 = \phi_2 - \pi \\ \phi_5 = \phi_2 \end{array} \right. \quad \begin{array}{l} \phi_1 = 17^\circ \quad \phi_3 = 315^\circ \\ \phi_2 = 270^\circ \quad \phi_4 = 2.94 \\ \theta = 60^\circ \end{array}$

The loops are weakly coupled, but the problem will be solved in one operation
 Diff w.r.t time (ϕ_1, ϕ_2, ϕ_3 and θ are unknown)

$$\begin{array}{l} (1) \quad -4.2 \sin \phi_1 \dot{\phi}_1 - 3 \sin \phi_2 \dot{\phi}_2 - 2 \sin \theta \dot{\theta} = 0 \\ (2) \quad 4.2 \cos \phi_1 \dot{\phi}_1 + 3 \cos \phi_2 \dot{\phi}_2 + 2 \cos \theta \dot{\theta} = 0 \\ (3) \quad -3 \sin \phi_5 \dot{\phi}_2 - 4.2 \sin \phi_3 \dot{\phi}_3 = \dot{\phi}_4 \\ (4) \quad 3 \cos \phi_5 \dot{\phi}_2 + 4.2 \cos \phi_3 \dot{\phi}_3 = 0 \end{array}$$

Use $\phi_1 = 17^\circ, \phi_2 = 270^\circ, \phi_3 = 315^\circ, \phi_4 = 2.94, \phi_5 = 90^\circ, \theta = 60^\circ, \dot{\phi}_4 = -10$

Solve simultaneously (4) eqns.

$$\dot{\phi}_1 = -1.76 \quad \dot{\phi}_2 = 3.33 \quad \dot{\phi}_3 = 0 \quad \dot{\theta} = 7.02 \quad \therefore \dot{\theta} = 7.02 \text{ rad/s}$$

(b) Diff w.r.t time $\ddot{\phi}_1, \ddot{\phi}_2, \ddot{\phi}_3, \ddot{\phi}_4$ are unknown

$$\begin{array}{l} (1) \quad -4.2 \sin \phi_1 \ddot{\phi}_1 - 3 \sin \phi_2 \ddot{\phi}_2 = 2 \sin \theta \ddot{\theta} + 2 \cos \theta (\dot{\theta})^2 + 4.2 \cos \phi_1 (\dot{\phi}_1)^2 + 3 \cos \phi_2 (\dot{\phi}_2)^2 \\ (2) \quad 4.2 \cos \phi_1 \ddot{\phi}_1 + 3 \cos \phi_2 \ddot{\phi}_2 = -2 \cos \theta \ddot{\theta} + 2 \sin \theta (\dot{\theta})^2 + 4.2 \sin \phi_1 (\dot{\phi}_1)^2 + 3 \sin \phi_2 (\dot{\phi}_2)^2 \\ (3) \quad -3 \sin \phi_5 \ddot{\phi}_2 - 4.2 \sin \phi_3 \ddot{\phi}_3 - \ddot{\phi}_4 = 3 \cos \phi_5 (\dot{\phi}_2)^2 + 4.2 \cos \phi_3 (\dot{\phi}_3)^2 \\ (4) \quad 3 \cos \phi_5 \ddot{\phi}_2 + 4.2 \cos \phi_3 \ddot{\phi}_3 = 3 \sin \phi_5 (\dot{\phi}_2)^2 + 4.2 \sin \phi_3 (\dot{\phi}_3)^2 \end{array}$$

Insert position values $\phi_1, \phi_2, \phi_3, \phi_4, \theta$, and velocity values $\dot{\phi}_1, \dot{\phi}_2, \dot{\phi}_3, \dot{\phi}_4$ from above and $\dot{\theta}$:

Solve simultaneously $\Rightarrow \ddot{\phi}_4 = +45.7 \text{ cm/s}^2 \quad \therefore a_C = -45.7 \text{ cm/s}^2$

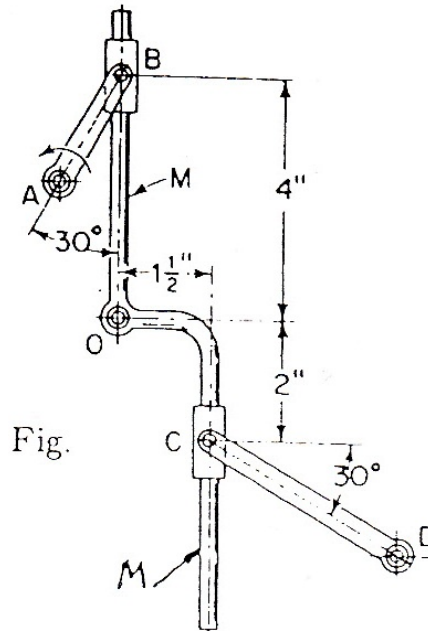

Fig.

In the mechanism of Fig. , M is a rigid member turning freely about fixed axis O. Crank AB (2 in. long) turns about fixed axis A. AB has a counterclockwise angular velocity of 1.5 radians/sec, and a counterclockwise angular acceleration of 2.0 radians/sec². Link CD (3.6 in. long) turns about fixed axis D. Sleeves sliding freely on M are pinned to AB and CD at B and C. For the instant shown determine

- (a) the angular velocities of M and CD,
- (b) the angular acceleration of M.

Solution:

1. Loop ABOA

$$2 \cos \theta + \phi_1 \cos \phi_2 + r_{Ox} = 0$$

$$2 \sin \theta + \phi_1 \sin \phi_2 + r_{Oy} = 0$$

$$\begin{cases} \dot{\phi}_1 \cos \phi_2 - \phi_1 \dot{\phi}_2 \sin \phi_2 = 2 \dot{\theta} \sin \theta \\ \dot{\phi}_1 \sin \phi_2 + \phi_1 \dot{\phi}_2 \cos \phi_2 = -2 \dot{\theta} \cos \theta \end{cases}$$

$$0 \dot{\phi}_1 + 4 \dot{\phi}_2 = 2.6$$

$$- \dot{\phi}_1 + 0 = -1.5$$

$$AB = 2$$

$$\theta = 60^\circ$$

$$\phi_2 = 270^\circ$$

$$\dot{\theta} = 1.5$$

$$\phi_1 = 4$$

$$\omega_M \equiv \dot{\phi}_2$$

$$\dot{\phi}_2 = 0.65 \text{ rad/s}$$

$$\dot{\phi}_1 = 1.5$$

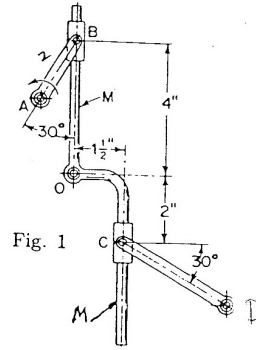
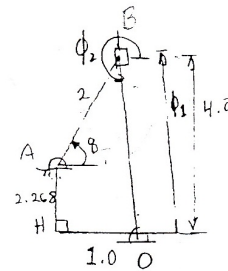

Fig. 1



Loop OKCO

$$1.5 \cos \bar{\theta} + \phi_3 \cos (\bar{\theta} + 270^\circ) + 3.6 \cos \phi_4 + R_{Ox} = 0$$

$$1.5 \sin \bar{\theta} + \phi_3 \sin (\bar{\theta} + 270^\circ) + 3.6 \sin \phi_4 + R_{Oy} = 0$$

$$\begin{cases} \dot{\phi}_3 \cos (270^\circ) - 3.6 \dot{\phi}_4 \sin 330^\circ = 1.5 \sin 0^\circ \dot{\bar{\theta}} + 2 \sin 270^\circ \dot{\bar{\theta}} \\ \dot{\phi}_3 \sin 270^\circ + 3.6 \dot{\phi}_4 \cos 330^\circ = -1.5 \cos 0^\circ \dot{\bar{\theta}} - 2 \cos 270^\circ \dot{\bar{\theta}} \end{cases}$$

$$- \dot{\phi}_3 + 1.8 \dot{\phi}_4 = -1.3$$

$$- \dot{\phi}_3 + 3.118 \dot{\phi}_4 = -0.975$$

$$\dot{\phi}_4 = -0.722 \text{ rad/s}$$

$$\omega_{CD}$$

$$CD = 3.6$$

$$\phi_3 = 2 \quad \bar{\theta} = 0^\circ$$

$$\phi_4 = 330^\circ \quad \dot{\bar{\theta}} = 0.65 \quad \ddot{\bar{\theta}} = 0$$

Diff *

$$\begin{cases} \ddot{\phi}_1 \cos \phi_2 - \phi_1 \ddot{\phi}_2 \sin \phi_2 = 2 \ddot{\theta} \sin \theta + 2 \dot{\theta}^2 \cos \theta + \dot{\phi}_1 \dot{\phi}_2 \sin \phi_2 + \phi_1 \dot{\phi}_2 \sin \phi_2 + \phi_1 \dot{\phi}_2^2 \cos \phi_2 \\ \ddot{\phi}_1 \sin \phi_2 + \phi_1 \ddot{\phi}_2 \cos \phi_2 = -2 \ddot{\theta} \cos \theta + 2 \dot{\theta}^2 \sin \theta - \dot{\phi}_1 \dot{\phi}_2 \cos \phi_2 - \phi_1 \dot{\phi}_2 \cos \phi_2 + \phi_1 \dot{\phi}_2^2 \sin \phi_2 \end{cases}$$

$$0 \ddot{\phi}_1 + 4 \ddot{\phi}_2 = 2(2)(1.866) + 2(1.5)^2(1.5) + (1.5)(1.65)(-1)2 + 4(1.65)^2(0)$$

$$4 \ddot{\phi}_2 = 3.764$$

$$\ddot{\phi}_2 = 0.941 \text{ rad/s}^2$$

1.49