

Lecture 6 – Boolean Algebra and Logic Gates– Part II

Rami Abielmona
University of Ottawa
January 30, 2015
ITI 1100 B
Digital Systems I

Presentation Outline

- Sum of Products (SOP)
- Product of Sums (POS)
- Minterms and Maxterms
- Two-level and Multi-level Implementations
- Examples
- Simplification and Derivation
- Key terms

Standard Forms

- We have seen how to interpret truth tables, obtain Boolean expressions (functions) then build logic circuits.
 - We have simplified Boolean expressions using Boolean algebra.
- There is a “standard” way of writing Boolean expressions (Functions):**
- **The standard Sum of Products (SOP)**
 - **The standard Product of Sums (POS)**

The standard Sum of Product-Minterms

- A Minterm is one in which all variables appear (only) once.
- Each Minterm represents exactly one combination (row) in truth table.
- n variables give 2^n Minterms.

Truth Table

Decimal value	A	B	C	F	Minterm
0	0	0	0	0	m_0
1	0	0	1	0	m_1
2	0	1	0	1	m_2
3	0	1	1	1	m_3
4	1	0	0	1	m_4
5	1	0	1	1	m_5
6	1	1	0	1	m_6
7	1	1	1	1	m_7

The standard Sum of Products-Function

- SOP are expressions of the form:

$$F(A,B,C, \dots) = (\dots) + (\dots) + (\dots) + \dots$$

- Brackets can contain single or multiple variables
- Such expressions can be implemented using:

$$F(A,B,C, \dots) = (\text{AND's}) \text{ OR } (\text{AND's}) \text{ OR } (\text{AND's}) \text{ OR } \dots$$

The standard Sum of Product-Function

- SOP form not unique, and doesn't necessarily contain all variables, for example:

$$F(A,B,C) = A'B'C' + A'BC + C'A'B + C'AB' + BAC + BAC$$

and $F(A,B,C) = B + B'C'$

are both valid SOP expressions.

The standard Sum of Product-Function

- We Can obtain SOP from truth table (below)

$$F(A,B,C) = A'BC' + A'BC + AB'C' + AB'C + ABC' + ABC$$

A simpler notation is to write as

$$F(A,B,C) = m_2 + m_3 + m_4 + m_5 + m_6 + m_7$$

$$= \sum m_i (2, 3, 4, 5, 6, 7)$$

Decimal value	A	B	C	F	Minterm	
0	0	0	0	0	m_0	$A'B'C'$
1	0	0	1	0	m_1	$A'B'C$
2	0	1	0	1	m_2	$A'BC'$
3	0	1	1	1	m_3	$A'BC$
4	1	0	0	1	m_4	$AB'C'$
5	1	0	1	1	m_5	$AB'C$
6	1	1	0	1	m_6	ABC'
7	1	1	1	1	m_7	ABC

Canonical Form Representation

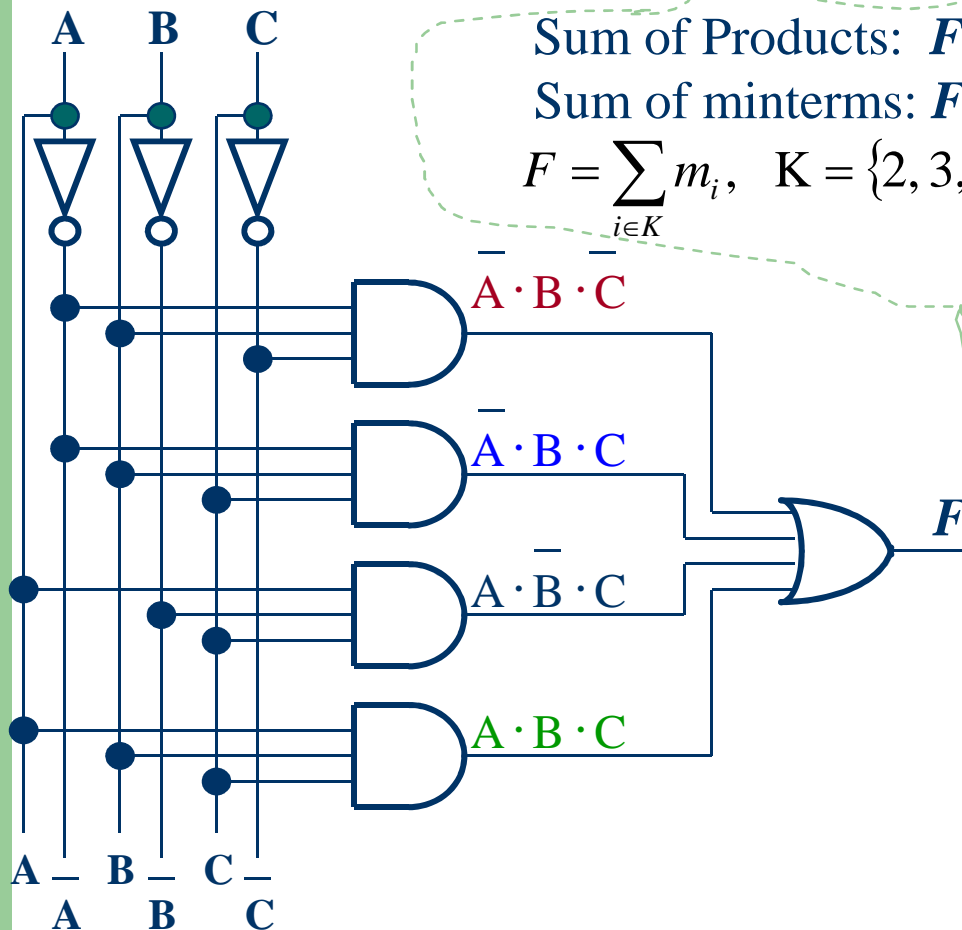

Sum of Products: $F = \bar{A}BC + A\bar{B}C + A\bar{B}\bar{C} + ABC$
 Sum of minterms: $F = (m_2, m_3, m_5, m_7)$
 $F = \sum_{i \in K} m_i, K = \{2, 3, 5, 7\} ; F = (2, 3, 5, 7)$

term	min- A	B	C	F
(m ₀)	0	0	0	0
(m ₁)	0	0	1	0
(m ₂)	0	1	0	1
(m ₃)	0	1	1	1
(m ₄)	1	0	0	0
(m ₅)	1	0	1	1
(m ₆)	1	1	0	0
(m ₇)	1	1	1	1

Product of Sums Function

• From truth table we have

$$F(A,B,C) = (A'B'C' + A'B'C)$$

• Therefore we obtain F from \bar{F} :

$$\begin{aligned} F(A,B,C) &= \overline{\overline{F(A,B,C)}} = \overline{(A'B'C' + A'B'C)} \\ &= (A' + B'' + C'') \cdot (A'' + B'' + C') = (A + B + C) \cdot (A + B + C') \end{aligned}$$

Form Compact $F = M_0 \cdot M_1 = \prod M_i (0, 1)$

Truth Table

Decimal value	A	B	C	F	Minterm	Maxterm	$M_i = \bar{m}_i$
0	0	0	0	0	m_0	M_0	$A+B+C$
1	0	0	1	0	m_1	M_1	$A+B+C'$
2	0	1	0	1	m_2	M_2	$A+B'+C$
3	0	1	1	1	m_3	M_3	$A+B'+C'$
4	1	0	0	1	m_4	M_4	$A'+B+C$
5	1	0	1	1	m_5	M_5	$A'+B+C'$
6	1	1	0	1	m_6	M_6	$A'+B'+C$
7	1	1	1	1	m_7	M_7	$A'+B'+C'$

Obtain SOP and POS from a given expression

- Given an arbitrary Boolean expression
- Work out number of terms (2^n) for n inputs.
- Generate truth table and identify terms for which the function is true - the Minterms.

- Write function as:
$$F = \sum_{i=0}^{n-1} m_i$$

- Alternatively, identify terms for which the function is false and use a Maxterm description.

- Write function :

$$F = \prod_{j=0}^{n-1} M_j \quad j \neq i$$

SOP & POS Implementation using AND and OR

- Two-level implementation

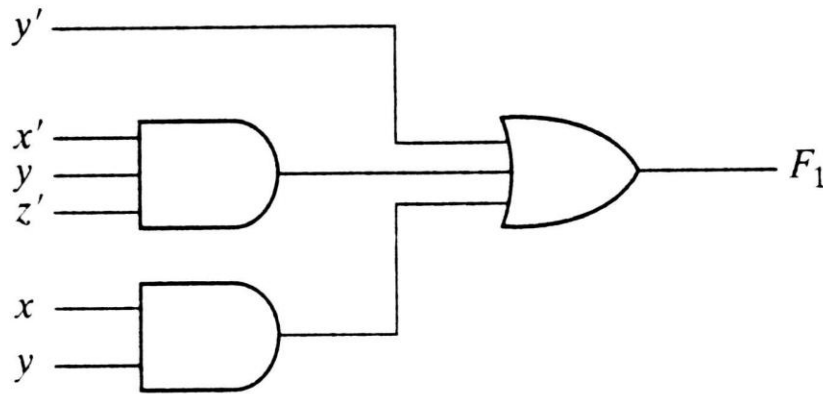

(a) Sum of Products

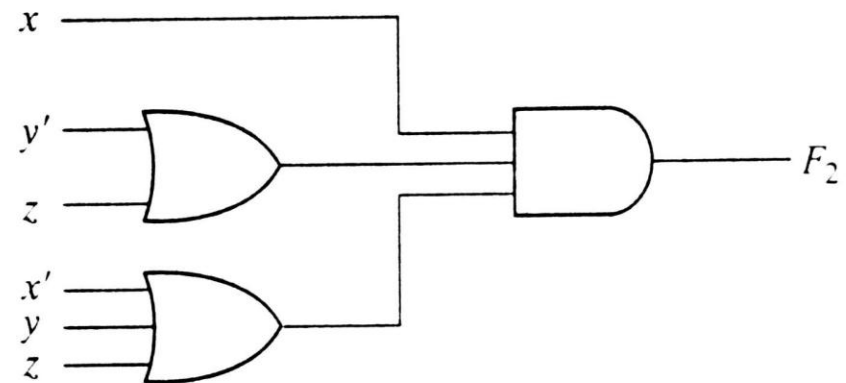

(b) Product of Sums

- Multi-level implementation

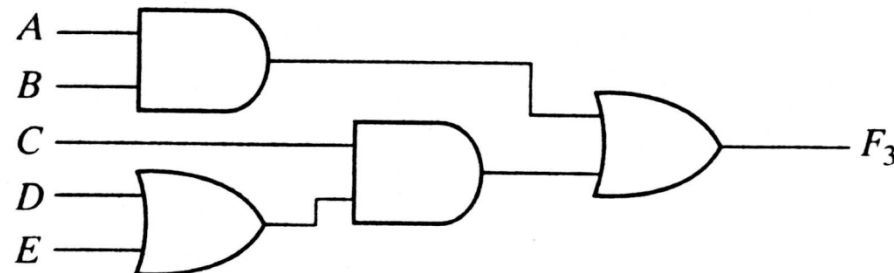

(a) $AB + C(D + E)$

Examples

1- Half Adder

2- Full Adder

3- Deriving SOP and POS from a truth table

4- Simplifying SOP & POS using Boolean identities

Half Adder

→ The half-adder accepts two binary digits on its inputs and produces two binary digits on its outputs: a sum bit and a carry bit.

Truth Table			
A	B	C	S
0	0	0	0
0	1	0	1
1	0	0	1
1	1	1	0

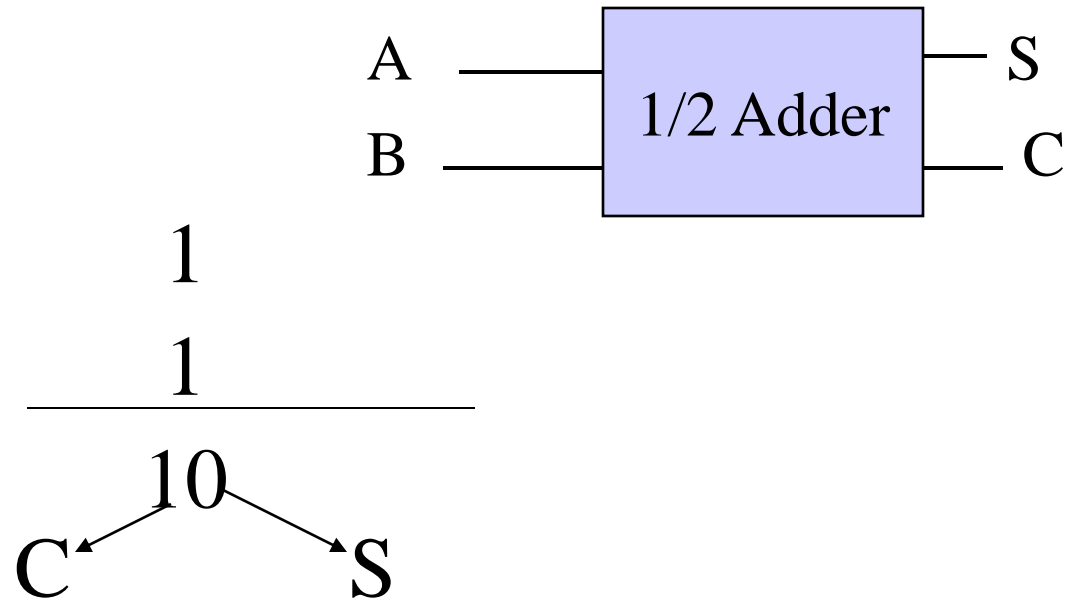

Half-Adder

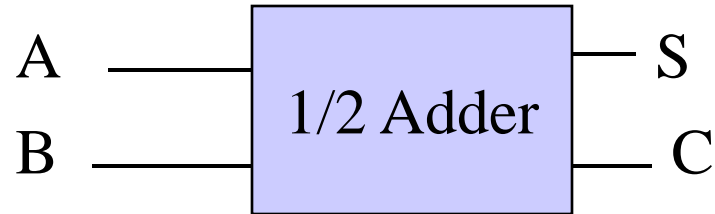

Truth Table

A	B	C	S
0	0	0	0
0	1	0	1
1	0	0	1
1	1	1	0

Logic Function

$$S = A'B + AB'$$

$$S = A \oplus B$$

$$C = A.B$$

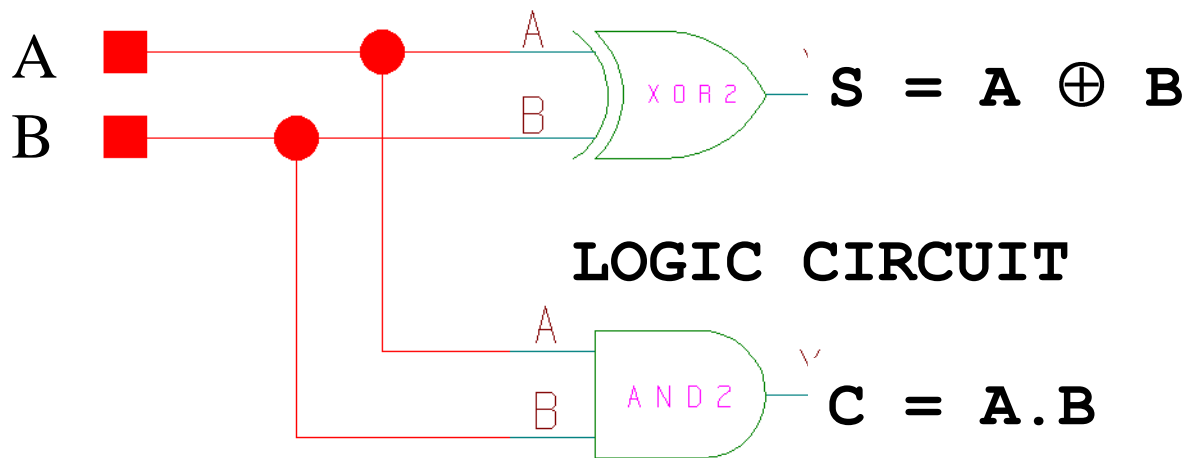

Full Adder

Truth Table

A	B	C	C_o	S
0	0	0	0	0
0	0	1	0	1
0	1	0	0	1
0	1	1	1	0
1	0	0	0	1
1	0	1	1	0
1	1	0	1	0
1	1	1	1	1

→ The Full-adder accepts two input bits and an input carry and generates a sum output and an output carry

→ Basic difference between a full and a half adder is that the full adder **accepts an input carry**



Full-Adder

Logic FUNCTION

Truth Table

A	B	C	C _o	S
0	0	0	0	0
0	0	1	0	1
0	1	0	0	1
0	1	1	1	0
1	0	0	0	1
1	0	1	1	0
1	1	0	1	0
1	1	1	1	1

$$\begin{aligned}C_o &= A'BC + AB'C + ABC' + ABC \\&= C[A'B + AB'] + AB[C' + C] \\&= C[A \oplus B] + AB.1 \\&= C(A \oplus B) + AB\end{aligned}$$

$$\begin{aligned}S &= A'B'C + A'BC' + AB'C' + ABC \\&= A'[B'C + BC'] + A[B'C' + BC] \\&= A'[B \oplus C] + A[B \oplus C]' \\&= A' \overset{[X]}{X} + A \overset{[X]'}{X'} \\&= A \oplus X \\&= A \oplus B \oplus C\end{aligned}$$

Full Adder

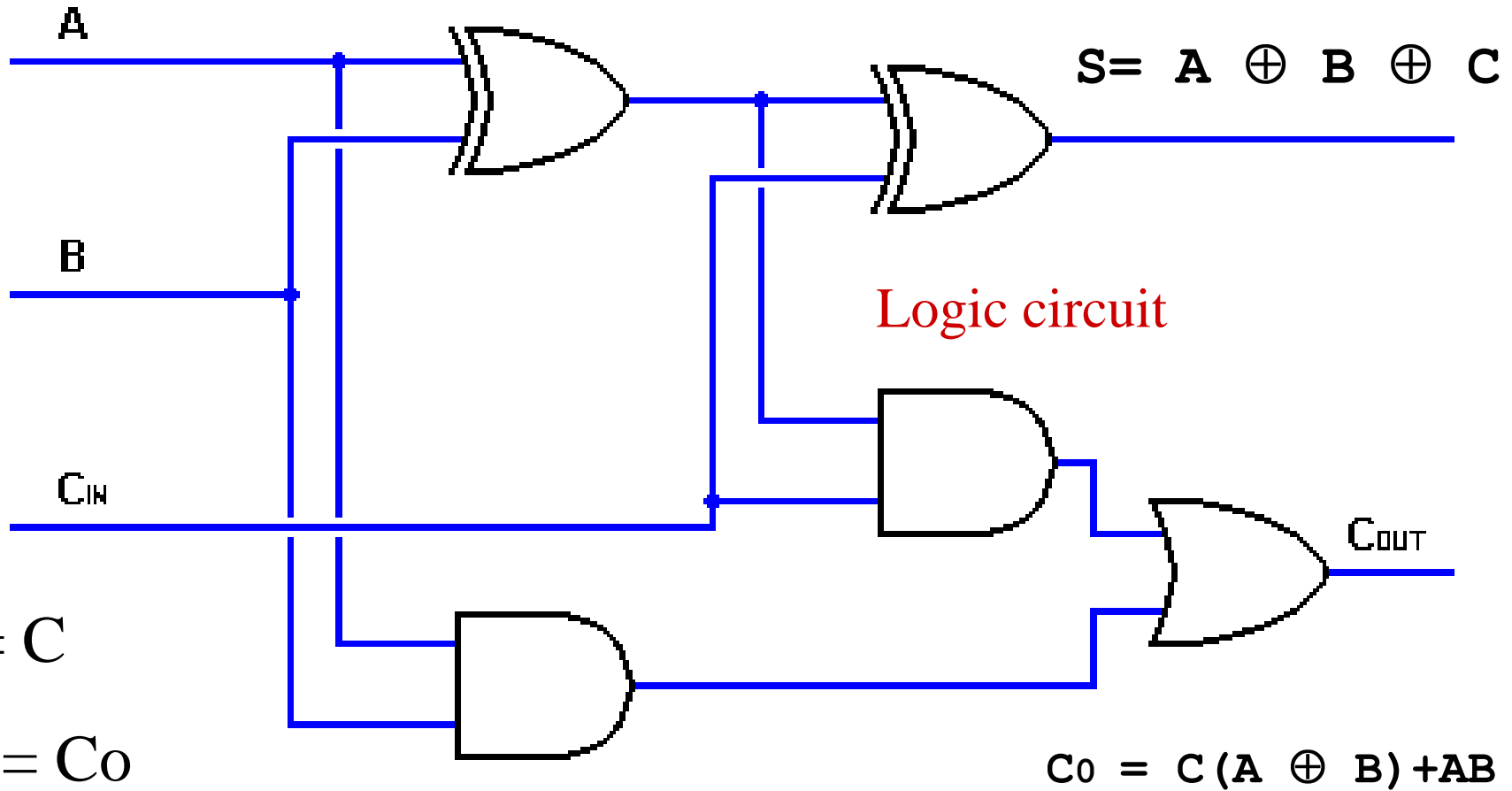

Two bit parallel adder

$$\begin{array}{r} \mathbf{1} \leftarrow \text{Carry bit from right column} \\ 1\ 1 \\ +\ 0\ 1 \\ \hline \end{array}$$

$$\mathbf{1}\ 0\ 0$$

Carry bit from second column
becomes a sum bit

Two bit parallel adder

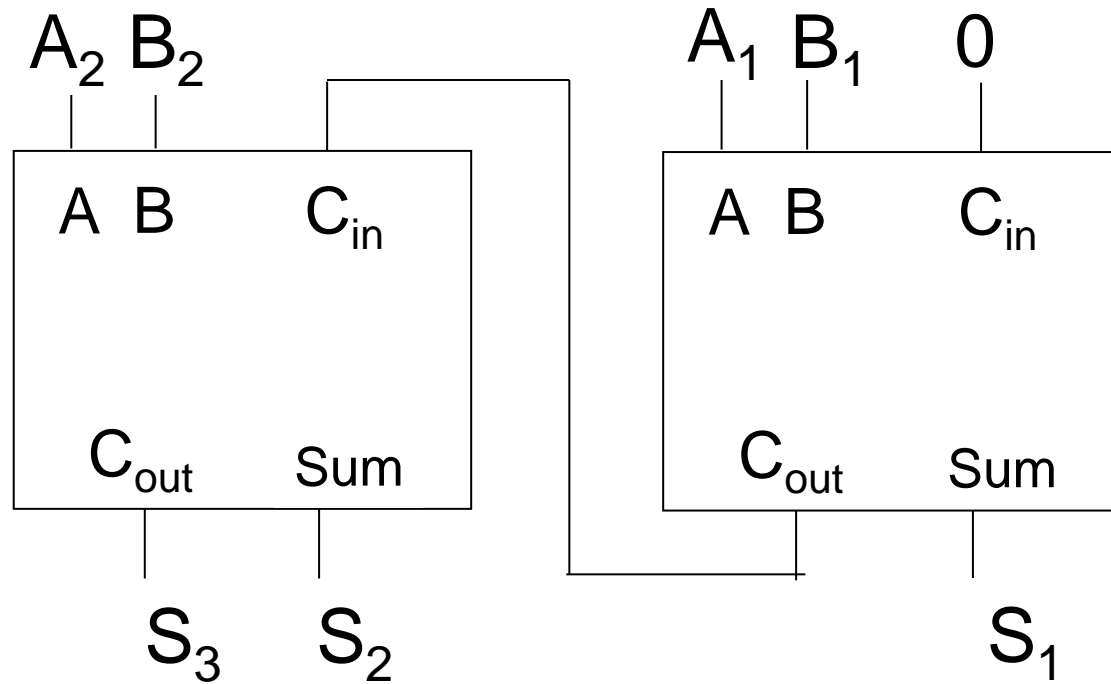

$$\begin{array}{r} A_2 A_1 \\ + B_2 B_1 \\ \hline S_3 S_2 S_1 \end{array}$$

Four bit parallel adder

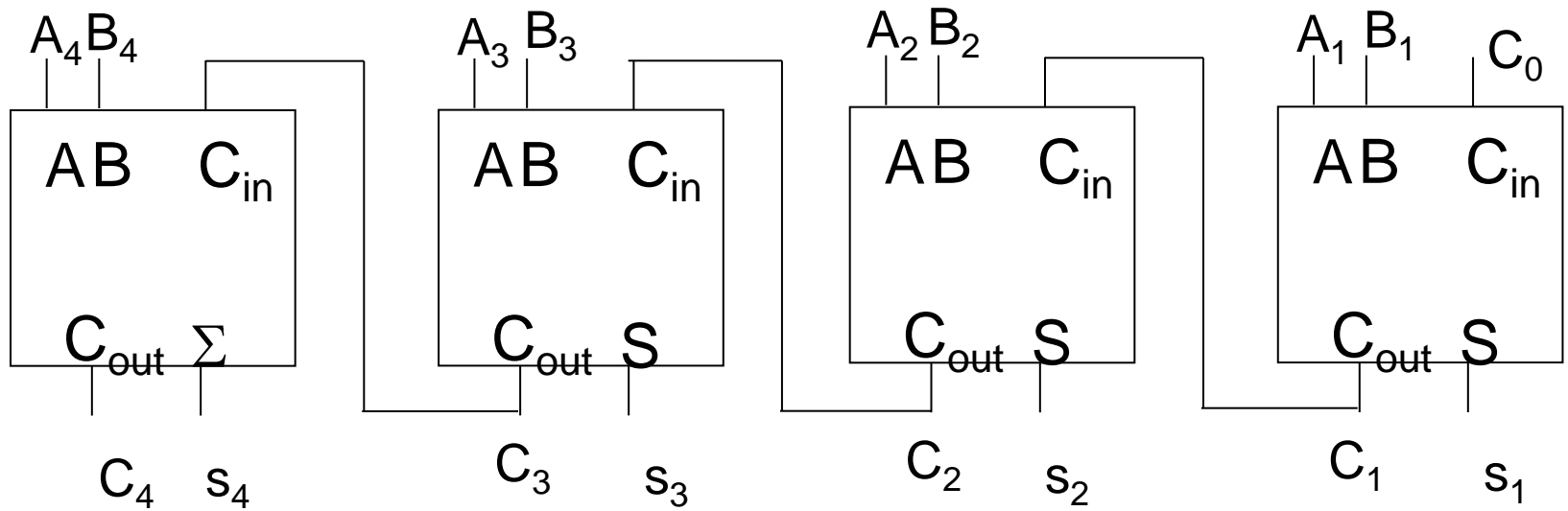

Overflow Examples (review from chapter 1)

- In a 6-bit register

$$+ 17 = \quad 010001$$

$$+ 16 = \quad +\underline{010000}$$

$$= 100001 \quad \rightarrow \text{Overflow}$$

- **100001 = 2's : - (11111) = -(31)₁₀ instead of + (33)₁₀**
- Same with a 7-bit register

$$+ 17 = \quad 0\ 010001$$

$$+ 16 = \quad +\underline{0\ 010000}$$

$$= 0\ 100001$$

$$\mathbf{0100001 = + 33 \text{ No Overflow}}$$

Four bit parallel adder

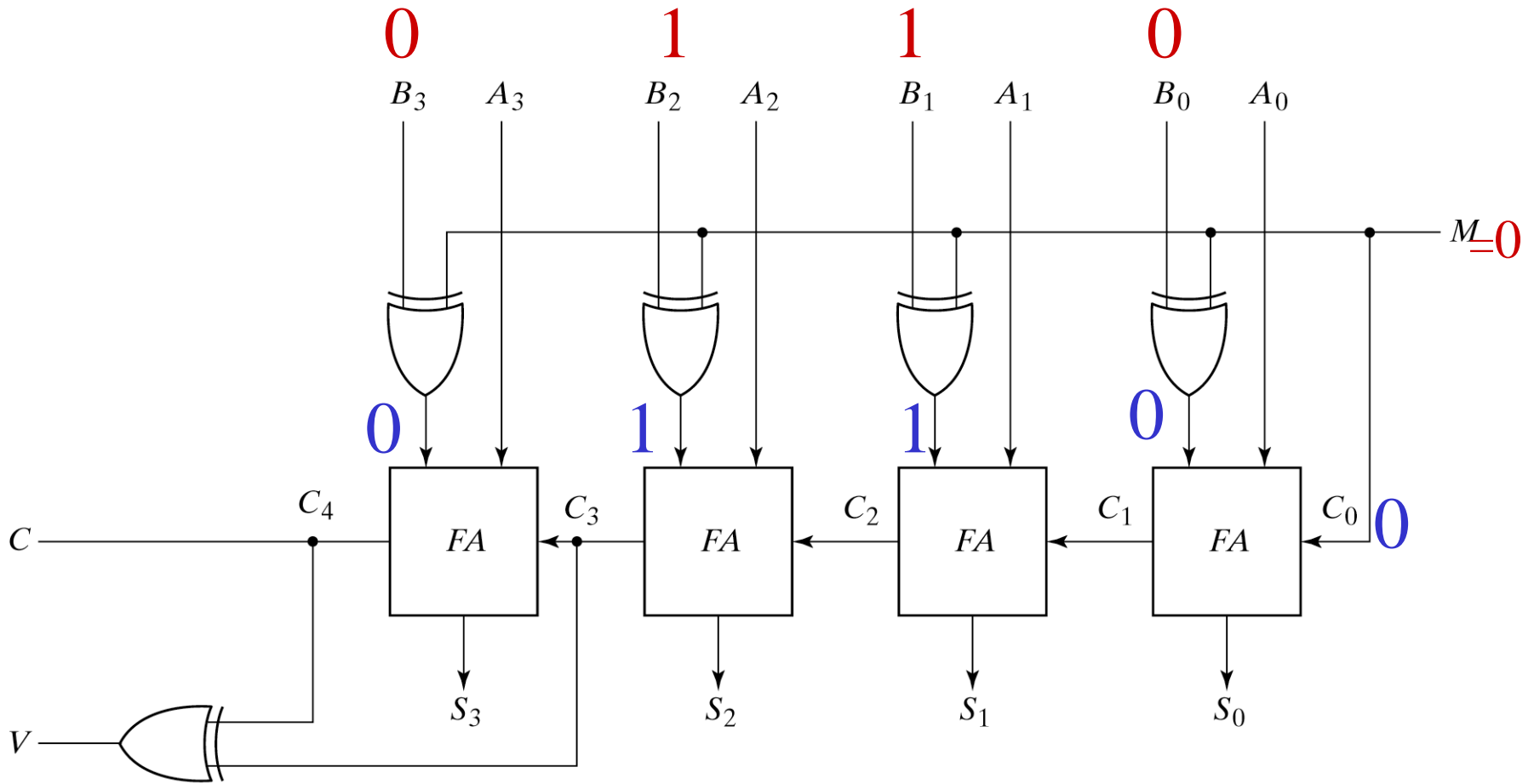

Fig. 4-13 4-Bit Adder Subtractor

Four bit parallel adder

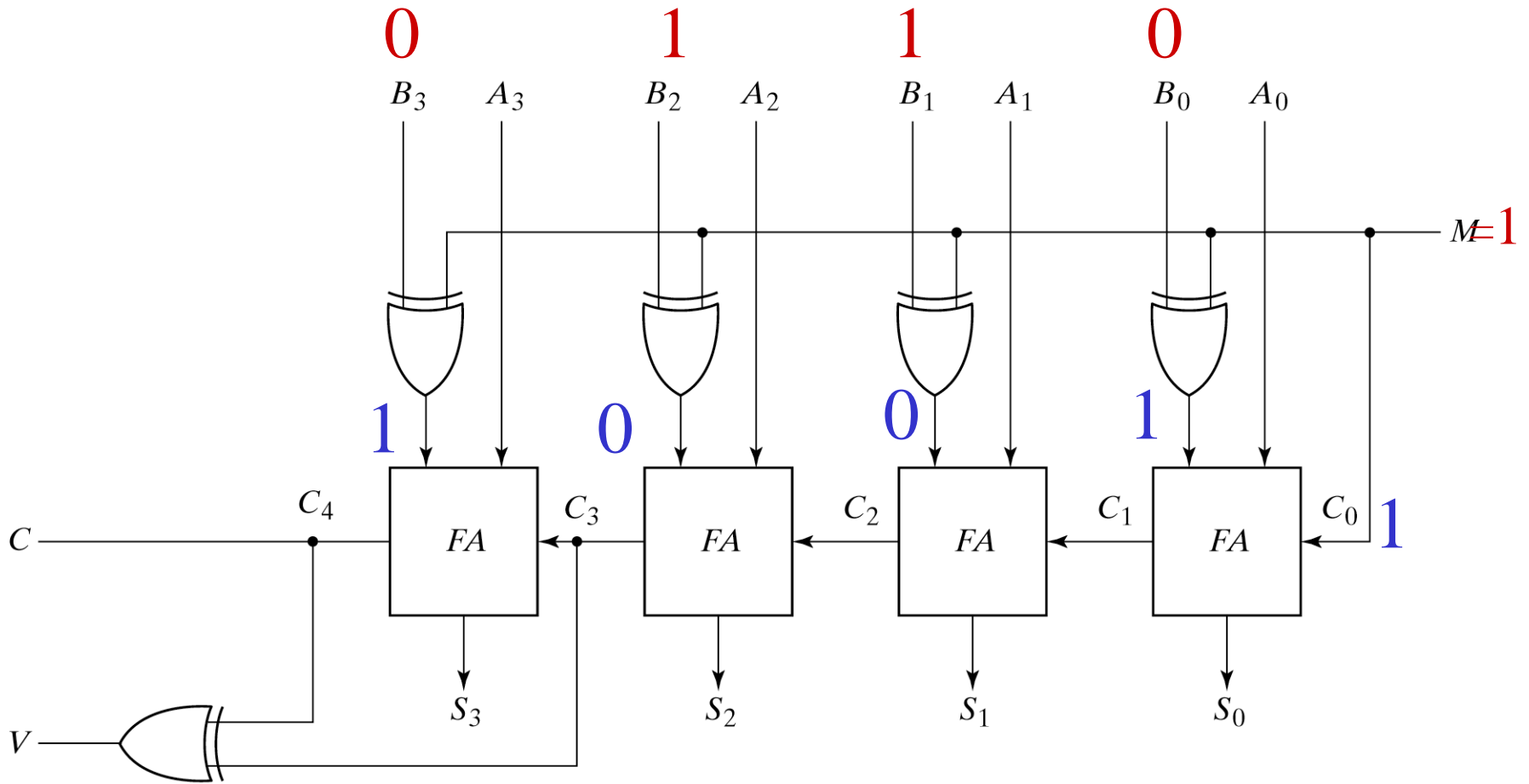

Fig. 4-13 4-Bit Adder Subtractor

Four bit parallel adder: more examples

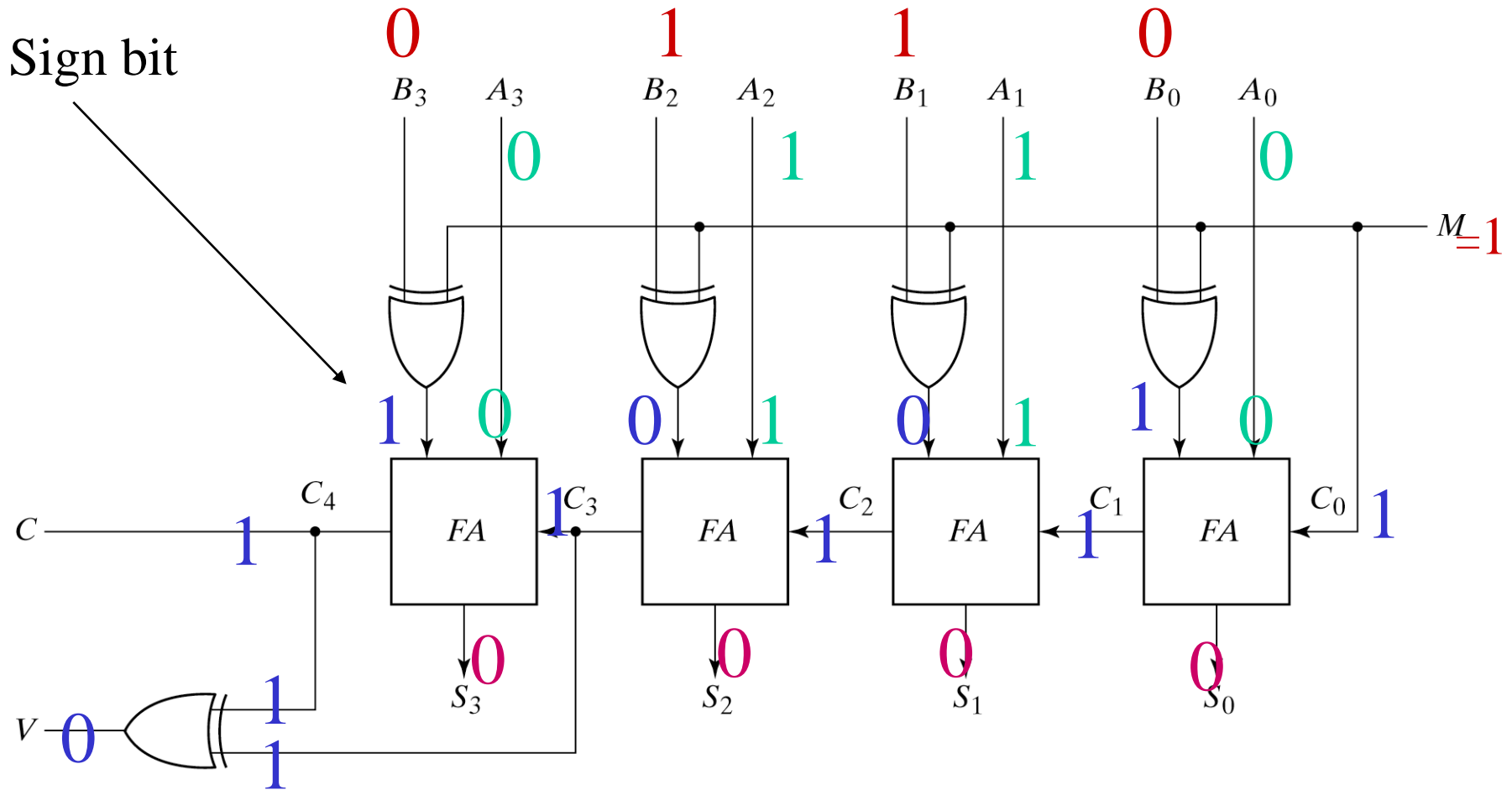

Fig. 4-13 4-Bit Adder Subtractor

SOP & POS Standard Forms- Example

From an arbitrary Truth table (next slide)

- **Part one**

- 1- obtain SOP representation for F

- 2- obtain the two level implementation for F without simplification

- 3- simplify F using Boolean identities

- 4- obtain two level-implementation for F

- 5- compare the design obtained in question 4 with the one of question 2

- **Part two**

Repeat part one using POS

Deriving SOP and POS from a truth table

Consider the following arbitrary Truth Table

i) SOP

ii) POS

i	A	B	C	F	Minterms
0	0	0	0	0	
1	0	0	1	0	
2	0	1	0	1	$\rightarrow m_2 = A'BC'$
3	0	1	1	1	$\rightarrow m_3 = A'BC$
4	1	0	0	0	
5	1	0	1	1	$\rightarrow m_5 = AB'C$
6	1	1	0	0	
7	1	1	1	1	$\rightarrow m_7 = ABC$

Deriving SOP from a truth table

1- Expression sum of products

$$\begin{aligned} \text{a) } F &= m_2 + m_3 + m_5 + m_7 \\ &= A'BC' + A'BC + AB'C + ABC \end{aligned}$$

b) Implementation with logic gates (unsimplified)

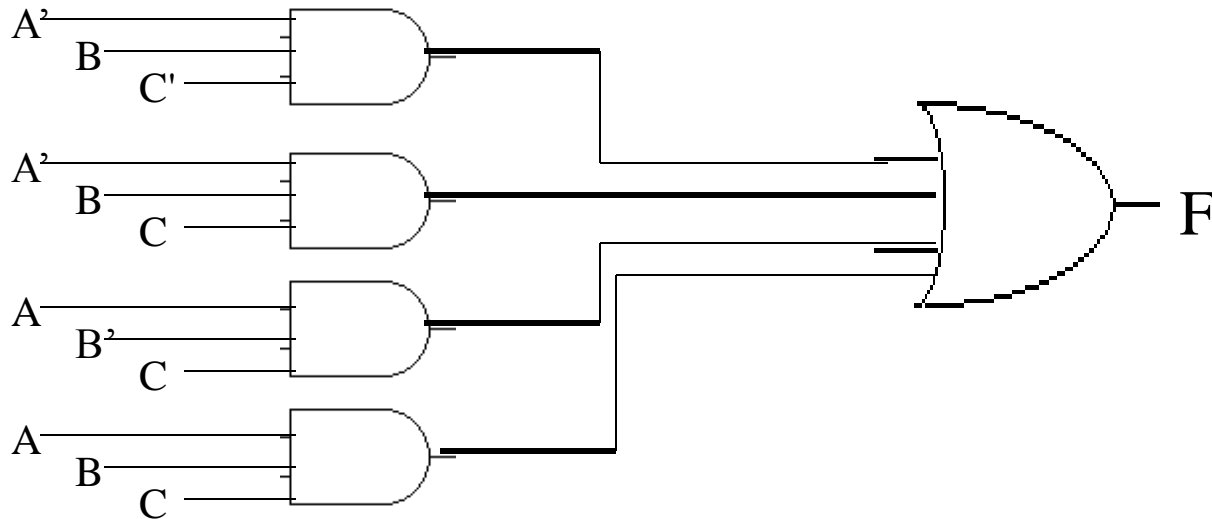

Two level-Implementation

Simplifying SOP using Boolean identities

c) Simplification

Using the Boolean identity absorption $xy + xy' = x$

We can simplify m_2 with m_3 and m_5 with m_7

$$m_2 + m_3 = (A'B)C' + (A'B)C = A'B$$

$$m_5 + m_7 = (AC)B' + (AC)B = AC$$

Therefore $F = A'B + AC$

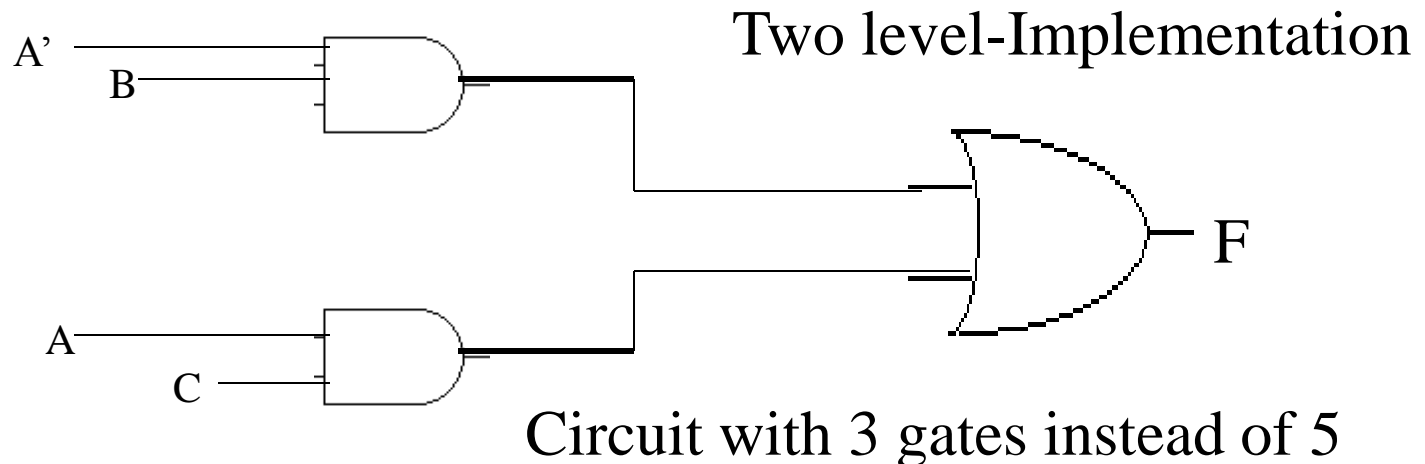

Deriving POS from a truth table

2- Expression Product of sums

i	A	B	C	F	Maxterms
0	0	0	0	0	$\rightarrow M_0 = A+B+C$
1	0	0	1	0	$\rightarrow M_1 = A+B+C'$
2	0	1	0	1	
3	0	1	1	1	
4	1	0	0	0	$\rightarrow M_4 = A'+B+C$
5	1	0	1	1	
6	1	1	0	0	$\rightarrow M_6 = A'+B'+C$
7	1	1	1	1	

Deriving SOP from a truth table

a) Function

$$F = M_0 \cdot M_1 \cdot M_4 \cdot M_6$$

$$= (A+B+C) (A+B+C')(A'+B+C)(A'+B'+C)$$

Logic circuit

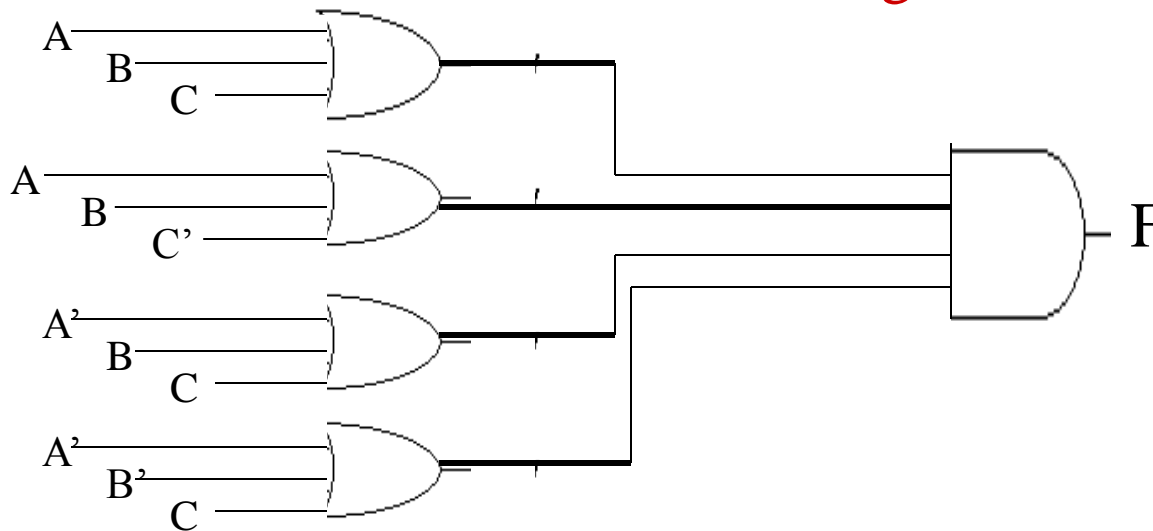

Two level-Implementation

Simplifying POS using Boolean identities

b) Simplification

Using $(X + Y) (X+Y') = X$

Verification

X	Y	Y'	X+ Y	X + Y'	(X + Y) (X+Y')
0	0	1	0	1	0
0	1	0	1	0	0
1	0	1	1	1	1
1	1	0	1	1	1

$$M0.M1 = [(A+B) + C] [(A+B) + C'] = \mathbf{A+B}$$

$$M4.M6 = [A' + C) + B] [(A'+C) + B'] = \mathbf{A'+C}$$

$$\mathbf{F = (A+B)(A'+C)}$$

Simplifying POS using Boolean identities

C) Two level Implementation

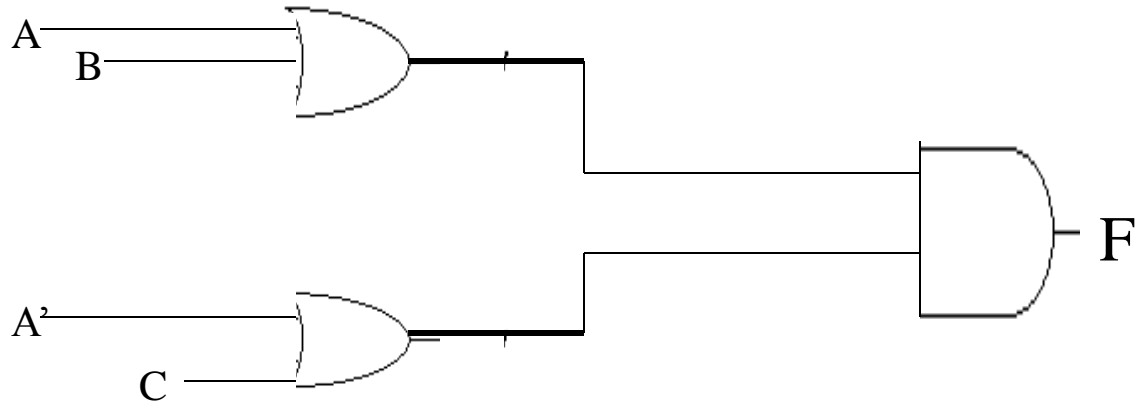

Key Terms and Review Points

- Boolean Expression
 - Canonical Form
 - Derivation from a Truth Table
 - Full Adder
 - Half-Adder
 - Maxterm
 - Minterm
 - Multi-level Implementation
 - Parallel Adder
 - Products of Sums
 - Single-level Implementation
 - Simplification using Boolean Identities
 - Sum of Products
 - Truth Table
-
- References: Dr. Karmouch and Dr. Groza ITI 1100 Slides