

## GNG 1105 - ENGINEERING MECHANICS

Final Exam

Duration: 3 Hour

December 11, 2013

Page 1 of 3

Profs. A. Skaff, Y. Haddad, Ph. Girault, and A. Ahmed

-----  
**Closed book Examination. Only non-programmable calculators are allowed.  
All other electronic devices are not allowed.**

**Solve ONLY four out of the five problems indicated below.**  
-----

### **Problem1. (25/100)**

A  $1\text{ m} \times 2\text{ m}$  sign of uniform density weighs  $1.2\text{ KN}$  is held in place by a ball-and-socket support at point A and by two cables EB and DC.

- Write the tensions in cables EB and DC in vector form.
- Determine the tensions in cables EB and DC.

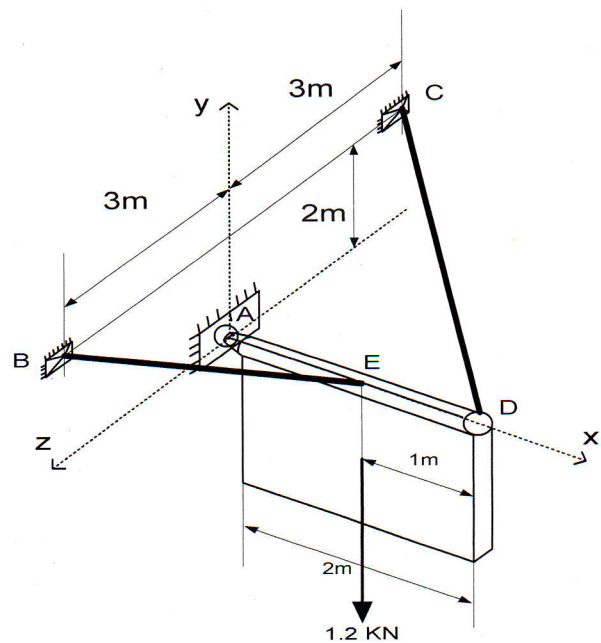

**Problem2. (25/100)**

The truss shown to the right is supported by a pin joint at A and a cable at point B.

- Determine the reaction at A and the tension in BH.
- Find the tension or compression in members FD, GD, and GE by the method of sections.

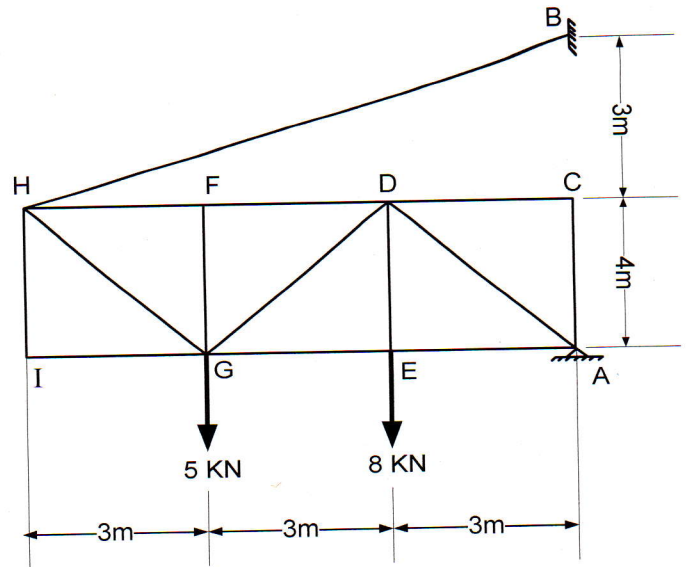

**Problem3. (25/100)**

Lever ABC is attached to a pin joint at C and to a link BD as shown. A force of 500 N is being applied at point A as shown.

- Draw the free-body diagrams of lever ABC and link BD, as being disassembled from each other.
- Find all the forces acting on lever ABC.

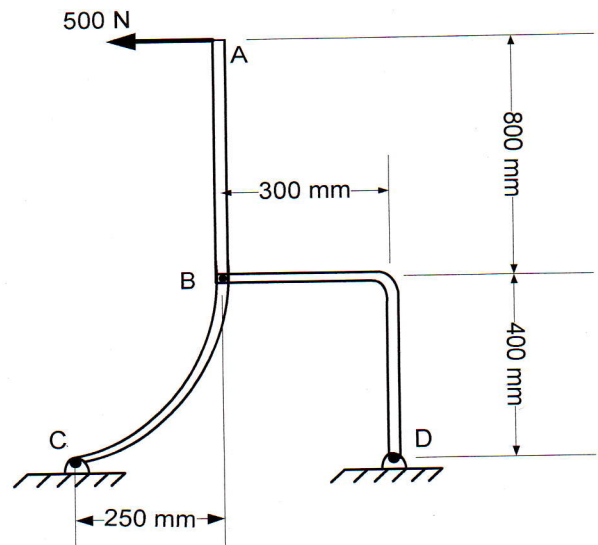

**Problem4. (25/100)**

Block A is of mass 20kg and block B is of mass 5kg. The coefficient of static friction between block B and the vertical wall and block A and the floor is  $\mu_{s1}=0.30$ , and the coefficient of static friction between the two blocks A&B is  $\mu_{s2}=0.20$ . Determine the force P necessary for impending motion of block A.

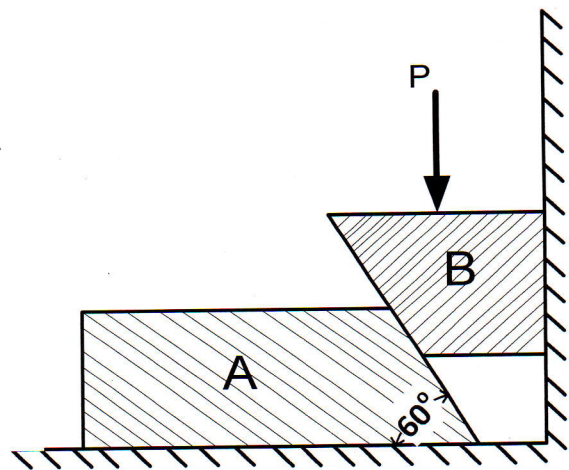

**Problem 5. Parts (a) and (b) are independent. (25/100)**

a) An airplane begins to take-off on the runway at point A with zero velocity and a constant acceleration  $a$ . Knowing that it will take off 30s later at point B and that the distance AB is 900m, determine (a) the acceleration  $a$ , (b) the take-off velocity  $v_B$ .

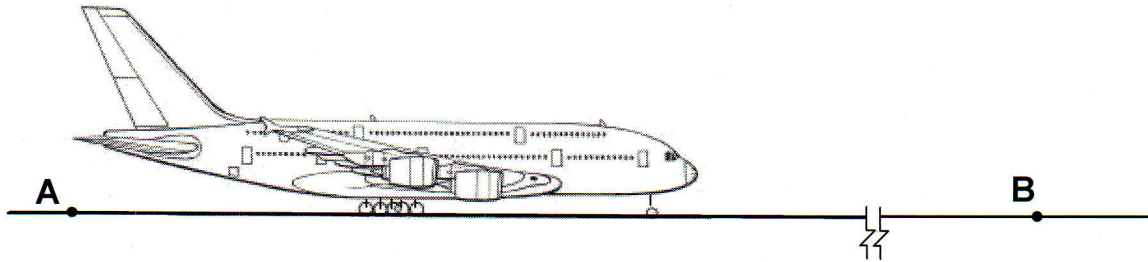

b) A basketball player threw the ball from point A with an initial velocity  $v_o$ , which makes  $60^\circ$  with the horizontal. It falls through a hoop at B. Determine the initial velocity  $v_o$  of the ball ( $g=9.81 \text{ m/s}^2$ ).

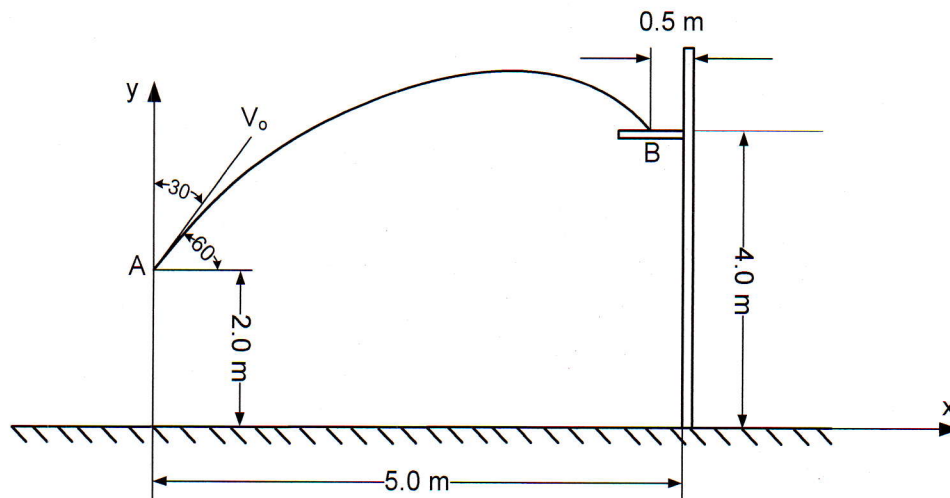

**Useful Equations**

$$x = x_o + vt$$

$$v = v_o + at$$

$$x = x_o + v_o t + \frac{1}{2} at^2$$

$$v^2 = v_o^2 + 2a(x - x_o)$$

$$\sum \vec{F} = m\vec{a}$$

$$\sum \vec{F}_x = m\vec{a}_x \quad , \quad \sum \vec{F}_y = m\vec{a}_y \quad , \quad \sum \vec{F}_z = m\vec{a}_z$$