

PEER ASSISTED STUDY SESSIONS

Facil: Hailey Quiquero

Course: ECOR 1101 A

Week: 4 – October 7& 8

Email: hailey.quiquero@carleton.ca

Office: ML 409

Office Hours: Tues. 4:30-5:30

MOCK MIDTERM 1

Use this mock midterm to assess your preparedness for the upcoming midterm. Aim to complete it under exam-like conditions, and within a 3 hour time limit. Solutions **will not** be posted online. The questions will be taken up in the workshops on October 7th and 8th. **Try all questions ahead of time** – we will only have time to go through the solutions and I will be asking students for help. **I am here to help you understand the concepts, not to simply write the solutions on the board.**

Good luck!

Workshop Rooms TBD – Watch cuLearn for updates!

DISCLAIMER: PASS worksheets are designed as a study aid only for use in PASS workshops. Worksheets may contain errors, intentional or otherwise. It is up to the student to verify the information contained within.

PLEASE NOTE: THIS HANDOUT IS NOT TO BE DISTRIBUTED.

Source: R.C. Hibbeler. Engineering Mechanics: 12th Edition. Pearson Prentice Hall, Pearson Education.

PEER ASSISTED STUDY SESSIONS

Facil: Hailey Quiquero

Course: ECOR 1101 A

Week: 4 – October 7& 8

Email: hailey.quiquero@carleton.ca

Office: ML 409

Office Hours: Tues. 4:30-5:30

***2–52.** If the magnitude of the resultant force acting on the bracket is to be 450 N directed along the positive u axis, determine the magnitude of F_1 and its direction ϕ .

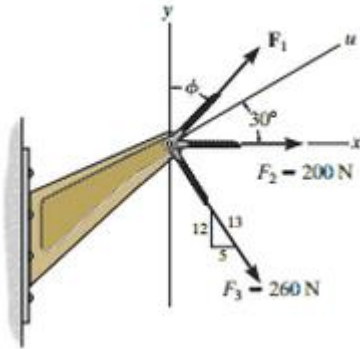

DISCLAIMER: PASS worksheets are designed as a study aid only for use in PASS workshops. Worksheets may contain errors, intentional or otherwise. It is up to the student to verify the information contained within.

PLEASE NOTE: THIS HANDOUT IS NOT TO BE DISTRIBUTED.

Source: R.C. Hibbeler. Engineering Mechanics: 12th Edition. Pearson Prentice Hall, Pearson Education.

PEER ASSISTED STUDY SESSIONS

Facil: Hailey Quiquero
 Email: hailey.quiquero@carleton.ca

Course: ECOR 1101 A
 Office: ML 409

Week: 4 – October 7& 8
 Office Hours: Tues. 4:30-5:30

3–66. The bucket has a weight of 80 lb and is being hoisted using three springs, each having an unstretched length of $l_0 = 1.5$ ft and stiffness of $k = 50$ lb/ft. Determine the vertical distance d from the rim to point A for equilibrium.

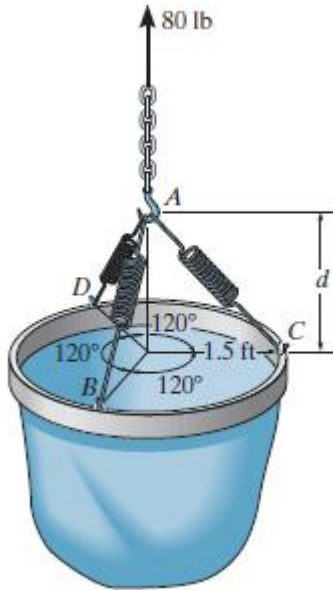

DISCLAIMER: PASS worksheets are designed as a study aid only for use in PASS workshops. Worksheets may contain errors, intentional or otherwise. It is up to the student to verify the information contained within. PLEASE NOTE: THIS HANDOUT IS NOT TO BE DISTRIBUTED.

Source: R.C. Hibbeler. Engineering Mechanics: 12th Edition. Pearson Prentice Hall, Pearson Education.

PEER ASSISTED STUDY SESSIONS

Facil: Hailey Quiquero
Email: hailey.quiquero@carleton.ca

Course: ECOR 1101 A
Office: ML 409

Week: 4 – October 7& 8
Office Hours: Tues. 4:30-5:30

4–59. The friction at sleeve A can provide a maximum resisting moment of $125 \text{ N}\cdot\text{m}$ about the x axis. Determine the largest magnitude of force F that can be applied to the bracket so that the bracket will not turn.

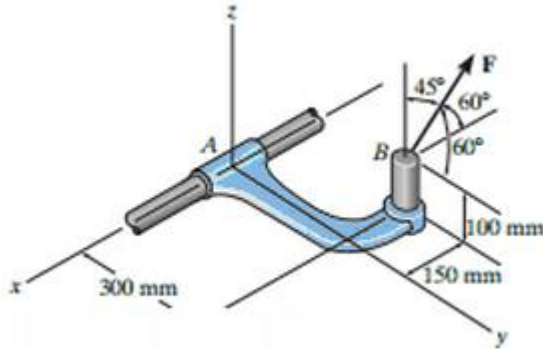

DISCLAIMER: PASS worksheets are designed as a study aid only for use in PASS workshops. Worksheets may contain errors, intentional or otherwise. It is up to the student to verify the information contained within.
PLEASE NOTE: THIS HANDOUT IS NOT TO BE DISTRIBUTED.

Source: R.C. Hibbeler. Engineering Mechanics: 12th Edition. Pearson Prentice Hall, Pearson Education.

PEER ASSISTED STUDY SESSIONS

Facil: Hailey Quiquero
 Email: hailey.quiquero@carleton.ca

Course: ECOR 1101 A
 Office: ML 409

Week: 4 – October 7& 8
 Office Hours: Tues. 4:30-5:30

4-99. Determine the distance d between A and B so that the resultant couple moment has a magnitude of $M_R = 20 \text{ N} \cdot \text{m}$.

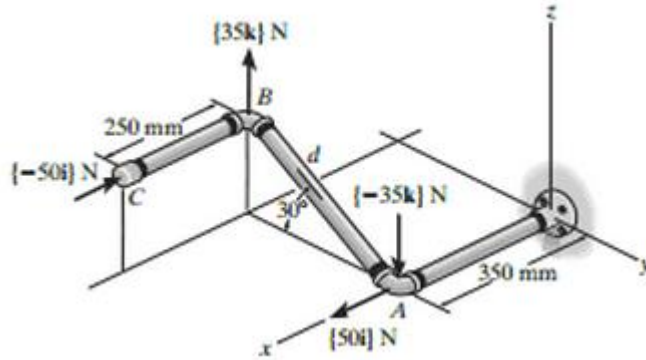

DISCLAIMER: PASS worksheets are designed as a study aid only for use in PASS workshops. Worksheets may contain errors, intentional or otherwise. It is up to the student to verify the information contained within. PLEASE NOTE: THIS HANDOUT IS NOT TO BE DISTRIBUTED.

Source: R.C. Hibbeler. Engineering Mechanics: 12th Edition. Pearson Prentice Hall, Pearson Education.

PEER ASSISTED STUDY SESSIONS

Facil: Hailey Quiquero
Email: hailey.quiquero@carleton.ca

Course: ECOR 1101 A
Office: ML 409

Week: 4 – October 7& 8
Office Hours: Tues. 4:30-5:30

4-111. Replace the force system by a resultant force and couple moment at point *O*.

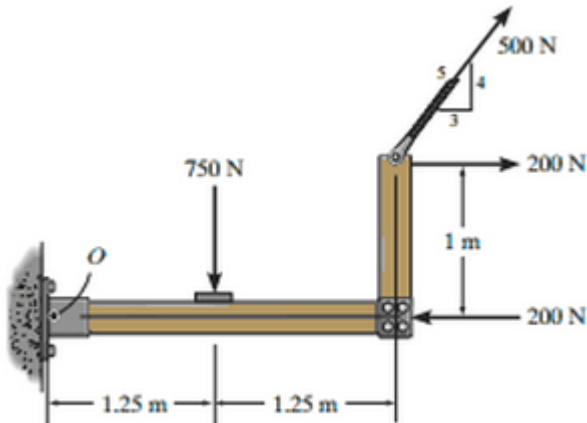

DISCLAIMER: PASS worksheets are designed as a study aid only for use in PASS workshops. Worksheets may contain errors, intentional or otherwise. It is up to the student to verify the information contained within.
PLEASE NOTE: THIS HANDOUT IS NOT TO BE DISTRIBUTED.

Source: R.C. Hibbeler. Engineering Mechanics: 12th Edition. Pearson Prentice Hall, Pearson Education.