

Lecture 13

- * EQUATIONS OF EQUILIBRIUM
- * CONSTRAINTS FOR A RIGID BODY

Section 6.6-6.7

Ehab Zalok

Objective:

Students will be able to:

- Identify support reactions in 3-D and draw a free body diagram, and,
- apply the equations of equilibrium.



2

EQUATIONS OF EQUILIBRIUM

(Section 5.6)

As stated earlier, when a body is in equilibrium, the net force and the net moment equal zero, i.e., $\sum \mathbf{F} = 0$ and $\sum \mathbf{M}_O = 0$.

These two vector equations can be written as six scalar equations of equilibrium (EofE). These are

$$\sum F_X = \sum F_Y = \sum F_Z = 0$$

$$\sum M_X = \sum M_Y = \sum M_Z = 0$$

The moment equations can be determined about any point. Usually, choosing the point where the maximum number of unknown forces are present simplifies the solution. Those forces do not appear in the moment equation since they pass through the point. Thus, they do not appear in the equation.

3

CONSTRAINTS FOR A RIGID BODY

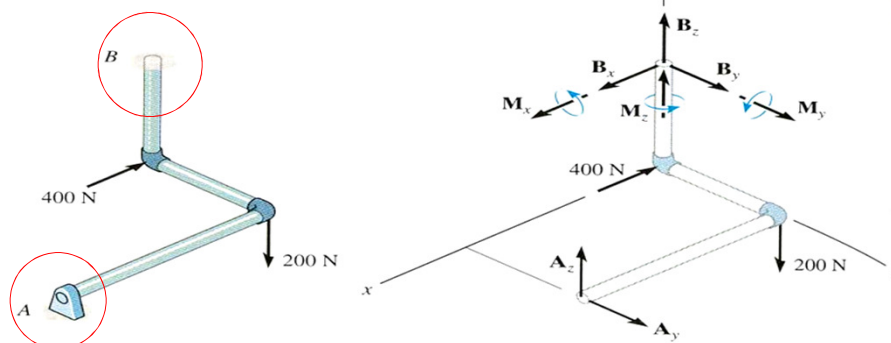

Redundant Constraints: When a body has more supports than necessary to hold it in equilibrium, it becomes statically indeterminate.

A problem that is statically indeterminate has more unknowns than equations of equilibrium.

Are statically indeterminate structures used in practice? Why or why not?

4

IMPROPER CONSTRAINTS

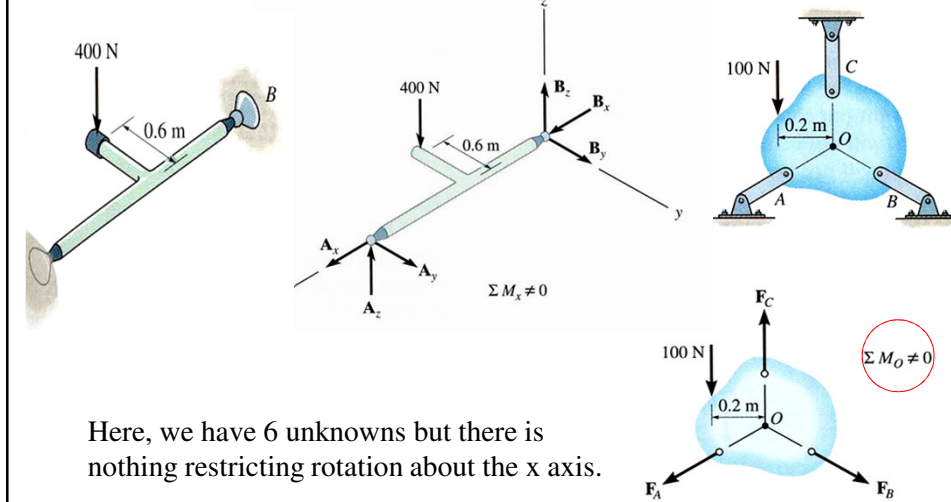

Here, we have 6 unknowns but there is nothing restricting rotation about the x axis.

In some cases, there may be as many unknown reactions as there are equations of equilibrium. However, if the supports are not properly constrained, the body may become unstable for some loading cases.

5

EXAMPLE

Given: The cable of the tower crane is subjected to 840 N force. A fixed base at A supports the crane.

Find: Reactions at the fixed base A.

Plan:

- a) Establish the x, y and z axes.
- b) Draw a FBD of the crane.
- c) Write the forces using Cartesian vector notation.
- d) Apply the equations of equilibrium (vector version) to solve for the unknown forces.

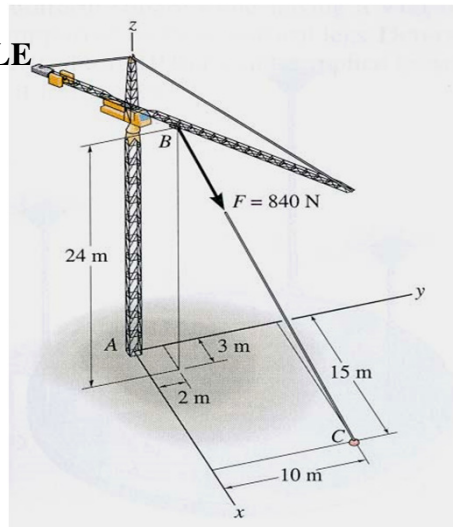

6

EXAMPLE
(continued)

$$r_{BC} = \{12\mathbf{i} + 8\mathbf{j} - 24\mathbf{k}\} \text{ m}$$

$$\mathbf{F} = F[\mathbf{u}_{BC}] \text{ N}$$

$$= 840 [12\mathbf{i} + 8\mathbf{j} - 24\mathbf{k}] / (12^2 + 8^2 + (-24)^2)^{1/2}$$

$$= \{360\mathbf{i} + 240\mathbf{j} - 720\mathbf{k}\} \text{ N}$$

$$\mathbf{F}_A = \{A_x\mathbf{i} + A_y\mathbf{j} + A_z\mathbf{k}\} \text{ N}$$

7

EXAMPLE
(continued)

From E-of-E we get, $\mathbf{F} + \mathbf{F}_A$

$$\{(360 + A_x)\mathbf{i} + (240 + A_y)\mathbf{j} + (-720 + A_z)\mathbf{k}\} = 0$$

Solving each component equation yields $A_x = -360 \text{ N}$,
 $A_y = -240 \text{ N}$, and $A_z = 720 \text{ N}$.

8

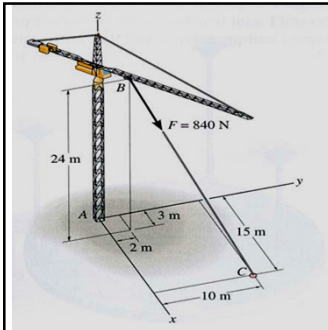

EXAMPLE (continued)

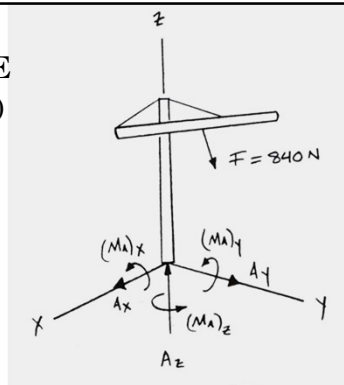

Sum the moments acting at point A.

$$\begin{aligned} \sum \mathbf{M} &= \mathbf{M}_A + \mathbf{r}_{AC} \times \mathbf{F} = 0 \\ &= M_{AX} \mathbf{i} + M_{AY} \mathbf{j} + M_{AZ} \mathbf{k} + \begin{vmatrix} \mathbf{i} & \mathbf{j} & \mathbf{k} \\ 15 & 10 & 0 \\ 360 & 240 & -720 \end{vmatrix} = 0 \\ &= M_{AX} \mathbf{i} + M_{AY} \mathbf{j} + M_{AZ} \mathbf{k} - 7200 \mathbf{i} + 10800 \mathbf{j} = 0 \end{aligned}$$

$$\underline{M_{AX} = 7200 \text{ N} \cdot \text{m}}, \underline{M_{AY} = -10800 \text{ N} \cdot \text{m}}, \text{ and } \underline{M_{AZ} = 0}$$

Note: For simpler problems, one can directly use three scalar moment equations, $\sum M_x = \sum M_y = \sum M_z = 0$

9

CONCEPT QUIZ

1. The rod AB is supported using two cables at B and a ball-and-socket joint at A. How many unknown support reactions exist in this problem?

- 1) 5 force and 1 moment reaction
- 2) 5 force reactions
- 3) 3 force and 3 moment reactions
- 4) 4 force and 2 moment reactions

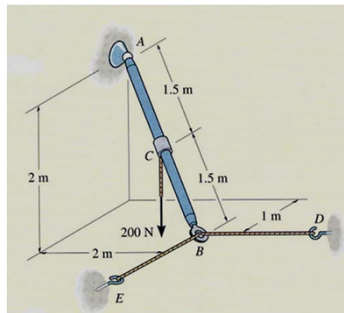

10

CONCEPT QUIZ (continued)

2. If an additional couple moment in the vertical direction is applied to rod AB at point C, then what will happen to the rod?
- A) The rod remains in equilibrium as the cables provide the necessary support reactions.
 - B) The rod remains in equilibrium as the ball-and-socket joint will provide the necessary resistive reactions.
 - C) The rod becomes unstable as the cables cannot support compressive forces.
 - D) The rod becomes unstable since a moment about AB cannot be restricted.

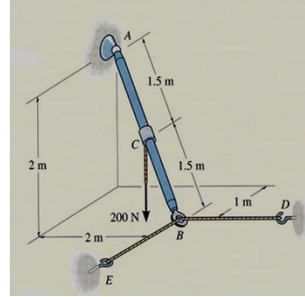

11

PROBLEM SOLVING

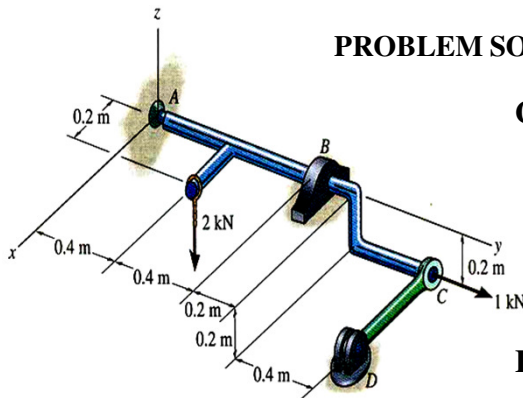

Given: A rod is supported by a ball-and-socket joint at A, a journal bearing at B and a short link at C. Assume the rod is properly aligned.

Find: The reactions at all the supports for the loading shown.

Plan:

- a) Draw a FBD of the rod.
- b) Apply scalar equations of equilibrium to solve for the unknowns.

12

PROBLEM SOLVING (continued)

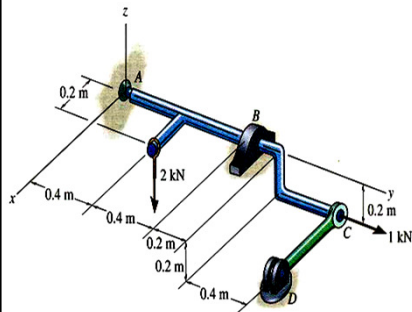

A FBD of the rod:

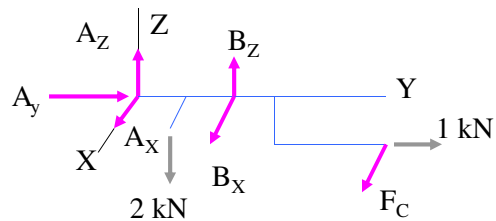

Applying scalar equations of equilibrium in appropriate order, we get

$$\sum M_Y = 2(0.2) - F_C(0.2) = 0; \quad F_C = 2 \text{ kN}$$

$$\sum F_Y = A_Y + 1 = 0; \quad A_Y = -1 \text{ kN}$$

$$\sum M_Z = -2(1.4) + B_X(0.8) = 0; \quad B_X = -3.5 \text{ kN}$$

13

PROBLEM SOLVING (continued)

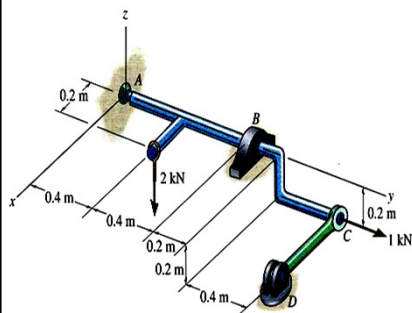

A FBD of the rod:

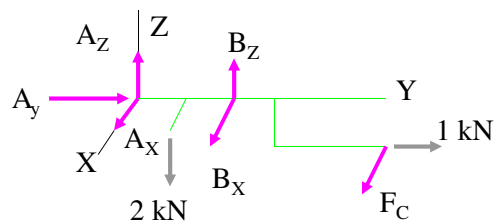

$$\sum F_X = A_X - 3.5 + 2 = 0; \quad A_X = 1.5 \text{ kN}$$

$$\sum M_X = -2(0.4) + B_Z(0.8) + 1(0.2) = 0; \quad B_Z = 0.75 \text{ kN}$$

$$\sum F_Z = A_Z + 0.75 - 2 = 0; \quad A_Z = 1.25 \text{ kN}$$

14

ATTENTION QUIZ

1. A plate is supported by a ball-and-socket joint at A, a roller joint at B, and a cable at C. How many unknown support reactions are there in this problem?

- A) 4 forces and 2 moments
- B) 6 forces
- C) 5 forces
- D) 4 forces and 1 moment

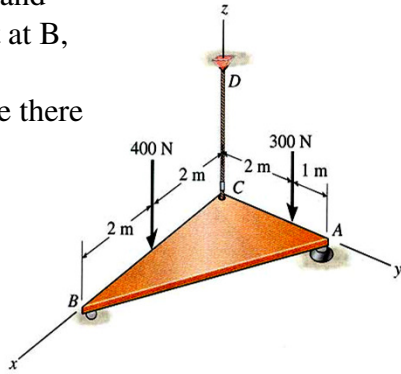

15

ATTENTION QUIZ

2. What will be the easiest way to determine the force reaction B_z ?

- A) Scalar equation $\sum F_z = 0$
- B) Vector equation $\sum \mathbf{M}_A = 0$
- C) Scalar equation $\sum M_z = 0$
- D) Scalar equation $\sum M_y = 0$

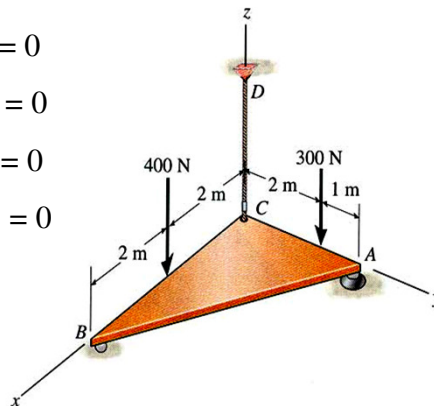

16

PROBLEM SOLVING

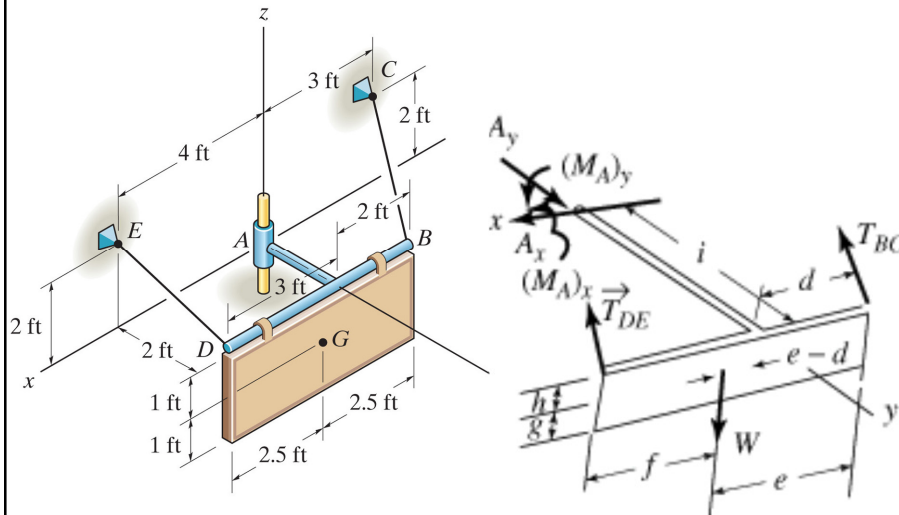

$M_{ax}, M_{ay}, T_{BC}, T_{DE}, A_x, A_y ?$

17