

---

## Laboratory 9 – Mathematics with Maple

### Assigned Week of December 1, 2014

### Due December 8, 2014 at 4:30 pm, See Section V

---

#### I – Introduction:

In this laboratory exercise, you will use Maplesoft’s Maple software to solve some simple engineering problems. Maple is an all-purpose computer programming software. It can be used to write sophisticated computer codes that include loops and logical statements like the ones used in the MATLAB exercises, however, Maple is most widely known because of its capabilities as a symbolic solver (i.e., computer algebra).

The purpose of this laboratory exercise is to introduce Maple software and to illustrate how Maple can be an effective tool for modelling engineering problems.

Instructions for getting started with Maple can be found in a number of places. Section 8, Chapters 33–37, in the textbook provides helpful advice on using Maple, particularly pertaining to the types of problems you will be solving in this exercise. Complete documentation for Maple can be found on Maplesoft’s website: [http://www.maplesoft.com/documentation\\_center/](http://www.maplesoft.com/documentation_center/), and many tutorials and guides can be found via a Google search. Finally, you can take advantage of the built-in help system in the Maple interface.

The first time you start the Maple application you will be prompted to use document mode or worksheet mode (subsequent uses of Maple may not prompt you). Whether you use one or the other is a matter of preference. You may find that the worksheet mode is the more straight-forward of the two and older documentation will often assume you are using it. On the other hand, the document mode allows for a more fluid integration of math and text. See this page for more details: <http://www.maplesoft.com/support/help/MapleSim/view.aspx?path=worksheet/help/documentsvsworksheets>.

Another choice that Maple gives you is to work in what it calls 1D or 2D math. In 1D math, you enter commands by typing in equations and function similar to how you use the Matlab command window. In 2D math, you enter equations by clicking at options from menus with the mouse and the input equations appear typeset. More information can be found here: <http://www.maplesoft.com/support/help/MapleSim/view.aspx?path=worksheet/documenting/2Dmath>  
All work for this exercise should be done using Maple 2D-Math, if possible.

#### II – Problem Statement:

**Part 1:** Use Maple to solve the circuit problem presented in Laboratory 7, except with the resistance  $R_1$  replaced with the symbol  $R$  (i.e.,  $R_1 := R$ ). All of the other parameters are equal to the numerical values they had in Laboratory 7. Kirchoff’s Voltage Law and Ohm’s Law are used to construct a system of equations, but now there is an extra unknown ( $R_1 = R$ ):

$$\begin{aligned}
 V_1 + R_2(i_1 - i_3) + R_1(i_1 - i_2) &= 0 \\
 V_2 + R_3(i_2 - i_3) + R_1(i_2 - i_1) &= 0 \\
 R_2(i_3 - i_1) + R_3(i_3 - i_2) + R_4 i_3 &= 0
 \end{aligned}
 \tag{1}$$

The values of the other parameters are:  $R_2 = 5 \Omega$ ,  $R_3 = 1 \Omega$ ,  $R_4 = 8 \Omega$ , and  $V_1 = 5.## \text{ V}$ , and  $V_2 = 3.## \text{ V}$ , where “##” are the last two digits of your student number. The circuit is shown in Figure 1.

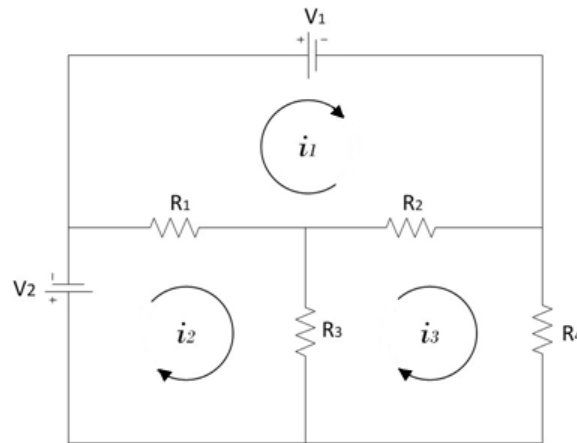

Figure 1: An electric circuit.

Perform the following steps with Maple using 2D-Math. All of your reported computer instructions shall be surrounded with words written in Text to describe what you are doing and why: marks will be lost if you do not include text with your computer instructions.

1. Use linear algebra to determine the *symbolic* formulas for the three currents in terms of the unknown resistance  $R$ . (*i.e.*, write equations (1) in matrix form: a matrix of resistance values multiplied by a vector of currents, the product of which is equal to a vector of voltages, and then solve for the current vector, as was done in Laboratory 7, and in Lecture 19.)
2. Plot the value of the current  $i_2$  as  $R$  ranges from 0 to 10  $\Omega$ . Note that when  $R = 6 \Omega$ , the value  $i_2$  on the plot should be the same as that found in Laboratory 7 with MATLAB. Use Maple to ‘evaluate at a point’ a value for  $i_2$  when  $R = 6 \Omega$ . Compare this value with the value determined in Laboratory 7 using MATLAB. Your plot should have labelled axes and your name and student number **must** appear in the title of the plot.
3. Use Maple’s Solve feature and the equations labelled (1) above to determine the *symbolic* formulas for the three currents in terms of the unknown resistance  $R$ . Compare the results with those obtained using linear algebra in step 1 above.

**Part 2:** In Lecture 7 we derived an equation for the temperature of a robot arm as a function of time that was based on Newton’s Law of Heating and Cooling. In the lecture, we used this equation to parameterize the temperature as the robot heated up to its steady-state operating temperature. In this laboratory exercise, you will use an equation of the same form to estimate the temperatures as the robot cools after being shut down. The problem is to estimate the time when the robot was shut down based on temperature measurements made at later times.

The temperature of the robot arm can be written as a function of time,  $f(t)$ :

$$f(t) = T_{room} + Ae^{kt} \quad (2)$$

where  $23.2^\circ\text{C}$  is the temperature of the room,  $T_{room}$ , that houses the robot. The room is very large compared with the robot, so the robot temperature does not affect the temperature of the room, which remains constant. The constants  $A$  and  $k$  are unknown and will be determined from measurements. When you entered the room at  $t = 0$  you noticed that the temperature of the robot was  $27.1^\circ\text{C}$ . After 5 minutes the robot cooled further and its temperature was  $25.7^\circ\text{C}$ . If the operating temperature of the robot was  $30.9^\circ\text{C}$  before it shut down, when was the robot shut down (*i.e.*, you will calculate the time-of-shutdown,  $tsd$ )?

Perform the following steps with Maple using 2D-Math. All of your reported computer instructions shall be surrounded with words written in Text to describe what you are doing and why: marks will be lost if you do not include text with your computer instructions.

1. Assign equation (2) as a function in Maple. (Hint: when writing the equation in Maple, for the exponential, use the  $e^a$  feature in the “Expression” Palette, or “exp(a)” . Also, you can use explicit multiplication by inserting a “\*” between two things you wish to multiply, such as  $a*b$ , or you can use implicit multiplication by just leaving a space between the terms you wish to multiply: see page 906 of the textbook.)
2. Input the measured temperatures as values for the function at different times to produce the set of equations to be solved.
3. Use Maple’s Solve feature to solve the equations for  $A$ ,  $k$  and  $tsd$ , where  $tsd$  is the time-of-shutdown.
4. Substitute the values for  $A$  and  $k$  into equation (1) and plot the temperature from  $t=-10$  min to  $t=30$  min. Your plot must include labelled axes and your name must appear in the title of the plot.
5. Use Maple to find the limit of equation (1) as time goes to “infinity”. What does this limit mean?
6. Explain the significance of the value for  $tsd$ .

**Part 3:** In the presence of an external driving voltage ( $V(t)$  in Volts), the charge  $q$  (in Coulombs) in a simple series *LRC* electrical circuit varies with time,  $t$ , according to the non-homogeneous second-order differential equation:

$$L \frac{d^2q}{dt^2} + R \frac{dq}{dt} + \frac{1}{C} q = V(t) \quad (3)$$

where the constants  $L$ ,  $R$ , and  $C$  are inductance (in henrys), resistance (in ohms), and capacitance (in farads) respectively, and time is in seconds: this equation is derived from Kirchhoff’s Law, *i.e.*, the voltage drops equal the voltage rises around any closed circuit loop. For our circuit, the inductance is 1 henrys, the resistance is 6 ohms, and the capacitance is  $1/8$  farads. The circuit is shown in Figure 2.

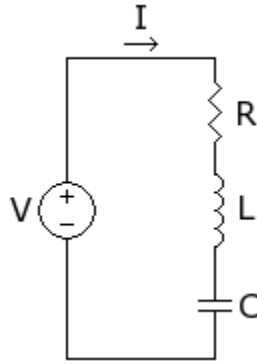

Figure 2: A RLC circuit.

When a circuit is switched from one state to another, for instance by a change in the applied voltage, there is a transitional period during which the current, and voltage, change from their former values to new ones. After this transitional period called the *transient*, the circuit is said to be in *steady state*. In this laboratory exercise, the external voltage driving the circuit is found to decay exponentially with time from an initial value of 2 V after the power supply is turned off according to

$$V(t) = 2e^{-2t} \quad (4)$$

When the power was turned off, the charge on the capacitor was zero and the current in the circuit was 1 A.

Perform the following steps with Maple using 2D-Math. All of your reported computer instructions shall be surrounded with words written in Text to describe what you are doing and why: marks will be lost if you do not include text with your computer instructions.

1. Use Maple's 'differential equation solver' to solve equation 3 for the charge transient given the initial values:  $q(0)=0$  and  $i(0) = dq(0) / dt = 1$  A . Verify that the charge transient changes according to the equation:

$$q(t) = t e^{-2t} \quad (5)$$

You will learn how to compute the general solution for this type of differential equation in MATH 1005.

2. Plot the charge transient (equation (5)) and the current transient from  $t=0$  to 3 sec. You must include labelled axes and your name **must** appear in the title of the plot.
3. Determine the value of the maximum charge on the capacitor and the minimum transient current and the times at which they occur.

### III — Steps and Calculations:

Using Maple and its functions, perform all the necessary steps to obtain the answers to each of the questions and problems presented above. All calculations are to be done using 2D-Math. All plots must include labelled axes, and your name must appear in the title of each plot: no name = no marks. Your computer instructions shall be surrounded by Text that describes the steps you take to generate your solutions: do not simply give series of instructions without explanations: no explanations = zero marks.

## IV — Report Requirements and Deliverables:

- Using the guidelines presented in Laboratory 1, produce a formal laboratory report that summarizes your findings.
- This laboratory exercise is designed to familiarize you with Maple applications. You should be able to identify a central focus (central objective) to use as guidance in writing your report.
- Appendices should be added for the Maple computer-code instructions and output. These will include detailed descriptions of what is being done and why.
- State briefly the results to all of the problems posed. Discuss the significance of the results in each case.
- In general terms, discuss the usefulness of Maple as an engineering software tool.

<i>Deliverables Summary</i>	
<i>The lab assignment includes the following:</i>	
1.	Title page
2.	One-page report
3.	Appendix with Maple worksheet solution for Part 1.
4.	Appendix with Maple worksheet solution for Part 2.
5.	Appendix with Maple worksheet solution for Part 3.
<b>IMPORTANT NOTE:</b> Make sure all of your plots are properly labelled.	

**Upload your completed lab assignment to cuLearn with file name: "Lab Section\_Student number.docx" (e.g. "C3\_100812345.docx" is for C3 Lab section)**

## V — Submission and Timing:

Your report is to be uploaded to cuLearn no later than 16:30 on December 8, 2014. **LATE SUBMISSIONS WILL NOT BE ACCEPTED.**

## VI — Marking:

Laboratory submissions will be marked on a 10-point scale: 9-10 (excellent); 7-8 (good); 5-6 (marginal); less than 5 (poor). **Be sure that you are familiar with the University's policy on plagiarism and academic integrity. Your instructors are obligated to report all suspected violations to the Associate Dean's office for investigation (see also chapter 14 at <http://calendar.carleton.ca/undergrad/regulations/academicregulationsoftheuniversity/>).**