

Chapter 5

MASS AND ENERGY ANALYSIS OF CONTROL VOLUMES

In Chap. 4, we applied the general energy balance relation expressed as $E_{\text{in}} - E_{\text{out}} = \Delta E_{\text{system}}$ to closed systems. In this chapter, we extend the energy analysis to systems that involve mass flow across their boundaries i.e., control volumes, with particular emphasis to steady-flow systems.

We start this chapter with the development of the general *conservation of mass* relation for control volumes, and we continue with a discussion of flow work and the energy of fluid streams. We then apply the energy balance to systems that involve *steady-flow processes* and analyze the common steady-flow devices such as nozzles, diffusers, compressors, turbines, throttling devices, mixing chambers, and heat exchangers. Finally, we apply the energy balance to general *unsteady-flow processes* such as the charging and discharging of vessels.

Objectives

The objectives of Chapter 5 are to:

- Develop the conservation of mass principle.
- Apply the conservation of mass principle to various systems including steady- and unsteady-flow control volumes.
- Apply the first law of thermodynamics as the statement of the conservation of energy principle to control volumes.
- Identify the energy carried by a fluid stream crossing a control surface as the sum of internal energy, flow work, kinetic energy, and potential energy of the fluid and to relate the combination of the internal energy and the flow work to the property enthalpy.
- Solve energy balance problems for common steady-flow devices such as nozzles, compressors, turbines, throttling valves, mixers, heaters, and heat exchangers.
- Apply the energy balance to general unsteady-flow processes with particular emphasis on the uniform-flow process as the model for commonly encountered charging and discharging processes.

**INTERACTIVE
TUTORIAL**

SEE TUTORIAL CH. 5, SEC. 1 ON THE DVD.

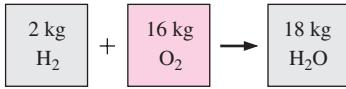
FIGURE 5-1

Mass is conserved even during chemical reactions.

5-1 ■ CONSERVATION OF MASS

Conservation of mass is one of the most fundamental principles in nature. We are all familiar with this principle, and it is not difficult to understand. As the saying goes, You cannot have your cake and eat it too! A person does not have to be a scientist to figure out how much vinegar-and-oil dressing is obtained by mixing 100 g of oil with 25 g of vinegar. Even chemical equations are balanced on the basis of the conservation of mass principle. When 16 kg of oxygen reacts with 2 kg of hydrogen, 18 kg of water is formed (Fig. 5-1). In an electrolysis process, the water separates back to 2 kg of hydrogen and 16 kg of oxygen.

Mass, like energy, is a conserved property, and it cannot be created or destroyed during a process. However, mass m and energy E can be converted to each other according to the well-known formula proposed by Albert Einstein (1879–1955):

$$E = mc^2 \quad (5-1)$$

where c is the speed of light in a vacuum, which is $c = 2.9979 \times 10^8$ m/s. This equation suggests that the mass of a system changes when its energy changes. However, for all energy interactions encountered in practice, with the exception of nuclear reactions, the change in mass is extremely small and cannot be detected by even the most sensitive devices. For example, when 1 kg of water is formed from oxygen and hydrogen, the amount of energy released is 15,879 kJ, which corresponds to a mass of 1.76×10^{-10} kg. A mass of this magnitude is beyond the accuracy required by practically all engineering calculations and thus can be disregarded.

For *closed systems*, the conservation of mass principle is implicitly used by requiring that the mass of the system remain constant during a process. For *control volumes*, however, mass can cross the boundaries, and so we must keep track of the amount of mass entering and leaving the control volume.

Mass and Volume Flow Rates

The amount of mass flowing through a cross section per unit time is called the **mass flow rate** and is denoted by \dot{m} . The dot over a symbol is used to indicate *time rate of change*, as explained in Chap. 2.

A fluid usually flows into or out of a control volume through pipes or ducts. The differential mass flow rate of fluid flowing across a small area element dA_c on a flow cross section is proportional to dA_c itself, the fluid density ρ , and the component of the flow velocity normal to dA_c , which we denote as V_n , and is expressed as (Fig. 5-2)

$$\delta \dot{m} = \rho V_n dA_c \quad (5-2)$$

Note that both δ and d are used to indicate differential quantities, but δ is typically used for quantities (such as heat, work, and mass transfer) that are *path functions* and have *inexact differentials*, while d is used for quantities (such as properties) that are *point functions* and have *exact differentials*. For flow through an annulus of inner radius r_1 and outer radius r_2 , for example,

$\int_1^2 dA_c = A_{c2} - A_{c1} = \pi(r_2^2 - r_1^2)$ but $\int_1^2 \delta \dot{m} = \dot{m}_{\text{total}}$ (total mass flow rate through the annulus), not $\dot{m}_2 - \dot{m}_1$. For specified values of r_1 and r_2 , the value of the integral of dA_c is fixed (thus the names point function and exact

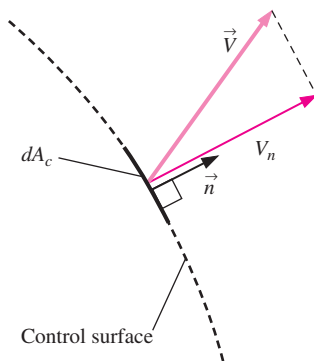
FIGURE 5-2

The normal velocity V_n for a surface is the component of velocity perpendicular to the surface.

differential), but this is not the case for the integral of $\delta\dot{m}$ (thus the names path function and inexact differential).

The mass flow rate through the entire cross-sectional area of a pipe or duct is obtained by integration:

$$\dot{m} = \int_{A_c} \delta\dot{m} = \int_{A_c} \rho V_n dA_c \quad (\text{kg/s}) \quad (5-3)$$

While Eq. 5-3 is always valid (in fact it is *exact*), it is not always practical for engineering analyses because of the integral. We would like instead to express mass flow rate in terms of average values over a cross section of the pipe. In a general compressible flow, both ρ and V_n vary across the pipe. In many practical applications, however, the density is essentially uniform over the pipe cross section, and we can take ρ outside the integral of Eq. 5-3. Velocity, however, is *never* uniform over a cross section of a pipe because of the fluid sticking to the surface and thus having zero velocity at the wall (the no-slip condition). Rather, the velocity varies from zero at the walls to some maximum value at or near the centerline of the pipe. We define the **average velocity** V_{avg} as the average value of V_n across the entire cross section (Fig. 5-3),

$$\text{Average velocity:} \quad V_{\text{avg}} = \frac{1}{A_c} \int_{A_c} V_n dA_c \quad (5-4)$$

where A_c is the area of the cross section normal to the flow direction. Note that if the velocity were V_{avg} all through the cross section, the mass flow rate would be identical to that obtained by integrating the actual velocity profile. Thus for incompressible flow or even for compressible flow where ρ is uniform across A_c , Eq. 5-3 becomes

$$\dot{m} = \rho V_{\text{avg}} A_c \quad (\text{kg/s}) \quad (5-5)$$

For compressible flow, we can think of ρ as the bulk average density over the cross section, and then Eq. 5-5 can still be used as a reasonable approximation.

For simplicity, we drop the subscript on the average velocity. Unless otherwise stated, V denotes the average velocity in the flow direction. Also, A_c denotes the cross-sectional area normal to the flow direction.

The volume of the fluid flowing through a cross section per unit time is called the **volume flow rate** \dot{V} (Fig. 5-4) and is given by

$$\dot{V} = \int_{A_c} V_n dA_c = V_{\text{avg}} A_c = VA_c \quad (\text{m}^3/\text{s}) \quad (5-6)$$

An early form of Eq. 5-6 was published in 1628 by the Italian monk Benedetto Castelli (circa 1577–1644). Note that most fluid mechanics textbooks use Q instead of \dot{V} for volume flow rate. We use \dot{V} to avoid confusion with heat transfer.

The mass and volume flow rates are related by

$$\dot{m} = \rho \dot{V} = \frac{\dot{V}}{\nu} \quad (5-7)$$

where ν is the specific volume. This relation is analogous to $m = \rho V = V/\nu$, which is the relation between the mass and the volume of a fluid in a container.

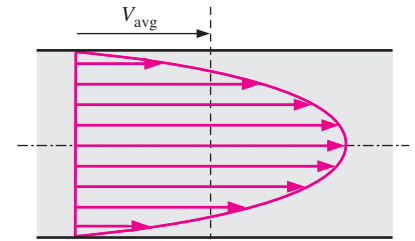

FIGURE 5-3

The average velocity V_{avg} is defined as the average speed through a cross section.

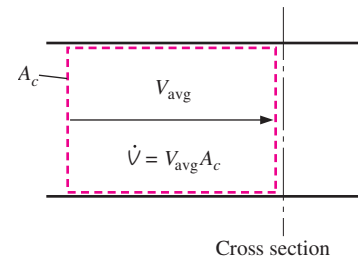
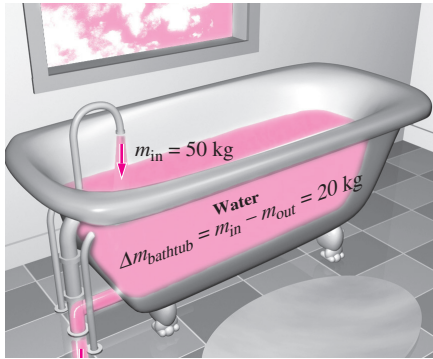

FIGURE 5-4

The volume flow rate is the volume of fluid flowing through a cross section per unit time.

FIGURE 5-5

Conservation of mass principle for an ordinary bathtub.

Conservation of Mass Principle

The **conservation of mass principle** for a control volume can be expressed as: *The net mass transfer to or from a control volume during a time interval Δt is equal to the net change (increase or decrease) in the total mass within the control volume during Δt .* That is,

$$\left(\begin{array}{c} \text{Total mass entering} \\ \text{the CV during } \Delta t \end{array} \right) - \left(\begin{array}{c} \text{Total mass leaving} \\ \text{the CV during } \Delta t \end{array} \right) = \left(\begin{array}{c} \text{Net change in mass} \\ \text{within the CV during } \Delta t \end{array} \right)$$

or

$$m_{\text{in}} - m_{\text{out}} = \Delta m_{\text{CV}} \quad (\text{kg}) \quad (5-8)$$

where $\Delta m_{\text{CV}} = m_{\text{final}} - m_{\text{initial}}$ is the change in the mass of the control volume during the process (Fig. 5-5). It can also be expressed in *rate form* as

$$\dot{m}_{\text{in}} - \dot{m}_{\text{out}} = dm_{\text{CV}}/dt \quad (\text{kg/s}) \quad (5-9)$$

where \dot{m}_{in} and \dot{m}_{out} are the total rates of mass flow into and out of the control volume, and dm_{CV}/dt is the time rate of change of mass within the control volume boundaries. Equations 5-8 and 5-9 are often referred to as the **mass balance** and are applicable to any control volume undergoing any kind of process.

Consider a control volume of arbitrary shape, as shown in Fig. 5-6. The mass of a differential volume dV within the control volume is $dm = \rho dV$. The total mass within the control volume at any instant in time t is determined by integration to be

$$\text{Total mass within the CV:} \quad m_{\text{CV}} = \int_{\text{CV}} \rho dV \quad (5-10)$$

Then the time rate of change of the amount of mass within the control volume can be expressed as

$$\text{Rate of change of mass within the CV:} \quad \frac{dm_{\text{CV}}}{dt} = \frac{d}{dt} \int_{\text{CV}} \rho dV \quad (5-11)$$

For the special case of no mass crossing the control surface (i.e., the control volume resembles a closed system), the conservation of mass principle reduces to that of a system that can be expressed as $dm_{\text{CV}}/dt = 0$. This relation is valid whether the control volume is fixed, moving, or deforming.

Now consider mass flow into or out of the control volume through a differential area dA on the control surface of a fixed control volume. Let \vec{n} be the outward unit vector of dA normal to dA and \vec{V} be the flow velocity at dA relative to a fixed coordinate system, as shown in Fig. 5-6. In general, the velocity may cross dA at an angle θ off the normal of dA , and the mass flow rate is proportional to the normal component of velocity $\vec{V}_n = \vec{V} \cos \theta$ ranging from a maximum outflow of \vec{V} for $\theta = 0$ (flow is normal to dA) to a minimum of zero for $\theta = 90^\circ$ (flow is tangent to dA) to a maximum inflow of \vec{V} for $\theta = 180^\circ$ (flow is normal to dA but in the opposite direction). Making use of the concept of dot product of two vectors, the magnitude of the normal component of velocity can be expressed as

$$\text{Normal component of velocity:} \quad V_n = V \cos \theta = \vec{V} \cdot \vec{n} \quad (5-12)$$

The mass flow rate through dA is proportional to the fluid density ρ , normal velocity V_n , and the flow area dA , and can be expressed as

$$\text{Differential mass flow rate:} \quad \delta \dot{m} = \rho V_n dA = \rho (V \cos \theta) dA = \rho (\vec{V} \cdot \vec{n}) dA \quad (5-13)$$

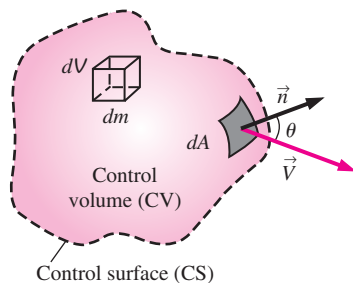
FIGURE 5-6

The differential control volume dV and the differential control surface dA used in the derivation of the conservation of mass relation.

The net flow rate into or out of the control volume through the entire control surface is obtained by integrating $\delta\dot{m}$ over the entire control surface,

$$\text{Net mass flow rate: } \dot{m}_{\text{net}} = \int_{\text{CS}} \delta\dot{m} = \int_{\text{CS}} \rho V_n dA = \int_{\text{CS}} \rho(\vec{V} \cdot \vec{n}) dA \quad (5-14)$$

Note that $\vec{V} \cdot \vec{n} = V \cos \theta$ is positive for $\theta < 90^\circ$ (outflow) and negative for $\theta > 90^\circ$ (inflow). Therefore, the direction of flow is automatically accounted for, and the surface integral in Eq. 5–14 directly gives the *net* mass flow rate. A positive value for \dot{m}_{net} indicates net outflow, and a negative value indicates a net inflow of mass.

Rearranging Eq. 5–9 as $dm_{\text{CV}}/dt + \dot{m}_{\text{out}} - \dot{m}_{\text{in}} = 0$, the conservation of mass relation for a fixed control volume can then be expressed as

$$\text{General conservation of mass: } \frac{d}{dt} \int_{\text{CV}} \rho dV + \int_{\text{CS}} \rho(\vec{V} \cdot \vec{n}) dA = 0 \quad (5-15)$$

It states that *the time rate of change of mass within the control volume plus the net mass flow rate through the control surface is equal to zero.*

Splitting the surface integral in Eq. 5–15 into two parts—one for the outgoing flow streams (positive) and one for the incoming streams (negative)—the general conservation of mass relation can also be expressed as

$$\frac{d}{dt} \int_{\text{CV}} \rho dV + \sum_{\text{out}} \int_A \rho V_n dA - \sum_{\text{in}} \int_A \rho V_n dA = 0 \quad (5-16)$$

where A represents the area for an inlet or outlet, and the summation signs are used to emphasize that *all* the inlets and outlets are to be considered. Using the definition of mass flow rate, Eq. 5–16 can also be expressed as

$$\frac{d}{dt} \int_{\text{CV}} \rho dV = \sum_{\text{in}} \dot{m} - \sum_{\text{out}} \dot{m} \quad \text{or} \quad \frac{dm_{\text{CV}}}{dt} = \sum_{\text{in}} \dot{m} - \sum_{\text{out}} \dot{m} \quad (5-17)$$

Equations 5–15 and 5–16 are also valid for moving or deforming control volumes provided that the *absolute velocity* \vec{V} is replaced by the *relative velocity* \vec{V}_r , which is the fluid velocity relative to the control surface.

Mass Balance for Steady-Flow Processes

During a steady-flow process, the total amount of mass contained within a control volume does not change with time ($m_{\text{CV}} = \text{constant}$). Then the conservation of mass principle requires that the total amount of mass entering a control volume equal the total amount of mass leaving it. For a garden hose nozzle in steady operation, for example, the amount of water entering the nozzle per unit time is equal to the amount of water leaving it per unit time.

When dealing with steady-flow processes, we are not interested in the amount of mass that flows in or out of a device over time; instead, we are interested in the amount of mass flowing per unit time, that is, *the mass flow rate* \dot{m} . *The conservation of mass principle* for a general steady-flow system with multiple inlets and outlets can be expressed in rate form as (Fig. 5–7)

$$\text{Steady flow: } \sum_{\text{in}} \dot{m} = \sum_{\text{out}} \dot{m} \quad (\text{kg/s}) \quad (5-18)$$

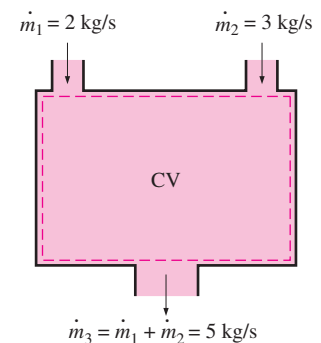

FIGURE 5–7 Conservation of mass principle for a two-inlet–one-outlet steady-flow system.

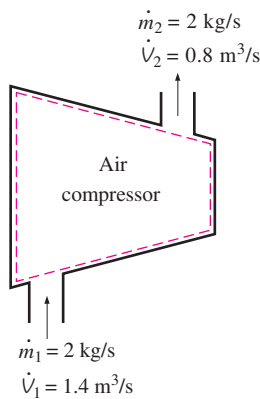

FIGURE 5-8

During a steady-flow process, volume flow rates are not necessarily conserved although mass flow rates are.

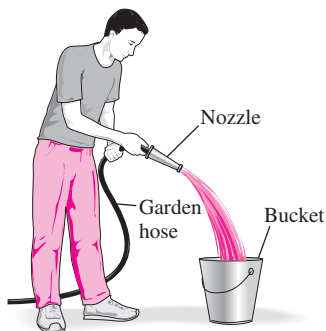

FIGURE 5-9

Schematic for Example 5-1.

It states that *the total rate of mass entering a control volume is equal to the total rate of mass leaving it.*

Many engineering devices such as nozzles, diffusers, turbines, compressors, and pumps involve a single stream (only one inlet and one outlet). For these cases, we denote the inlet state by the subscript 1 and the outlet state by the subscript 2, and drop the summation signs. Then Eq. 5-18 reduces, for *single-stream steady-flow systems*, to

$$\text{Steady flow (single stream): } \dot{m}_1 = \dot{m}_2 \rightarrow \rho_1 V_1 A_1 = \rho_2 V_2 A_2 \quad (5-19)$$

Special Case: Incompressible Flow

The conservation of mass relations can be simplified even further when the fluid is incompressible, which is usually the case for liquids. Canceling the density from both sides of the general steady-flow relation gives

$$\text{Steady, incompressible flow: } \sum_{\text{in}} \dot{V} = \sum_{\text{out}} \dot{V} \quad (\text{m}^3/\text{s}) \quad (5-20)$$

For single-stream steady-flow systems it becomes

$$\text{Steady, incompressible flow (single stream): } \dot{V}_1 = \dot{V}_2 \rightarrow V_1 A_1 = V_2 A_2 \quad (5-21)$$

It should always be kept in mind that there is no such thing as a “conservation of volume” principle. Therefore, the volume flow rates into and out of a steady-flow device may be different. The volume flow rate at the outlet of an air compressor is much less than that at the inlet even though the mass flow rate of air through the compressor is constant (Fig. 5-8). This is due to the higher density of air at the compressor exit. For steady flow of liquids, however, the volume flow rates, as well as the mass flow rates, remain constant since liquids are essentially incompressible (constant-density) substances. Water flow through the nozzle of a garden hose is an example of the latter case.

The conservation of mass principle is based on experimental observations and requires every bit of mass to be accounted for during a process. If you can balance your checkbook (by keeping track of deposits and withdrawals, or by simply observing the “conservation of money” principle), you should have no difficulty applying the conservation of mass principle to engineering systems.

EXAMPLE 5-1 Water Flow through a Garden Hose Nozzle

A garden hose attached with a nozzle is used to fill a 10-gal bucket. The inner diameter of the hose is 2 cm, and it reduces to 0.8 cm at the nozzle exit (Fig. 5-9). If it takes 50 s to fill the bucket with water, determine (a) the volume and mass flow rates of water through the hose, and (b) the average velocity of water at the nozzle exit.

Solution A garden hose is used to fill a water bucket. The volume and mass flow rates of water and the exit velocity are to be determined.

Assumptions 1 Water is an incompressible substance. 2 Flow through the hose is steady. 3 There is no waste of water by splashing.

Properties We take the density of water to be $1000 \text{ kg/m}^3 = 1 \text{ kg/L}$.

Analysis (a) Noting that 10 gal of water are discharged in 50 s, the volume and mass flow rates of water are

$$\dot{V} = \frac{V}{\Delta t} = \frac{10 \text{ gal}}{50 \text{ s}} \left(\frac{3.7854 \text{ L}}{1 \text{ gal}} \right) = \mathbf{0.757 \text{ L/s}}$$

$$\dot{m} = \rho \dot{V} = (1 \text{ kg/L})(0.757 \text{ L/s}) = \mathbf{0.757 \text{ kg/s}}$$

(b) The cross-sectional area of the nozzle exit is

$$A_e = \pi r_e^2 = \pi (0.4 \text{ cm})^2 = 0.5027 \text{ cm}^2 = 0.5027 \times 10^{-4} \text{ m}^2$$

The volume flow rate through the hose and the nozzle is constant. Then the average velocity of water at the nozzle exit becomes

$$V_e = \frac{\dot{V}}{A_e} = \frac{0.757 \text{ L/s}}{0.5027 \times 10^{-4} \text{ m}^2} \left(\frac{1 \text{ m}^3}{1000 \text{ L}} \right) = \mathbf{15.1 \text{ m/s}}$$

Discussion It can be shown that the average velocity in the hose is 2.4 m/s. Therefore, the nozzle increases the water velocity by over six times.

EXAMPLE 5–2 Discharge of Water from a Tank

A 4-ft-high, 3-ft-diameter cylindrical water tank whose top is open to the atmosphere is initially filled with water. Now the discharge plug near the bottom of the tank is pulled out, and a water jet whose diameter is 0.5 in streams out (Fig. 5–10). The average velocity of the jet is given by $V = \sqrt{2gh}$, where h is the height of water in the tank measured from the center of the hole (a variable) and g is the gravitational acceleration. Determine how long it will take for the water level in the tank to drop to 2 ft from the bottom.

Solution The plug near the bottom of a water tank is pulled out. The time it takes for half of the water in the tank to empty is to be determined.

Assumptions **1** Water is an incompressible substance. **2** The distance between the bottom of the tank and the center of the hole is negligible compared to the total water height. **3** The gravitational acceleration is 32.2 ft/s^2 .

Analysis We take the volume occupied by water as the control volume. The size of the control volume decreases in this case as the water level drops, and thus this is a variable control volume. (We could also treat this as a fixed control volume that consists of the interior volume of the tank by disregarding the air that replaces the space vacated by the water.) This is obviously an unsteady-flow problem since the properties (such as the amount of mass) within the control volume change with time.

The conservation of mass relation for a control volume undergoing any process is given in the rate form as

$$\dot{m}_{\text{in}} - \dot{m}_{\text{out}} = \frac{dm_{\text{CV}}}{dt} \quad (1)$$

During this process no mass enters the control volume ($\dot{m}_{\text{in}} = 0$), and the mass flow rate of discharged water can be expressed as

$$\dot{m}_{\text{out}} = (\rho VA)_{\text{out}} = \rho \sqrt{2gh} A_{\text{jet}} \quad (2)$$

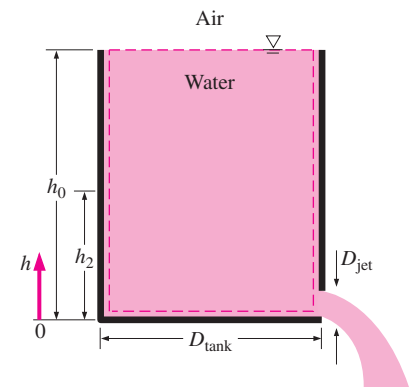

FIGURE 5–10
Schematic for Example 5–2.

where $A_{\text{jet}} = \pi D_{\text{jet}}^2/4$ is the cross-sectional area of the jet, which is constant. Noting that the density of water is constant, the mass of water in the tank at any time is

$$m_{\text{CV}} = \rho V = \rho A_{\text{tank}} h \quad (3)$$

where $A_{\text{tank}} = \pi D_{\text{tank}}^2/4$ is the base area of the cylindrical tank. Substituting Eqs. 2 and 3 into the mass balance relation (Eq. 1) gives

$$-\rho \sqrt{2gh} A_{\text{jet}} = \frac{d(\rho A_{\text{tank}} h)}{dt} \rightarrow -\rho \sqrt{2gh} (\pi D_{\text{jet}}^2/4) = \frac{\rho (\pi D_{\text{tank}}^2/4) dh}{dt}$$

Canceling the densities and other common terms and separating the variables give

$$dt = \frac{D_{\text{tank}}^2}{D_{\text{jet}}^2} \frac{dh}{\sqrt{2gh}}$$

Integrating from $t = 0$ at which $h = h_0$ to $t = t$ at which $h = h_2$ gives

$$\int_0^t dt = - \frac{D_{\text{tank}}^2}{D_{\text{jet}}^2 \sqrt{2g}} \int_{h_0}^{h_2} \frac{dh}{\sqrt{h}} \rightarrow t = \frac{\sqrt{h_0} - \sqrt{h_2}}{\sqrt{g/2}} \left(\frac{D_{\text{tank}}}{D_{\text{jet}}} \right)^2$$

Substituting, the time of discharge is

$$t = \frac{\sqrt{4 \text{ ft}} - \sqrt{2 \text{ ft}}}{\sqrt{32.2/2 \text{ ft/s}^2}} \left(\frac{3 \times 12 \text{ in}}{0.5 \text{ in}} \right)^2 = 757 \text{ s} = \mathbf{12.6 \text{ min}}$$

Therefore, half of the tank is emptied in 12.6 min after the discharge hole is unplugged.

Discussion Using the same relation with $h_2 = 0$ gives $t = 43.1$ min for the discharge of the entire amount of water in the tank. Therefore, emptying the bottom half of the tank takes much longer than emptying the top half. This is due to the decrease in the average discharge velocity of water with decreasing h .



INTERACTIVE
TUTORIAL

SEE TUTORIAL CH. 5, SEC. 2 ON THE DVD.

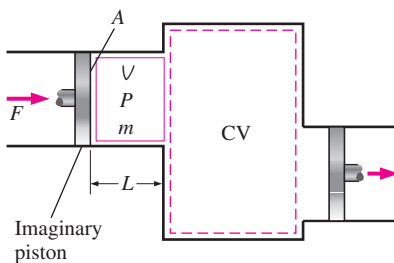

FIGURE 5–11

Schematic for flow work.

5–2 ■ FLOW WORK AND THE ENERGY OF A FLOWING FLUID

Unlike closed systems, control volumes involve mass flow across their boundaries, and some work is required to push the mass into or out of the control volume. This work is known as the **flow work**, or **flow energy**, and is necessary for maintaining a continuous flow through a control volume.

To obtain a relation for flow work, consider a fluid element of volume V as shown in Fig. 5–11. The fluid immediately upstream forces this fluid element to enter the control volume; thus, it can be regarded as an imaginary piston. The fluid element can be chosen to be sufficiently small so that it has uniform properties throughout.

If the fluid pressure is P and the cross-sectional area of the fluid element is A (Fig. 5–12), the force applied on the fluid element by the imaginary piston is

$$F = PA \quad (5-22)$$

To push the entire fluid element into the control volume, this force must act through a distance L . Thus, the work done in pushing the fluid element across the boundary (i.e., the flow work) is

$$W_{\text{flow}} = FL = PAL = P\mathcal{V} \quad (\text{kJ}) \quad (5-23)$$

The flow work per unit mass is obtained by dividing both sides of this equation by the mass of the fluid element:

$$w_{\text{flow}} = P\mathcal{v} \quad (\text{kJ/kg}) \quad (5-24)$$

The flow work relation is the same whether the fluid is pushed into or out of the control volume (Fig. 5–13).

It is interesting that unlike other work quantities, flow work is expressed in terms of properties. In fact, it is the product of two properties of the fluid. For that reason, some people view it as a *combination property* (like enthalpy) and refer to it as *flow energy*, *convected energy*, or *transport energy* instead of flow work. Others, however, argue rightfully that the product $P\mathcal{V}$ represents energy for flowing fluids only and does not represent any form of energy for nonflow (closed) systems. Therefore, it should be treated as work. This controversy is not likely to end, but it is comforting to know that both arguments yield the same result for the energy balance equation. In the discussions that follow, we consider the flow energy to be part of the energy of a flowing fluid, since this greatly simplifies the energy analysis of control volumes.

Total Energy of a Flowing Fluid

As we discussed in Chap. 2, the total energy of a simple compressible system consists of three parts: internal, kinetic, and potential energies (Fig. 5–14). On a unit-mass basis, it is expressed as

$$e = u + ke + pe = u + \frac{V^2}{2} + gz \quad (\text{kJ/kg}) \quad (5-25)$$

where V is the velocity and z is the elevation of the system relative to some external reference point.

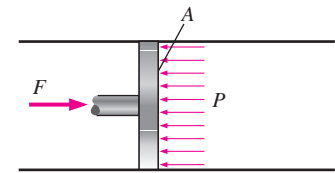

FIGURE 5–12

In the absence of acceleration, the force applied on a fluid by a piston is equal to the force applied on the piston by the fluid.

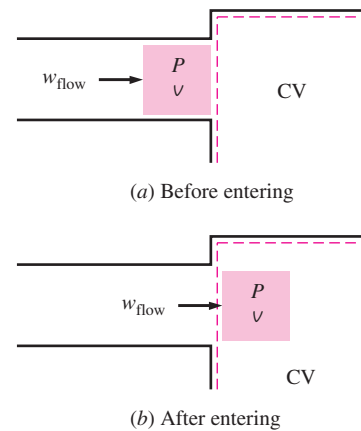

FIGURE 5–13

Flow work is the energy needed to push a fluid into or out of a control volume, and it is equal to $P\mathcal{V}$.

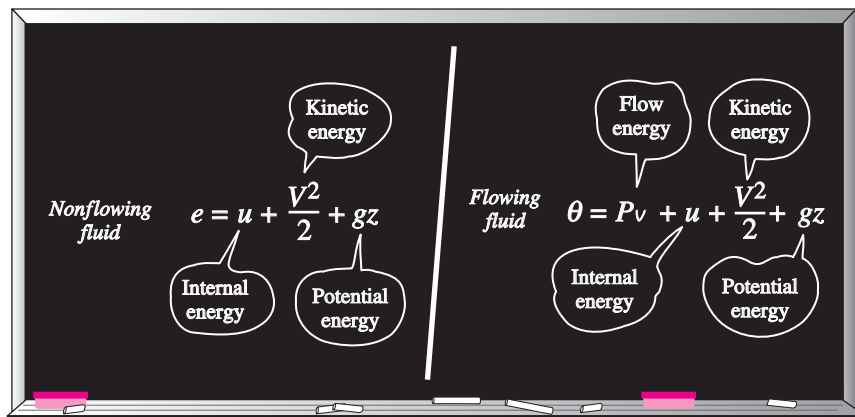

FIGURE 5–14

The total energy consists of three parts for a nonflowing fluid and four parts for a flowing fluid.

The fluid entering or leaving a control volume possesses an additional form of energy—the *flow energy* Pv , as already discussed. Then the total energy of a **flowing fluid** on a unit-mass basis (denoted by θ) becomes

$$\theta = Pv + e = Pv + (u + ke + pe) \quad (5-26)$$

But the combination $Pv + u$ has been previously defined as the enthalpy h . So the relation in Eq. 5-26 reduces to

$$\theta = h + ke + pe = h + \frac{V^2}{2} + gz \quad (\text{kJ/kg}) \quad (5-27)$$

By using the enthalpy instead of the internal energy to represent the energy of a flowing fluid, one does not need to be concerned about the flow work. The energy associated with pushing the fluid into or out of the control volume is automatically taken care of by enthalpy. In fact, this is the main reason for defining the property enthalpy. From now on, the energy of a fluid stream flowing into or out of a control volume is represented by Eq. 5-27, and no reference will be made to flow work or flow energy.

Energy Transport by Mass

Noting that θ is total energy per unit mass, the total energy of a flowing fluid of mass m is simply $m\theta$, provided that the properties of the mass m are uniform. Also, when a fluid stream with uniform properties is flowing at a mass flow rate of \dot{m} , the rate of energy flow with that stream is $\dot{m}\theta$ (Fig. 5-15). That is,

$$\text{Amount of energy transport: } E_{\text{mass}} = m\theta = m\left(h + \frac{V^2}{2} + gz\right) \quad (\text{kJ}) \quad (5-28)$$

$$\text{Rate of energy transport: } \dot{E}_{\text{mass}} = \dot{m}\theta = \dot{m}\left(h + \frac{V^2}{2} + gz\right) \quad (\text{kW}) \quad (5-29)$$

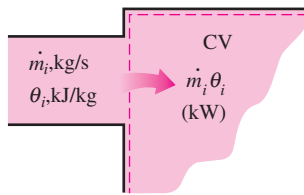

FIGURE 5-15

The product $\dot{m}_i\theta_i$ is the energy transported into control volume by mass per unit time.

When the kinetic and potential energies of a fluid stream are negligible, as is often the case, these relations simplify to $E_{\text{mass}} = mh$ and $\dot{E}_{\text{mass}} = \dot{m}h$.

In general, the total energy transported by mass into or out of the control volume is not easy to determine since the properties of the mass at each inlet or exit may be changing with time as well as over the cross section. Thus, the only way to determine the energy transport through an opening as a result of mass flow is to consider sufficiently small differential masses δm that have uniform properties and to add their total energies during flow.

Again noting that θ is total energy per unit mass, the total energy of a flowing fluid of mass δm is $\theta \delta m$. Then the total energy transported by mass through an inlet or exit ($m_i\theta_i$ and $m_e\theta_e$) is obtained by integration. At an inlet, for example, it becomes

$$E_{\text{in,mass}} = \int_{m_i} \theta_i \delta m_i = \int_{m_i} \left(h_i + \frac{V_i^2}{2} + gz_i \right) \delta m_i \quad (5-30)$$

Most flows encountered in practice can be approximated as being steady and one-dimensional, and thus the simple relations in Eqs. 5-28 and 5-29 can be used to represent the energy transported by a fluid stream.

EXAMPLE 5–3 Energy Transport by Mass

Steam is leaving a 4-L pressure cooker whose operating pressure is 150 kPa (Fig. 5–16). It is observed that the amount of liquid in the cooker has decreased by 0.6 L in 40 min after the steady operating conditions are established, and the cross-sectional area of the exit opening is 8 mm². Determine (a) the mass flow rate of the steam and the exit velocity, (b) the total and flow energies of the steam per unit mass, and (c) the rate at which energy leaves the cooker by steam.

Solution Steam leaves a pressure cooker at a specified pressure. The velocity, flow rate, the total and flow energies, and the rate of energy transfer by mass are to be determined.

Assumptions **1** The flow is steady, and the initial start-up period is disregarded. **2** The kinetic and potential energies are negligible, and thus they are not considered. **3** Saturation conditions exist within the cooker at all times so that steam leaves the cooker as a saturated vapor at the cooker pressure.

Properties The properties of saturated liquid water and water vapor at 150 kPa are $v_f = 0.001053 \text{ m}^3/\text{kg}$, $v_g = 1.1594 \text{ m}^3/\text{kg}$, $u_g = 2519.2 \text{ kJ/kg}$, and $h_g = 2693.1 \text{ kJ/kg}$ (Table A–5).

Analysis (a) Saturation conditions exist in a pressure cooker at all times after the steady operating conditions are established. Therefore, the liquid has the properties of saturated liquid and the exiting steam has the properties of saturated vapor at the operating pressure. The amount of liquid that has evaporated, the mass flow rate of the exiting steam, and the exit velocity are

$$m = \frac{\Delta V_{\text{liquid}}}{v_f} = \frac{0.6 \text{ L}}{0.001053 \text{ m}^3/\text{kg}} \left(\frac{1 \text{ m}^3}{1000 \text{ L}} \right) = 0.570 \text{ kg}$$

$$\dot{m} = \frac{m}{\Delta t} = \frac{0.570 \text{ kg}}{40 \text{ min}} = 0.0142 \text{ kg/min} = 2.37 \times 10^{-4} \text{ kg/s}$$

$$V = \frac{\dot{m}}{\rho_g A_c} = \frac{\dot{m} v_g}{A_c} = \frac{(2.37 \times 10^{-4} \text{ kg/s})(1.1594 \text{ m}^3/\text{kg})}{8 \times 10^{-6} \text{ m}^2} = 34.3 \text{ m/s}$$

(b) Noting that $h = u + Pv$ and that the kinetic and potential energies are disregarded, the flow and total energies of the exiting steam are

$$e_{\text{flow}} = Pv = h - u = 2693.1 - 2519.2 = 173.9 \text{ kJ/kg}$$

$$\theta = h + \text{ke} + \text{pe} \cong h = 2693.1 \text{ kJ/kg}$$

Note that the kinetic energy in this case is $\text{ke} = V^2/2 = (34.3 \text{ m/s})^2/2 = 588 \text{ m}^2/\text{s}^2 = 0.588 \text{ kJ/kg}$, which is small compared to enthalpy.

(c) The rate at which energy is leaving the cooker by mass is simply the product of the mass flow rate and the total energy of the exiting steam per unit mass,

$$\dot{E}_{\text{mass}} = \dot{m}\theta = (2.37 \times 10^{-4} \text{ kg/s})(2693.1 \text{ kJ/kg}) = 0.638 \text{ kJ/s} = 0.638 \text{ kW}$$

Discussion The numerical value of the energy leaving the cooker with steam alone does not mean much since this value depends on the reference point selected for enthalpy (it could even be negative). The significant quantity is the difference between the enthalpies of the exiting vapor and the liquid inside (which is h_{fg}) since it relates directly to the amount of energy supplied to the cooker.

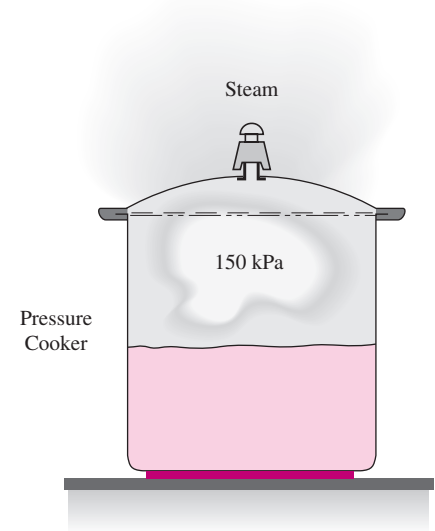

FIGURE 5–16
Schematic for Example 5–3.



**INTERACTIVE
TUTORIAL**

SEE TUTORIAL CH. 5, SEC. 3 ON THE DVD.

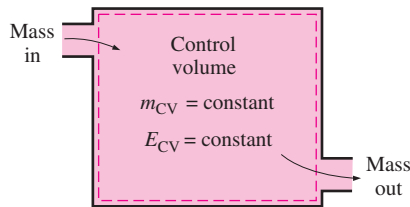
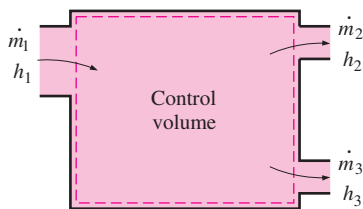

FIGURE 5-17

Many engineering systems such as power plants operate under steady conditions.

© Vol. 57/PhotoDisc

FIGURE 5-18

Under steady-flow conditions, the mass and energy contents of a control volume remain constant.

FIGURE 5-19

Under steady-flow conditions, the fluid properties at an inlet or exit remain constant (do not change with time).

5-3 ■ ENERGY ANALYSIS OF STEADY-FLOW SYSTEMS

A large number of engineering devices such as turbines, compressors, and nozzles operate for long periods of time under the same conditions once the transient start-up period is completed and steady operation is established, and they are classified as *steady-flow devices* (Fig. 5-17). Processes involving such devices can be represented reasonably well by a somewhat idealized process, called the **steady-flow process**, which was defined in Chap. 1 as *a process during which a fluid flows through a control volume steadily*. That is, the fluid properties can change from point to point within the control volume, but at any point, they remain constant during the entire process. (Remember, *steady* means *no change with time*.)

During a steady-flow process, no intensive or extensive properties *within the control volume* change with time. Thus, the volume V , the mass m , and the total energy content E of the control volume remain constant (Fig. 5-18). As a result, the boundary work is zero for steady-flow systems (since $V_{CV} = \text{constant}$), and the total mass or energy entering the control volume must be equal to the total mass or energy leaving it (since $m_{CV} = \text{constant}$ and $E_{CV} = \text{constant}$). These observations greatly simplify the analysis.

The fluid properties at an inlet or exit remain constant during a steady-flow process. The properties may, however, be different at different inlets and exits. They may even vary over the cross section of an inlet or an exit. However, all properties, including the velocity and elevation, must remain constant with time at a fixed point at an inlet or exit. It follows that the mass flow rate of the fluid at an opening must remain constant during a steady-flow process (Fig. 5-19). As an added simplification, the fluid properties at an opening are usually considered to be uniform (at some average value) over the cross section. Thus, the fluid properties at an inlet or exit may be specified by the average single values. Also, the *heat* and *work* interactions between a steady-flow system and its surroundings do not change with time. Thus, the power delivered by a system and the rate of heat transfer to or from a system remain constant during a steady-flow process.

The *mass balance* for a general steady-flow system was given in Sec. 5-1 as

$$\sum_{\text{in}} \dot{m} = \sum_{\text{out}} \dot{m} \quad (\text{kg/s}) \quad (5-31)$$

The mass balance for a single-stream (one-inlet and one-outlet) steady-flow system was given as

$$\dot{m}_1 = \dot{m}_2 \rightarrow \rho_1 V_1 A_1 = \rho_2 V_2 A_2 \quad (5-32)$$

where the subscripts 1 and 2 denote the inlet and the exit states, respectively, ρ is density, V is the average flow velocity in the flow direction, and A is the cross-sectional area normal to flow direction.

During a steady-flow process, the total energy content of a control volume remains constant ($E_{CV} = \text{constant}$), and thus the change in the total energy of the control volume is zero ($\Delta E_{CV} = 0$). Therefore, the amount of energy entering a control volume in all forms (by heat, work, and mass) must be equal to the amount of energy leaving it. Then the rate form of the general energy balance reduces for a steady-flow process to

$$\underbrace{\dot{E}_{\text{in}} - \dot{E}_{\text{out}}}_{\text{Rate of net energy transfer by heat, work, and mass}} = \underbrace{\frac{dE_{\text{system}}/dt}_{\text{Rate of change in internal, kinetic, potential, etc., energies}}}_{0 \text{ (steady)}} = 0 \quad (5-33)$$

or

$$\text{Energy balance: } \underbrace{\dot{E}_{\text{in}}}_{\text{Rate of net energy transfer in by heat, work, and mass}} = \underbrace{\dot{E}_{\text{out}}}_{\text{Rate of net energy transfer out by heat, work, and mass}} \quad (\text{kW}) \quad (5-34)$$

Noting that energy can be transferred by heat, work, and mass only, the energy balance in Eq. 5-34 for a general steady-flow system can also be written more explicitly as

$$\dot{Q}_{\text{in}} + \dot{W}_{\text{in}} + \sum_{\text{in}} \dot{m}\theta = \dot{Q}_{\text{out}} + \dot{W}_{\text{out}} + \sum_{\text{out}} \dot{m}\theta \quad (5-35)$$

or

$$\dot{Q}_{\text{in}} + \dot{W}_{\text{in}} + \sum_{\text{in}} \dot{m} \underbrace{\left(h + \frac{V^2}{2} + gz \right)}_{\text{for each inlet}} = \dot{Q}_{\text{out}} + \dot{W}_{\text{out}} + \sum_{\text{out}} \dot{m} \underbrace{\left(h + \frac{V^2}{2} + gz \right)}_{\text{for each exit}} \quad (5-36)$$

since the energy of a flowing fluid per unit mass is $\theta = h + ke + pe = h + V^2/2 + gz$. The energy balance relation for steady-flow systems first appeared in 1859 in a German thermodynamics book written by Gustav Zeuner.

Consider, for example, an ordinary electric hot-water heater under steady operation, as shown in Fig. 5-20. A cold-water stream with a mass flow rate \dot{m} is continuously flowing into the water heater, and a hot-water stream of the same mass flow rate is continuously flowing out of it. The water heater (the control volume) is losing heat to the surrounding air at a rate of \dot{Q}_{out} , and the electric heating element is supplying electrical work (heating) to the water at a rate of \dot{W}_{in} . On the basis of the conservation of energy principle, we can say that the water stream experiences an increase in its total energy as it flows through the water heater that is equal to the electric energy supplied to the water minus the heat losses.

The energy balance relation just given is intuitive in nature and is easy to use when the magnitudes and directions of heat and work transfers are known. When performing a general analytical study or solving a problem that involves an unknown heat or work interaction, however, we need to assume a direction for the heat or work interactions. In such cases, it is common practice to assume heat to be transferred *into the system* (heat input) at a rate of \dot{Q} , and work produced *by the system* (work output) at a rate of \dot{W} , and then solve the problem. The first-law or energy balance relation in that case for a general steady-flow system becomes

$$\dot{Q} - \dot{W} = \sum_{\text{out}} \dot{m} \underbrace{\left(h + \frac{V^2}{2} + gz \right)}_{\text{for each exit}} - \sum_{\text{in}} \dot{m} \underbrace{\left(h + \frac{V^2}{2} + gz \right)}_{\text{for each inlet}} \quad (5-37)$$

Obtaining a negative quantity for \dot{Q} or \dot{W} simply means that the assumed direction is wrong and should be reversed. For single-stream devices, the steady-flow energy balance equation becomes

$$\dot{Q} - \dot{W} = \dot{m} \left[h_2 - h_1 + \frac{V_2^2 - V_1^2}{2} + g(z_2 - z_1) \right] \quad (5-38)$$

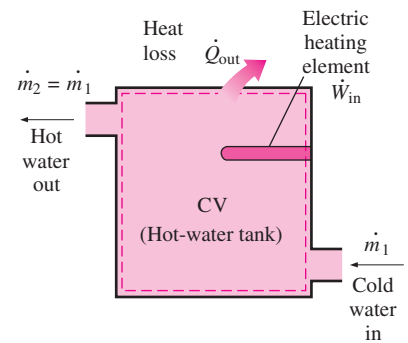

FIGURE 5-20

A water heater in steady operation.

Dividing Eq. 5–38 by \dot{m} gives the energy balance on a unit-mass basis as

$$q - w = h_2 - h_1 + \frac{V_2^2 - V_1^2}{2} + g(z_2 - z_1) \quad (5-39)$$

where $q = \dot{Q}/\dot{m}$ and $w = \dot{W}/\dot{m}$ are the heat transfer and work done per unit mass of the working fluid, respectively. When the fluid experiences negligible changes in its kinetic and potential energies (that is, $\Delta ke \cong 0$, $\Delta pe \cong 0$), the energy balance equation is reduced further to

$$q - w = h_2 - h_1 \quad (5-40)$$

The various terms appearing in the above equations are as follows:

\dot{Q} = **rate of heat transfer between the control volume and its surroundings.**

When the control volume is losing heat (as in the case of the water heater), \dot{Q} is negative. If the control volume is well insulated (i.e., adiabatic), then $\dot{Q} = 0$.

\dot{W} = **power.** For steady-flow devices, the control volume is constant; thus, there is no boundary work involved. The work required to push mass into and out of the control volume is also taken care of by using enthalpies for the energy of fluid streams instead of internal energies. Then \dot{W} represents the remaining forms of work done per unit time (Fig. 5–21). Many steady-flow devices, such as turbines, compressors, and pumps, transmit power through a shaft, and \dot{W} simply becomes the shaft power for those devices. If the control surface is crossed by electric wires (as in the case of an electric water heater), \dot{W} represents the electrical work done per unit time. If neither is present, then $\dot{W} = 0$.

$\Delta h = h_2 - h_1$. The enthalpy change of a fluid can easily be determined by reading the enthalpy values at the exit and inlet states from the tables. For ideal gases, it can be approximated by $\Delta h = c_{p,avg}(T_2 - T_1)$. Note that $(\text{kg/s})(\text{kJ/kg}) \equiv \text{kW}$.

$\Delta ke = (V_2^2 - V_1^2)/2$. The unit of kinetic energy is m^2/s^2 , which is equivalent to J/kg (Fig. 5–22). The enthalpy is usually given in kJ/kg . To add these two quantities, the kinetic energy should be expressed in kJ/kg . This is easily accomplished by dividing it by 1000. A velocity of 45 m/s corresponds to a kinetic energy of only 1 kJ/kg , which is a very small value compared with the enthalpy values encountered in practice. Thus, the kinetic energy term at low velocities can be neglected. When a fluid stream enters and leaves a steady-flow device at about the same velocity ($V_1 \cong V_2$), the change in the kinetic energy is close to zero regardless of the velocity. Caution should be exercised at high velocities, however, since small changes in velocities may cause significant changes in kinetic energy (Fig. 5–23).

$\Delta pe = g(z_2 - z_1)$. A similar argument can be given for the potential energy term. A potential energy change of 1 kJ/kg corresponds to an elevation difference of 102 m. The elevation difference between the inlet and exit of most industrial devices such as turbines and compressors is well below this value, and the potential energy term is always neglected for these devices. The only time the potential energy term is significant is when a process involves pumping a fluid to high elevations and we are interested in the required pumping power.

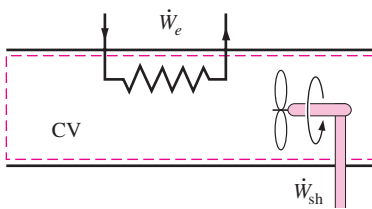

FIGURE 5–21

Under steady operation, shaft work and electrical work are the only forms of work a simple compressible system may involve.

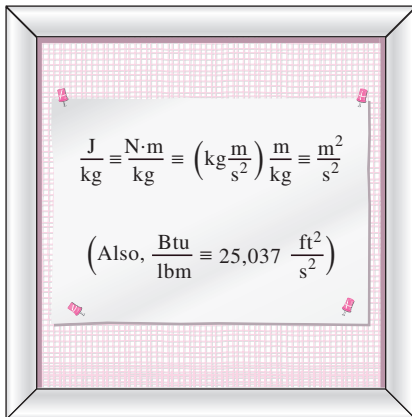

FIGURE 5–22

The units m^2/s^2 and J/kg are equivalent.

5-4 ■ SOME STEADY-FLOW ENGINEERING DEVICES

Many engineering devices operate essentially under the same conditions for long periods of time. The components of a steam power plant (turbines, compressors, heat exchangers, and pumps), for example, operate nonstop for months before the system is shut down for maintenance (Fig. 5–24). Therefore, these devices can be conveniently analyzed as steady-flow devices.

In this section, some common steady-flow devices are described, and the thermodynamic aspects of the flow through them are analyzed. The conservation of mass and the conservation of energy principles for these devices are illustrated with examples.

1 Nozzles and Diffusers

Nozzles and diffusers are commonly utilized in jet engines, rockets, spacecraft, and even garden hoses. A **nozzle** is a device that *increases the velocity of a fluid* at the expense of pressure. A **diffuser** is a device that *increases the pressure of a fluid* by slowing it down. That is, nozzles and diffusers perform opposite tasks. The cross-sectional area of a nozzle decreases in the flow direction for subsonic flows and increases for supersonic flows. The reverse is true for diffusers.

The rate of heat transfer between the fluid flowing through a nozzle or a diffuser and the surroundings is usually very small ($\dot{Q} \approx 0$) since the fluid has high velocities, and thus it does not spend enough time in the device for any significant heat transfer to take place. Nozzles and diffusers typically involve no work ($\dot{W} = 0$) and any change in potential energy is negligible ($\Delta pe \cong 0$). But nozzles and diffusers usually involve very high velocities, and as a fluid passes through a nozzle or diffuser, it experiences large changes in its velocity (Fig. 5–25). Therefore, the kinetic energy changes must be accounted for in analyzing the flow through these devices ($\Delta ke \neq 0$).

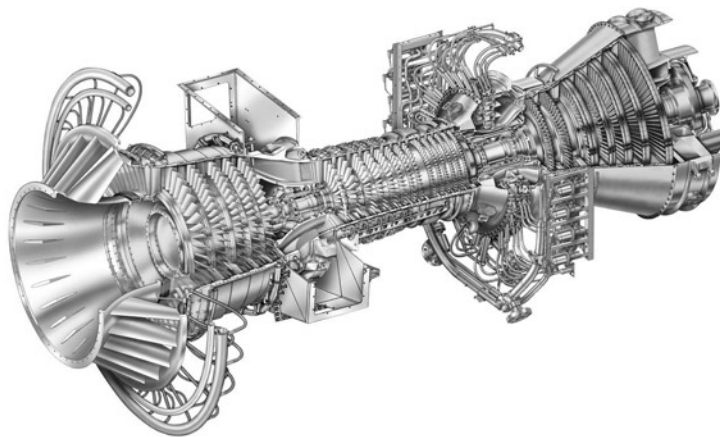

FIGURE 5–24

A modern land-based gas turbine used for electric power production. This is a General Electric LM5000 turbine. It has a length of 6.2 m, it weighs 12.5 tons, and produces 55.2 MW at 3600 rpm with steam injection.

Courtesy of GE Power Systems



**INTERACTIVE
TUTORIAL**

SEE TUTORIAL CH. 5, SEC. 4 ON THE DVD.

	V_1	V_2	Δke
	m/s	m/s	kJ/kg
	0	45	1
	50	67	1
	100	110	1
	200	205	1
	500	502	1

FIGURE 5–23

At very high velocities, even small changes in velocities can cause significant changes in the kinetic energy of the fluid.

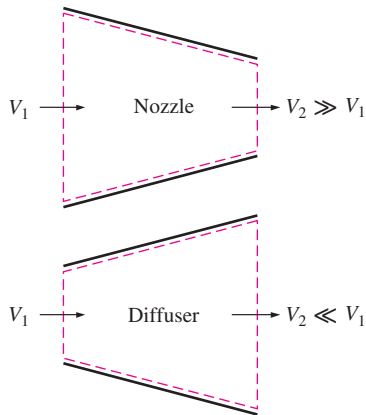

FIGURE 5-25

Nozzles and diffusers are shaped so that they cause large changes in fluid velocities and thus kinetic energies.

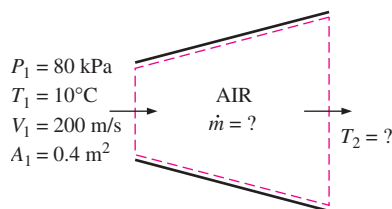

FIGURE 5-26

Schematic for Example 5-4.

EXAMPLE 5-4 Deceleration of Air in a Diffuser

Air at 10°C and 80 kPa enters the diffuser of a jet engine steadily with a velocity of 200 m/s. The inlet area of the diffuser is 0.4 m². The air leaves the diffuser with a velocity that is very small compared with the inlet velocity. Determine (a) the mass flow rate of the air and (b) the temperature of the air leaving the diffuser.

Solution Air enters the diffuser of a jet engine steadily at a specified velocity. The mass flow rate of air and the temperature at the diffuser exit are to be determined.

Assumptions **1** This is a steady-flow process since there is no change with time at any point and thus $\Delta m_{CV} = 0$ and $\Delta E_{CV} = 0$. **2** Air is an ideal gas since it is at a high temperature and low pressure relative to its critical-point values. **3** The potential energy change is zero, $\Delta pe = 0$. **4** Heat transfer is negligible. **5** Kinetic energy at the diffuser exit is negligible. **6** There are no work interactions.

Analysis We take the *diffuser* as the system (Fig. 5-26). This is a *control volume* since mass crosses the system boundary during the process. We observe that there is only one inlet and one exit and thus $\dot{m}_1 = \dot{m}_2 = \dot{m}$.

(a) To determine the mass flow rate, we need to find the specific volume of the air first. This is determined from the ideal-gas relation at the inlet conditions:

$$v_1 = \frac{RT_1}{P_1} = \frac{0.287 \text{ kPa} \cdot \text{m}^3/\text{kg} \cdot \text{K} (283 \text{ K})}{80 \text{ kPa}} = 1.015 \text{ m}^3/\text{kg}$$

Then,

$$\dot{m} = \frac{1}{v_1} V_1 A_1 = \frac{1}{1.015 \text{ m}^3/\text{kg}} (200 \text{ m/s})(0.4 \text{ m}^2) = \mathbf{78.8 \text{ kg/s}}$$

Since the flow is steady, the mass flow rate through the entire diffuser remains constant at this value.

(b) Under stated assumptions and observations, the energy balance for this steady-flow system can be expressed in the rate form as

$$\underbrace{\dot{E}_{\text{in}} - \dot{E}_{\text{out}}}_{\text{Rate of net energy transfer by heat, work, and mass}} = \underbrace{\frac{dE_{\text{system}}/dt}_{\text{Rate of change in internal, kinetic, potential, etc., energies}}}_{0 \text{ (steady)}} = 0$$

$$\begin{aligned} \dot{E}_{\text{in}} &= \dot{E}_{\text{out}} \\ \dot{m} \left(h_1 + \frac{V_1^2}{2} \right) &= \dot{m} \left(h_2 + \frac{V_2^2}{2} \right) \quad (\text{since } \dot{Q} \cong 0, \dot{W} = 0, \text{ and } \Delta pe \cong 0) \\ h_2 &= h_1 - \frac{V_2^2 - V_1^2}{2} \end{aligned}$$

The exit velocity of a diffuser is usually small compared with the inlet velocity ($V_2 \ll V_1$); thus, the kinetic energy at the exit can be neglected. The enthalpy of air at the diffuser inlet is determined from the air table (Table A-17) to be

$$h_1 = h_{@ 283 \text{ K}} = 283.14 \text{ kJ/kg}$$

Substituting, we get

$$\begin{aligned} h_2 &= 283.14 \text{ kJ/kg} - \frac{0 - (200 \text{ m/s})^2}{2} \left(\frac{1 \text{ kJ/kg}}{1000 \text{ m}^2/\text{s}^2} \right) \\ &= 303.14 \text{ kJ/kg} \end{aligned}$$

From Table A-17, the temperature corresponding to this enthalpy value is

$$T_2 = \mathbf{303 \text{ K}}$$

Discussion This result shows that the temperature of the air increases by about 20°C as it is slowed down in the diffuser. The temperature rise of the air is mainly due to the conversion of kinetic energy to internal energy.

EXAMPLE 5-5 Acceleration of Steam in a Nozzle

Steam at 250 psia and 700°F steadily enters a nozzle whose inlet area is 0.2 ft². The mass flow rate of steam through the nozzle is 10 lbm/s. Steam leaves the nozzle at 200 psia with a velocity of 900 ft/s. Heat losses from the nozzle per unit mass of the steam are estimated to be 1.2 Btu/lbm. Determine (a) the inlet velocity and (b) the exit temperature of the steam.

Solution Steam enters a nozzle steadily at a specified flow rate and velocity. The inlet velocity of steam and the exit temperature are to be determined.

Assumptions **1** This is a steady-flow process since there is no change with time at any point and thus $\Delta m_{\text{CV}} = 0$ and $\Delta E_{\text{CV}} = 0$. **2** There are no work interactions. **3** The potential energy change is zero, $\Delta \text{pe} = 0$.

Analysis We take the *nozzle* as the system (Fig. 5-26A). This is a *control volume* since mass crosses the system boundary during the process. We observe that there is only one inlet and one exit and thus $\dot{m}_1 = \dot{m}_2 = \dot{m}$.

(a) The specific volume and enthalpy of steam at the nozzle inlet are

$$\left. \begin{aligned} P_1 &= 250 \text{ psia} \\ T_1 &= 700^\circ\text{F} \end{aligned} \right\} \begin{aligned} v_1 &= 2.6883 \text{ ft}^3/\text{lbm} \\ h_1 &= 1371.4 \text{ Btu/lbm} \end{aligned} \quad (\text{Table A-6E})$$

Then,

$$\begin{aligned} \dot{m} &= \frac{1}{v_1} V_1 A_1 \\ 10 \text{ lbm/s} &= \frac{1}{2.6883 \text{ ft}^3/\text{lbm}} (V_1)(0.2 \text{ ft}^2) \\ V_1 &= \mathbf{134.4 \text{ ft/s}} \end{aligned}$$

(b) Under stated assumptions and observations, the energy balance for this steady-flow system can be expressed in the rate form as

$$\underbrace{\dot{E}_{\text{in}} - \dot{E}_{\text{out}}}_{\substack{\text{Rate of net energy transfer} \\ \text{by heat, work, and mass}}} = \underbrace{\frac{dE_{\text{system}}/dt}_{\substack{\text{Rate of change in internal, kinetic,} \\ \text{potential, etc., energies}}}}_{\substack{0 \text{ (steady)}}} = 0$$

$$\dot{E}_{\text{in}} = \dot{E}_{\text{out}}$$

$$\dot{m} \left(h_1 + \frac{V_1^2}{2} \right) = \dot{Q}_{\text{out}} + \dot{m} \left(h_2 + \frac{V_2^2}{2} \right) \quad (\text{since } \dot{W} = 0, \text{ and } \Delta \text{pe} \cong 0)$$

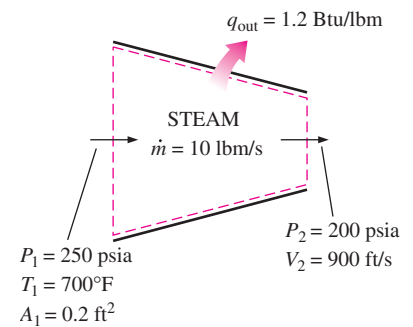

FIGURE 5-26A

Schematic for Example 5-5.

Dividing by the mass flow rate \dot{m} and substituting, h_2 is determined to be

$$\begin{aligned} h_2 &= h_1 - q_{\text{out}} - \frac{V_2^2 - V_1^2}{2} \\ &= (1371.4 - 1.2) \text{ Btu/lbm} - \frac{(900 \text{ ft/s})^2 - (134.4 \text{ ft/s})^2}{2} \left(\frac{1 \text{ Btu/lbm}}{25,037 \text{ ft}^2/\text{s}^2} \right) \\ &= 1354.4 \text{ Btu/lbm} \end{aligned}$$

Then,

$$\left. \begin{aligned} P_2 &= 200 \text{ psia} \\ h_2 &= 1354.4 \text{ Btu/lbm} \end{aligned} \right\} T_2 = \mathbf{662.0^\circ\text{F}} \quad (\text{Table A-6E})$$

Discussion Note that the temperature of steam drops by 38.0°F as it flows through the nozzle. This drop in temperature is mainly due to the conversion of internal energy to kinetic energy. (The heat loss is too small to cause any significant effect in this case.)

2 Turbines and Compressors

In steam, gas, or hydroelectric power plants, the device that drives the electric generator is the turbine. As the fluid passes through the turbine, work is done against the blades, which are attached to the shaft. As a result, the shaft rotates, and the turbine produces work.

Compressors, as well as pumps and fans, are devices used to increase the pressure of a fluid. Work is supplied to these devices from an external source through a rotating shaft. Therefore, compressors involve work inputs. Even though these three devices function similarly, they do differ in the tasks they perform. A *fan* increases the pressure of a gas slightly and is mainly used to mobilize a gas. A *compressor* is capable of compressing the gas to very high pressures. *Pumps* work very much like compressors except that they handle liquids instead of gases.

Note that turbines produce power output whereas compressors, pumps, and fans require power input. Heat transfer from turbines is usually negligible ($\dot{Q} \approx 0$) since they are typically well insulated. Heat transfer is also negligible for compressors unless there is intentional cooling. Potential energy changes are negligible for all of these devices ($\Delta p_e \cong 0$). The velocities involved in these devices, with the exception of turbines and fans, are usually too low to cause any significant change in the kinetic energy ($\Delta k_e \cong 0$). The fluid velocities encountered in most turbines are very high, and the fluid experiences a significant change in its kinetic energy. However, this change is usually very small relative to the change in enthalpy, and thus it is often disregarded.

EXAMPLE 5-6 Compressing Air by a Compressor

Air at 100 kPa and 280 K is compressed steadily to 600 kPa and 400 K. The mass flow rate of the air is 0.02 kg/s, and a heat loss of 16 kJ/kg occurs during the process. Assuming the changes in kinetic and potential energies are negligible, determine the necessary power input to the compressor.

Solution Air is compressed steadily by a compressor to a specified temperature and pressure. The power input to the compressor is to be determined.

Assumptions **1** This is a steady-flow process since there is no change with time at any point and thus $\Delta m_{CV} = 0$ and $\Delta E_{CV} = 0$. **2** Air is an ideal gas since it is at a high temperature and low pressure relative to its critical-point values. **3** The kinetic and potential energy changes are zero, $\Delta ke = \Delta pe = 0$.

Analysis We take the *compressor* as the system (Fig. 5–27). This is a *control volume* since mass crosses the system boundary during the process. We observe that there is only one inlet and one exit and thus $\dot{m}_1 = \dot{m}_2 = \dot{m}$. Also, heat is lost from the system and work is supplied to the system.

Under stated assumptions and observations, the energy balance for this steady-flow system can be expressed in the rate form as

$$\underbrace{\dot{E}_{in} - \dot{E}_{out}}_{\text{Rate of net energy transfer by heat, work, and mass}} = \underbrace{\frac{dE_{system}}{dt}}_{\text{Rate of change in internal, kinetic, potential, etc., energies}} \overset{0 \text{ (steady)}}{=} 0$$

$$\dot{E}_{in} = \dot{E}_{out}$$

$$\dot{W}_{in} + \dot{m}h_1 = \dot{Q}_{out} + \dot{m}h_2 \quad (\text{since } \Delta ke = \Delta pe \cong 0)$$

$$\dot{W}_{in} = \dot{m}q_{out} + \dot{m}(h_2 - h_1)$$

The enthalpy of an ideal gas depends on temperature only, and the enthalpies of the air at the specified temperatures are determined from the air table (Table A–17) to be

$$h_1 = h_{@ 280 \text{ K}} = 280.13 \text{ kJ/kg}$$

$$h_2 = h_{@ 400 \text{ K}} = 400.98 \text{ kJ/kg}$$

Substituting, the power input to the compressor is determined to be

$$\begin{aligned} \dot{W}_{in} &= (0.02 \text{ kg/s})(16 \text{ kJ/kg}) + (0.02 \text{ kg/s})(400.98 - 280.13) \text{ kJ/kg} \\ &= \mathbf{2.74 \text{ kW}} \end{aligned}$$

Discussion Note that the mechanical energy input to the compressor manifests itself as a rise in enthalpy of air and heat loss from the compressor.

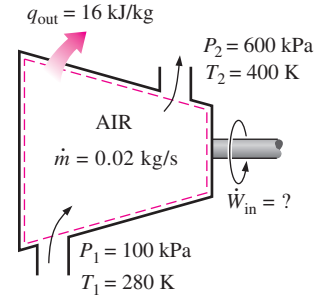

FIGURE 5–27
Schematic for Example 5–6.

EXAMPLE 5–7 Power Generation by a Steam Turbine

The power output of an adiabatic steam turbine is 5 MW, and the inlet and the exit conditions of the steam are as indicated in Fig. 5–28.

- (a) Compare the magnitudes of Δh , Δke , and Δpe .
- (b) Determine the work done per unit mass of the steam flowing through the turbine.
- (c) Calculate the mass flow rate of the steam.

Solution The inlet and exit conditions of a steam turbine and its power output are given. The changes in kinetic energy, potential energy, and enthalpy of steam, as well as the work done per unit mass and the mass flow rate of steam are to be determined.

Assumptions **1** This is a steady-flow process since there is no change with time at any point and thus $\Delta m_{CV} = 0$ and $\Delta E_{CV} = 0$. **2** The system is adiabatic and thus there is no heat transfer.

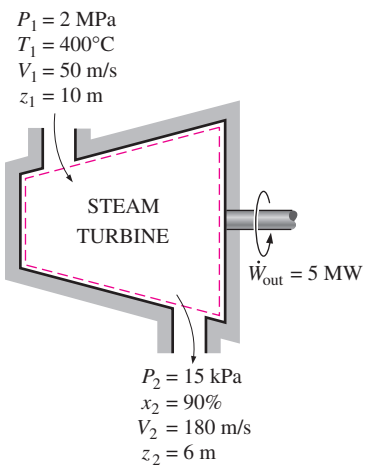

FIGURE 5–28
Schematic for Example 5–7.

Analysis We take the *turbine* as the system. This is a *control volume* since mass crosses the system boundary during the process. We observe that there is only one inlet and one exit and thus $\dot{m}_1 = \dot{m}_2 = \dot{m}$. Also, work is done by the system. The inlet and exit velocities and elevations are given, and thus the kinetic and potential energies are to be considered.

(a) At the inlet, steam is in a superheated vapor state, and its enthalpy is

$$\left. \begin{array}{l} P_1 = 2 \text{ MPa} \\ T_1 = 400^\circ\text{C} \end{array} \right\} h_1 = 3248.4 \text{ kJ/kg} \quad (\text{Table A-6})$$

At the turbine exit, we obviously have a saturated liquid–vapor mixture at 15-kPa pressure. The enthalpy at this state is

$$h_2 = h_f + x_2 h_{fg} = [225.94 + (0.9)(2372.3)] \text{ kJ/kg} = 2361.01 \text{ kJ/kg}$$

Then

$$\Delta h = h_2 - h_1 = (2361.01 - 3248.4) \text{ kJ/kg} = \mathbf{-887.39 \text{ kJ/kg}}$$

$$\Delta \text{ke} = \frac{V_2^2 - V_1^2}{2} = \frac{(180 \text{ m/s})^2 - (50 \text{ m/s})^2}{2} \left(\frac{1 \text{ kJ/kg}}{1000 \text{ m}^2/\text{s}^2} \right) = \mathbf{14.95 \text{ kJ/kg}}$$

$$\Delta \text{pe} = g(z_2 - z_1) = (9.81 \text{ m/s}^2)[(6 - 10) \text{ m}] \left(\frac{1 \text{ kJ/kg}}{1000 \text{ m}^2/\text{s}^2} \right) = \mathbf{-0.04 \text{ kJ/kg}}$$

(b) The energy balance for this steady-flow system can be expressed in the rate form as

$$\underbrace{\dot{E}_{\text{in}} - \dot{E}_{\text{out}}}_{\substack{\text{Rate of net energy transfer} \\ \text{by heat, work, and mass}}} = \underbrace{\frac{dE_{\text{system}}/dt}_{\substack{\text{Rate of change in internal, kinetic,} \\ \text{potential, etc., energies}}}}_{\substack{0 \text{ (steady)}}} = 0$$

$$\dot{E}_{\text{in}} = \dot{E}_{\text{out}}$$

$$\dot{m} \left(h_1 + \frac{V_1^2}{2} + gz_1 \right) = \dot{W}_{\text{out}} + \dot{m} \left(h_2 + \frac{V_2^2}{2} + gz_2 \right) \quad (\text{since } \dot{Q} = 0)$$

Dividing by the mass flow rate \dot{m} and substituting, the work done by the turbine per unit mass of the steam is determined to be

$$\begin{aligned} w_{\text{out}} &= - \left[(h_2 - h_1) + \frac{V_2^2 - V_1^2}{2} + g(z_2 - z_1) \right] = -(\Delta h + \Delta \text{ke} + \Delta \text{pe}) \\ &= -[-887.39 + 14.95 - 0.04] \text{ kJ/kg} = \mathbf{872.48 \text{ kJ/kg}} \end{aligned}$$

(c) The required mass flow rate for a 5-MW power output is

$$\dot{m} = \frac{\dot{W}_{\text{out}}}{w_{\text{out}}} = \frac{5000 \text{ kJ/s}}{872.48 \text{ kJ/kg}} = \mathbf{5.73 \text{ kg/s}}$$

Discussion Two observations can be made from these results. First, the change in potential energy is insignificant in comparison to the changes in enthalpy and kinetic energy. This is typical for most engineering devices. Second, as a result of low pressure and thus high specific volume, the steam velocity at the turbine exit can be very high. Yet the change in kinetic energy is a small fraction of the change in enthalpy (less than 2 percent in our case) and is therefore often neglected.

3 Throttling Valves

Throttling valves are *any kind of flow-restricting devices* that cause a significant pressure drop in the fluid. Some familiar examples are ordinary adjustable valves, capillary tubes, and porous plugs (Fig. 5–29). Unlike turbines, they produce a pressure drop without involving any work. The pressure drop in the fluid is often accompanied by a *large drop in temperature*, and for that reason throttling devices are commonly used in refrigeration and air-conditioning applications. The magnitude of the temperature drop (or, sometimes, the temperature rise) during a throttling process is governed by a property called the *Joule-Thomson coefficient*, discussed in Chap. 12.

Throttling valves are usually small devices, and the flow through them may be assumed to be adiabatic ($q \cong 0$) since there is neither sufficient time nor large enough area for any effective heat transfer to take place. Also, there is no work done ($w = 0$), and the change in potential energy, if any, is very small ($\Delta pe \cong 0$). Even though the exit velocity is often considerably higher than the inlet velocity, in many cases, the increase in kinetic energy is insignificant ($\Delta ke \cong 0$). Then the conservation of energy equation for this single-stream steady-flow device reduces to

$$h_2 \cong h_1 \quad (\text{kJ/kg}) \quad (5-41)$$

That is, enthalpy values at the inlet and exit of a throttling valve are the same. For this reason, a throttling valve is sometimes called an *isenthalpic device*. Note, however, that for throttling devices with large exposed surface areas such as capillary tubes, heat transfer may be significant.

To gain some insight into how throttling affects fluid properties, let us express Eq. 5–41 as follows:

$$u_1 + P_1 v_1 = u_2 + P_2 v_2$$

or

$$\text{Internal energy} + \text{Flow energy} = \text{Constant}$$

Thus the final outcome of a throttling process depends on which of the two quantities increases during the process. If the flow energy increases during the process ($P_2 v_2 > P_1 v_1$), it can do so at the expense of the internal energy. As a result, internal energy decreases, which is usually accompanied by a drop in temperature. If the product Pv decreases, the internal energy and the temperature of a fluid will increase during a throttling process. In the case of an ideal gas, $h = h(T)$, and thus the temperature has to remain constant during a throttling process (Fig. 5–30).

EXAMPLE 5–8 Expansion of Refrigerant-134a in a Refrigerator

Refrigerant-134a enters the capillary tube of a refrigerator as saturated liquid at 0.8 MPa and is throttled to a pressure of 0.12 MPa. Determine the quality of the refrigerant at the final state and the temperature drop during this process.

Solution Refrigerant-134a that enters a capillary tube as saturated liquid is throttled to a specified pressure. The exit quality of the refrigerant and the temperature drop are to be determined.

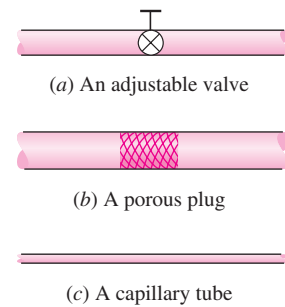

FIGURE 5–29

Throttling valves are devices that cause large pressure drops in the fluid.

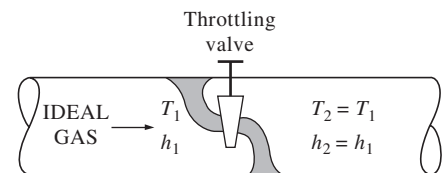

FIGURE 5–30

The temperature of an ideal gas does not change during a throttling ($h = \text{constant}$) process since $h = h(T)$.

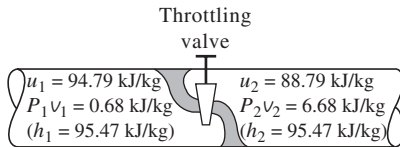

FIGURE 5–31

During a throttling process, the enthalpy (flow energy + internal energy) of a fluid remains constant. But internal and flow energies may be converted to each other.

Assumptions 1 Heat transfer from the tube is negligible. 2 Kinetic energy change of the refrigerant is negligible.

Analysis A capillary tube is a simple flow-restricting device that is commonly used in refrigeration applications to cause a large pressure drop in the refrigerant. Flow through a capillary tube is a throttling process; thus, the enthalpy of the refrigerant remains constant (Fig. 5–31).

$$\text{At inlet: } \left. \begin{array}{l} P_1 = 0.8 \text{ MPa} \\ \text{sat. liquid} \end{array} \right\} \begin{array}{l} T_1 = T_{\text{sat @ } 0.8 \text{ MPa}} = 31.31^\circ\text{C} \\ h_1 = h_f @ 0.8 \text{ MPa} = 95.47 \text{ kJ/kg} \end{array} \quad (\text{Table A-12})$$

$$\text{At exit: } \begin{array}{l} P_2 = 0.12 \text{ MPa} \\ (h_2 = h_1) \end{array} \longrightarrow \begin{array}{l} h_f = 22.49 \text{ kJ/kg} \\ h_g = 236.97 \text{ kJ/kg} \end{array} \quad T_{\text{sat}} = -22.32^\circ\text{C}$$

Obviously $h_f < h_2 < h_g$; thus, the refrigerant exists as a saturated mixture at the exit state. The quality at this state is

$$x_2 = \frac{h_2 - h_f}{h_{fg}} = \frac{95.47 - 22.49}{236.97 - 22.49} = \mathbf{0.340}$$

Since the exit state is a saturated mixture at 0.12 MPa, the exit temperature must be the saturation temperature at this pressure, which is -22.32°C . Then the temperature change for this process becomes

$$\Delta T = T_2 - T_1 = (-22.32 - 31.31)^\circ\text{C} = \mathbf{-53.63^\circ\text{C}}$$

Discussion Note that the temperature of the refrigerant drops by 53.63°C during this throttling process. Also note that 34.0 percent of the refrigerant vaporizes during this throttling process, and the energy needed to vaporize this refrigerant is absorbed from the refrigerant itself.

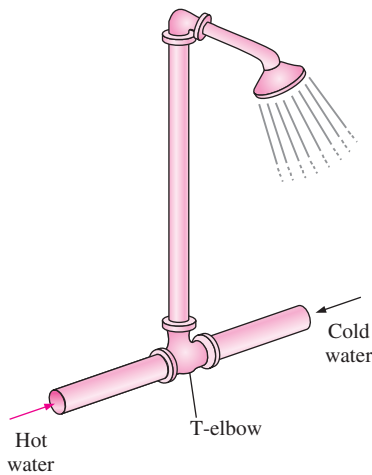

FIGURE 5–32

The T-elbow of an ordinary shower serves as the mixing chamber for the hot- and the cold-water streams.

4a Mixing Chambers

In engineering applications, mixing two streams of fluids is not a rare occurrence. The section where the mixing process takes place is commonly referred to as a **mixing chamber**. The mixing chamber does not have to be a distinct “chamber.” An ordinary T-elbow or a Y-elbow in a shower, for example, serves as the mixing chamber for the cold- and hot-water streams (Fig. 5–32).

The conservation of mass principle for a mixing chamber requires that the sum of the incoming mass flow rates equal the mass flow rate of the outgoing mixture.

Mixing chambers are usually well insulated ($q \cong 0$) and usually do not involve any kind of work ($w = 0$). Also, the kinetic and potential energies of the fluid streams are usually negligible ($ke \cong 0$, $pe \cong 0$). Then all there is left in the energy equation is the total energies of the incoming streams and the outgoing mixture. The conservation of energy principle requires that these two equal each other. Therefore, the conservation of energy equation becomes analogous to the conservation of mass equation for this case.

EXAMPLE 5–9 Mixing of Hot and Cold Waters in a Shower

Consider an ordinary shower where hot water at 140°F is mixed with cold water at 50°F. If it is desired that a steady stream of warm water at 110°F be supplied, determine the ratio of the mass flow rates of the hot to cold water. Assume the heat losses from the mixing chamber to be negligible and the mixing to take place at a pressure of 20 psia.

Solution In a shower, cold water is mixed with hot water at a specified temperature. For a specified mixture temperature, the ratio of the mass flow rates of the hot to cold water is to be determined.

Assumptions **1** This is a steady-flow process since there is no change with time at any point and thus $\Delta m_{CV} = 0$ and $\Delta E_{CV} = 0$. **2** The kinetic and potential energies are negligible, $ke \cong pe \cong 0$. **3** Heat losses from the system are negligible and thus $\dot{Q} \cong 0$. **4** There is no work interaction involved.

Analysis We take the *mixing chamber* as the system (Fig. 5–33). This is a *control volume* since mass crosses the system boundary during the process. We observe that there are two inlets and one exit.

Under the stated assumptions and observations, the mass and energy balances for this steady-flow system can be expressed in the rate form as follows:

$$\text{Mass balance: } \dot{m}_{\text{in}} - \dot{m}_{\text{out}} = \frac{dm_{\text{system}}/dt}{\text{Rate of change in mass}} \xrightarrow{0 \text{ (steady)}} = 0$$

$$\dot{m}_{\text{in}} = \dot{m}_{\text{out}} \rightarrow \dot{m}_1 + \dot{m}_2 = \dot{m}_3$$

$$\text{Energy balance: } \underbrace{\dot{E}_{\text{in}} - \dot{E}_{\text{out}}}_{\text{Rate of net energy transfer by heat, work, and mass}} = \underbrace{\frac{dE_{\text{system}}/dt}_{\text{Rate of change in internal, kinetic, potential, etc., energies}}}_{\text{Rate of change in internal, kinetic, potential, etc., energies}} \xrightarrow{0 \text{ (steady)}} = 0$$

$$\dot{E}_{\text{in}} = \dot{E}_{\text{out}}$$

$$\dot{m}_1 h_1 + \dot{m}_2 h_2 = \dot{m}_3 h_3 \quad (\text{since } \dot{Q} \cong 0, \dot{W} = 0, ke \cong pe \cong 0)$$

Combining the mass and energy balances,

$$\dot{m}_1 h_1 + \dot{m}_2 h_2 = (\dot{m}_1 + \dot{m}_2) h_3$$

Dividing this equation by \dot{m}_2 yields

$$y h_1 + h_2 = (y + 1) h_3$$

where $y = \dot{m}_1/\dot{m}_2$ is the desired mass flow rate ratio.

The saturation temperature of water at 20 psia is 227.92°F. Since the temperatures of all three streams are below this value ($T < T_{\text{sat}}$), the water in all three streams exists as a compressed liquid (Fig. 5–34). A compressed liquid can be approximated as a saturated liquid at the given temperature. Thus,

$$h_1 \cong h_f @ 140^\circ\text{F} = 107.99 \text{ Btu/lbm}$$

$$h_2 \cong h_f @ 50^\circ\text{F} = 18.07 \text{ Btu/lbm}$$

$$h_3 \cong h_f @ 110^\circ\text{F} = 78.02 \text{ Btu/lbm}$$

Solving for y and substituting yields

$$y = \frac{h_3 - h_2}{h_1 - h_3} = \frac{78.02 - 18.07}{107.99 - 78.02} = 2.0$$

Discussion Note that the mass flow rate of the hot water must be twice the mass flow rate of the cold water for the mixture to leave at 110°F.

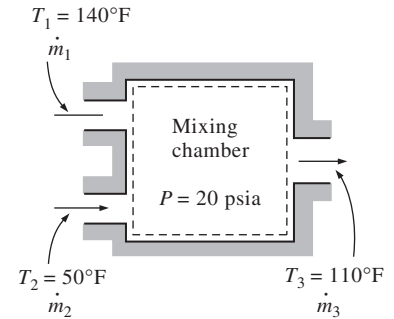

FIGURE 5–33
Schematic for Example 5–9.

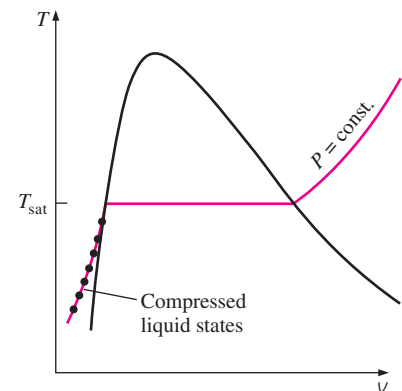

FIGURE 5–34
A substance exists as a compressed liquid at temperatures below the saturation temperatures at the given pressure.

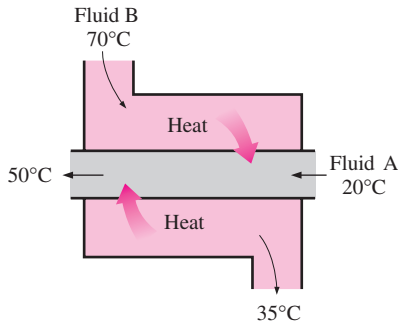

FIGURE 5-35

A heat exchanger can be as simple as two concentric pipes.

4b Heat Exchangers

As the name implies, **heat exchangers** are devices where two moving fluid streams exchange heat without mixing. Heat exchangers are widely used in various industries, and they come in various designs.

The simplest form of a heat exchanger is a *double-tube* (also called *tube-and-shell*) heat exchanger, shown in Fig. 5-35. It is composed of two concentric pipes of different diameters. One fluid flows in the inner pipe, and the other in the annular space between the two pipes. Heat is transferred from the hot fluid to the cold one through the wall separating them. Sometimes the inner tube makes a couple of turns inside the shell to increase the heat transfer area, and thus the rate of heat transfer. The mixing chambers discussed earlier are sometimes classified as *direct-contact* heat exchangers.

The conservation of mass principle for a heat exchanger in steady operation requires that the sum of the inbound mass flow rates equal the sum of the outbound mass flow rates. This principle can also be expressed as follows: *Under steady operation, the mass flow rate of each fluid stream flowing through a heat exchanger remains constant.*

Heat exchangers typically involve no work interactions ($w = 0$) and negligible kinetic and potential energy changes ($\Delta ke \cong 0$, $\Delta pe \cong 0$) for each fluid stream. The heat transfer rate associated with heat exchangers depends on how the control volume is selected. Heat exchangers are intended for heat transfer between two fluids *within* the device, and the outer shell is usually well insulated to prevent any heat loss to the surrounding medium.

When the entire heat exchanger is selected as the control volume, \dot{Q} becomes zero, since the boundary for this case lies just beneath the insulation and little or no heat crosses the boundary (Fig. 5-36). If, however, only one of the fluids is selected as the control volume, then heat will cross this boundary as it flows from one fluid to the other and \dot{Q} will not be zero. In fact, \dot{Q} in this case will be the rate of heat transfer between the two fluids.

EXAMPLE 5-10 Cooling of Refrigerant-134a by Water

Refrigerant-134a is to be cooled by water in a condenser. The refrigerant enters the condenser with a mass flow rate of 6 kg/min at 1 MPa and 70°C and leaves at 35°C. The cooling water enters at 300 kPa and 15°C and leaves

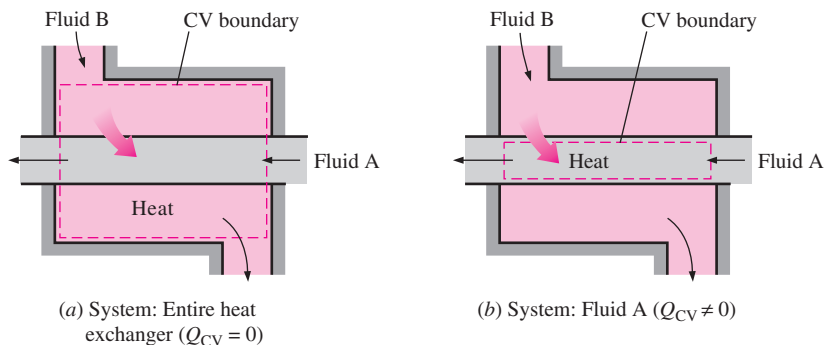

FIGURE 5-36

The heat transfer associated with a heat exchanger may be zero or nonzero depending on how the control volume is selected.

at 25°C. Neglecting any pressure drops, determine (a) the mass flow rate of the cooling water required and (b) the heat transfer rate from the refrigerant to the water.

Solution Refrigerant-134a is cooled by water in a condenser. The mass flow rate of the cooling water and the rate of heat transfer from the refrigerant to the water are to be determined.

Assumptions **1** This is a steady-flow process since there is no change with time at any point and thus $\Delta m_{CV} = 0$ and $\Delta E_{CV} = 0$. **2** The kinetic and potential energies are negligible, $ke \cong pe \cong 0$. **3** Heat losses from the system are negligible and thus $\dot{Q} \cong 0$. **4** There is no work interaction.

Analysis We take the *entire heat exchanger* as the system (Fig. 5–37). This is a *control volume* since mass crosses the system boundary during the process. In general, there are several possibilities for selecting the control volume for multiple-stream steady-flow devices, and the proper choice depends on the situation at hand. We observe that there are two fluid streams (and thus two inlets and two exits) but no mixing.

(a) Under the stated assumptions and observations, the mass and energy balances for this steady-flow system can be expressed in the rate form as follows:

$$\text{Mass balance:} \quad \dot{m}_{in} = \dot{m}_{out}$$

for each fluid stream since there is no mixing. Thus,

$$\dot{m}_1 = \dot{m}_2 = \dot{m}_w$$

$$\dot{m}_3 = \dot{m}_4 = \dot{m}_R$$

$$\text{Energy balance:} \quad \underbrace{\dot{E}_{in} - \dot{E}_{out}}_{\text{Rate of net energy transfer by heat, work, and mass}} = \underbrace{\frac{dE_{system}}{dt}}_{\text{Rate of change in internal, kinetic, potential, etc., energies}} \xrightarrow{0 \text{ (steady)}} = 0$$

$$\dot{E}_{in} = \dot{E}_{out}$$

$$\dot{m}_1 h_1 + \dot{m}_3 h_3 = \dot{m}_2 h_2 + \dot{m}_4 h_4 \quad (\text{since } \dot{Q} \cong 0, \dot{W} = 0, ke \cong pe \cong 0)$$

Combining the mass and energy balances and rearranging give

$$\dot{m}_w (h_1 - h_2) = \dot{m}_R (h_4 - h_3)$$

Now we need to determine the enthalpies at all four states. Water exists as a compressed liquid at both the inlet and the exit since the temperatures at both locations are below the saturation temperature of water at 300 kPa (133.52°C). Approximating the compressed liquid as a saturated liquid at the given temperatures, we have

$$\begin{aligned} h_1 &\cong h_{f@15^\circ\text{C}} = 62.982 \text{ kJ/kg} \\ h_2 &\cong h_{f@25^\circ\text{C}} = 104.83 \text{ kJ/kg} \end{aligned} \quad (\text{Table A-4})$$

The refrigerant enters the condenser as a superheated vapor and leaves as a compressed liquid at 35°C. From refrigerant-134a tables,

$$\left. \begin{array}{l} P_3 = 1 \text{ MPa} \\ T_3 = 70^\circ\text{C} \end{array} \right\} h_3 = 303.85 \text{ kJ/kg} \quad (\text{Table A-13})$$

$$\left. \begin{array}{l} P_4 = 1 \text{ MPa} \\ T_4 = 35^\circ\text{C} \end{array} \right\} h_4 \cong h_{f@35^\circ\text{C}} = 100.87 \text{ kJ/kg} \quad (\text{Table A-11})$$

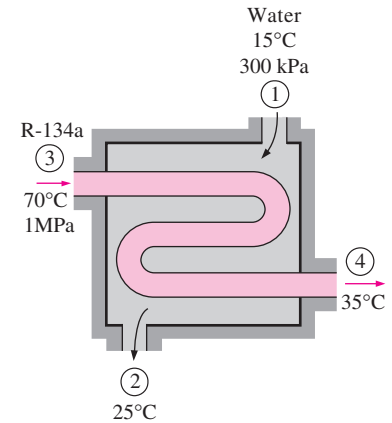

FIGURE 5–37

Schematic for Example 5–10.

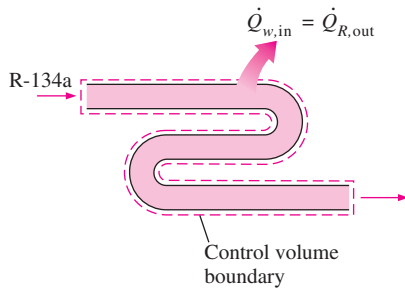

FIGURE 5-38

In a heat exchanger, the heat transfer depends on the choice of the control volume.

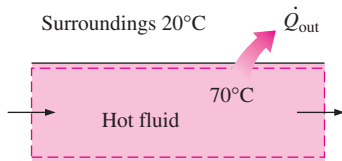

FIGURE 5-39

Heat losses from a hot fluid flowing through an uninsulated pipe or duct to the cooler environment may be very significant.

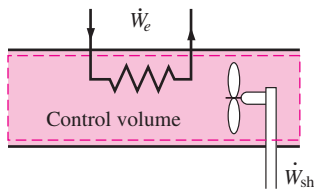

FIGURE 5-40

Pipe or duct flow may involve more than one form of work at the same time.

Substituting, we find

$$\dot{m}_w(62.982 - 104.83) \text{ kJ/kg} = (6 \text{ kg/min})[(100.87 - 303.85) \text{ kJ/kg}]$$

$$\dot{m}_w = \mathbf{29.1 \text{ kg/min}}$$

(b) To determine the heat transfer from the refrigerant to the water, we have to choose a control volume whose boundary lies on the path of heat transfer. We can choose the volume occupied by either fluid as our control volume. For no particular reason, we choose the volume occupied by the water. All the assumptions stated earlier apply, except that the heat transfer is no longer zero. Then assuming heat to be transferred to water, the energy balance for this single-stream steady-flow system reduces to

$$\underbrace{\dot{E}_{\text{in}} - \dot{E}_{\text{out}}}_{\text{Rate of net energy transfer by heat, work, and mass}} = \underbrace{\frac{dE_{\text{system}}/dt}_{\text{Rate of change in internal, kinetic, potential, etc., energies}}}_{0 \text{ (steady)}} = 0$$

$$\dot{E}_{\text{in}} = \dot{E}_{\text{out}}$$

$$\dot{Q}_{w,\text{in}} + \dot{m}_w h_1 = \dot{m}_w h_2$$

Rearranging and substituting,

$$\dot{Q}_{w,\text{in}} = \dot{m}_w(h_2 - h_1) = (29.1 \text{ kg/min})[(104.83 - 62.982) \text{ kJ/kg}]$$

$$= \mathbf{1218 \text{ kJ/min}}$$

Discussion Had we chosen the volume occupied by the refrigerant as the control volume (Fig. 5-38), we would have obtained the same result for $\dot{Q}_{R,\text{out}}$ since the heat gained by the water is equal to the heat lost by the refrigerant.

5 Pipe and Duct Flow

The transport of liquids or gases in pipes and ducts is of great importance in many engineering applications. Flow through a pipe or a duct usually satisfies the steady-flow conditions and thus can be analyzed as a steady-flow process. This, of course, excludes the transient start-up and shut-down periods. The control volume can be selected to coincide with the interior surfaces of the portion of the pipe or the duct that we are interested in analyzing.

Under normal operating conditions, the amount of heat gained or lost by the fluid may be very significant, particularly if the pipe or duct is long (Fig. 5-39). Sometimes heat transfer is desirable and is the sole purpose of the flow. Water flow through the pipes in the furnace of a power plant, the flow of refrigerant in a freezer, and the flow in heat exchangers are some examples of this case. At other times, heat transfer is undesirable, and the pipes or ducts are insulated to prevent any heat loss or gain, particularly when the temperature difference between the flowing fluid and the surroundings is large. Heat transfer in this case is negligible.

If the control volume involves a heating section (electric wires), a fan, or a pump (shaft), the work interactions should be considered (Fig. 5-40). Of these, fan work is usually small and often neglected in energy analysis.

The velocities involved in pipe and duct flow are relatively low, and the kinetic energy changes are usually insignificant. This is particularly true when the pipe or duct diameter is constant and the heating effects are negligible. Kinetic energy changes may be significant, however, for gas flow in ducts with variable cross-sectional areas especially when the compressibility effects are significant. The potential energy term may also be significant when the fluid undergoes a considerable elevation change as it flows in a pipe or duct.

EXAMPLE 5–11 Electric Heating of Air in a House

The electric heating systems used in many houses consist of a simple duct with resistance heaters. Air is heated as it flows over resistance wires. Consider a 15-kW electric heating system. Air enters the heating section at 100 kPa and 17°C with a volume flow rate of 150 m³/min. If heat is lost from the air in the duct to the surroundings at a rate of 200 W, determine the exit temperature of air.

Solution The electric heating system of a house is considered. For specified electric power consumption and air flow rate, the air exit temperature is to be determined.

Assumptions 1 This is a steady-flow process since there is no change with time at any point and thus $\Delta m_{CV} = 0$ and $\Delta E_{CV} = 0$. 2 Air is an ideal gas since it is at a high temperature and low pressure relative to its critical-point values. 3 The kinetic and potential energy changes are negligible, $\Delta ke \cong \Delta pe \cong 0$. 4 Constant specific heats at room temperature can be used for air.

Analysis We take the *heating section portion of the duct* as the system (Fig. 5–41). This is a *control volume* since mass crosses the system boundary during the process. We observe that there is only one inlet and one exit and thus $\dot{m}_1 = \dot{m}_2 = \dot{m}$. Also, heat is lost from the system and electrical work is supplied to the system.

At temperatures encountered in heating and air-conditioning applications, Δh can be replaced by $c_p \Delta T$ where $c_p = 1.005 \text{ kJ/kg} \cdot ^\circ\text{C}$ —the value at room temperature—with negligible error (Fig. 5–42). Then the energy balance for this steady-flow system can be expressed in the rate form as

$$\underbrace{\dot{E}_{in} - \dot{E}_{out}}_{\text{Rate of net energy transfer by heat, work, and mass}} = \underbrace{\frac{dE_{system}/dt}{\text{Rate of change in internal, kinetic, potential, etc., energies}}}_{0 \text{ (steady)}} = 0$$

$$\dot{E}_{in} = \dot{E}_{out}$$

$$\dot{W}_{e,in} + \dot{m}h_1 = \dot{Q}_{out} + \dot{m}h_2 \quad (\text{since } \Delta ke \cong \Delta pe \cong 0)$$

$$\dot{W}_{e,in} - \dot{Q}_{out} = \dot{m}c_p(T_2 - T_1)$$

From the ideal-gas relation, the specific volume of air at the inlet of the duct is

$$v_1 = \frac{RT_1}{P_1} = \frac{(0.287 \text{ kPa} \cdot \text{m}^3/\text{kg} \cdot \text{K})(290 \text{ K})}{100 \text{ kPa}} = 0.832 \text{ m}^3/\text{kg}$$

The mass flow rate of the air through the duct is determined from

$$\dot{m} = \frac{\dot{V}_1}{v_1} = \frac{150 \text{ m}^3/\text{min}}{0.832 \text{ m}^3/\text{kg}} \left(\frac{1 \text{ min}}{60 \text{ s}} \right) = 3.0 \text{ kg/s}$$

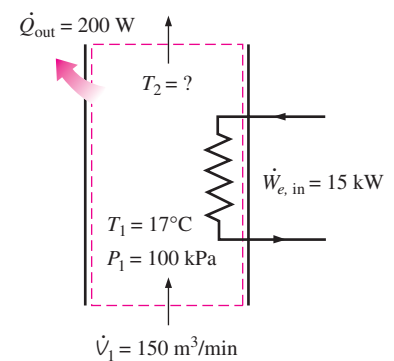

FIGURE 5–41 Schematic for Example 5–11.

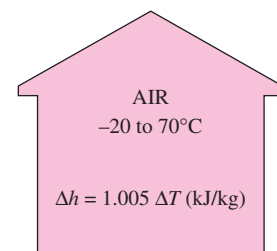

FIGURE 5–42

The error involved in $\Delta h = c_p \Delta T$, where $c_p = 1.005 \text{ kJ/kg} \cdot ^\circ\text{C}$, is less than 0.5 percent for air in the temperature range -20 to 70°C .

Substituting the known quantities, the exit temperature of the air is determined to be

$$(15 \text{ kJ/s}) - (0.2 \text{ kJ/s}) = (3 \text{ kg/s})(1.005 \text{ kJ/kg} \cdot ^\circ\text{C})(T_2 - 17)^\circ\text{C}$$

$$T_2 = \mathbf{21.9^\circ\text{C}}$$

Discussion Note that heat loss from the duct reduces the exit temperature of air.



INTERACTIVE TUTORIAL

SEE TUTORIAL CH. 5, SEC. 5 ON THE DVD.

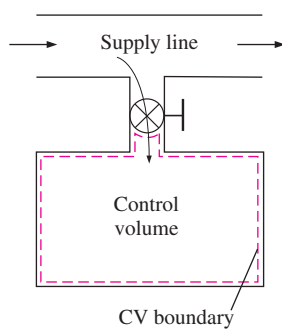

FIGURE 5–43

Charging of a rigid tank from a supply line is an unsteady-flow process since it involves changes within the control volume.

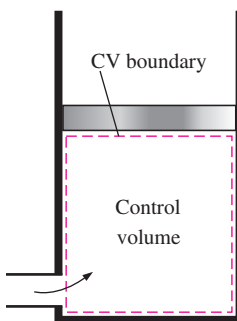

FIGURE 5–44

The shape and size of a control volume may change during an unsteady-flow process.

5–5 ■ ENERGY ANALYSIS OF UNSTEADY-FLOW PROCESSES

During a steady-flow process, no changes occur within the control volume; thus, one does not need to be concerned about what is going on within the boundaries. Not having to worry about any changes within the control volume with time greatly simplifies the analysis.

Many processes of interest, however, involve *changes* within the control volume with time. Such processes are called *unsteady-flow*, or *transient-flow*, processes. The steady-flow relations developed earlier are obviously not applicable to these processes. When an unsteady-flow process is analyzed, it is important to keep track of the mass and energy contents of the control volume as well as the energy interactions across the boundary.

Some familiar unsteady-flow processes are the charging of rigid vessels from supply lines (Fig. 5–43), discharging a fluid from a pressurized vessel, driving a gas turbine with pressurized air stored in a large container, inflating tires or balloons, and even cooking with an ordinary pressure cooker.

Unlike steady-flow processes, unsteady-flow processes start and end over some finite time period instead of continuing indefinitely. Therefore in this section, we deal with changes that occur over some time interval Δt instead of with the rate of changes (changes per unit time). An unsteady-flow system, in some respects, is similar to a closed system, except that the mass within the system boundaries does not remain constant during a process.

Another difference between steady- and unsteady-flow systems is that steady-flow systems are fixed in space, size, and shape. Unsteady-flow systems, however, are not (Fig. 5–44). They are usually stationary; that is, they are fixed in space, but they may involve moving boundaries and thus boundary work.

The *mass balance* for any system undergoing any process can be expressed as (see Sec. 5–1)

$$m_{\text{in}} - m_{\text{out}} = \Delta m_{\text{system}} \quad (\text{kg}) \quad (5-42)$$

where $\Delta m_{\text{system}} = m_{\text{final}} - m_{\text{initial}}$ is the change in the mass of the system. For control volumes, it can also be expressed more explicitly as

$$m_i - m_e = (m_2 - m_1)_{\text{CV}} \quad (5-43)$$

where i = inlet, e = exit, 1 = initial state, and 2 = final state of the control volume. Often one or more terms in the equation above are zero. For exam-

ple, $m_i = 0$ if no mass enters the control volume during the process, $m_e = 0$ if no mass leaves, and $m_1 = 0$ if the control volume is initially evacuated.

The energy content of a control volume changes with time during an unsteady-flow process. The magnitude of change depends on the amount of energy transfer across the system boundaries as heat and work as well as on the amount of energy transported into and out of the control volume by mass during the process. When analyzing an unsteady-flow process, we must keep track of the energy content of the control volume as well as the energies of the incoming and outgoing flow streams.

The general energy balance was given earlier as

$$\text{Energy balance:} \quad \underbrace{E_{\text{in}} - E_{\text{out}}}_{\substack{\text{Net energy transfer} \\ \text{by heat, work, and mass}}} = \underbrace{\Delta E_{\text{system}}}_{\substack{\text{Change in internal, kinetic,} \\ \text{potential, etc., energies}}} \quad (\text{kJ}) \quad (5-44)$$

The general unsteady-flow process, in general, is difficult to analyze because the properties of the mass at the inlets and exits may change during a process. Most unsteady-flow processes, however, can be represented reasonably well by the **uniform-flow process**, which involves the following idealization: *The fluid flow at any inlet or exit is uniform and steady, and thus the fluid properties do not change with time or position over the cross section of an inlet or exit. If they do, they are averaged and treated as constants for the entire process.*

Note that unlike the steady-flow systems, the state of an unsteady-flow system may change with time, and that the state of the mass leaving the control volume at any instant is the same as the state of the mass in the control volume at that instant. The initial and final properties of the control volume can be determined from the knowledge of the initial and final states, which are completely specified by two independent intensive properties for simple compressible systems.

Then the energy balance for a uniform-flow system can be expressed explicitly as

$$\left(Q_{\text{in}} + W_{\text{in}} + \sum_{\text{in}} m\theta \right) - \left(Q_{\text{out}} + W_{\text{out}} + \sum_{\text{out}} m\theta \right) = (m_2e_2 - m_1e_1)_{\text{system}} \quad (5-45)$$

where $\theta = h + ke + pe$ is the energy of a fluid stream at any inlet or exit per unit mass, and $e = u + ke + pe$ is the energy of the nonflowing fluid within the control volume per unit mass. When the kinetic and potential energy changes associated with the control volume and fluid streams are negligible, as is usually the case, the energy balance above simplifies to

$$Q - W = \sum_{\text{out}} mh - \sum_{\text{in}} mh + (m_2u_2 - m_1u_1)_{\text{system}} \quad (5-46)$$

where $Q = Q_{\text{net,in}} = Q_{\text{in}} - Q_{\text{out}}$ is the net heat input and $W = W_{\text{net,out}} = W_{\text{out}} - W_{\text{in}}$ is the net work output. Note that if no mass enters or leaves the control volume during a process ($m_i = m_e = 0$, and $m_1 = m_2 = m$), this equation reduces to the energy balance relation for closed systems (Fig. 5-45). Also note that an unsteady-flow system may involve boundary work as well as electrical and shaft work (Fig. 5-46).

Although both the steady-flow and uniform-flow processes are somewhat idealized, many actual processes can be approximated reasonably well by

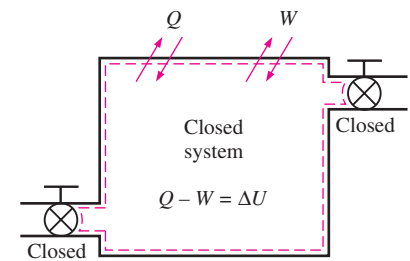

FIGURE 5-45

The energy equation of a uniform-flow system reduces to that of a closed system when all the inlets and exits are closed.

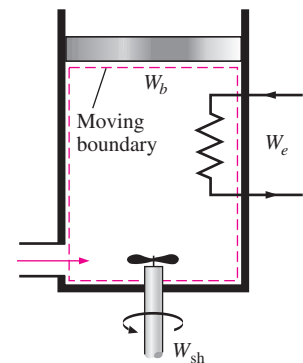

FIGURE 5-46

A uniform-flow system may involve electrical, shaft, and boundary work all at once.

one of these with satisfactory results. The degree of satisfaction depends on the desired accuracy and the degree of validity of the assumptions made.

EXAMPLE 5–12 Charging of a Rigid Tank by Steam

A rigid, insulated tank that is initially evacuated is connected through a valve to a supply line that carries steam at 1 MPa and 300°C. Now the valve is opened, and steam is allowed to flow slowly into the tank until the pressure reaches 1 MPa, at which point the valve is closed. Determine the final temperature of the steam in the tank.

Solution A valve connecting an initially evacuated tank to a steam line is opened, and steam flows in until the pressure inside rises to the line level. The final temperature in the tank is to be determined.

Assumptions **1** This process can be analyzed as a *uniform-flow process* since the properties of the steam entering the control volume remain constant during the entire process. **2** The kinetic and potential energies of the streams are negligible, $ke \cong pe \cong 0$. **3** The tank is stationary and thus its kinetic and potential energy changes are zero; that is, $\Delta KE = \Delta PE = 0$ and $\Delta E_{\text{system}} = \Delta U_{\text{system}}$. **4** There are no boundary, electrical, or shaft work interactions involved. **5** The tank is well insulated and thus there is no heat transfer.

Analysis We take the *tank* as the system (Fig. 5–47). This is a *control volume* since mass crosses the system boundary during the process. We observe that this is an unsteady-flow process since changes occur within the control volume. The control volume is initially evacuated and thus $m_1 = 0$ and $m_1 u_1 = 0$. Also, there is one inlet and no exits for mass flow.

Noting that microscopic energies of flowing and nonflowing fluids are represented by enthalpy h and internal energy u , respectively, the mass and energy balances for this uniform-flow system can be expressed as

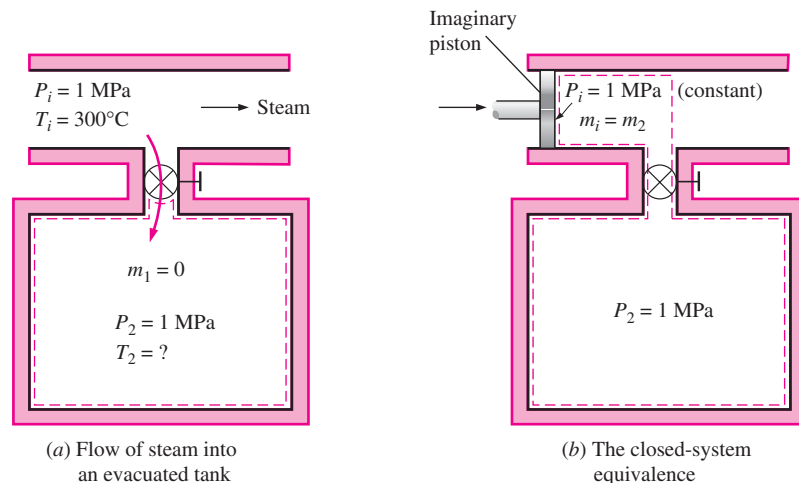

FIGURE 5–47

Schematic for Example 5–12.

$$\text{Mass balance: } m_{\text{in}} - m_{\text{out}} = \Delta m_{\text{system}} \rightarrow m_i = m_2 - \overset{0}{m_1} = m_2$$

$$\text{Energy balance: } \underbrace{E_{\text{in}} - E_{\text{out}}}_{\substack{\text{Net energy transfer} \\ \text{by heat, work, and mass}}} = \underbrace{\Delta E_{\text{system}}}_{\substack{\text{Change in internal, kinetic,} \\ \text{potential, etc., energies}}}$$

$$m_i h_i = m_2 u_2 \quad (\text{since } W = Q = 0, \text{ ke} \cong \text{pe} \cong 0, m_1 = 0)$$

Combining the mass and energy balances gives

$$u_2 = h_i$$

That is, the final internal energy of the steam in the tank is equal to the enthalpy of the steam entering the tank. The enthalpy of the steam at the inlet state is

$$\left. \begin{array}{l} P_i = 1 \text{ MPa} \\ T_i = 300^\circ\text{C} \end{array} \right\} h_i = 3051.6 \text{ kJ/kg} \quad (\text{Table A-6})$$

which is equal to u_2 . Since we now know two properties at the final state, it is fixed and the temperature at this state is determined from the same table to be

$$\left. \begin{array}{l} P_2 = 1 \text{ MPa} \\ u_2 = 3051.6 \text{ kJ/kg} \end{array} \right\} T_2 = 456.1^\circ\text{C}$$

Discussion Note that the temperature of the steam in the tank has increased by 156.1°C . This result may be surprising at first, and you may be wondering where the energy to raise the temperature of the steam came from. The answer lies in the enthalpy term $h = u + Pv$. Part of the energy represented by enthalpy is the flow energy Pv , and this flow energy is converted to sensible internal energy once the flow ceases to exist in the control volume, and it shows up as an increase in temperature (Fig. 5–48).

Alternative solution This problem can also be solved by considering the region within the tank and the mass that is destined to enter the tank as a closed system, as shown in Fig. 5–47*b*. Since no mass crosses the boundaries, viewing this as a closed system is appropriate.

During the process, the steam upstream (the imaginary piston) will push the enclosed steam in the supply line into the tank at a constant pressure of 1 MPa. Then the boundary work done during this process is

$$W_{b,\text{in}} = - \int_1^2 P_i dV = -P_i(V_2 - V_1) = -P_i[V_{\text{tank}} - (V_{\text{tank}} + V_i)] = P_i V_i$$

where V_i is the volume occupied by the steam before it enters the tank and P_i is the pressure at the moving boundary (the imaginary piston face). The energy balance for the closed system gives

$$\underbrace{E_{\text{in}} - E_{\text{out}}}_{\substack{\text{Net energy transfer} \\ \text{by heat, work, and mass}}} = \underbrace{\Delta E_{\text{system}}}_{\substack{\text{Change in internal, kinetic,} \\ \text{potential, etc., energies}}}$$

$$W_{b,\text{in}} = \Delta U$$

$$m_i P_i V_i = m_2 u_2 - m_i u_i$$

$$u_2 = u_i + P_i V_i = h_i$$

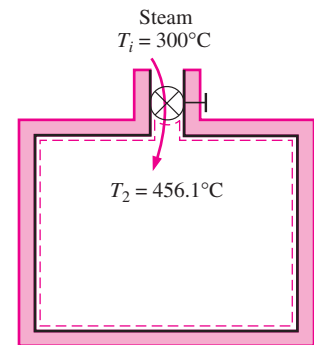

FIGURE 5–48

The temperature of steam rises from 300 to 456.1°C as it enters a tank as a result of flow energy being converted to internal energy.

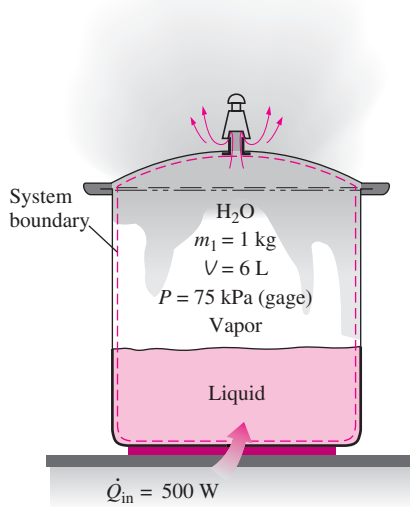

FIGURE 5-49
Schematic for Example 5-13.

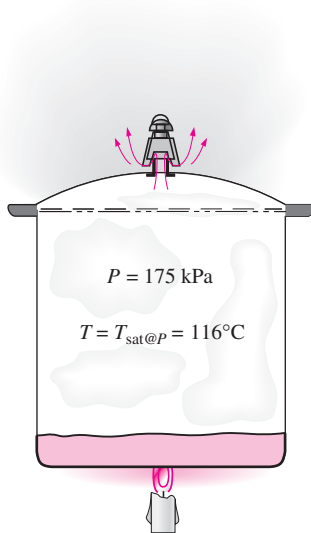

FIGURE 5-50
As long as there is liquid in a pressure cooker, the saturation conditions exist and the temperature remains constant at the saturation temperature.

since the initial state of the system is simply the line conditions of the steam. This result is identical to the one obtained with the uniform-flow analysis. Once again, the temperature rise is caused by the so-called flow energy or flow work, which is the energy required to move the fluid during flow.

EXAMPLE 5-13 Cooking with a Pressure Cooker

A pressure cooker is a pot that cooks food much faster than ordinary pots by maintaining a higher pressure and temperature during cooking. The pressure inside the pot is controlled by a pressure regulator (the petcock) that keeps the pressure at a constant level by periodically allowing some steam to escape, thus preventing any excess pressure buildup.

Pressure cookers, in general, maintain a gage pressure of 2 atm (or 3 atm absolute) inside. Therefore, pressure cookers cook at a temperature of about 133°C (or 271°F) instead of 100°C (or 212°F), cutting the cooking time by as much as 70 percent while minimizing the loss of nutrients. The newer pressure cookers use a spring valve with several pressure settings rather than a weight on the cover.

A certain pressure cooker has a volume of 6 L and an operating pressure of 75 kPa gage. Initially, it contains 1 kg of water. Heat is supplied to the pressure cooker at a rate of 500 W for 30 min after the operating pressure is reached. Assuming an atmospheric pressure of 100 kPa, determine (a) the temperature at which cooking takes place and (b) the amount of water left in the pressure cooker at the end of the process.

Solution Heat is transferred to a pressure cooker at a specified rate for a specified time period. The cooking temperature and the water remaining in the cooker are to be determined.

Assumptions **1** This process can be analyzed as a *uniform-flow process* since the properties of the steam leaving the control volume remain constant during the entire cooking process. **2** The kinetic and potential energies of the streams are negligible, $ke \cong pe \cong 0$. **3** The pressure cooker is stationary and thus its kinetic and potential energy changes are zero; that is, $\Delta KE = \Delta PE = 0$ and $\Delta E_{\text{system}} = \Delta U_{\text{system}}$. **4** The pressure (and thus temperature) in the pressure cooker remains constant. **5** Steam leaves as a saturated vapor at the cooker pressure. **6** There are no boundary, electrical, or shaft work interactions involved. **7** Heat is transferred to the cooker at a constant rate.

Analysis We take the *pressure cooker* as the system (Fig. 5-49). This is a *control volume* since mass crosses the system boundary during the process. We observe that this is an unsteady-flow process since changes occur within the control volume. Also, there is one exit and no inlets for mass flow.

(a) The absolute pressure within the cooker is

$$P_{\text{abs}} = P_{\text{gage}} + P_{\text{atm}} = 75 + 100 = 175 \text{ kPa}$$

Since saturation conditions exist in the cooker at all times (Fig. 5-50), the cooking temperature must be the saturation temperature corresponding to this pressure. From Table A-5, it is

$$T = T_{\text{sat @ 175 kPa}} = \mathbf{116.04^\circ\text{C}}$$

which is about 16°C higher than the ordinary cooking temperature.

(b) Noting that the microscopic energies of flowing and nonflowing fluids are represented by enthalpy h and internal energy u , respectively, the mass and energy balances for this uniform-flow system can be expressed as

Mass balance:

$$m_{\text{in}} - m_{\text{out}} = \Delta m_{\text{system}} \rightarrow -m_e = (m_2 - m_1)_{\text{CV}} \quad \text{or} \quad m_e = (m_1 - m_2)_{\text{CV}}$$

Energy balance:

$$\underbrace{E_{\text{in}} - E_{\text{out}}}_{\substack{\text{Net energy transfer} \\ \text{by heat, work, and mass}}} = \underbrace{\Delta E_{\text{system}}}_{\substack{\text{Change in internal, kinetic,} \\ \text{potential, etc., energies}}}$$

$$Q_{\text{in}} - m_e h_e = (m_2 u_2 - m_1 u_1)_{\text{CV}} \quad (\text{since } W = 0, \text{ ke} \cong \text{pe} \cong 0)$$

Combining the mass and energy balances gives

$$Q_{\text{in}} = (m_1 - m_2)h_e + (m_2 u_2 - m_1 u_1)_{\text{CV}}$$

The amount of heat transfer during this process is found from

$$Q_{\text{in}} = \dot{Q}_{\text{in}} \Delta t = (0.5 \text{ kJ/s})(30 \times 60 \text{ s}) = 900 \text{ kJ}$$

Steam leaves the pressure cooker as saturated vapor at 175 kPa at all times (Fig. 5–51). Thus,

$$h_e = h_{g @ 175 \text{ kPa}} = 2700.2 \text{ kJ/kg}$$

The initial internal energy is found after the quality is determined:

$$v_1 = \frac{V}{m_1} = \frac{0.006 \text{ m}^3}{1 \text{ kg}} = 0.006 \text{ m}^3/\text{kg}$$

$$x_1 = \frac{v_1 - v_f}{v_{fg}} = \frac{0.006 - 0.001}{1.004 - 0.001} = 0.00499$$

Thus,

$$u_1 = u_f + x_1 u_{fg} = 486.82 + (0.00499)(2037.7) \text{ kJ/kg} = 497 \text{ kJ/kg}$$

and

$$U_1 = m_1 u_1 = (1 \text{ kg})(497 \text{ kJ/kg}) = 497 \text{ kJ}$$

The mass of the system at the final state is $m_2 = V/v_2$. Substituting this into the energy equation yields

$$Q_{\text{in}} = \left(m_1 - \frac{V}{v_2} \right) h_e + \left(\frac{V}{v_2} u_2 - m_1 u_1 \right)$$

There are two unknowns in this equation, u_2 and v_2 . Thus we need to relate them to a single unknown before we can determine these unknowns. Assuming there is still some liquid water left in the cooker at the final state (i.e., saturation conditions exist), v_2 and u_2 can be expressed as

$$v_2 = v_f + x_2 v_{fg} = 0.001 + x_2(1.004 - 0.001) \text{ m}^3/\text{kg}$$

$$u_2 = u_f + x_2 u_{fg} = 486.82 + x_2(2037.7) \text{ kJ/kg}$$

Recall that during a boiling process at constant pressure, the properties of each phase remain constant (only the amounts change). When these expressions are substituted into the above energy equation, x_2 becomes the only unknown, and it is determined to be

$$x_2 = 0.009$$

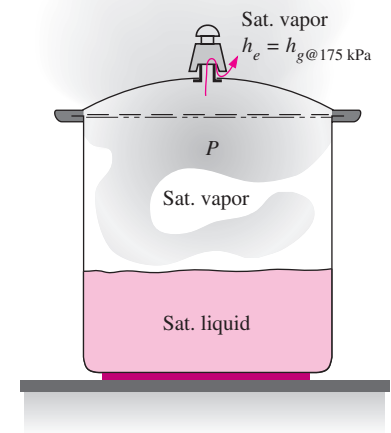

FIGURE 5–51

In a pressure cooker, the enthalpy of the exiting steam is $h_{g @ 175 \text{ kPa}}$ (enthalpy of the saturated vapor at the given pressure).

Thus,

$$v_2 = 0.001 + (0.009)(1.004 - 0.001) \text{ m}^3/\text{kg} = 0.010 \text{ m}^3/\text{kg}$$

and

$$m_2 = \frac{V}{v_2} = \frac{0.006 \text{ m}^3}{0.01 \text{ m}^3/\text{kg}} = \mathbf{0.6 \text{ kg}}$$

Therefore, after 30 min there is 0.6 kg water (liquid + vapor) left in the pressure cooker.

Discussion Note that almost half of the water in the pressure cooker has evaporated during cooking.

TOPIC OF SPECIAL INTEREST*

General Energy Equation

One of the most fundamental laws in nature is the **first law of thermodynamics**, also known as the **conservation of energy principle**, which provides a sound basis for studying the relationships among the various forms of energy and energy interactions. It states that *energy can be neither created nor destroyed during a process; it can only change forms*.

The energy content of a fixed quantity of mass (a closed system) can be changed by two mechanisms: *heat transfer* Q and *work transfer* W . Then the conservation of energy for a fixed quantity of mass can be expressed in rate form as

$$\dot{Q} - \dot{W} = \frac{dE_{\text{sys}}}{dt} \quad \text{or} \quad \dot{Q} - \dot{W} = \frac{d}{dt} \int_{\text{sys}} \rho e \, dV \quad (5-47)$$

where $\dot{Q} = \dot{Q}_{\text{net,in}} = \dot{Q}_{\text{in}} - \dot{Q}_{\text{out}}$ is the net rate of heat transfer to the system (negative, if from the system), $\dot{W} = \dot{W}_{\text{net,out}} = \dot{W}_{\text{out}} - \dot{W}_{\text{in}}$ is the net power output from the system in all forms (negative, if power input) and dE_{sys}/dt is the rate of change of the total energy content of the system. The overdot stands for time rate. For simple compressible systems, total energy consists of internal, kinetic, and potential energies, and it is expressed on a unit-mass basis as

$$e = u + ke + pe = u + \frac{V^2}{2} + gz \quad (5-48)$$

Note that total energy is a property, and its value does not change unless the state of the system changes.

An energy interaction is *heat* if its driving force is a temperature difference, and it is *work* if it is associated with a force acting through a distance, as explained in Chap. 2. A system may involve numerous forms of work, and the total work can be expressed as

$$W_{\text{total}} = W_{\text{shaft}} + W_{\text{pressure}} + W_{\text{viscous}} + W_{\text{other}} \quad (5-49)$$

where W_{shaft} is the work transmitted by a rotating shaft, W_{pressure} is the work done by the pressure forces on the control surface, W_{viscous} is the work done

*This section can be skipped without a loss in continuity.

by the normal and shear components of viscous forces on the control surface, and W_{other} is the work done by other forces such as electric, magnetic, and surface tension, which are insignificant for simple compressible systems and are not considered in this text. We do not consider W_{viscous} either since it is usually small relative to other terms in control volume analysis. But it should be kept in mind that the work done by shear forces as the blades shear through the fluid may need to be considered in a refined analysis of turbomachinery.

Work Done by Pressure Forces

Consider a gas being compressed in the piston–cylinder device shown in Fig. 5–52a. When the piston moves down a differential distance ds under the influence of the pressure force PA , where A is the cross-sectional area of the piston, the boundary work done *on* the system is $\delta W_{\text{boundary}} = PA ds$. Dividing both sides of this relation by the differential time interval dt gives the time rate of boundary work (i.e., *power*),

$$\delta \dot{W}_{\text{pressure}} = \delta \dot{W}_{\text{boundary}} = PA V_{\text{piston}}$$

where $V_{\text{piston}} = ds/dt$ is the piston velocity, which is the velocity of the moving boundary at the piston face.

Now consider a material chunk of fluid (a system) of arbitrary shape, which moves with the flow and is free to deform under the influence of pressure, as shown in Fig. 5–52b. Pressure always acts inward and normal to the surface, and the pressure force acting on a differential area dA is $P dA$. Again noting that work is force times distance and distance traveled per unit time is velocity, the time rate at which work is done by pressure forces on this differential part of the system is

$$\delta \dot{W}_{\text{pressure}} = P dA V_n = P dA (\vec{V} \cdot \vec{n}) \quad (5-50)$$

since the normal component of velocity through the differential area dA is $V_n = V \cos \theta = \vec{V} \cdot \vec{n}$. Note that \vec{n} is the outer normal of dA , and thus the quantity $\vec{V} \cdot \vec{n}$ is positive for expansion and negative for compression. The total rate of work done by pressure forces is obtained by integrating $\delta \dot{W}_{\text{pressure}}$ over the entire surface A ,

$$\dot{W}_{\text{pressure,net out}} = \int_A P (\vec{V} \cdot \vec{n}) dA = \int_A \frac{P}{\rho} \rho (\vec{V} \cdot \vec{n}) dA \quad (5-51)$$

In light of these discussions, the net power transfer can be expressed as

$$\dot{W}_{\text{net,out}} = \dot{W}_{\text{shaft,net out}} + \dot{W}_{\text{pressure,net out}} = \dot{W}_{\text{shaft,net out}} + \int_A P (\vec{V} \cdot \vec{n}) dA \quad (5-52)$$

Then the rate form of the conservation of energy relation for a closed system becomes

$$\dot{Q}_{\text{net,in}} - \dot{W}_{\text{shaft,net out}} - \dot{W}_{\text{pressure,net out}} = \frac{dE_{\text{sys}}}{dt} \quad (5-53)$$

To obtain a relation for the conservation of energy for a *control volume*, we apply the Reynolds transport theorem by replacing the extensive property B with total energy E , and its associated intensive property b with total

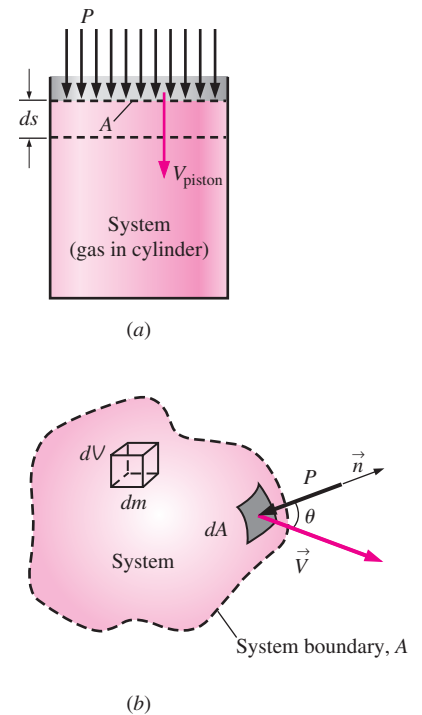

FIGURE 5-52

The pressure force acting on (a) the moving boundary of a system in a piston–cylinder device, and (b) the differential surface area of a system of arbitrary shape.

$$\frac{dB_{\text{sys}}}{dt} = \frac{d}{dt} \int_{\text{CV}} b\rho dV + \int_{\text{CS}} b\rho(\vec{V}_r \cdot \vec{n}) dA$$

$$B = E \quad b = e \quad b = e$$

$$\frac{dE_{\text{sys}}}{dt} = \frac{d}{dt} \int_{\text{CV}} e\rho dV + \int_{\text{CS}} e\rho(\vec{V}_r \cdot \vec{n}) dA$$

FIGURE 5-53

The conservation of energy equation is obtained by replacing an extensive property B in the Reynolds transport theorem by energy E and its associated intensive property b by e (Ref. 3).

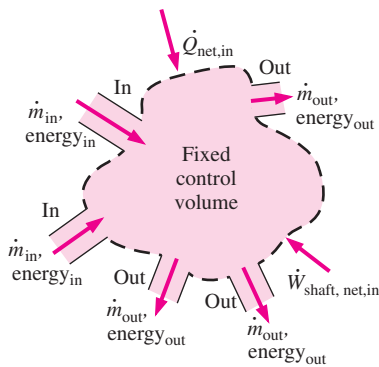
FIGURE 5-54

In a typical engineering problem, the control volume may contain many inlets and outlets; energy flows in at each inlet, and energy flows out at each outlet. Energy also enters the control volume through net heat transfer and net shaft work.

energy per unit mass e , which is $e = u + ke + pe = u + V^2/2 + gz$ (Fig. 5-53). This yields

$$\frac{dE_{\text{sys}}}{dt} = \frac{d}{dt} \int_{\text{CV}} e\rho dV + \int_{\text{CS}} e\rho(\vec{V}_r \cdot \vec{n}) dA \quad (5-54)$$

Substituting the left-hand side of Eq. 5-53 into Eq. 5-54, the general form of the energy equation that applies to fixed, moving, or deforming control volumes becomes

$$\dot{Q}_{\text{net,in}} - \dot{W}_{\text{shaft,net out}} - \dot{W}_{\text{pressure,net out}} = \frac{d}{dt} \int_{\text{CV}} e\rho dV + \int_{\text{CS}} e\rho(\vec{V}_r \cdot \vec{n}) dA \quad (5-55)$$

which can be stated as

$$\left(\begin{array}{l} \text{The net rate of energy} \\ \text{transfer into a CV by} \\ \text{heat and work transfer} \end{array} \right) = \left(\begin{array}{l} \text{The time rate of} \\ \text{change of the energy} \\ \text{content of the CV} \end{array} \right) + \left(\begin{array}{l} \text{The net flow rate of} \\ \text{energy out of the control} \\ \text{surface by mass flow} \end{array} \right)$$

Here $\vec{V}_r = \vec{V} - \vec{V}_{\text{CS}}$ is the fluid velocity relative to the control surface, and the product $\rho(\vec{V}_r \cdot \vec{n}) dA$ represents the mass flow rate through area element dA into or out of the control volume. Again noting that \vec{n} is the outer normal of dA , the quantity $\vec{V}_r \cdot \vec{n}$ and thus mass flow is positive for outflow and negative for inflow.

Substituting the surface integral for the rate of pressure work from Eq. 5-51 into Eq. 5-55 and combining it with the surface integral on the right give

$$\dot{Q}_{\text{net,in}} - \dot{W}_{\text{shaft,net out}} = \frac{d}{dt} \int_{\text{CV}} e\rho dV + \int_{\text{CS}} \left(\frac{P}{\rho} + e \right) \rho(\vec{V}_r \cdot \vec{n}) dA \quad (5-56)$$

This is a very convenient form for the energy equation since pressure work is now combined with the energy of the fluid crossing the control surface and we no longer have to deal with pressure work.

The term $P/\rho = Pv = w_{\text{flow}}$ is the *flow work*, which is the work associated with pushing a fluid into or out of a control volume per unit mass. Note that the fluid velocity at a solid surface is equal to the velocity of the solid surface because of the no-slip condition and is zero for nonmoving surfaces. As a result, the pressure work along the portions of the control surface that coincide with nonmoving solid surfaces is zero. Therefore, pressure work for fixed control volumes can exist only along the imaginary part of the control surface where the fluid enters and leaves the control volume (i.e., inlets and outlets).

This equation is not in a convenient form for solving practical engineering problems because of the integrals, and thus it is desirable to rewrite it in terms of average velocities and mass flow rates through inlets and outlets. If $P/\rho + e$ is nearly uniform across an inlet or outlet, we can simply take it outside the

integral. Noting that $\dot{m} = \int_{A_c} \rho(\vec{V}_r \cdot \vec{n}) dA_c$ is the mass flow rate across an inlet or outlet, the rate of inflow or outflow of energy through the inlet or outlet can be approximated as $\dot{m}(P/\rho + e)$. Then the energy equation becomes (Fig. 5-54)

$$\dot{Q}_{\text{net,in}} - \dot{W}_{\text{shaft,net out}} = \frac{d}{dt} \int_{\text{CV}} e\rho dV + \sum_{\text{out}} \dot{m} \left(\frac{P}{\rho} + e \right) - \sum_{\text{in}} \dot{m} \left(\frac{P}{\rho} + e \right) \quad (5-57)$$

where $e = u + V^2/2 + gz$ is the total energy per unit mass for both the control volume and flow streams. Then,

$$\begin{aligned} \dot{Q}_{\text{net,in}} - \dot{W}_{\text{shaft,net out}} &= \frac{d}{dt} \int_{\text{CV}} e \rho \, dV + \sum_{\text{out}} \dot{m} \left(\frac{P}{\rho} + u + \frac{V^2}{2} + gz \right) \\ &\quad - \sum_{\text{in}} \dot{m} \left(\frac{P}{\rho} + u + \frac{V^2}{2} + gz \right) \end{aligned} \quad (5-58)$$

or

$$\begin{aligned} \dot{Q}_{\text{net,in}} - \dot{W}_{\text{shaft,net out}} &= \frac{d}{dt} \int_{\text{CV}} e \rho \, dV + \sum_{\text{out}} \dot{m} \left(h + \frac{V^2}{2} + gz \right) \\ &\quad - \sum_{\text{in}} \dot{m} \left(h + \frac{V^2}{2} + gz \right) \end{aligned} \quad (5-59)$$

where we used the definition of enthalpy $h = u + Pv = u + P/\rho$. The last two equations are fairly general expressions of conservation of energy, but their use is still limited to uniform flow at inlets and outlets and negligible work due to viscous forces and other effects. Also, the subscript “net,in” stands for “net input,” and thus any heat or work transfer is positive if *to* the system and negative if *from* the system.

SUMMARY

The *conservation of mass principle* states that the net mass transfer to or from a system during a process is equal to the net change (increase or decrease) in the total mass of the system during that process, and is expressed as

$$m_{\text{in}} - m_{\text{out}} = \Delta m_{\text{system}} \quad \text{and} \quad \dot{m}_{\text{in}} - \dot{m}_{\text{out}} = dm_{\text{system}}/dt$$

where $\Delta m_{\text{system}} = m_{\text{final}} - m_{\text{initial}}$ is the change in the mass of the system during the process, \dot{m}_{in} and \dot{m}_{out} are the total rates of mass flow into and out of the system, and dm_{system}/dt is the rate of change of mass within the system boundaries. The relations above are also referred to as the *mass balance* and are applicable to any system undergoing any kind of process.

The amount of mass flowing through a cross section per unit time is called the *mass flow rate*, and is expressed as

$$\dot{m} = \rho VA$$

where ρ = density of fluid, V = average fluid velocity normal to A , and A = cross-sectional area normal to flow direction. The volume of the fluid flowing through a cross section per unit time is called the *volume flow rate* and is expressed as

$$\dot{V} = VA = \dot{m}/\rho$$

The work required to push a unit mass of fluid into or out of a control volume is called *flow work* or *flow energy*, and is expressed as $w_{\text{flow}} = Pv$. In the analysis of control volumes, it is convenient to combine the flow energy and internal

energy into *enthalpy*. Then the total energy of a flowing fluid is expressed as

$$\theta = h + ke + pe = h + \frac{V^2}{2} + gz$$

The total energy transported by a flowing fluid of mass m with uniform properties is $m\theta$. The rate of energy transport by a fluid with a mass flow rate of \dot{m} is $\dot{m}\theta$. When the kinetic and potential energies of a fluid stream are negligible, the amount and rate of energy transport become $E_{\text{mass}} = mh$ and $\dot{E}_{\text{mass}} = \dot{m}h$, respectively.

The *first law of thermodynamics* is essentially an expression of the conservation of energy principle, also called the *energy balance*. The general mass and energy balances for any system undergoing any process can be expressed as

$$\underbrace{E_{\text{in}} - E_{\text{out}}}_{\text{Net energy transfer by heat, work, and mass}} = \underbrace{\Delta E_{\text{system}}}_{\text{Changes in internal, kinetic, potential, etc., energies}}$$

It can also be expressed in the *rate form* as

$$\underbrace{\dot{E}_{\text{in}} - \dot{E}_{\text{out}}}_{\text{Rate of net energy transfer by heat, work, and mass}} = \underbrace{dE_{\text{system}}/dt}_{\text{Rate of change in internal, kinetic, potential, etc., energies}}$$

Thermodynamic processes involving control volumes can be considered in two groups: steady-flow processes and

unsteady-flow processes. During a *steady-flow process*, the fluid flows through the control volume steadily, experiencing no change with time at a fixed position. The mass and energy content of the control volume remain constant during a steady-flow process. Taking heat transfer *to* the system and work done *by* the system to be positive quantities, the conservation of mass and energy equations for steady-flow processes are expressed as

$$\sum_{\text{in}} \dot{m} = \sum_{\text{out}} \dot{m}$$

$$\dot{Q} - \dot{W} = \sum_{\text{out}} \underbrace{\dot{m} \left(h + \frac{V^2}{2} + gz \right)}_{\text{for each exit}} - \sum_{\text{in}} \underbrace{\dot{m} \left(h + \frac{V^2}{2} + gz \right)}_{\text{for each inlet}}$$

These are the most general forms of the equations for steady-flow processes. For single-stream (one-inlet–one-exit) systems such as nozzles, diffusers, turbines, compressors, and pumps, they simplify to

$$\dot{m}_1 = \dot{m}_2 \rightarrow \frac{1}{v_1} V_1 A_1 = \frac{1}{v_2} V_2 A_2$$

$$\dot{Q} - \dot{W} = \dot{m} \left[h_2 - h_1 + \frac{V_2^2 - V_1^2}{2} + g(z_2 - z_1) \right]$$

In these relations, subscripts 1 and 2 denote the inlet and exit states, respectively.

Most unsteady-flow processes can be modeled as a *uniform-flow process*, which requires that the fluid flow at any inlet or exit is uniform and steady, and thus the fluid properties do not change with time or position over the cross section of an inlet or exit. If they do, they are averaged and treated as constants for the entire process. When kinetic and potential energy changes associated with the control volume and the fluid streams are negligible, the mass and energy balance relations for a uniform-flow system are expressed as

$$m_{\text{in}} - m_{\text{out}} = \Delta m_{\text{system}}$$

$$Q - W = \sum_{\text{out}} mh - \sum_{\text{in}} mh + (m_2 u_2 - m_1 u_1)_{\text{system}}$$

where $Q = Q_{\text{net,in}} = Q_{\text{in}} - Q_{\text{out}}$ is the net heat input and $W = W_{\text{net,out}} = W_{\text{out}} - W_{\text{in}}$ is the net work output.

When solving thermodynamic problems, it is recommended that the general form of the energy balance $E_{\text{in}} - E_{\text{out}} = \Delta E_{\text{system}}$ be used for all problems, and simplify it for the particular problem instead of using the specific relations given here for different processes.



REFERENCES AND SUGGESTED READINGS

1. ASHRAE Handbook of Fundamentals. SI version. Atlanta, GA: American Society of Heating, Refrigerating, and Air-Conditioning Engineers, Inc., 1993.
2. ASHRAE Handbook of Refrigeration. SI version. Atlanta, GA: American Society of Heating, Refrigerating, and Air-Conditioning Engineers, Inc., 1994.
3. Y. A. Çengel and J. M. Cimbala, *Fluid Mechanics: Fundamentals and Applications*. New York: McGraw-Hill, 2006.

PROBLEMS*

Conservation of Mass

5–1C Name four physical quantities that are conserved and two quantities that are not conserved during a process.

*Problems designated by a “C” are concept questions, and students are encouraged to answer them all. Problems designated by an “E” are in English units, and the SI users can ignore them. Problems with the  icon are solved using EES, and complete solutions together with parametric studies are included on the enclosed DVD. Problems with the  icon are comprehensive in nature, and are intended to be solved with a computer, preferably using the EES software that accompanies this text.

5–2C Define mass and volume flow rates. How are they related to each other?

5–3C Does the amount of mass entering a control volume have to be equal to the amount of mass leaving during an unsteady-flow process?

5–4C When is the flow through a control volume steady?

5–5C Consider a device with one inlet and one outlet. If the volume flow rates at the inlet and at the outlet are the same, is the flow through this device necessarily steady? Why?

5-6E A garden hose attached with a nozzle is used to fill a 20-gal bucket. The inner diameter of the hose is 1 in and it reduces to 0.5 in at the nozzle exit. If the average velocity in the hose is 8 ft/s, determine (a) the volume and mass flow rates of water through the hose, (b) how long it will take to fill the bucket with water, and (c) the average velocity of water at the nozzle exit.

5-7 Air enters a nozzle steadily at 2.21 kg/m^3 and 40 m/s and leaves at 0.762 kg/m^3 and 180 m/s . If the inlet area of the nozzle is 90 cm^2 , determine (a) the mass flow rate through the nozzle, and (b) the exit area of the nozzle. *Answers: (a) 0.796 kg/s , (b) 58 cm^2*

5-8E A steam pipe is to transport 200 lbm/s of steam at 200 psia and 600°F . Calculate the minimum diameter this pipe can have so that the steam velocity does not exceed 59 ft/s . *Answer: 3.63 ft*

5-9 A pump increases the water pressure from 70 kPa at the inlet to 700 kPa at the outlet. Water enters this pump at 15°C through a 1-cm -diameter opening and exits through a 1.5-cm -diameter opening. Determine the velocity of the water at the inlet and outlet when the mass flow rate through the pump is 0.5 kg/s . Will these velocities change significantly if the inlet temperature is raised to 40°C ?

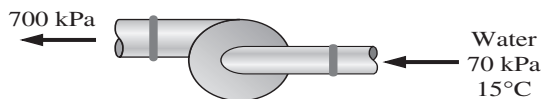

FIGURE P5-9

5-10 A hair dryer is basically a duct of constant diameter in which a few layers of electric resistors are placed. A small fan pulls the air in and forces it through the resistors where it is heated. If the density of air is 1.20 kg/m^3 at the inlet and 1.05 kg/m^3 at the exit, determine the percent increase in the velocity of air as it flows through the dryer.

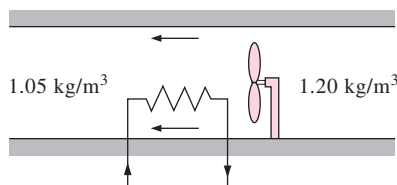

FIGURE P5-10

5-11 A 1-m^3 rigid tank initially contains air whose density is 1.18 kg/m^3 . The tank is connected to a high-pressure supply line through a valve. The valve is opened, and air is allowed to enter the tank until the density in the tank rises to 7.20 kg/m^3 . Determine the mass of air that has entered the tank. *Answer: 6.02 kg*

5-12 A smoking lounge is to accommodate 15 heavy smokers. The minimum fresh air requirement for smoking lounges is specified to be 30 L/s per person (ASHRAE, Standard 62, 1989). Determine the minimum required flow rate of fresh air that needs to be supplied to the lounge, and the diameter of the duct if the air velocity is not to exceed 8 m/s .

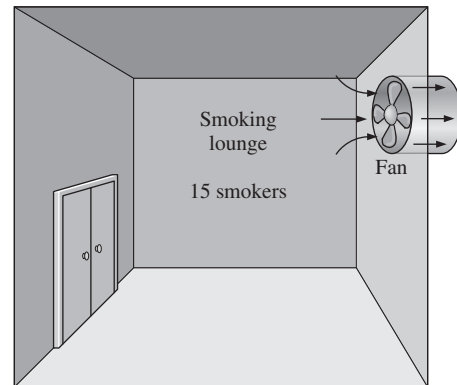

FIGURE P5-12

5-13 The minimum fresh air requirement of a residential building is specified to be 0.35 air change per hour (ASHRAE, Standard 62, 1989). That is, 35 percent of the entire air contained in a residence should be replaced by fresh outdoor air every hour. If the ventilation requirement of a 2.7-m -high, 200-m^2 residence is to be met entirely by a fan, determine the flow capacity in L/min of the fan that needs to be installed. Also determine the diameter of the duct if the air velocity is not to exceed 6 m/s .

5-14 A cyclone separator like that in Fig. P5-14 is used to remove fine solid particles, such as fly ash, that are suspended in a gas stream. In the flue-gas system of an electrical power plant, the weight fraction of fly ash in the exhaust gases is approximately 0.001 . Determine the mass flow rates at the two outlets (flue gas and fly ash) when 10 kg/s of flue gas and ash mixture enters this unit. Also determine the amount of fly ash collected per year.

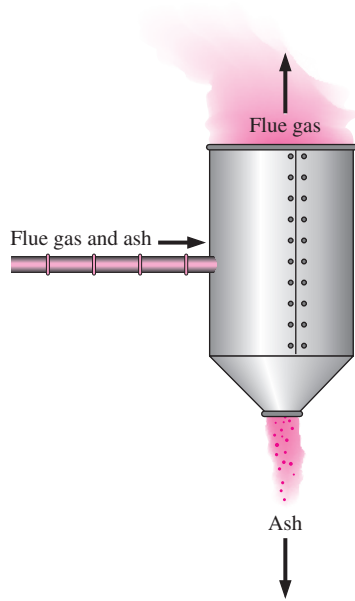

FIGURE P5-14

5-15 Air enters the 1-m^2 inlet of an aircraft engine at 100 kPa and 20°C with a velocity of 180 m/s . Determine the volume flow rate, in m^3/s , at the engine's inlet and the mass flow rate, in kg/s , at the engine's exit.

5-16 A spherical hot-air balloon is initially filled with air at 120 kPa and 35°C with an initial diameter of 3 m . Air enters this balloon at 120 kPa and 35°C with a velocity of 2 m/s through a 1-m diameter opening. How many minutes will it take to inflate this balloon to a 15-m diameter when the pressure and temperature of the air in the balloon remain the same as the air entering the balloon? *Answer: 18.6 min*

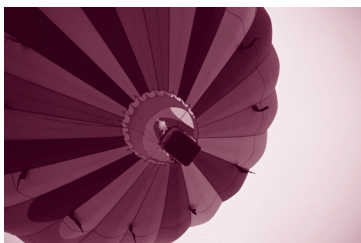

FIGURE P5-16

© Vol. 27/PhotoDisc

5-17 Water enters the constant 130-mm inside-diameter tubes of a boiler at 7 MPa and 65°C , and leaves the tubes at 6 MPa and 450°C with a velocity of 80 m/s . Calculate the velocity of the water at the tube inlet and the inlet volume flow rate.

5-18 Refrigerant-134a enters a 28-cm diameter pipe steadily at 200 kPa and 20°C with a velocity of 5 m/s . The refrigerant gains heat as it flows and leaves the pipe at 180 kPa and 40°C . Determine (a) the volume flow rate of the refrigerant at the inlet, (b) the mass flow rate of the refrigerant, and (c) the velocity and volume flow rate at the exit.

Flow Work and Energy Transfer by Mass

5-19C What are the different mechanisms for transferring energy to or from a control volume?

5-20C What is flow energy? Do fluids at rest possess any flow energy?

5-21C How do the energies of a flowing fluid and a fluid at rest compare? Name the specific forms of energy associated with each case.

5-22E Steam is leaving a pressure cooker whose operating pressure is 30 psia . It is observed that the amount of liquid in the cooker has decreased by 0.4 gal in 45 minutes after the steady operating conditions are established, and the cross-sectional area of the exit opening is 0.15 in^2 . Determine (a) the mass flow rate of the steam and the exit velocity, (b) the total and flow energies of the steam per unit mass, and (c) the rate at which energy is leaving the cooker by steam.

5-23 Air flows steadily in a pipe at 300 kPa , 77°C , and 25 m/s at a rate of 18 kg/min . Determine (a) the diameter of the pipe, (b) the rate of flow energy, (c) the rate of energy transport by mass, and (d) the error involved in part (c) if the kinetic energy is neglected.

5-24E A water pump increases the water pressure from 10 psia to 50 psia . Determine the flow work, in Btu/lbm , required by the pump.

5-25 An air compressor compresses 10 L of air at 120 kPa and 20°C to 1000 kPa and 300°C . Determine the flow work, in kJ/kg , required by the compressor. *Answer: 80.4 kJ/kg*

Steady-Flow Energy Balance: Nozzles and Diffusers

5-26C How is a steady-flow system characterized?

5-27C Can a steady-flow system involve boundary work?

5-28C A diffuser is an adiabatic device that decreases the kinetic energy of the fluid by slowing it down. What happens to this *lost* kinetic energy?

5-29C The kinetic energy of a fluid increases as it is accelerated in an adiabatic nozzle. Where does this energy come from?

5-30C Is heat transfer to or from the fluid desirable as it flows through a nozzle? How will heat transfer affect the fluid velocity at the nozzle exit?

5-31 Air enters an adiabatic nozzle steadily at 300 kPa , 200°C , and 30 m/s and leaves at 100 kPa and 180 m/s . The

inlet area of the nozzle is 80 cm^2 . Determine (a) the mass flow rate through the nozzle, (b) the exit temperature of the air, and (c) the exit area of the nozzle. **Answers:** (a) 0.5304 kg/s , (b) 184.6°C , (c) 38.7 cm^2

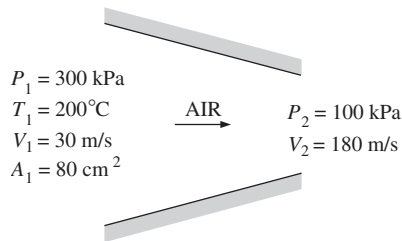



FIGURE P5-31

5-32  Reconsider Prob. 5-31. Using EES (or other) software, investigate the effect of the inlet area on the mass flow rate, exit temperature, and the exit area. Let the inlet area vary from 50 cm^2 to 150 cm^2 . Plot the final results against the inlet area, and discuss the results.

5-33E The stators in a gas turbine are designed to increase the kinetic energy of the gas passing through them adiabatically. Air enters a set of these nozzles at 300 psia and 700°F with a velocity of 80 ft/s and exits at 250 psia and 645°F . Calculate the velocity at the exit of the nozzles.

5-34 The diffuser in a jet engine is designed to decrease the kinetic energy of the air entering the engine compressor without any work or heat interactions. Calculate the velocity at the exit of a diffuser when air at 100 kPa and 20°C enters it with a velocity of 500 m/s and the exit state is 200 kPa and 90°C .



FIGURE P5-34

© Stockbyte/Punchstock

5-35 Steam at 5 MPa and 400°C enters a nozzle steadily with a velocity of 80 m/s , and it leaves at 2 MPa and 300°C . The inlet area of the nozzle is 50 cm^2 , and heat is being lost at a rate of 120 kJ/s . Determine (a) the mass flow rate of the

steam, (b) the exit velocity of the steam, and (c) the exit area of the nozzle.

5-36  Steam at 3 MPa and 400°C enters an adiabatic nozzle steadily with a velocity of 40 m/s and leaves at 2.5 MPa and 300 m/s . Determine (a) the exit temperature and (b) the ratio of the inlet to exit area A_1/A_2 .

5-37 Air at 80 kPa and 127°C enters an adiabatic diffuser steadily at a rate of 6000 kg/h and leaves at 100 kPa . The velocity of the air stream is decreased from 230 to 30 m/s as it passes through the diffuser. Find (a) the exit temperature of the air and (b) the exit area of the diffuser.

5-38E Air at 13 psia and 20°F enters an adiabatic diffuser steadily with a velocity of 600 ft/s and leaves with a low velocity at a pressure of 14.5 psia . The exit area of the diffuser is 5 times the inlet area. Determine (a) the exit temperature and (b) the exit velocity of the air.

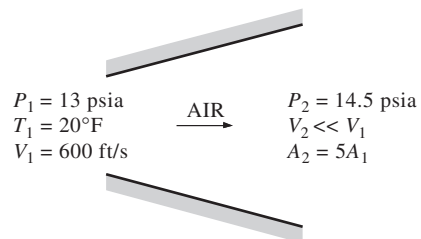



FIGURE P5-38E

5-39 Carbon dioxide enters an adiabatic nozzle steadily at 1 MPa and 500°C with a mass flow rate of 6000 kg/h and leaves at 100 kPa and 450 m/s . The inlet area of the nozzle is 40 cm^2 . Determine (a) the inlet velocity and (b) the exit temperature. **Answers:** (a) 60.8 m/s , (b) 685.8 K

5-40 Refrigerant-134a at 700 kPa and 120°C enters an adiabatic nozzle steadily with a velocity of 20 m/s and leaves at 400 kPa and 30°C . Determine (a) the exit velocity and (b) the ratio of the inlet to exit area A_1/A_2 .

5-41 Nitrogen gas at 60 kPa and 7°C enters an adiabatic diffuser steadily with a velocity of 200 m/s and leaves at 85 kPa and 22°C . Determine (a) the exit velocity of the nitrogen and (b) the ratio of the inlet to exit area A_1/A_2 .

5-42  Reconsider Prob. 5-41. Using EES (or other) software, investigate the effect of the inlet velocity on the exit velocity and the ratio of the inlet-to-exit area. Let the inlet velocity vary from 180 to 260 m/s . Plot the final results against the inlet velocity, and discuss the results.

5-43 Refrigerant-134a enters a diffuser steadily as saturated vapor at 800 kPa with a velocity of 120 m/s , and it leaves at 900 kPa and 40°C . The refrigerant is gaining heat at a rate of

2 kJ/s as it passes through the diffuser. If the exit area is 80 percent greater than the inlet area, determine (a) the exit velocity and (b) the mass flow rate of the refrigerant.

Answers: (a) 60.8 m/s, (b) 1.308 kg/s

5-44 Steam enters a nozzle at 400°C and 800 kPa with a velocity of 10 m/s, and leaves at 300°C and 200 kPa while losing heat at a rate of 25 kW. For an inlet area of 800 cm², determine the velocity and the volume flow rate of the steam at the nozzle exit. Answers: 606 m/s, 2.74 m³/s

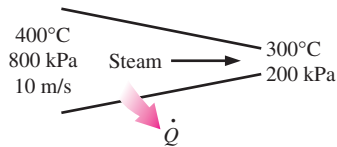

FIGURE P5-44

Turbines and Compressors

5-45C Consider an adiabatic turbine operating steadily. Does the work output of the turbine have to be equal to the decrease in the energy of the steam flowing through it?

5-46C Consider an air compressor operating steadily. How would you compare the volume flow rates of the air at the compressor inlet and exit?

5-47C Will the temperature of air rise as it is compressed by an adiabatic compressor? Why?

5-48C Somebody proposes the following system to cool a house in the summer: Compress the regular outdoor air, let it cool back to the outdoor temperature, pass it through a turbine, and discharge the cold air leaving the turbine into the house. From a thermodynamic point of view, is the proposed system sound?

5-49 Air is expanded from 1000 kPa and 600°C at the inlet of a steady-flow turbine to 100 kPa and 200°C at the outlet. The inlet area and velocity are 0.1 m² and 30 m/s, respectively, and the outlet velocity is 10 m/s. Determine the mass flow rate and outlet area.

5-50E Air enters a gas turbine at 150 psia and 700°F and leaves at 15 psia and 100°F. Determine the inlet and outlet volume flow rates when the mass flow rate through this turbine is 5 lbm/s.

5-51 An adiabatic air compressor compresses 10 L/S of air at 120 kPa and 20°C to 1000 kPa and 300°C. Determine (a) the work required by the compressor, in kJ/kg, and (b) the power required to drive the air compressor, in kW.

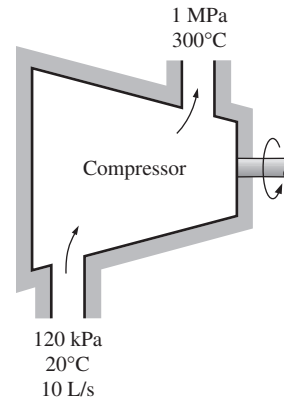

FIGURE P5-51

5-52 Steam flows steadily through an adiabatic turbine. The inlet conditions of the steam are 10 MPa, 450°C, and 80 m/s, and the exit conditions are 10 kPa, 92 percent quality, and 50 m/s. The mass flow rate of the steam is 12 kg/s. Determine (a) the change in kinetic energy, (b) the power output, and (c) the turbine inlet area. Answers: (a) -1.95 kJ/kg, (b) 10.2 MW, (c) 0.00447 m²

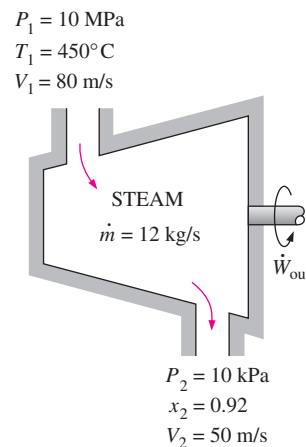



FIGURE P5-52

5-53  Reconsider Prob. 5-52. Using EES (or other) software, investigate the effect of the turbine exit pressure on the power output of the turbine. Let the exit pressure vary from 10 to 200 kPa. Plot the power output against the exit pressure, and discuss the results.

5-54 Steam enters an adiabatic turbine at 10 MPa and 500°C and leaves at 10 kPa with a quality of 90 percent. Neglecting the changes in kinetic and potential energies, determine the mass flow rate required for a power output of 5 MW. Answer: 4.852 kg/s

5-55E Steam flows steadily through a turbine at a rate of 45,000 lbm/h, entering at 1000 psia and 900°F and leaving at

5 psia as saturated vapor. If the power generated by the turbine is 4 MW, determine the rate of heat loss from the steam.

5–56 Steam enters an adiabatic turbine at 8 MPa and 500°C at a rate of 3 kg/s and leaves at 20 kPa. If the power output of the turbine is 2.5 MW, determine the temperature of the steam at the turbine exit. Neglect kinetic energy changes.

Answer: 60.1°C

5–57 Argon gas enters an adiabatic turbine steadily at 900 kPa and 450°C with a velocity of 80 m/s and leaves at 150 kPa with a velocity of 150 m/s. The inlet area of the turbine is 60 cm². If the power output of the turbine is 250 kW, determine the exit temperature of the argon.

5–58 Helium is to be compressed from 120 kPa and 310 K to 700 kPa and 430 K. A heat loss of 20 kJ/kg occurs during the compression process. Neglecting kinetic energy changes, determine the power input required for a mass flow rate of 90 kg/min.

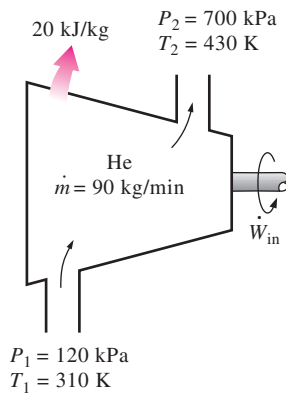

FIGURE P5–58

5–59 Carbon dioxide enters an adiabatic compressor at 100 kPa and 300 K at a rate of 0.5 kg/s and leaves at 600 kPa and 450 K. Neglecting kinetic energy changes, determine (a) the volume flow rate of the carbon dioxide at the compressor inlet and (b) the power input to the compressor.

Answers: (a) 0.28 m³/s, (b) 68.8 kW

5–60 An adiabatic gas turbine expands air at 1000 kPa and 500°C to 100 kPa and 150°C. Air enters the turbine through a 0.2-m² opening with an average velocity of 40 m/s, and exhausts through a 1-m² opening. Determine (a) the mass flow rate of air through the turbine and (b) the power produced by the turbine. *Answers:* (a) 36.1 kg/s, (b) 13.3 MW

5–61 Air is compressed by an adiabatic compressor from 100 kPa and 20°C to 1.8 MPa and 400°C. Air enters the compressor through a 0.15-m² opening with a velocity of 30 m/s. It exits through a 0.08-m² opening. Calculate the mass flow rate of air and the required power input.

5–62E Air is expanded by an adiabatic gas turbine from 500 psia and 800°F to 60 psia and 250°F. If the volume flow

rate at the exit is 50 ft³/s; the inlet area is 0.6 ft²; and the outlet area is 1.2 ft²; determine the power produced by this turbine.

5–63 A portion of the steam passing through a steam turbine is sometimes removed for the purposes of feedwater heating as shown in Fig. P5–63. Consider an adiabatic steam turbine with 12.5 MPa and 550°C steam entering at a rate of 20 kg/s. Steam is bled from this turbine at 1000 kPa and 200°C with a mass flow rate of 1 kg/s. The remaining steam leaves the turbine at 100 kPa and 100°C. Determine the power produced by this turbine. *Answer:* 15,860 kW

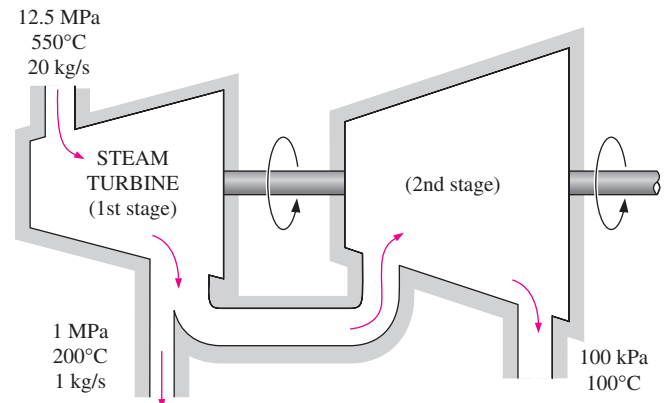

FIGURE P5–63

Throttling Valves

5–64C During a throttling process, the temperature of a fluid drops from 30 to –20°C. Can this process occur adiabatically?

5–65C Would you expect the temperature of air to drop as it undergoes a steady-flow throttling process? Explain.

5–66C Would you expect the temperature of a liquid to change as it is throttled? Explain.

5–67C Someone claims, based on temperature measurements, that the temperature of a fluid rises during a throttling process in a well-insulated valve with negligible friction. How do you evaluate this claim? Does this process violate any thermodynamic laws?

5–68 An adiabatic capillary tube is used in some refrigeration systems to drop the pressure of the refrigerant from the condenser level to the evaporator level. The R-134a enters the capillary tube as a saturated liquid at 50°C, and leaves at –12°C. Determine the quality of the refrigerant at the inlet of the evaporator.

5–69 Saturated liquid-vapor mixture of water, called wet steam, in a steam line at 2000 kPa is throttled to 100 kPa and 120°C. What is the quality in the steam line? *Answer:* 0.957

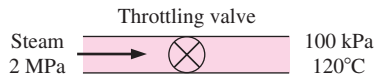



FIGURE P5-69

5-70  Refrigerant-134a at 800 kPa and 25°C is throttled to a temperature of -20°C . Determine the pressure and the internal energy of the refrigerant at the final state. *Answers: 133 kPa, 80.7 kJ/kg*

5-71 A well-insulated valve is used to throttle steam from 8 MPa and 500°C to 6 MPa. Determine the final temperature of the steam. *Answer: 490.1°C*

5-72  Reconsider Prob. 5-71. Using EES (or other) software, investigate the effect of the exit pressure of steam on the exit temperature after throttling. Let the exit pressure vary from 6 to 1 MPa. Plot the exit temperature of steam against the exit pressure, and discuss the results.

5-73E Air at 200 psia and 90°F is throttled to the atmospheric pressure of 14.7 psia. Determine the final temperature of the air.

5-74 Carbon dioxide gas enters a throttling valve at 5 MPa and 100°C and leaves at 100 kPa. Determine the temperature change during this process if CO_2 is assumed to be (a) an ideal gas and (b) a real gas. Real gas properties of CO_2 may be obtained from EES.

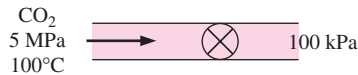

FIGURE P5-74

Mixing Chambers and Heat Exchangers

5-75C When two fluid streams are mixed in a mixing chamber, can the mixture temperature be lower than the temperature of both streams? Explain.

5-76C Consider a steady-flow mixing process. Under what conditions will the energy transported into the control volume by the incoming streams be equal to the energy transported out of it by the outgoing stream?

5-77C Consider a steady-flow heat exchanger involving two different fluid streams. Under what conditions will the amount of heat lost by one fluid be equal to the amount of heat gained by the other?

5-78 A hot-water stream at 80°C enters a mixing chamber with a mass flow rate of 0.5 kg/s where it is mixed with a stream of cold water at 20°C . If it is desired that the mixture leave the chamber at 42°C , determine the mass flow rate of the cold-water stream. Assume all the streams are at a pressure of 250 kPa. *Answer: 0.865 kg/s*

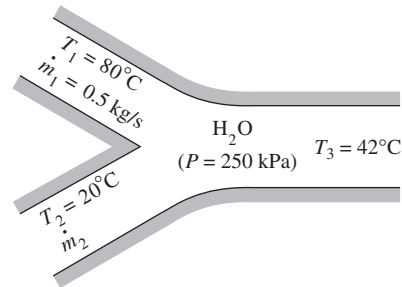



FIGURE P5-78

5-79E Water at 50°F and 50 psia is heated in a chamber by mixing it with saturated water vapor at 50 psia. If both streams enter the mixing chamber at the same mass flow rate, determine the temperature and the quality of the exiting stream. *Answers: 281°F, 0.374*

5-80 A stream of refrigerant-134a at 1 MPa and 12°C is mixed with another stream at 1 MPa and 60°C . If the mass flow rate of the cold stream is twice that of the hot one, determine the temperature and the quality of the exit stream.

5-81  Reconsider Prob. 5-80. Using EES (or other) software, investigate the effect of the mass flow rate of the cold stream of R-134a on the temperature and the quality of the exit stream. Let the ratio of the mass flow rate of the cold stream to that of the hot stream vary from 1 to 4. Plot the mixture temperature and quality against the cold-to-hot mass flow rate ratio, and discuss the results.

5-82 Refrigerant-134a at 700 kPa, 70°C , and 8 kg/min is cooled by water in a condenser until it exists as a saturated liquid at the same pressure. The cooling water enters the condenser at 300 kPa and 15°C and leaves at 25°C at the same pressure. Determine the mass flow rate of the cooling water required to cool the refrigerant. *Answer: 42.0 kg/min*

5-83E  In a steam heating system, air is heated by being passed over some tubes through which steam flows steadily. Steam enters the heat exchanger at 30 psia and 400°F at a rate of 15 lbm/min and leaves at 25 psia and 212°F . Air enters at 14.7 psia and 80°F and leaves at 130°F . Determine the volume flow rate of air at the inlet.

5-84 Steam enters the condenser of a steam power plant at 20 kPa and a quality of 95 percent with a mass flow rate of 20,000 kg/h. It is to be cooled by water from a nearby river by circulating the water through the tubes within the condenser. To prevent thermal pollution, the river water is not allowed to experience a temperature rise above 10°C . If the steam is to leave the condenser as saturated liquid at 20 kPa, determine the mass flow rate of the cooling water required. *Answer: 297.7 kg/s*

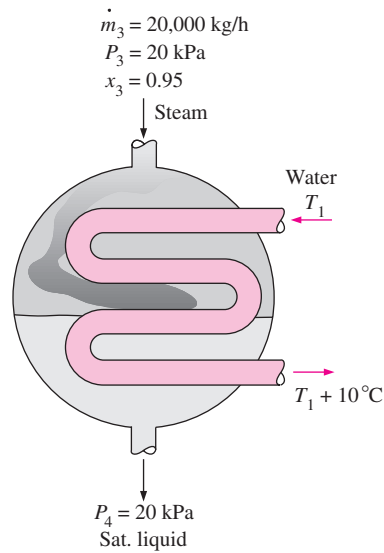



FIGURE P5-84

5-85 A heat exchanger is to cool ethylene glycol ($c_p = 2.56 \text{ kJ/kg} \cdot ^\circ\text{C}$) flowing at a rate of 2 kg/s from 80°C to 40°C by water ($c_p = 4.18 \text{ kJ/kg} \cdot ^\circ\text{C}$) that enters at 20°C and leaves at 55°C . Determine (a) the rate of heat transfer and (b) the mass flow rate of water.

5-86  Reconsider Prob. 5-85. Using EES (or other) software, investigate the effect of the inlet temperature of cooling water on the mass flow rate of water. Let the inlet temperature vary from 10 to 40°C , and assume the exit temperature to remain constant. Plot the mass flow rate of water against the inlet temperature, and discuss the results.

5-87 A thin-walled double-pipe counter-flow heat exchanger is used to cool oil ($c_p = 2.20 \text{ kJ/kg} \cdot ^\circ\text{C}$) from 150 to 40°C at a rate of 2 kg/s by water ($c_p = 4.18 \text{ kJ/kg} \cdot ^\circ\text{C}$) that enters at 22°C at a rate of 1.5 kg/s . Determine the rate of heat transfer in the heat exchanger and the exit temperature of water.

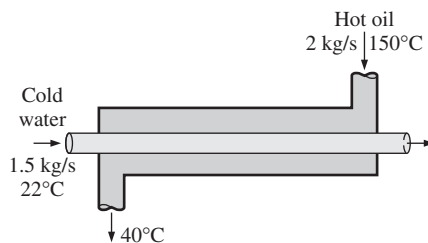

FIGURE P5-87

5-88 Cold water ($c_p = 4.18 \text{ kJ/kg} \cdot ^\circ\text{C}$) leading to a shower enters a thin-walled double-pipe counter-flow heat exchanger

at 15°C at a rate of 0.60 kg/s and is heated to 45°C by hot water ($c_p = 4.19 \text{ kJ/kg} \cdot ^\circ\text{C}$) that enters at 100°C at a rate of 3 kg/s . Determine the rate of heat transfer in the heat exchanger and the exit temperature of the hot water.

5-89 Air ($c_p = 1.005 \text{ kJ/kg} \cdot ^\circ\text{C}$) is to be preheated by hot exhaust gases in a cross-flow heat exchanger before it enters the furnace. Air enters the heat exchanger at 95 kPa and 20°C at a rate of $0.8 \text{ m}^3/\text{s}$. The combustion gases ($c_p = 1.10 \text{ kJ/kg} \cdot ^\circ\text{C}$) enter at 180°C at a rate of 1.1 kg/s and leave at 95°C . Determine the rate of heat transfer to the air and its outlet temperature.

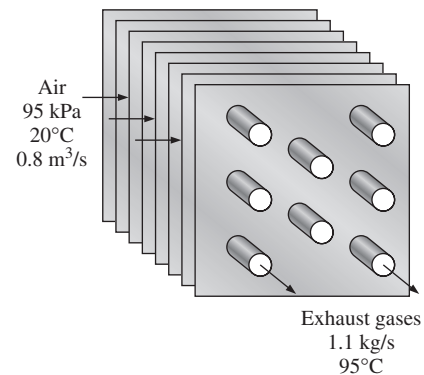

FIGURE P5-89

5-90 An adiabatic open feedwater heater in an electrical power plant mixes 0.2 kg/s of steam at 100 kPa and 160°C with 10 kg/s of feedwater at 100 kPa and 50°C to produce feedwater at 100 kPa and 60°C at the outlet. Determine the outlet mass flow rate and the outlet velocity when the outlet pipe diameter is 0.03 m .

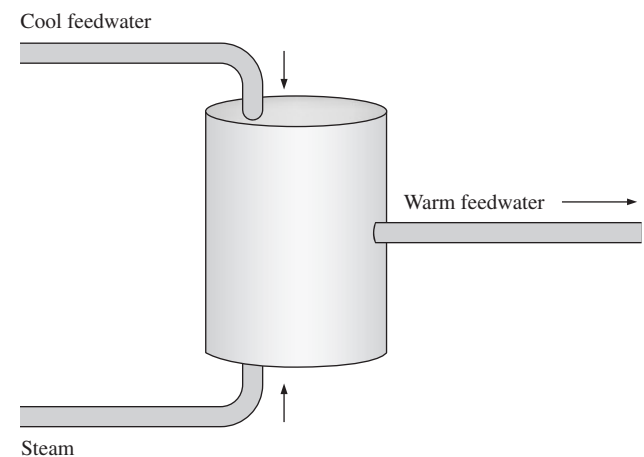

FIGURE P5-90

5-91E An open feedwater heater such as that shown in Fig. P5-90 heats the feedwater by mixing it with hot steam. Consider an electrical power plant with an open feedwater heater that mixes 0.1 lbm/s of steam at 10 psia and 200°F with 2.0 lbm/s of feedwater at 10 psia and 100°F to produce 10 psia and 120°F feedwater at the outlet. The diameter of the outlet pipe is 0.5 ft. Determine the mass flow rate and feedwater velocity at the outlet. Would the outlet flow rate and velocity be significantly different if the temperature at the outlet were 180°F?

5-92 A well-insulated shell-and-tube heat exchanger is used to heat water ($c_p = 4.18 \text{ kJ/kg} \cdot ^\circ\text{C}$) in the tubes from 20 to 70°C at a rate of 4.5 kg/s. Heat is supplied by hot oil ($c_p = 2.30 \text{ kJ/kg} \cdot ^\circ\text{C}$) that enters the shell side at 170°C at a rate of 10 kg/s. Determine the rate of heat transfer in the heat exchanger and the exit temperature of oil.

5-93E Steam is to be condensed on the shell side of a heat exchanger at 85°F. Cooling water enters the tubes at 60°F at a rate of 138 lbm/s and leaves at 73°F. Assuming the heat exchanger to be well-insulated, determine the rate of heat transfer in the heat exchanger and the rate of condensation of the steam.

5-94 An air-conditioning system involves the mixing of cold air and warm outdoor air before the mixture is routed to the conditioned room in steady operation. Cold air enters the mixing chamber at 5°C and 105 kPa at a rate of 1.25 m³/s while warm air enters at 34°C and 105 kPa. The air leaves the room at 24°C. The ratio of the mass flow rates of the hot to cold air streams is 1.6. Using variable specific heats, determine (a) the mixture temperature at the inlet of the room and (b) the rate of heat gain of the room.

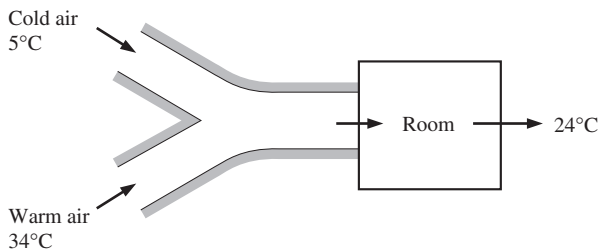

FIGURE P5-94

5-95 Hot exhaust gases of an internal combustion engine are to be used to produce saturated water vapor at 2 MPa pressure. The exhaust gases enter the heat exchanger at 400°C at a rate of 32 kg/min while water enters at 15°C. The heat exchanger is not well insulated, and it is estimated that 10 percent of heat given up by the exhaust gases is lost to the

surroundings. If the mass flow rate of the exhaust gases is 15 times that of the water, determine (a) the temperature of the exhaust gases at the heat exchanger exit and (b) the rate of heat transfer to the water. Use the constant specific heat properties of air for the exhaust gases.

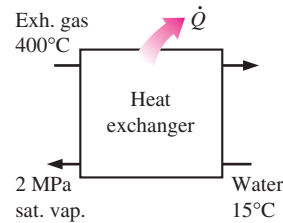

FIGURE P5-95

5-96 Two streams of water are mixed in an insulated container to form a third stream leaving the container. The first stream has a flow rate of 30 kg/s and a temperature of 90°C. The flow rate of the second stream is 200 kg/s, and its temperature is 50°C. What is the temperature of the third stream?

5-97 A chilled-water heat-exchange unit is designed to cool 5 m³/s of air at 100 kPa and 30°C to 100 kPa and 18°C by using water at 8°C. Determine the maximum water outlet temperature when the mass flow rate of the water is 2 kg/s.

Answer: 16.3°C



FIGURE P5-97

Pipe and Duct Flow

5-98 Saturated liquid water is heated in a steady-flow steam boiler at a constant pressure of 5 MPa at a rate of 10 kg/s to an outlet temperature of 350°C. Determine the rate of heat transfer in the boiler.

5-99 A 110-volt electrical heater is used to warm 0.3 m³/s of air at 100 kPa and 15°C to 100 kPa and 30°C. How much current in amperes must be supplied to this heater?

5-100E The fan on a personal computer draws 0.5 ft³/s of air at 14.7 psia and 70°F through the box containing the CPU and other components. Air leaves at 14.7 psia and 80°F. Calculate the electrical power, in kW, dissipated by the PC components. Answer: 0.0948 kW



FIGURE P5-100E

© Vol. 55/PhotoDisc

5-101 A desktop computer is to be cooled by a fan. The electronic components of the computer consume 60 W of power under full-load conditions. The computer is to operate in environments at temperatures up to 45°C and at elevations up to 3400 m where the average atmospheric pressure is 66.63 kPa. The exit temperature of air is not to exceed 60°C to meet the reliability requirements. Also, the average velocity of air is not to exceed 110 m/min at the exit of the computer case where the fan is installed to keep the noise level down. Determine the flow rate of the fan that needs to be installed and the diameter of the casing of the fan.

5-102 Repeat Prob. 5-101 for a computer that consumes 100 W of power.

5-103E Water enters the tubes of a cold plate at 95°F with an average velocity of 60 ft/min and leaves at 105°F. The diameter of the tubes is 0.25 in. Assuming 15 percent of the heat generated is dissipated from the components to the surroundings by convection and radiation, and the remaining 85 percent is removed by the cooling water, determine the amount of heat generated by the electronic devices mounted on the cold plate. *Answer: 263 W*

5-104  The components of an electronic system dissipating 180 W are located in a 1.4-m-long horizontal duct whose cross section is 20 cm × 20 cm. The components in the duct are cooled by forced air that enters the duct at 30°C and 1 atm at a rate of 0.6 m³/min and leaves at 40°C. Determine the rate of heat transfer from the outer surfaces of the duct to the ambient. *Answer: 63 W*

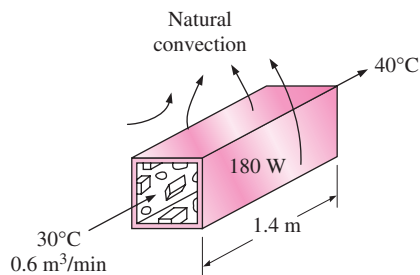

FIGURE P5-104

5-105 Repeat Prob. 5-104 for a circular horizontal duct of diameter 10 cm.

5-106E The hot-water needs of a household are to be met by heating water at 55°F to 180°F by a parabolic solar collector at a rate of 4 lbm/s. Water flows through a 1.25-in-diameter thin aluminum tube whose outer surface is black-anodized in order to maximize its solar absorption ability. The centerline of the tube coincides with the focal line of the collector, and a glass sleeve is placed outside the tube to minimize the heat losses. If solar energy is transferred to water at a net rate of 400 Btu/h per ft length of the tube, determine the required length of the parabolic collector to meet the hot-water requirements of this house.

5-107 Consider a hollow-core printed circuit board 12 cm high and 18 cm long, dissipating a total of 20 W. The width of the air gap in the middle of the PCB is 0.25 cm. If the cooling air enters the 12-cm-wide core at 32°C and 1 atm at a rate of 0.8 L/s, determine the average temperature at which the air leaves the hollow core. *Answer: 53.4°C*

5-108 A computer cooled by a fan contains eight PCBs, each dissipating 10 W power. The height of the PCBs is 12 cm and the length is 18 cm. The cooling air is supplied by a 25-W fan mounted at the inlet. If the temperature rise of air as it flows through the case of the computer is not to exceed 10°C, determine (a) the flow rate of the air that the fan needs to deliver and (b) the fraction of the temperature rise of air that is due to the heat generated by the fan and its motor. *Answers: (a) 0.0104 kg/s, (b) 24 percent*

Answers: (a) 0.0104 kg/s, (b) 24 percent

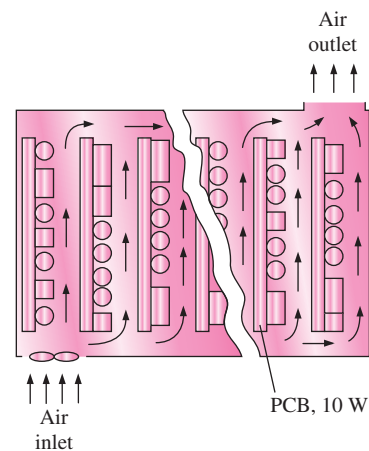



FIGURE P5-108

5-109 Hot water at 90°C enters a 15-m section of a cast iron pipe whose inner diameter is 4 cm at an average velocity of 0.8 m/s. The outer surface of the pipe is exposed to the cold air at 10°C in a basement. If water leaves the basement at 88°C, determine the rate of heat loss from the water.

5-110  Reconsider Prob. 5-109. Using EES (or other) software, investigate the effect of the inner pipe diameter on the rate of heat loss. Let the pipe diameter vary from 1.5 to 7.5 cm. Plot the rate of heat loss against the diameter, and discuss the results.

5-111 A 5-m \times 6-m \times 8-m room is to be heated by an electric resistance heater placed in a short duct in the room. Initially, the room is at 15°C, and the local atmospheric pressure is 98 kPa. The room is losing heat steadily to the outside at a rate of 200 kJ/min. A 200-W fan circulates the air steadily through the duct and the electric heater at an average mass flow rate of 50 kg/min. The duct can be assumed to be adiabatic, and there is no air leaking in or out of the room. If it takes 15 min for the room air to reach an average temperature of 25°C, find (a) the power rating of the electric heater and (b) the temperature rise that the air experiences each time it passes through the heater.

5-112 A house has an electric heating system that consists of a 300-W fan and an electric resistance heating element placed in a duct. Air flows steadily through the duct at a rate of 0.6 kg/s and experiences a temperature rise of 7°C. The rate of heat loss from the air in the duct is estimated to be 300 W. Determine the power rating of the electric resistance heating element. *Answer: 4.22 kW*

5-113 A hair dryer is basically a duct in which a few layers of electric resistors are placed. A small fan pulls the air in and forces it through the resistors where it is heated. Air enters a 1200-W hair dryer at 100 kPa and 22°C and leaves at 47°C. The cross-sectional area of the hair dryer at the exit is 60 cm². Neglecting the power consumed by the fan and the heat losses through the walls of the hair dryer, determine (a) the volume flow rate of air at the inlet and (b) the velocity of the air at the exit. *Answers: (a) 0.0404 m³/s, (b) 7.31 m/s*

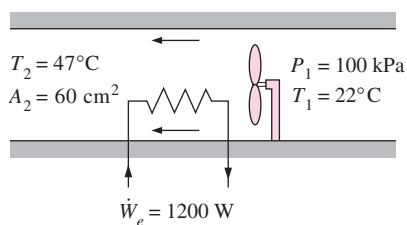



FIGURE P5-113

5-114  Reconsider Prob. 5-113. Using EES (or other) software, investigate the effect of the exit cross-sectional area of the hair dryer on the exit velocity. Let the exit area vary from 25 to 75 cm². Plot the exit velocity against the exit cross-sectional area, and discuss the results. Include the effect of the flow kinetic energy in the analysis.

5-115 The ducts of an air heating system pass through an unheated area. As a result of heat losses, the temperature of the air in the duct drops by 4°C. If the mass flow rate of air is 120 kg/min, determine the rate of heat loss from the air to the cold environment.

5-116 Steam enters a long, horizontal pipe with an inlet diameter of $D_1 = 12$ cm at 1 MPa and 300°C with a velocity of 2 m/s. Farther downstream, the conditions are 800 kPa and 250°C, and the diameter is $D_2 = 10$ cm. Determine (a) the mass flow rate of the steam and (b) the rate of heat transfer. *Answers: (a) 0.0877 kg/s, (b) 8.87 kJ/s*

5-117 Steam enters an insulated pipe at 200 kPa and 200°C and leaves at 150 kPa and 150°C. The inlet-to-outlet diameter ratio for the pipe is $D_1/D_2 = 1.80$. Determine the inlet and exit velocities of the steam.

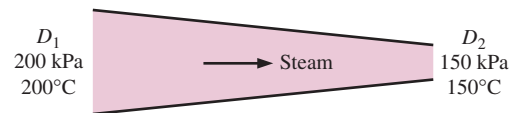

FIGURE P5-117

5-118E Water enters a boiler at 500 psia as a saturated liquid and leaves at 600°F at the same pressure. Calculate the heat transfer per unit mass of water.

5-119 Refrigerant-134a enters the condenser of a refrigerator at 1200 kPa and 80°C, and leaves as a saturated liquid at the same pressure. Determine the heat transfer from the refrigerant per unit mass.

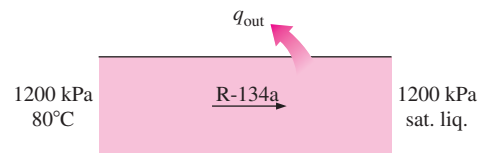

FIGURE P5-119

5-120 Saturated liquid water is heated at constant pressure in a steady-flow device until it is a saturated vapor. Calculate the heat transfer, in kJ/kg, when the vaporization is done at a pressure of 800 kPa.

Charging and Discharging Processes

5-121 A rigid, insulated tank that is initially evacuated is connected through a valve to a supply line that carries helium at 200 kPa and 120°C. Now the valve is opened, and helium is allowed to flow into the tank until the pressure reaches 200 kPa, at which point the valve is closed. Determine the flow

work of the helium in the supply line and the final temperature of the helium in the tank. *Answers: 816 kJ/kg, 655 K*

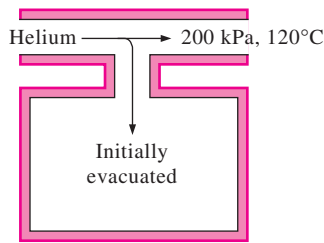

FIGURE P5-121

5-122 Consider an 8-L evacuated rigid bottle that is surrounded by the atmosphere at 100 kPa and 17°C. A valve at the neck of the bottle is now opened and the atmospheric air is allowed to flow into the bottle. The air trapped in the bottle eventually reaches thermal equilibrium with the atmosphere as a result of heat transfer through the wall of the bottle. The valve remains open during the process so that the trapped air also reaches mechanical equilibrium with the atmosphere. Determine the net heat transfer through the wall of the bottle during this filling process. *Answer: $Q_{\text{out}} = 0.8 \text{ kJ}$*

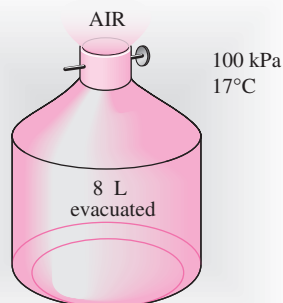

FIGURE P5-122

5-123 An insulated rigid tank is initially evacuated. A valve is opened, and atmospheric air at 95 kPa and 17°C enters the tank until the pressure in the tank reaches 95 kPa, at which point the valve is closed. Determine the final temperature of the air in the tank. Assume constant specific heats. *Answer: 406 K*

5-124 A 2-m³ rigid tank initially contains air at 100 kPa and 22°C. The tank is connected to a supply line through a valve. Air is flowing in the supply line at 600 kPa and 22°C. The valve is opened, and air is allowed to enter the tank until the pressure in the tank reaches the line pressure, at which point the valve is closed. A thermometer placed in the tank indicates

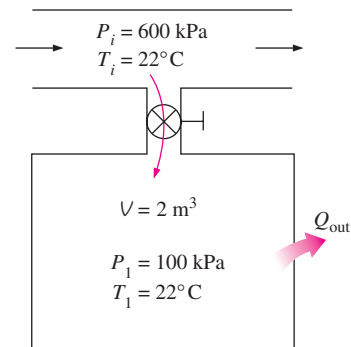

FIGURE P5-124

that the air temperature at the final state is 77°C. Determine (a) the mass of air that has entered the tank and (b) the amount of heat transfer. *Answers: (a) 9.58 kg, (b) $Q_{\text{out}} = 339 \text{ kJ}$*

5-125 A 0.2-m³ rigid tank initially contains refrigerant-134a at 8°C. At this state, 70 percent of the mass is in the vapor phase, and the rest is in the liquid phase. The tank is connected by a valve to a supply line where refrigerant at 1 MPa and 100°C flows steadily. Now the valve is opened slightly, and the refrigerant is allowed to enter the tank. When the pressure in the tank reaches 800 kPa, the entire refrigerant in the tank exists in the vapor phase only. At this point the valve is closed. Determine (a) the final temperature in the tank, (b) the mass of refrigerant that has entered the tank, and (c) the heat transfer between the system and the surroundings.

5-126 An insulated, vertical piston-cylinder device initially contains 10 kg of water, 6 kg of which is in the vapor phase. The mass of the piston is such that it maintains a constant pressure of 200 kPa inside the cylinder. Now steam at 0.5 MPa and 350°C is allowed to enter the cylinder from a supply line until all the liquid in the cylinder has vaporized. Determine (a) the final temperature in the cylinder and (b) the mass of the steam that has entered. *Answers: (a) 120.2°C, (b) 19.07 kg*

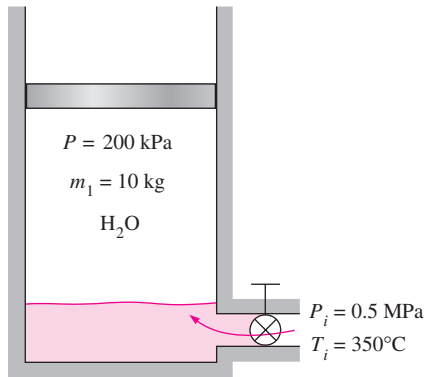

FIGURE P5-126

5-127E A scuba diver's 2-ft³ air tank is to be filled with air from a compressed air line at 120 psia and 100°F. Initially, the air in this tank is at 20 psia and 70°F. Presuming that the tank is well insulated, determine the temperature and mass in the tank when it is filled to 120 psia.

5-128 An air-conditioning system is to be filled from a rigid container that initially contains 5 kg of liquid R-134a at 24°C. The valve connecting this container to the air-conditioning system is now opened until the mass in the container is 0.25 kg, at which time the valve is closed. During this time, only liquid R-134a flows from the container. Presuming that the process is isothermal while the valve is open, determine the final quality of the R-134a in the container and the total heat transfer. *Answers: 0.506, 22.6 kJ*

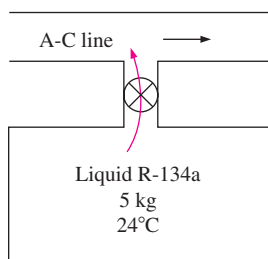

FIGURE P5-128

5-129E Oxygen is supplied to a medical facility from ten 3-ft³ compressed oxygen tanks. Initially, these tanks are at 2000 psia and 80°F. The oxygen is removed from these tanks slowly enough that the temperature in the tanks remains at 80°F. After two weeks, the pressure in the tanks is 100 psia. Determine the mass of oxygen used and the total heat transfer to the tanks.

5-130 The air in an insulated, rigid compressed-air tank whose volume is 0.5 m³ is initially at 4000 kPa and 20°C.

Enough air is now released from the tank to reduce the pressure to 2000 kPa. Following this release, what is the temperature of the remaining air in the tank?



FIGURE P5-130

© Vol. OS52/PhotoDisc

5-131E The weighted piston of the device shown in Fig. P5-131E maintains the pressure of the piston-cylinder contents at 200 psia. Initially, this system contains no mass. The valve is now opened, and steam from the line flows into the cylinder until the volume is 10 ft³. This process is adiabatic, and the steam in the line remains at 300 psia and 450°F. Determine the final temperature (and quality if appropriate) of the steam in the cylinder and the total work produced as the device is filled.

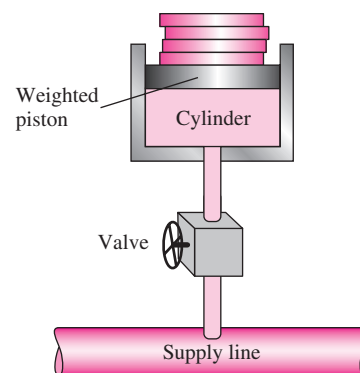

FIGURE P5-131E

5-132E Repeat Prob. 5-131E when the supply line carries oxygen at 300 psia and 450°F. *Answers: 450°F, 370 Btu*

5-133 A 0.12-m³ rigid tank initially contains refrigerant-134a at 1 MPa and 100 percent quality. The tank is connected by a valve to a supply line that carries refrigerant-134a at 1.2 MPa and 36°C. Now the valve is opened, and the refrigerant is allowed to enter the tank. The valve is closed when it is observed that the tank contains saturated liquid at 1.2 MPa.

Determine (a) the mass of the refrigerant that has entered the tank and (b) the amount of heat transfer. *Answers: (a) 128.4 kg, (b) 1057 kJ*

5-134 A 0.3-m³ rigid tank is filled with saturated liquid water at 200°C. A valve at the bottom of the tank is opened, and liquid is withdrawn from the tank. Heat is transferred to the water such that the temperature in the tank remains constant. Determine the amount of heat that must be transferred by the time one-half of the total mass has been withdrawn.

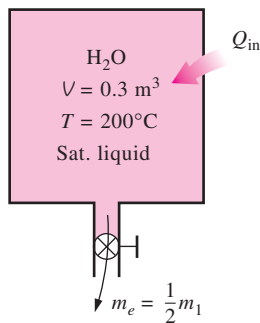

FIGURE P5-134

5-135 A 0.12-m³ rigid tank contains saturated refrigerant-134a at 800 kPa. Initially, 25 percent of the volume is occupied by liquid and the rest by vapor. A valve at the bottom of the tank is now opened, and liquid is withdrawn from the tank. Heat is transferred to the refrigerant such that the pressure inside the tank remains constant. The valve is closed when no liquid is left in the tank and vapor starts to come out. Determine the total heat transfer for this process.

Answer: 201.2 kJ

5-136E A 4-ft³ rigid tank contains saturated refrigerant-134a at 100 psia. Initially, 20 percent of the volume is occupied by liquid and the rest by vapor. A valve at the top of the tank is now opened, and vapor is allowed to escape slowly from the tank. Heat is transferred to the refrigerant such that the pressure inside the tank remains constant. The valve is closed when the last drop of liquid in the tank is vaporized. Determine the total heat transfer for this process.

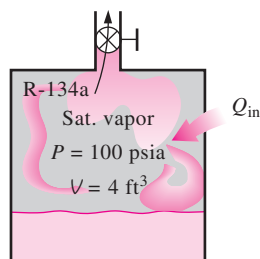

FIGURE P5-136E

5-137 A 0.2-m³ rigid tank equipped with a pressure regulator contains steam at 2 MPa and 300°C. The steam in the tank is now heated. The regulator keeps the steam pressure constant by letting out some steam, but the temperature inside rises. Determine the amount of heat transferred when the steam temperature reaches 500°C.

5-138 An adiabatic piston-cylinder device equipped with a spring maintains the pressure inside at 300 kPa when the volume is 0, and 3000 kPa when the volume is 5 m³. The device is connected to a steam line maintained at 1500 kPa and 200°C, and initially the volume is 0. Determine the final temperature (and quality if appropriate) when valve is opened and steam in the line is allowed to enter the cylinder until the pressure inside matches that in the line. Also determine the total work produced during this adiabatic filling process.

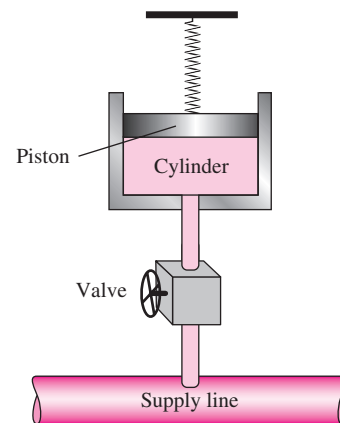

FIGURE P5-138

5-139 Repeat Prob. 5-138 when the line is filled with air that is maintained at 2000 kPa and 250°C.

5-140 The air-release flap on a hot-air balloon is used to release hot air from the balloon when appropriate. On one hot-air balloon, the air release opening has an area of 0.5 m², and the filling opening has an area of 1 m². During a two minute adiabatic flight maneuver, hot air enters the balloon at 100 kPa and 35°C with a velocity of 2 m/s; the air in the balloon remains at 100 kPa and 35°C; and air leaves the balloon through the air-release flap at velocity 1 m/s. At the start of this maneuver, the volume of the balloon is 75 m³. Determine the final volume of the balloon and work produced by the air inside the balloon as it expands the balloon skin.



FIGURE P5-140

© Vol. 1/PhotoDisc

5-141 An insulated 0.08-m^3 tank contains helium at 2 MPa and 80°C . A valve is now opened, allowing some helium to escape. The valve is closed when one-half of the initial mass has escaped. Determine the final temperature and pressure in the tank. *Answers: 225 K, 637 kPa*

5-142E An insulated 60-ft^3 rigid tank contains air at 75 psia and 120°F . A valve connected to the tank is now opened, and air is allowed to escape until the pressure inside drops to 30 psia. The air temperature during this process is maintained constant by an electric resistance heater placed in the tank. Determine the electrical work done during this process.

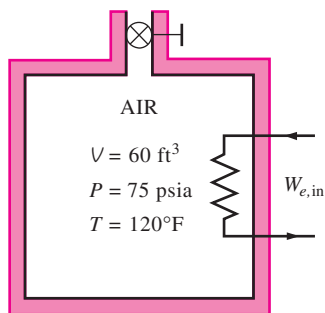

FIGURE P5-142E

5-143 A vertical piston–cylinder device initially contains 0.2 m^3 of air at 20°C . The mass of the piston is such that it maintains a constant pressure of 300 kPa inside. Now a valve connected to the cylinder is opened, and air is allowed to escape until the volume inside the cylinder is decreased by one-half. Heat transfer takes place during the process so that the temperature of the air in the cylinder remains constant. Determine (a) the amount of air that has left the cylinder and (b) the amount of heat transfer. *Answers: (a) 0.357 kg, (b) 0*

5-144 A balloon initially contains 65 m^3 of helium gas at atmospheric conditions of 100 kPa and 22°C . The balloon is connected by a valve to a large reservoir that supplies helium gas at 150 kPa and 25°C . Now the valve is opened, and helium is allowed to enter the balloon until pressure equilibrium with the helium at the supply line is reached. The material of the balloon is such that its volume increases linearly with pressure. If no heat transfer takes place during this process, determine the final temperature in the balloon. *Answer: 334 K*

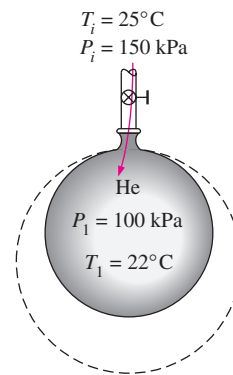

FIGURE P5-144

5-145 An insulated vertical piston–cylinder device initially contains 0.8 m^3 of refrigerant-134a at 1.2 MPa and 120°C . A linear spring at this point applies full force to the piston. A valve connected to the cylinder is now opened, and refrigerant is allowed to escape. The spring unwinds as the piston moves down, and the pressure and volume drop to 0.6 MPa and 0.5 m^3 at the end of the process. Determine (a) the amount of refrigerant that has escaped and (b) the final temperature of the refrigerant.

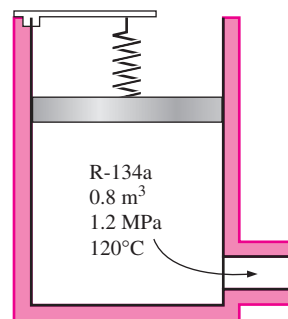

FIGURE P5-145

5-146 A piston–cylinder device initially contains 0.6 kg of steam with a volume of 0.1 m^3 . The mass of the piston is such that it maintains a constant pressure of 800 kPa. The cylinder is connected through a valve to a supply line that carries steam at 5 MPa and 500°C . Now the valve is opened

and steam is allowed to flow slowly into the cylinder until the volume of the cylinder doubles and the temperature in the cylinder reaches 250°C , at which point the valve is closed. Determine (a) the mass of steam that has entered and (b) the amount of heat transfer.

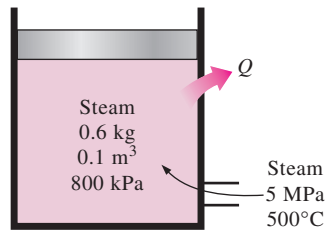

FIGURE P5-146

Review Problems

5-147 A $D_0 = 10\text{-m}$ -diameter tank is initially filled with water 2 m above the center of a $D = 10\text{-cm}$ -diameter valve near the bottom. The tank surface is open to the atmosphere, and the tank drains through a $L = 100\text{-m}$ -long pipe connected to the valve. The friction factor of the pipe is given to be $f = 0.015$, and the discharge velocity is expressed as

$$V = \sqrt{\frac{2gz}{1.5 + fL/D}}$$

where z is the water height above the center of the valve. Determine (a) the initial discharge velocity from the tank and (b) the time required to empty the tank. The tank can be considered to be empty when the water level drops to the center of the valve.

5-148 Underground water is being pumped into a pool whose cross section is $3\text{ m} \times 4\text{ m}$ while water is discharged through a 5-cm-diameter orifice at a constant average velocity of 5 m/s. If the water level in the pool rises at a rate of 1.5 cm/min, determine the rate at which water is supplied to the pool, in m^3/s .

5-149 The velocity of a liquid flowing in a circular pipe of radius R varies from zero at the wall to a maximum at the pipe center. The velocity distribution in the pipe can be represented as $V(r)$, where r is the radial distance from the pipe center. Based on the definition of mass flow rate \dot{m} , obtain a relation for the average velocity in terms of $V(r)$, R , and r .

5-150 Air at 4.18 kg/m^3 enters a nozzle that has an inlet-to-exit area ratio of 2:1 with a velocity of 120 m/s and leaves with a velocity of 380 m/s. Determine the density of air at the exit. *Answer: 2.64 kg/m^3*

5-151E Consider a heat exchanger that uses hot air to heat cold water. Air enters this heat exchanger at 20 psia and 200°F at a rate of $100\text{ ft}^3/\text{min}$ and leaves at 17 psia and 100°F . Water enters this unit at 20 psia and 50°F at a rate of 0.5 lbm/s and exits at 17 psia and 90°F . Determine the total flow power, in hp, required for this unit and the flow work, in Btu/lbm, for both the air and water streams.

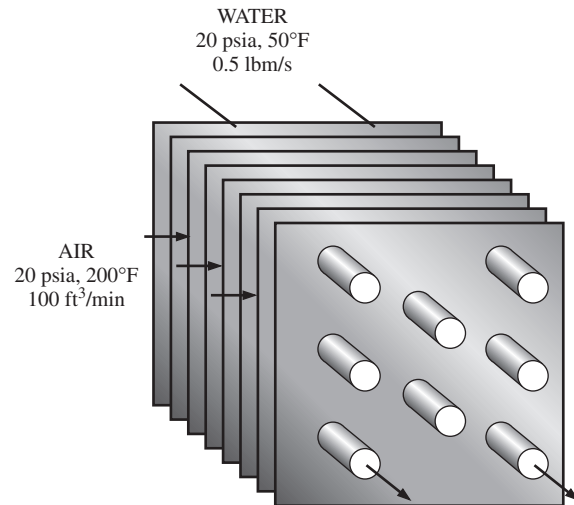

FIGURE P5-151E

5-152 An air compressor compresses 10 L/s of air at 120 kPa and 20°C to 1000 kPa and 300°C while consuming 4.5 kW of power. How much of this power is being used to increase the pressure of the air versus the power needed to move the fluid through the compressor? *Answers: 3.35 kW, 1.15 kW*

5-153 A steam turbine operates with 1.6 MPa and 350°C steam at its inlet and saturated vapor at 30°C at its exit. The mass flow rate of the steam is 16 kg/s, and the turbine produces 9000 kW of power. Determine the rate at which heat is lost through the casing of this turbine.

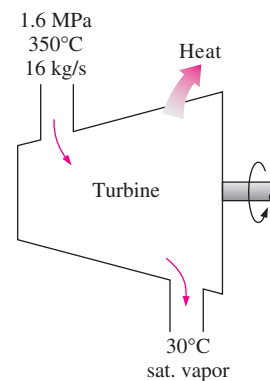

FIGURE P5-153

5-154E Nitrogen gas flows through a long, constant-diameter adiabatic pipe. It enters at 100 psia and 120°F and leaves at 50 psia and 70°F . Calculate the velocity of the nitrogen at the pipe's inlet and outlet.

5-155 A 110-V electric hot-water heater warms 0.1 L/s of water from 15 to 20°C . Calculate the current in amperes that must be supplied to this heater. *Answer: 19.0 A*

5-156 Steam enters a long, insulated pipe at 1400 kPa, 350°C, and 10 m/s, and exits at 1000 kPa. The diameter of the pipe is 0.15 m at the inlet, and 0.1 m at the exit. Calculate the mass flow rate of the steam and its speed at the pipe outlet.

5-157 The air flow in a compressed air line is divided into two equal streams by a T-fitting in the line. The compressed air enters this 2.5-cm diameter fitting at 1.6 MPa and 40°C with a velocity of 50 m/s. Each outlet has the same diameter as the inlet, and the air at these outlets has a pressure of 1.4 MPa and a temperature of 36°C. Determine the velocity of the air at the outlets and the rate of change of flow energy (flow power) across the T-fitting.

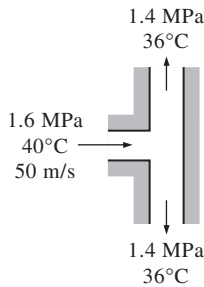

FIGURE P5-157

5-158 Air enters a pipe at 50°C and 200 kPa and leaves at 40°C and 150 kPa. It is estimated that heat is lost from the pipe in the amount of 3.3 kJ per kg of air flowing in the pipe. The diameter ratio for the pipe is $D_1/D_2 = 1.8$. Using constant specific heats for air, determine the inlet and exit velocities of the air. *Answers: 28.6 m/s, 120 m/s*

5-159 The hot-water needs of a household are met by a 60-L electric water heater whose heaters are rated at 1.6 kW. The hot-water tank is initially full with hot water at 80°C. Somebody takes a shower by mixing a constant flow of hot water from the tank with cold water at 20°C at a rate of 0.06 kg/s. After a shower period of 8 min, the water temperature in the tank is measured to drop to 60°C. The heater remained on during the shower and hot water withdrawn from the tank is replaced by cold water at the same flow rate. Determine the mass flow rate of hot water withdrawn from the tank during the shower and the average temperature of mixed water used for the shower.

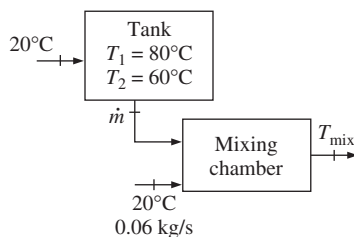

FIGURE P5-159

5-160 In a gas-fired boiler, water is boiled at 150°C by hot gases flowing through a stainless steel pipe submerged in water. If the rate of heat transfer from the hot gases to water is 74 kJ/s, determine the rate of evaporation of water.

5-161 Cold water enters a steam generator at 20°C and leaves as saturated vapor at 150°C. Determine the fraction of heat used in the steam generator to preheat the liquid water from 20°C to the saturation temperature of 150°C.

5-162 Cold water enters a steam generator at 20°C and leaves as saturated vapor at the boiler pressure. At what pressure will the amount of heat needed to preheat the water to saturation temperature be equal to the heat needed to vaporize the liquid at the boiler pressure?

5-163 Water is boiled at 100°C electrically by a 3-kW resistance wire. Determine the rate of evaporation of water.

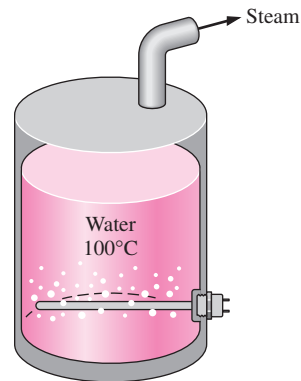

FIGURE P5-163

5-164 Two streams of the same ideal gas having different mass flow rates and temperatures are mixed in a steady-flow, adiabatic mixing device. Assuming constant specific heats, find the simplest expression for the mixture temperature written in the form

$$T_3 = f\left(\frac{\dot{m}_1}{\dot{m}_3}, \frac{\dot{m}_2}{\dot{m}_3}, T_1, T_2\right)$$



FIGURE P5-164

5-165 An ideal gas expands in an adiabatic turbine from 1200 K and 600 kPa to 700 K. Determine the turbine inlet volume flow rate of the gas, in m³/s, required to produce turbine work output at the rate of 200 kW. The average values of the specific heats for this gas over the temperature range and the gas constant are $c_p = 1.13$ kJ/kg · K, $c_v = 0.83$ kJ/kg · K, and $R = 0.30$ kJ/kg · K.

5-166 Consider a large classroom on a hot summer day with 150 students, each dissipating 60 W of sensible heat. All the lights, with 6.0 kW of rated power, are kept on. The room has no external walls, and thus heat gain through the walls and the roof is negligible. Chilled air is available at 15°C, and the temperature of the return air is not to exceed 25°C. Determine the required flow rate of air, in kg/s, that needs to be supplied to the room to keep the average temperature of the room constant. *Answer: 1.49 kg/s*

5-167 Chickens with an average mass of 2.2 kg and average specific heat of 3.54 kJ/kg · °C are to be cooled by chilled water that enters a continuous-flow-type immersion chiller at 0.5°C. Chickens are dropped into the chiller at a uniform temperature of 15°C at a rate of 500 chickens per hour and are cooled to an average temperature of 3°C before they are taken out. The chiller gains heat from the surroundings at a rate of 200 kJ/h. Determine (a) the rate of heat removal from the chickens, in kW, and (b) the mass flow rate of water, in kg/s, if the temperature rise of water is not to exceed 2°C.

5-168 Repeat Prob. 5-167 assuming heat gain of the chiller is negligible.

5-169 In a dairy plant, milk at 4°C is pasteurized continuously at 72°C at a rate of 12 L/s for 24 h a day and 365 days a year. The milk is heated to the pasteurizing temperature by hot water heated in a natural-gas-fired boiler that has an efficiency of 82 percent. The pasteurized milk is then cooled by cold water at 18°C before it is finally refrigerated back to 4°C. To save energy and money, the plant installs a regenerator that has an effectiveness of 82 percent. If the cost of natural gas is \$1.10/therm (1 therm = 105,500 kJ), determine how much energy and money the regenerator will save this company per year.

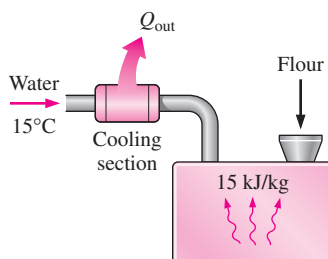

FIGURE P5-169

5-170E A refrigeration system is being designed to cool eggs ($\rho = 67.4 \text{ lbm/ft}^3$ and $c_p = 0.80 \text{ Btu/lbm} \cdot \text{°F}$) with an average mass of 0.14 lbm from an initial temperature of 90°F to a final average temperature of 50°F by air at 34°F at a rate of 10,000 eggs per hour. Determine (a) the rate of heat removal from the eggs, in Btu/h and (b) the required volume flow rate of air, in ft³/h, if the temperature rise of air is not to exceed 10°F.

5-171 A glass bottle washing facility uses a well-agitated hot-water bath at 55°C that is placed on the ground. The bottles enter at a rate of 800 per minute at an ambient temperature of 20°C and leave at the water temperature. Each bottle has a mass of 150 g and removes 0.2 g of water as it leaves the bath wet. Make-up water is supplied at 15°C. Disregarding any heat losses from the outer surfaces of the bath, determine the rate at which (a) water and (b) heat must be supplied to maintain steady operation.

5-172 Repeat Prob. 5-171 for a water bath temperature of 50°C.

5-173 Long aluminum wires of diameter 3 mm ($\rho = 2702 \text{ kg/m}^3$ and $c_p = 0.896 \text{ kJ/kg} \cdot \text{°C}$) are extruded at a temperature of 350°C and are cooled to 50°C in atmospheric air at 30°C. If the wire is extruded at a velocity of 10 m/min, determine the rate of heat transfer from the wire to the extrusion room.

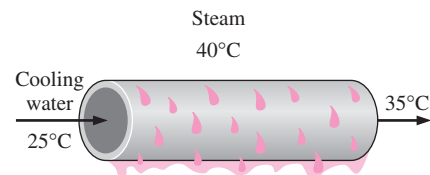

FIGURE P5-173

5-174 Repeat Prob. 5-173 for a copper wire ($\rho = 8950 \text{ kg/m}^3$ and $c_p = 0.383 \text{ kJ/kg} \cdot \text{°C}$).

5-175 Steam at 40°C condenses on the outside of a 5-m-long, 3-cm-diameter thin horizontal copper tube by cooling water that enters the tube at 25°C at an average velocity of 2 m/s and leaves at 35°C. Determine the rate of condensation of steam. *Answer: 0.0245 kg/s*

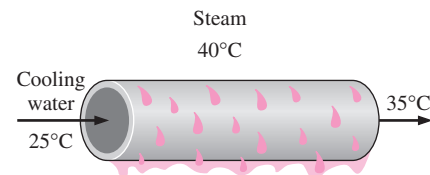

FIGURE P5-175

5-176E Steam at 60 psia and 350°F is mixed with water at 40°F and 60 psia steadily in an adiabatic device. Steam enters the device at a rate of 0.05 lbm/s, while the water enters at 1 lbm/s. Determine the temperature of the mixture leaving this device when the outlet pressure is 60 psia. *Answer: 97°F*

5-177 A constant-pressure R-134a vapor separation unit separates the liquid and vapor portions of a saturated mixture into two separate outlet streams. Determine the flow power needed to pass 3 L/s of R-134a at 200 kPa and 70 percent

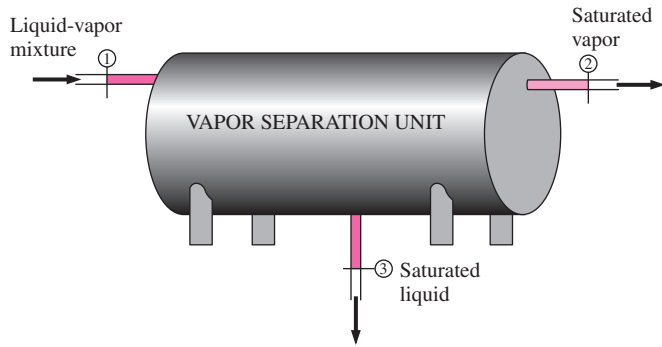

FIGURE P5-177

quality through this unit. What is the mass flow rate, in kg/s, of the two outlet streams?

5-178E A small positioning control rocket in a satellite is driven by a 2-ft³ container filled with R-134a at -10°F. Upon launch, the container is completely filled with saturated liquid R-134a. The rocket is designed for short bursts of 5-s duration. During each burst, the mass flow rate leaving the rocket is 0.05 lbm/s. How many such bursts can this rocket experience before the quality in the container is 90 percent or more, presuming that the temperature of the container contents is maintained at -10°F? *Answers: 680*

5-179E During the inflation and deflation of a safety airbag in an automobile, the gas enters the airbag with a specific volume of 15 ft³/lbm and at a mass flow rate that varies with time as illustrated in Fig. P5-179E. The gas leaves this airbag with a specific volume of 13 ft³/lbm, with a mass flow rate that varies with time, as shown in Fig. P5-179E. Plot the volume of this bag (i.e., airbag size) as a function of time, in ft³.

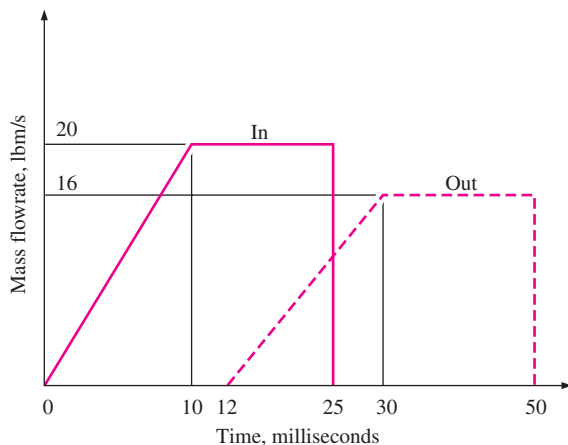

FIGURE P5-179E

5-180 A rigid container filled with an ideal gas is heated while the gas is released so that the temperature of the gas remaining in the container stays constant. This container has

a single outlet. Derive an expression for the mass flow rate at the outlet as a function of the rate of pressure change in the container.

5-181E The average atmospheric pressure in Spokane, Washington (elevation = 2350 ft), is 13.5 psia, and the average winter temperature is 36.5°F. The pressurization test of a 9-ft-high, 3000-ft² older home revealed that the seasonal average infiltration rate of the house is 2.2 air changes per hour (ACH). That is, the entire air in the house is replaced completely 2.2 times per hour by the outdoor air. It is suggested that the infiltration rate of the house can be reduced by half to 1.1 ACH by winterizing the doors and the windows. If the house is heated by natural gas whose unit cost is \$1.24/therm and the heating season can be taken to be six months, determine how much the home owner will save from the heating costs per year by this winterization project. Assume the house is maintained at 72°F at all times and the efficiency of the furnace is 0.65. Also assume the latent heat load during the heating season to be negligible.

5-182 Determine the rate of sensible heat loss from a building due to infiltration if the outdoor air at -5°C and 90 kPa enters the building at a rate of 35 L/s when the indoors is maintained at 20°C.

5-183 A fan is powered by a 0.5-hp motor and delivers air at a rate of 85 m³/min. Determine the highest value for the average velocity of air mobilized by the fan. Take the density of air to be 1.18 kg/m³.

5-184 An air-conditioning system requires airflow at the main supply duct at a rate of 180 m³/min. The average velocity of air in the circular duct is not to exceed 10 m/s to avoid excessive vibration and pressure drops. Assuming the fan converts 70 percent of the electrical energy it consumes into kinetic energy of air, determine the size of the electric motor needed to drive the fan and the diameter of the main duct. Take the density of air to be 1.20 kg/m³.

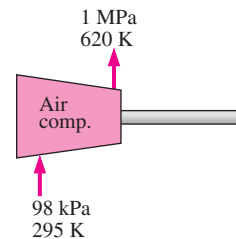

FIGURE P5-184

5-185 Consider an evacuated rigid bottle of volume V that is surrounded by the atmosphere at pressure P_0 and tempera-

ture T_0 . A valve at the neck of the bottle is now opened and the atmospheric air is allowed to flow into the bottle. The air trapped in the bottle eventually reaches thermal equilibrium with the atmosphere as a result of heat transfer through the wall of the bottle. The valve remains open during the process so that the trapped air also reaches mechanical equilibrium with the atmosphere. Determine the net heat transfer through the wall of the bottle during this filling process in terms of the properties of the system and the surrounding atmosphere.

5-186 An adiabatic air compressor is to be powered by a direct-coupled adiabatic steam turbine that is also driving a generator. Steam enters the turbine at 12.5 MPa and 500°C at a rate of 25 kg/s and exits at 10 kPa and a quality of 0.92. Air enters the compressor at 98 kPa and 295 K at a rate of 10 kg/s and exits at 1 MPa and 620 K. Determine the net power delivered to the generator by the turbine.

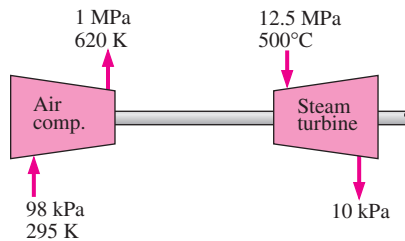

FIGURE P5-186

5-187 Determine the power input for a compressor that compresses helium from 150 kPa and 20°C to 400 kPa and 200°C. Helium enters this compressor through a 0.1-m² pipe at a velocity of 15 m/s.

5-188 Submarines change their depth by adding or removing air from rigid ballast tanks, thereby displacing seawater in the tanks. Consider a submarine that has a 1000 m³ air-ballast tank originally partially filled with 100 m³ of air at 2000 kPa and 15°C. For the submarine to surface, air at 2000 kPa and 20°C is pumped into the ballast tank, until it is entirely filled with air. The tank is filled so quickly that the process is adiabatic and the seawater leaves the tank at 15°C. Determine the final temperature and mass of the air in the ballast tank.

5-189 In the preceding problem, presume that air is added to the tank in such a way that the temperature and pressure of the air in the tank remain constant. Determine the final mass of the air in the ballast tank under this condition. Also determine the total heat transfer while the tank is being filled in this manner.

5-190 A steel cylinder initially contains nitrogen gas at 200 kPa and 25°C. The cylinder is connected to a supply line containing nitrogen at 800 kPa and 25°C. A valve is opened, allowing nitrogen to flow into the cylinder until the pressure reaches 800 kPa. The cylinder internal volume is 0.1 m³,

its mass (cylinder only) is 50 kg, and its specific heat is 0.43 kJ/kg · K. Find the final mass of nitrogen in the tank and the final temperature of the nitrogen assuming constant specific heats at room temperature for nitrogen, and assuming (a) no heat transfer from the nitrogen to the tank, and (b) rapid heat transfer between the nitrogen and tank such that the cylinder and nitrogen remain in thermal equilibrium during the process (with negligible heat transfer from the cylinder to its external surroundings.) *Answers: (a) 380 K, 0.733 kg, (b) 301 K, 0.927 kg*

5-191 A tank with an internal volume of 1 m³ contains air at 800 kPa and 25°C. A valve on the tank is opened allowing air to escape and the pressure inside quickly drops to 150 kPa, at which point the valve is closed. Assume there is negligible heat transfer from the tank to the air left in the tank.

(a) Using the approximation $h_e \approx \text{constant} = h_{e,\text{avg}} = 0.5(h_1 + h_2)$, calculate the mass withdrawn during the process.

(b) Consider the same process but broken into two parts. That is, consider an intermediate state at $P_2 = 400$ kPa, calculate the mass removed during the process from $P_1 = 800$ kPa to P_2 and then the mass removed during the process from P_2 to $P_3 = 150$ kPa, using the type of approximation used in part (a), and add the two to get the total mass removed.

(c) Calculate the mass removed if the variation of h_e is accounted for.

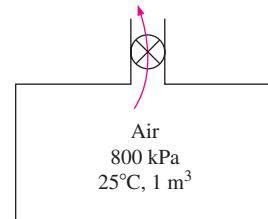



FIGURE P5-191

5-192 A liquid R-134a bottle has an internal volume of 0.001 m³. Initially it contains 0.4 kg of R-134a (saturated mixture) at 26°C. A valve is opened and R-134a vapor only (no liquid) is allowed to escape slowly such that temperature remains constant until the mass of R-134a remaining is 0.1 kg. Find the heat transfer necessary with the surroundings to maintain the temperature and pressure of the R-134a constant.

5-193  Steam enters a turbine steadily at 10 MPa and 550°C with a velocity of 60 m/s and leaves at 25 kPa with a quality of 95 percent. A heat loss of 30 kJ/kg occurs during the process. The inlet area of the turbine is 150 cm², and the exit area is 1400 cm². Determine (a) the mass flow rate of the steam, (b) the exit velocity, and (c) the power output.

5-194  Reconsider Prob. 5-193. Using EES (or other) software, investigate the effects of turbine exit

area and turbine exit pressure on the exit velocity and power output of the turbine. Let the exit pressure vary from 10 to 50 kPa (with the same quality), and the exit area to vary from 1000 to 3000 cm². Plot the exit velocity and the power outlet against the exit pressure for the exit areas of 1000, 2000, and 3000 cm², and discuss the results.

5–195E Refrigerant-134a enters an adiabatic compressor at 15 psia and 20°F with a volume flow rate of 10 ft³/s and leaves at a pressure of 100 psia. The power input to the compressor is 45 hp. Find (a) the mass flow rate of the refrigerant and (b) the exit temperature.

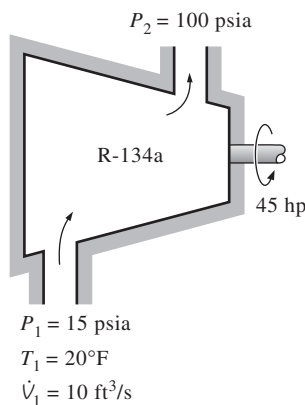

FIGURE P5–195E

5–196 In large gas-turbine power plants, air is preheated by the exhaust gases in a heat exchanger called the *regenerator* before it enters the combustion chamber. Air enters the regenerator at 1 MPa and 550 K at a mass flow rate of 800 kg/min. Heat is transferred to the air at a rate of 3200 kJ/s. Exhaust gases enter the regenerator at 140 kPa and 800 K and leave at 130 kPa and 600 K. Treating the exhaust gases as air, determine (a) the exit temperature of the air and (b) the mass flow rate of exhaust gases. *Answers: (a) 775 K, (b) 14.9 kg/s*

5–197 It is proposed to have a water heater that consists of an insulated pipe of 5-cm diameter and an electric resistor inside. Cold water at 20°C enters the heating section steadily at a rate of 30 L/min. If water is to be heated to 55°C, determine (a) the power rating of the resistance heater and (b) the average velocity of the water in the pipe.

5–198 An insulated vertical piston–cylinder device initially contains 0.2 m³ of air at 200 kPa and 22°C. At this state, a linear spring touches the piston but exerts no force on it. The cylinder is connected by a valve to a line that supplies air at 800 kPa and 22°C. The valve is opened, and air from the high-pressure line is allowed to enter the cylinder. The valve is turned off when the pressure inside the cylinder reaches 600 kPa. If the enclosed volume inside the cylinder doubles during this process, determine

(a) the mass of air that entered the cylinder, and (b) the final temperature of the air inside the cylinder.

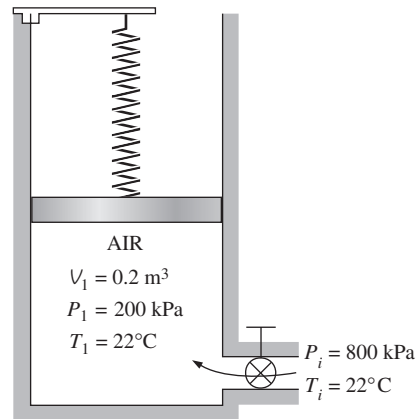

FIGURE P5–198

5–199 A piston–cylinder device initially contains 2 kg of refrigerant-134a at 800 kPa and 80°C. At this state, the piston is touching on a pair of stops at the top. The mass of the piston is such that a 500-kPa pressure is required to move it. A valve at the bottom of the tank is opened, and R-134a is withdrawn from the cylinder. After a while, the piston is observed to move and the valve is closed when half of the refrigerant is withdrawn from the tank and the temperature in the tank drops to 20°C. Determine (a) the work done and (b) the heat transfer. *Answers: (a) 11.6 kJ, (b) 60.7 kJ*

5–200 The pump of a water distribution system is powered by a 15-kW electric motor whose efficiency is 90 percent. The water flow rate through the pump is 50 L/s. The diameters of the inlet and outlet pipes are the same, and the elevation difference across the pump is negligible. If the pressures at the inlet and outlet of the pump are measured to be 100 kPa and 300 kPa (absolute), respectively, determine (a) the mechanical efficiency of the pump and (b) the temperature rise of water as it flows through the pump due to the mechanical inefficiency. *Answers: (a) 74.1 percent, (b) 0.017°C*

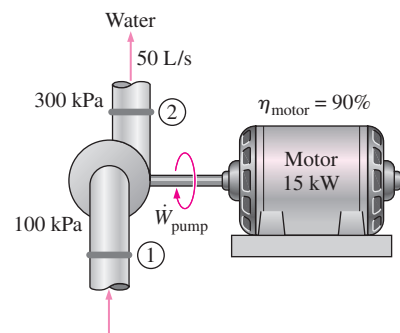

FIGURE P5–200

5–201 Steam enters a nozzle with a low velocity at 150°C and 200 kPa, and leaves as a saturated vapor at 75 kPa. There is a heat transfer from the nozzle to the surroundings in the amount of 26 kJ for every kilogram of steam flowing through the nozzle. Determine (a) the exit velocity of the steam and (b) the mass flow rate of the steam at the nozzle entrance if the nozzle exit area is 0.001 m².

5–202 The turbocharger of an internal combustion engine consists of a turbine and a compressor. Hot exhaust gases flow through the turbine to produce work and the work output from the turbine is used as the work input to the compressor. The pressure of ambient air is increased as it flows through the compressor before it enters the engine cylinders. Thus, the purpose of a turbocharger is to increase the pressure of air so that more air gets into the cylinder. Consequently, more fuel can be burned and more power can be produced by the engine.

In a turbocharger, exhaust gases enter the turbine at 400°C and 120 kPa at a rate of 0.02 kg/s and leave at 350°C and 120 kPa. Air enters the compressor at 50°C and 100 kPa and leaves at 130 kPa at a rate of 0.018 kg/s. The compressor increases the air pressure with a side effect: It also increases the air temperature, which increases the possibility of a gasoline engine to experience an engine knock. To avoid this, an aftercooler is placed after the compressor to cool the warm air by cold ambient air before it enters the engine cylinders. It is estimated that the aftercooler must decrease the air temperature below 80°C if knock is to be avoided. The cold ambient air enters the aftercooler at 30°C and leaves at 40°C. Disregarding any frictional losses in the turbine and the compressor and treating the exhaust gases as air, determine (a) the temperature of the air at the compressor outlet and (b) the minimum volume flow rate of ambient air required to avoid knock.

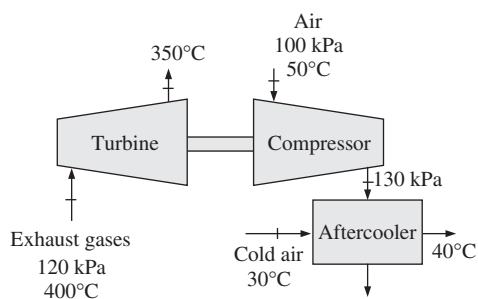

FIGURE P5–202

Fundamentals of Engineering (FE) Exam Problems

5–203 Steam is accelerated by a nozzle steadily from a low velocity to a velocity of 210 m/s at a rate of 3.2 kg/s. If the temperature and pressure of the steam at the nozzle exit are 400°C and 2 MPa, the exit area of the nozzle is

- (a) 24.0 cm² (b) 8.4 cm²
 (c) 10.2 cm² (d) 152 cm²
 (e) 23.0 cm²

5–204 Steam enters a diffuser steadily at 0.5 MPa, 300°C, and 122 m/s at a rate of 3.5 kg/s. The inlet area of the diffuser is

- (a) 15 cm² (b) 50 cm²
 (c) 105 cm² (d) 150 cm²
 (e) 190 cm²

5–205 An adiabatic heat exchanger is used to heat cold water at 15°C entering at a rate of 5 kg/s by hot air at 90°C entering also at a rate of 5 kg/s. If the exit temperature of hot air is 20°C, the exit temperature of cold water is

- (a) 27°C (b) 32°C
 (c) 52°C (d) 85°C
 (e) 90°C

5–206 A heat exchanger is used to heat cold water at 15°C entering at a rate of 2 kg/s by hot air at 100°C entering at a rate of 3 kg/s. The heat exchanger is not insulated and is losing heat at a rate of 40 kJ/s. If the exit temperature of hot air is 20°C, the exit temperature of cold water is

- (a) 44°C (b) 49°C
 (c) 39°C (d) 72°C
 (e) 95°C

5–207 An adiabatic heat exchanger is used to heat cold water at 15°C entering at a rate of 5 kg/s by hot water at 90°C entering at a rate of 4 kg/s. If the exit temperature of hot water is 50°C, the exit temperature of cold water is

- (a) 42°C (b) 47°C
 (c) 55°C (d) 78°C
 (e) 90°C

5–208 In a shower, cold water at 10°C flowing at a rate of 5 kg/min is mixed with hot water at 60°C flowing at a rate of 2 kg/min. The exit temperature of the mixture is

- (a) 24.3°C (b) 35.0°C
 (c) 40.0°C (d) 44.3°C
 (e) 55.2°C

5–209 In a heating system, cold outdoor air at 10°C flowing at a rate of 6 kg/min is mixed adiabatically with heated air at 70°C flowing at a rate of 3 kg/min. The exit temperature of the mixture is

- (a) 30°C (b) 40°C
 (c) 45°C (d) 55°C
 (e) 85°C

5–210 Hot combustion gases (assumed to have the properties of air at room temperature) enter a gas turbine at 1 MPa and 1500 K at a rate of 0.1 kg/s, and exit at 0.2 MPa and 900 K. If heat is lost from the turbine to the surroundings at a rate of 15 kJ/s, the power output of the gas turbine is

- (a) 15 kW (b) 30 kW
 (c) 45 kW (d) 60 kW
 (e) 75 kW

5–211 Steam expands in a turbine from 4 MPa and 500°C to 0.5 MPa and 250°C at a rate of 1350 kg/h. Heat is lost

from the turbine at a rate of 25 kJ/s during the process. The power output of the turbine is

- (a) 157 kW (b) 207 kW
(c) 182 kW (d) 287 kW
(e) 246 kW

5-212 Steam is compressed by an adiabatic compressor from 0.2 MPa and 150°C to 0.8 MPa and 350°C at a rate of 1.30 kg/s. The power input to the compressor is

- (a) 511 kW (b) 393 kW
(c) 302 kW (d) 717 kW
(e) 901 kW

5-213 Refrigerant-134a is compressed by a compressor from the saturated vapor state at 0.14 MPa to 1.2 MPa and 70°C at a rate of 0.108 kg/s. The refrigerant is cooled at a rate of 1.10 kJ/s during compression. The power input to the compressor is

- (a) 5.54 kW (b) 7.33 kW
(c) 6.64 kW (d) 7.74 kW
(e) 8.13 kW

5-214 Refrigerant-134a expands in an adiabatic turbine from 1.2 MPa and 100°C to 0.18 MPa and 50°C at a rate of 1.25 kg/s. The power output of the turbine is

- (a) 46.3 kW (b) 66.4 kW
(c) 72.7 kW (d) 89.2 kW
(e) 112.0 kW

5-215 Refrigerant-134a at 1.4 MPa and 90°C is throttled to a pressure of 0.6 MPa. The temperature of the refrigerant after throttling is

- (a) 22°C (b) 56°C
(c) 82°C (d) 80°C
(e) 90°C

5-216 Air at 20°C and 5 atm is throttled by a valve to 2 atm. If the valve is adiabatic and the change in kinetic energy is negligible, the exit temperature of air will be

- (a) 10°C (b) 14°C
(c) 17°C (d) 20°C
(e) 24°C

5-217 Steam at 1 MPa and 300°C is throttled adiabatically to a pressure of 0.4 MPa. If the change in kinetic energy is negligible, the specific volume of the steam after throttling is

- (a) 0.358 m³/kg (b) 0.233 m³/kg
(c) 0.375 m³/kg (d) 0.646 m³/kg
(e) 0.655 m³/kg

5-218 Air is to be heated steadily by an 8-kW electric resistance heater as it flows through an insulated duct. If the air enters at 50°C at a rate of 2 kg/s, the exit temperature of air is

- (a) 46.0°C (b) 50.0°C
(c) 54.0°C (d) 55.4°C
(e) 58.0°C

5-219 Saturated water vapor at 50°C is to be condensed as it flows through a tube at a rate of 0.35 kg/s. The condensate leaves the tube as a saturated liquid at 50°C. The rate of heat transfer from the tube is

- (a) 73 kJ/s (b) 980 kJ/s
(c) 2380 kJ/s (d) 834 kJ/s
(e) 907 kJ/s

Design and Essay Problems

5-220 Pneumatic nail drivers used in construction require 0.02 ft³ of air at 100 psia and 1 Btu of energy to drive a single nail. You have been assigned the task of designing a compressed-air storage tank with enough capacity to drive 500 nails. The pressure in this tank cannot exceed 500 psia, and the temperature cannot exceed that normally found at a construction site. What is the maximum pressure to be used in the tank and what is the tank's volume?

5-221 You have been given the responsibility of picking a steam turbine for an electrical-generation station that is to produce 300 MW of electrical power that will sell for \$0.05 per kilowatt-hour. The boiler will produce steam at 700 psia and 700°F, and the condenser is planned to operate at 80°F. The cost of generating and condensing the steam is \$0.01 per kilowatt-hour of electricity produced. You have narrowed your selection to the three turbines in the table below. Your criterion for selection is to pay for the equipment as quickly as possible. Which turbine should you choose?

Turbine	Capacity (MW)	η	Cost (\$Million)	Operating Cost (\$/kWh)
A	50	0.9	5	0.01
B	100	0.92	11	0.01
C	100	0.93	10.5	0.015

5-222E You are to design a small, directional control rocket to operate in space by providing as many as 100 bursts of 5 seconds each with a mass flow rate of 0.5 lbm/s at a velocity of 400 ft/s. Storage tanks that will contain up to 3000 psia are available, and the tanks will be located in an environment whose temperature is 40°F. Your design criterion is to minimize the volume of the storage tank. Should you use a compressed-air or an R-134a system?

5-223 An air cannon uses compressed air to propel a projectile from rest to a final velocity. Consider an air cannon that is to accelerate a 10-gram projectile to a speed of 300 m/s using compressed air, whose temperature cannot exceed 20°C. The volume of the storage tank is not to exceed 0.1 m³. Select the storage volume size and maximum storage pressure that requires the minimum amount of energy to fill the tank.

5-224 To maintain altitude, the temperature of the air inside a hot-air balloon must remain within a 1°C band, while the

volume cannot vary by more than 1 percent. At a 300-m altitude, the air in a 1000 m^3 hot-air balloon needs to maintain a 35°C average temperature. This balloon loses heat at a rate of 3 kW through the fabric. When the burner is activated, it adds 30 kg/s of air at 200°C and 100 kPa to the balloon. When the

flap that allows air to escape is opened, air leaves the balloon at a rate of 20 kg/s. Design the burner and exhaust-flap control cycles (on time and off time) necessary to maintain the balloon at a 300-m altitude.

