

NAME: _____ STUDENT NUMBER: _____

SECTION: _____

CARLETON UNIVERSITY

MAAE 2300: Fluid Mechanics I
22 HR TAKE-HOME MID-TERM ASSIGNMENT
February 12, 2014

Department Name: Mechanical and Aerospace Engineering

Course Number: **MAAE 2300 Fluid Mechanics I**

Instructors: J. Gaydos (Section B), D. Feszty (Section C), O. Petel (Section D), V. Tang (Section F)

INSTRUCTIONS – READ CAREFULLY:

This is an **individual** assignment. You may not collaborate with any other individual, or plagiarise their work. Suspected collaboration or plagiarism will be dealt with according to Carleton University's Academic Integrity Policy.

The midterm assignment consists of theory based multiple choice questions as well as some that require calculations. You may use the course textbook and any material posted on CULearn, including course notes and PA questions, to answer the midterm assignment. All other written materials are forbidden, as are any other electronic materials.

Given that this is a take-home exam, answers are expected to be quite thorough. Depending on your speed and skill, it is estimated that this exam should take you approximately three hours to complete. You may not work with other students on your answers. Answers must be clearly written and complete. If you have doubts about the meaning or completeness of a question, supply the material you believe you need to answer the question and state your assumptions at the beginning of your answer. Show all your work. Unless a problem explicitly states "no explanation required", please try to write as detailed an explanation as possible. Answers to questions without justifications will be counted as wrong. **Show your final answer in the table shown on the 2nd page.** Finally, in your solution, you will need to add references to your property tables (textbook and table number) if they are required to solve a question.

The midterm assignment is **due on Thursday, February 13th at 4:00 pm**. The exam shall be dropped off in a marked drop box at the Mechanical and Aerospace Engineering (MAE) Office (room ME 3135). Please note that the MAE Office is open from 8:30 am – 4:30 pm on weekdays and is closed during lunch hour from 12:00 pm - 1:00 pm. Print and staple the entire midterm booklet. This booklet has 12 pages. Late midterms will not be accepted under any circumstances. Midterms submitted in class or via email will not be accepted.

During the 22 hour period, the professors and TAs will not be available to answer any questions about the midterm. Remember, if you have any doubts about the meaning of a question, state your assumptions and proceed.

HONOUR STATEMENT:

I have neither given nor received any help on this exam, and I have not discussed the exam with anyone. I attest that all of the answers are my own work. My signature below indicates that I neither gave nor received unauthorized assistance on this assignment.

Student Printed Name

Student Signature

NAME: _____ STUDENT NUMBER: _____

SECTION	Questions	Value of Each Question	Total
Section 1: Multiple Choice Questions (no explanation required)	1-16	1.5 mark	24 marks
Section 2: Multiple Choice Questions (full solution required)	17-27	2 or 3 marks (each problem is worth 6 marks)	24 marks
		TOTAL	48 marks

MULTIPLE CHOICE ANSWER SHEET

- Please circle your final answers below.
- For Questions 1-16, no explanation is required.
- For Questions 17-27, only those answers will be counted, for which you provide a full solution.
- No part marks will be given.

Question no.:	Answer (circle your final answer)						Marks
1	a	b	c	d	e	f	1.5
2	a	b	c	d	e	f	1.5
3	a	b	c	d	e	f	1.5
4	a	b	c	d	e	f	1.5
5	a	b	c	d	e	f	1.5
6	a	b	c	d	e	f	1.5
7	a	b	c	d	e	f	1.5
8	a	b	c	d	e	f	1.5
9	a	b	c	d	e	f	1.5
10	a	b	c	d	e	f	1.5
11	a	b	c	d	e	f	1.5
12	a	b	c	d	e	f	1.5
13	a	b	c	d	e	f	1.5
14	a	b	c	d	e	f	1.5
15	a	b	c	d	e	f	1.5
16	a	b	c	d	e	f	1.5
17	a	b	c	d	e	f	2
18	a	b	c	d	e	f	2
19	a	b	c	d	e	f	2
20	a	b	c	d	e	f	3
21	a	b	c	d	e	f	3
22	a	b	c	d	e	f	2
23	a	b	c	d	e	f	2
24	a	b	c	d	e	f	2
25	a	b	c	d	e	f	2
26	a	b	c	d	e	f	2
27	a	b	c	d	e	f	2

TOTAL MARKS:

/48

SECTION 1: MULTIPLE CHOICE QUESTIONS

(no explanation required)

Please indicate your answer on the Multiple Choice Answer Sheet on page 2.

Question 1

Incompressible fluid means that:

- a) the pressure is equal and constant at every point in the fluid
- b) the density is equal and constant at every point in the fluid
- c) although the density is different at various points in the fluid, it is constant at these points, i.e. it does not change with time.

Question 2

Unsteady (or non-stationary) flow means that:

- a) the fluid properties (such as velocity, pressure, density, etc.) vary in space, i.e. between two points, such as cross sections A_1 and A_3 in the figure below
- b) the fluid properties (such as velocity, pressure, density, etc.) do not vary in space, i.e. between two points, such as cross sections A_1 and A_3 in the figure below
- c) the fluid properties (such as velocity, pressure, density, etc.) vary in time at a given point, such as cross section A_1 in the figure below
- d) the fluid properties (such as velocity, pressure, density, etc.) do not vary in time at a given point, such as cross section A_1 in the figure below

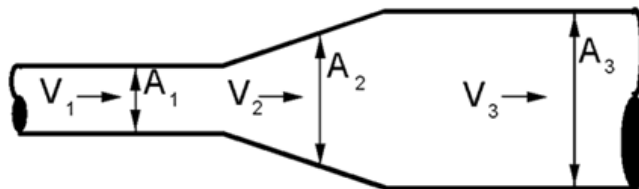

Question 3

A streamline is defined as:

- a) a line defining the path of a given particle of fluid (for example: recording the positions of a floating cork on the surface of a river)
- b) traces made by a dye or smoke injected at a given point in the flowfield (e.g. smoke tunnel visualization)
- c) a line to which velocity vectors are tangential at all points along itself

Question 4

For the Control Volume approach,

- a) we need to know the fluid properties (such as velocity, pressure, density) at every point inside the Control Volume
- b) we need to know the fluid properties (such as velocity, pressure, density) along the Control Surface only, i.e. there is no need to know the fluid properties inside the Control Volume.
- c) we need to know the fluid properties (such as velocity, pressure, density) at every point inside the Control Volume as well as along the Control Surface as well.

Question 5

On the surface of the Lake Ontario, the water pressure is:

- a) larger than the atmospheric pressure, and equal to $p = \rho \cdot g \cdot z$, where z is the depth of water below a particular point
- b) less than the atmospheric pressure
- c) equal to the local atmospheric pressure
- d) equal to the mean seasonal atmospheric pressure
- e) equal to zero (absolute) pressure

Question 6

When a fluid moves past a solid stationary wall, the speed of the fluid changes with distance from the solid wall. However, the fluid adjacent to the wall is also stationary. This condition is known as:

- a) The stationary condition
- b) The no slide condition
- c) The no slip condition
- d) The no shear stress condition
- e) The solid wall principle of flow

Question 7

When Sun rise occurs on the Moon the pressure increases near the Moon's surface because of photon effects and lunar rock out-gassing. If we measure the pressure as a gauge pressure (where gauge is related to the ambient sea-level pressure on Earth and not on the Moon), then we would expect a value that is:

- a) Slightly below 100 kPa,
- b) Slightly above 0 kPa,
- c) Slightly below 0 kPa,
- d) Slightly above -100 kPa, or
- e) Slightly below -100 kPa.

Question 8

A gauge pressure can be given using the height of any fluid. This vertical height is the 'head' and if pressure is quoted in head, then the density of the fluid must also be given. Estimate a 500 kNm^{-2} pressure in head of mercury. Your answer is closest to:

- a) 51.0 m
- b) 37.5 m
- c) 5.1 m
- d) 3.8 m
- e) 0.4 m

Question 9

A gauge pressure can be given using the height of any fluid. This vertical height is the 'head' and if pressure is quoted in head, then the density of the fluid must also be given. Estimate the pressure corresponding to 500 kNm^{-2} in head of air (assuming air is compressible and that it has a constant temperature of 15°C). Your answer is closest to:

- a) 16,000 m
- b) 5,100 m
- c) 3,800 m
- d) 700 m
- e) 510 m

Question 10

After an exhausting first few weeks of school you decide to get away and board the train for the bright lights and action of Toronto. As you sit down trying to decide where to go with your beverage held horizontal on the table in front of your seat, you decide to let the forward acceleration of the train tilt the fluid into your mouth. You know from fluid mechanics that the train's acceleration will save you the effort of tilting your beverage. If the cup has a diameter of 6 cm and the liquid is 1 cm below the top edge (or lip) of the cup, then what train acceleration will shift the liquid upwards towards the cup's edge without spilling any liquid. Your answer is closest to:

- a) 0.06 m/s^2
- b) 0.2 m/s^2
- c) 1.7 m/s^2
- d) 3.5 m/s^2
- e) 7.5 m/s^2

Question 11

If the density of oil and glycerine is 917 kg/m^3 and $1,258 \text{ kg/m}^3$, respectively, than what is the relationship between the pressures at point A and B for the figure shown below? Note that the density of water is $1,000 \text{ kg/m}^3$.

- a) $p_A < p_B$
- b) $p_A > p_B$
- c) $p_A = p_B$
- d) Not enough information to come to a solution

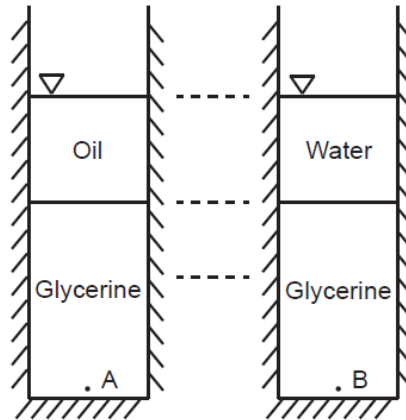

Question 12

What is the relationship between the force acting on the bases of containers A and B?

- a) $F_A = F_B$
- b) $1.5F_A = F_B$
- c) $5F_A = F_B$
- d) $3.3 F_A = F_B$

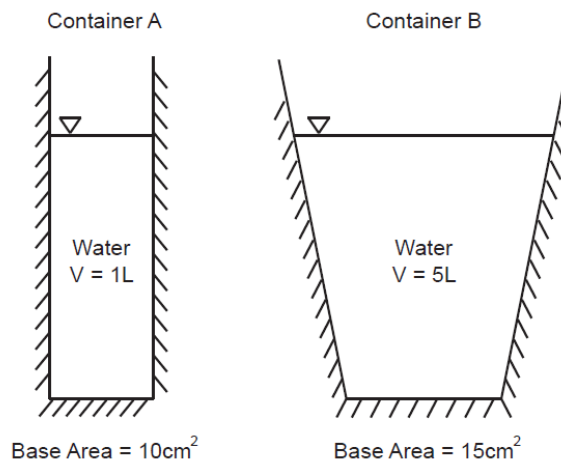

Question 13

If the density of oil and water is 917 kg/m^3 and $1,000 \text{ kg/m}^3$, respectively, than what is the relationship between the pressures at point A and B?

- a) $p_A < p_B$
- b) $p_A > p_B$
- c) $p_A = p_B$
- d) Not enough information to come to a solution

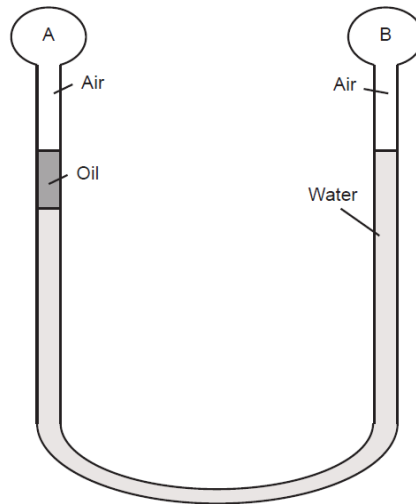

Question 14

How will the force exerted on the diaphragm change as a result of spinning the u-tube with a constant angular velocity?

- a) The force will increase
- b) The force will decrease
- c) No difference, the force will remain the same
- d) Not enough information to come to a solution

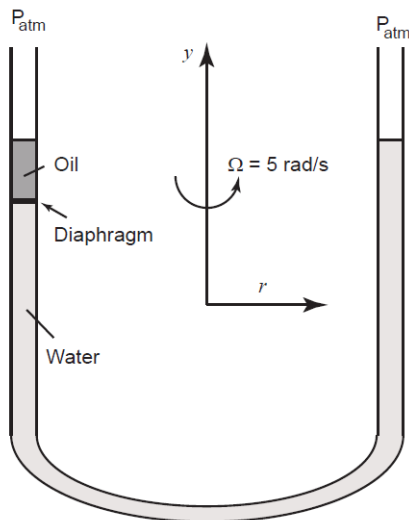

Question 15

How will the force exerted on the diaphragm change as a result of spinning the u-tube with a constant angular velocity?

- a) The force will increase in magnitude
- b) The force will decrease and may even switch directions across the diaphragm
- c) No difference, the force will remain the same
- d) Not enough information to come to a solution

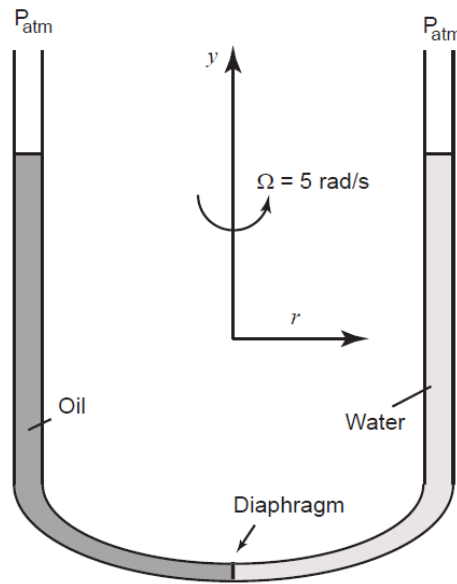

Question 16

When a fluid is accelerated in a translational motion, such as shown in the figure below, then,

- a) the pressure at point A is larger than at point B, since it sits on a higher "column" of liquid
- b) the pressure at point A is lower than at point B, since it is located higher than point B
- c) the pressures at points A and B are equal

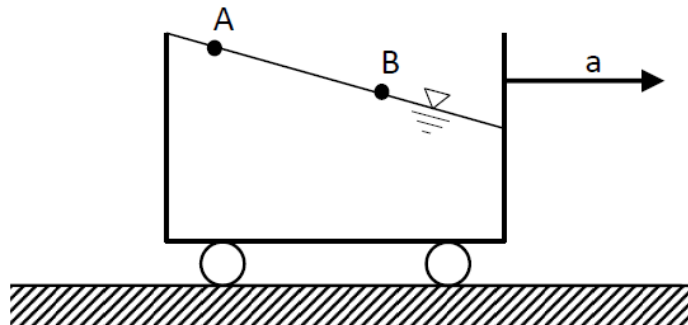

SECTION 2: MULTIPLE CHOICE QUESTIONS
(full solution required)

For Questions 17, 18, please refer to the problem statement below. Please indicate your answers on the Multiple Choice Answer Sheet on page 2.

Problem Statement: A 2 mm internal diameter U-tube containing water is initially sealed on one end. A 10 mL volume of ethyl alcohol is added to the tube through the open end as shown in the figure below. The tube is maintained at a temperature of 20° C.

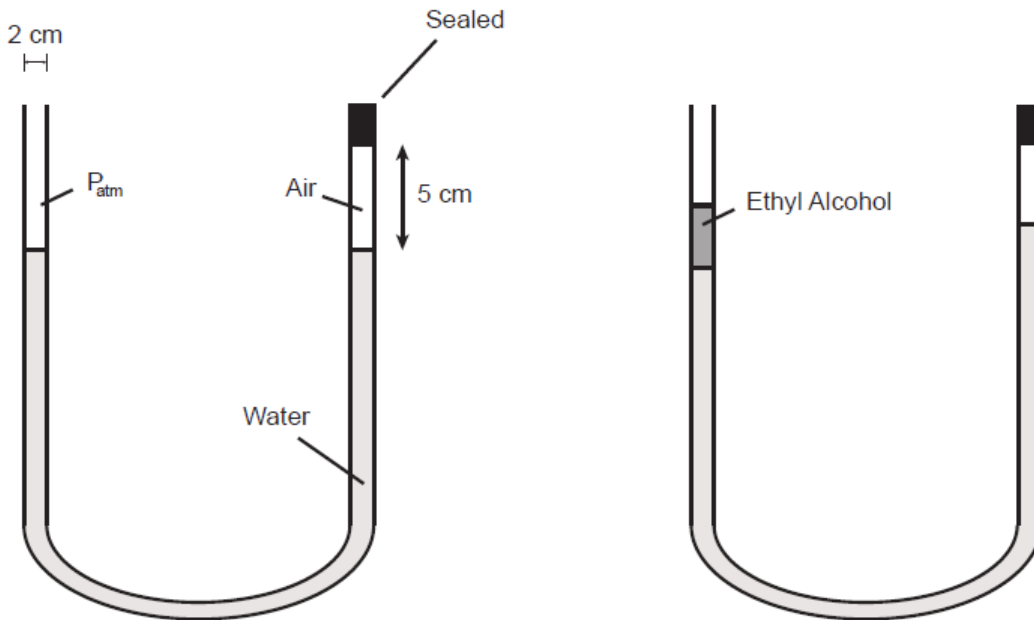

Question 17

What is the height difference between the water levels in the manometer?

- a) 0.24 mm
- b) 0.72 mm
- c) 2.4 mm
- d) 7.2 mm

Question 18

What is the height difference between the water levels if the seal is removed?

- a) 0.13 cm
- b) 1.30 cm
- c) 0.25 cm
- d) 2.50 cm

For Questions 19, 20 and 21, please refer to the problem statement below. Please indicate your answers on the Multiple Choice Answer Sheet on page 2.

Problem Statement: Consider a tank filled with mercury at 20 °C ($\rho = 13,550 \text{ kg/m}^3$) and accelerating while rolling up a 35° inclined plane, as shown in the figure below. Assuming rigid body motion, answer the following questions:

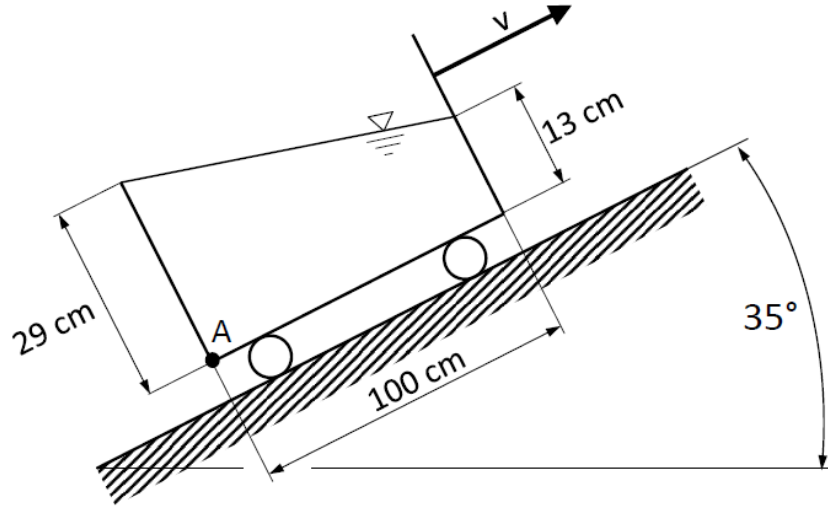

Question 19

The absolute value (i.e. the magnitude) of the tank's acceleration is:

- a) 4.34 m/s²
- b) 5.82 m/s²
- c) 8.82 m/s²

Question 20

The tank is:

- a) accelerating
- b) decelerating
- c) moving with a constant velocity

Question 21

The pressure at point A is:

- a) 38,548 Pa
- b) 35,114 Pa
- c) 31,576 Pa

NAME: _____ STUDENT NUMBER: _____

For Questions 22, 23, 24, please refer to the problem statement below. Please indicate your answers on the Multiple Choice Answer Sheet on page 2.

Problem Statement: A rigid tank of volume 1 m^3 is initially filled with air at 20°C and 100 kPa . At the start of, time $t = 0$, a vacuum pump is turned on and begins to evacuate air at a contact volume flow rate of 80 L/min (rate is independent of the tank's pressure). Assume an ideal gas and an isothermal (constant temperature) evacuation and:

Question 22

Set-up a differential equation for mass flow out of the tank. This should be of the form:

a) $V \frac{d\rho}{dt} + \rho Q = 0$

where ρ is the air's density at any time, V is the tank's volume and Q is the volume flow rate out-off the tank

b) $m(t) = m_0 - \frac{dm}{dt} t$

where m_0 is the initial mass of air within the tank and $m(t)$ is its value at any time after the pump has been started

c) $\frac{d}{dt}(\rho Q) + \rho Q = 0$

where ρ is the air's density at any time and Q is the volume flow rate out-off the tank

Question 23

Solve this equation for the time t as a function of the tank volume V , gas volume flow rate Q , initial tank pressure p and the final tank pressure p_0 . The answer should be in the form:

a) $t = -\frac{V}{Q} \ln\left(\frac{p}{p_0}\right)$

b) $t = \frac{V}{Q} \left(\frac{p}{p_0} - 1\right)$

c) $t = -\frac{V}{Q} \ln\left(\frac{pQ}{RT}\right)$

Question 24

The time (in seconds) to pump the tank down to a pressure of $p = 20 \text{ kPa}$ would be:

a) 1,200 s

b) 3,000 s

c) 200 s

NAME: _____ STUDENT NUMBER: _____

For Questions 25, 26, 27 please refer to the problem statement below. Please indicate your answers on the Multiple Choice Answer Sheet on page 2.

Problem Statement: A 1 m diameter tank, having a mass of 50 kg when empty, is placed on a scale as shown in the figure. The tank is being filled with room-temperature water at the rate of 100 L/s, through an opening in the top. At the same time, water is draining from the tank through two small pipes of 10 cm in diameter, near the bottom. The diameter of the inflow jet is 20 cm.

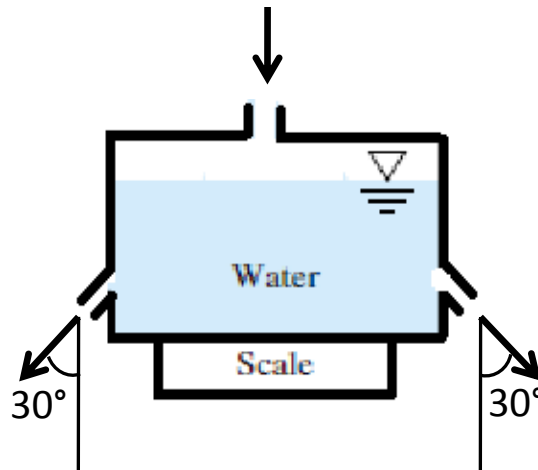

Assuming that the velocity of an outflow from a small pipe can be calculated from: $v = (2gh)^{1/2}$, where “h” is the depth of the water in the tank, and “g” is the gravitational acceleration, answer the following questions:

Question 25

When the volume of the water in the tank reaches 200 L, what would be the rate of change of the water level inside the tank:

- a) 0 cm/s
- b) 4.96 cm/s
- c) 8.3 cm/s
- d) 12.1 cm/s

Question 26

How much water has been accumulated in the tank by the time the steady state condition is reached (i.e. when the water level would remain unchanged)?

- a) 1,620 L
- b) 1,507 L
- c) 856 L
- d) 2,143 L

Question 27

At steady state flow, the scale reading would be closest to:

- a) 55 kg
- b) 762 kg
- c) 2,158 kg
- d) 1,648 kg