

Question 1

Under normal operating conditions, the electric motor exerts a torque of 3 kN.m at A, and $T_B = 1.5$ kN.m, $T_C = 1$ kN.m and $T_D = 0.5$ kN.m, respectively. Knowing that each segment of the shaft is solid and 0.75 m long, determine (a) the maximum shearing stress in shaft AE; and (b) the angle of twist of pulley D with respect to pulley B. Use $G = 70$ GPa.

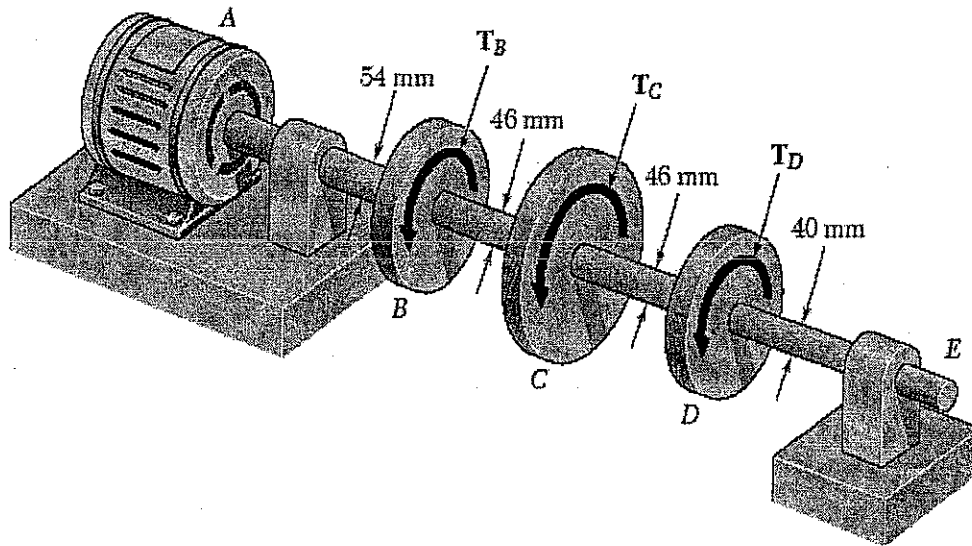

a) $\tau_{\max} = 97.0 \text{ MPa}$

b) $\phi = 0.04875 \text{ RADIANS}$
or 2.79°

Question 2

A load P is applied to the plate bolted to a support as shown. If the maximum allowable shearing stress in the bolts is 85 MPa, determine the maximum value of the load P . Determine also the maximum bearing stress on the plate. All bolts are 25 mm in diameter and the plate is 15 mm thick.

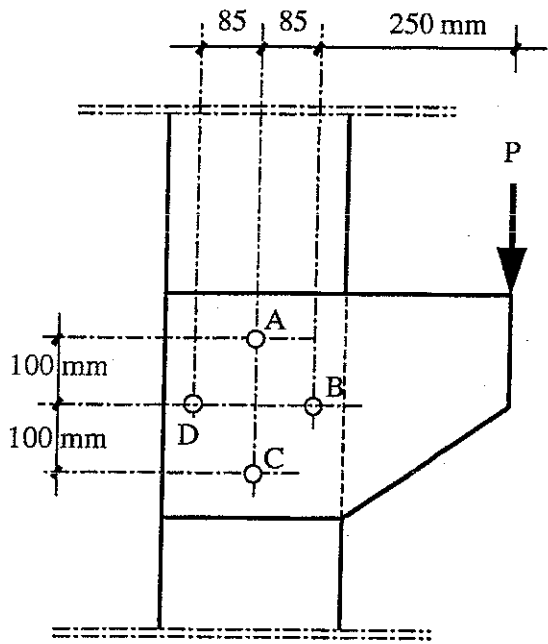

$P = 38.8 \text{ kN}$
 $\sigma_b = 111.3 \text{ MPa}$

Question 3

Draw the shear and beam moment diagrams for the loading shown and determine the maximum shear stress and maximum normal stress for the cross-section given.

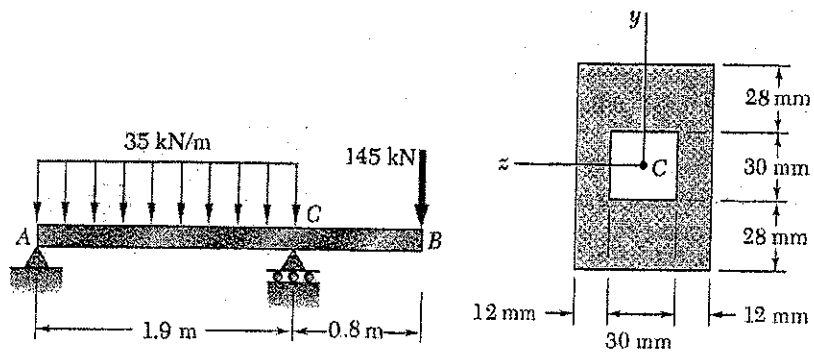

$\sigma_{max} = 1.785 \text{ GPa}$ $\tau_{max} = 100.6 \text{ MPa}$

Question 4

Two forces are applied at points A and B of the solid cast-iron bracket shown. Knowing that the bracket has a diameter of 20mm, determine the stresses at point H.

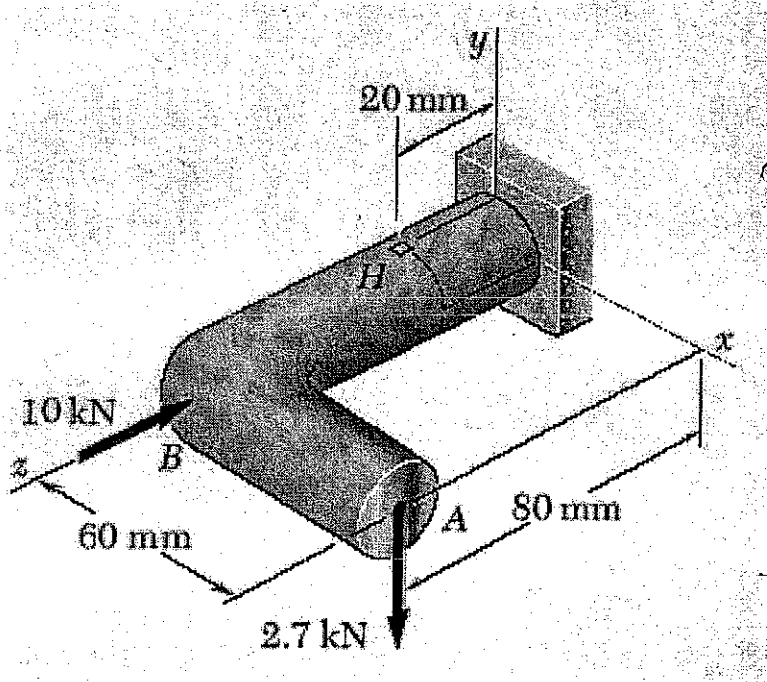

$\sigma_H = 174.5 \text{ MPa}$
 $\tau_H = 103.2 \text{ MPa}$

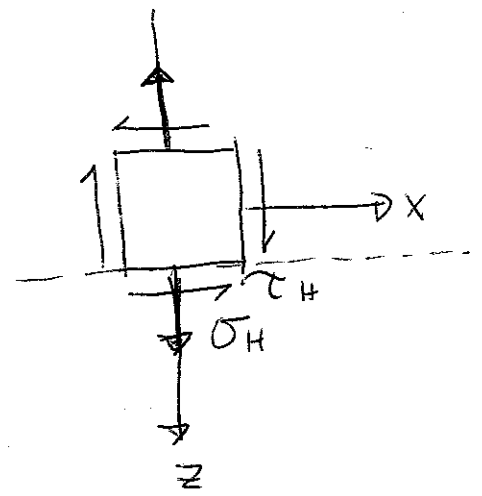

Question 5

For a plane state of stress it is known that the normal and shearing stresses are directed as shown and that $\sigma_x = 30 \text{ MPa}$, $\sigma_y = 80 \text{ MPa}$ and $\sigma_{\max} = 120 \text{ MPa}$. Determine using Mohr circle (a) the principal stress σ_{\min} , (b) the maximum shear stress τ_{\max} and (c) show the principal stresses and the maximum shear stresses on properly oriented element(s).

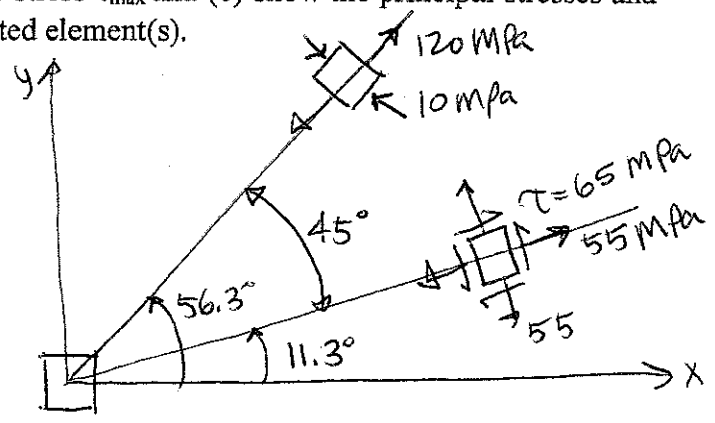
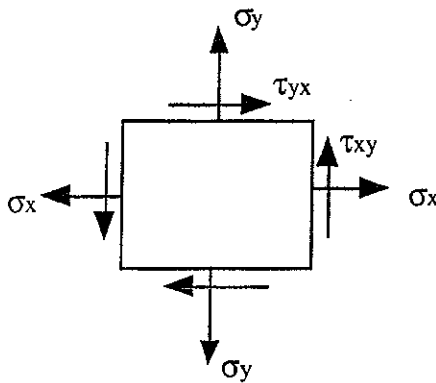

Question 6

Beam ABC carries uniformly distributed load w on BC and no load on AB. Find the rotation at B and the displacement at A in terms of w , L , E and I .

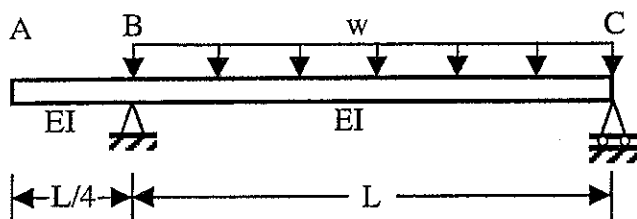

$$\theta_B = \frac{-wL^3}{24EI}$$

Question 7

$$y_A = \frac{L}{4} \sin\left(-\frac{wL^3}{24EI}\right)$$

- Write the expression of the critical load for each of the axially loaded columns of Fig. a in terms of E , I and L .
- A W310x74 steel section is used as a column as shown in Fig b. The column is assumed to have the end conditions at the top and bottom as shown, i. e. fixed at the base and pinned at the top in all directions. It is braced at mid-height to prevent movement in the x -direction only. Determine the column capacity using a factor of safety of 2.0 against elastic buckling.

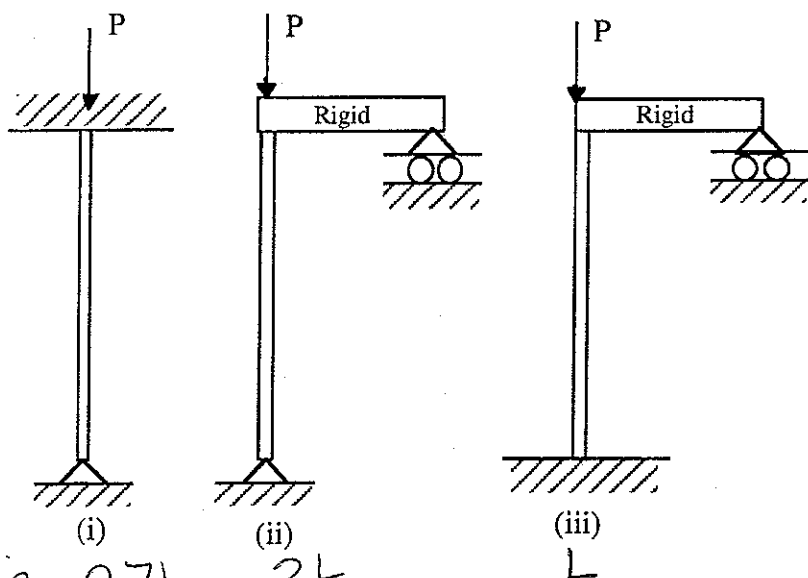

$$L_e = 0.7L$$

$$2L$$

Fig. a

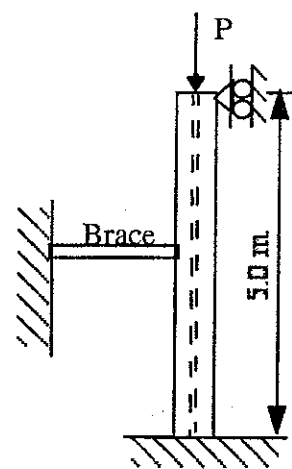

$$\begin{aligned} A &= 9480 \text{ mm} \\ I_x &= 165 \times 10^6 \text{ mm}^4 \\ I_y &= 23.4 \times 10^6 \text{ mm}^4 \\ E &= 200 \text{ GPa} \end{aligned}$$

Fig. b

$$P = 3.7 \times 10^6 \text{ N}$$