

BUSI 2301 D (Fall 2011)
Final Exam Review

1. Consider the linear programming below:

$$\begin{aligned} \text{Min } & 24X_1 + 4X_2 \\ \text{s. t. } & 5X_1 + 4X_2 \leq 2000 \\ & X_1 \geq 80 \\ & X_1 + X_2 \geq 300 \\ & X_2 \geq 100 \end{aligned}$$

Answer the following questions:

- a) Using graphical solution method to determine the optimum of X_1 and X_2 , and show the feasible solution space.
 - b) What is the value of the objective function?
 - c) Which constraints are binding and why?
2. Electronic Village stocks and sells a particular brand of personal computer. It costs the store \$450 each time it places an order with the manufacturer. The annual cost of carrying the PCs in inventory is \$170, and the annual demand for the PCs is estimated to be 1200 units. Determine the optimal order quantity and the total minimum inventory cost.
 3. Estimated annual demand of Cascade carpet, manufactured by Carpet World, is 20,000 yards of carpet with an annual carrying cost of \$2.75 per yard. The manufacturing facility operates 360 days each year and produces 400 yards of carpet per day. The setup cost for a production run is \$720. Determine the optimal run quantity, total inventory cost, the maximum inventory level, and the run length for the optimal run quantity.
 4. A manufacturing firm, maker of the No. 562 valves, has offered quantity discounts. The volumes and prices are:

Order Quantity	Unit Price
1-99	\$10.00
100 to 499	\$9.50
500 or more	\$9.00

The annual demand for the valves is 2000 units, the annual carrying cost is 35% of the unit price, and the ordering cost is \$30 order. Determine the true EOQ.

5. Using the given information, determine the following:

<u>Period</u>	<u>Forecast</u>
1	400
2	200
3	300
4	400
5	500
6	200

The costs for the production are as follows:

Regular time:	\$20 per unit (280 units per period maximum)
Overtime:	\$30 per unit (40 units per period maximum)
Subcontracting:	\$40 per unit (100 units per period maximum)
Beginning inventory:	40 units
Holding cost:	\$1 per unit per period
Backorder cost	\$5 per unit per period

Develop aggregate plan of production for the following two scenarios and show the steps of your calculation:

- use only overtime, allow back order; and
- use a combination of overtime and subcontracting, allow back order.

6. The following product structure tree shows the components needed to assemble one unit of product W. determine the quantities of each component needed to assemble 100 units of W.

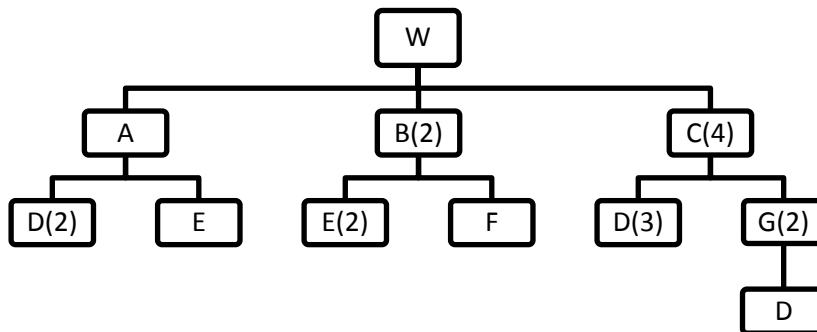

7. Consider an item that has projected requirements as shown in the following table. It has a beginning inventory of 35 units. The carrying cost is \$1 per week. The setup cost is \$100. The lead time to assemble the item is one week.

Period	1	2	3	4	5	6	7	8	9	10
Gross Requirement	35	30	40	-	10	40	30	-	30	55

Develop two solutions (two MRP tables) using EOQ and part period balancing lot-sizing techniques respectively.

8. Use the following information to create a product tree diagram (bill of materials) and develop a lot-for-lot materials requirement plan for product A. The gross requirements for product A are 250 units in week 4 and 100 units in week 6.

Item	Parent	Qty for 1 unit of parent	On-hand inventory	Scheduled receipt (week)	Lead time (week)	Lot size
A	-	-	100		1	200
B	A	1	-		2	500
C	A	2	300		1	300
D	C	3	100	2000 (2)	2	2000
E	C	1	50		1	500

9. Consider the following jobs, their processing times and due dates:

Job	Processing times (days)	Due date (days)
A	4	6
B	17	20
C	14	18
D	9	13
E	11	12

Assume that jobs arrived in the alphabetical order. Determine the sequence of jobs, the average flow time, average days late, and average WIP for each of the following rules:

- a. Shortest processing time (SPT)
- b. Earliest due date (EDD)
- c. Minimum slack time (MST)
- d. Critical ration (CR)

10. A body and paint shop has five cars to schedule for repair. Each car requires body work (station 1) prior to painting (station 2). The estimates of the times required to do the work at each of the two stations are as follows:

CAR	BODY WORK (STATION 1) (hours)	PAINT (STATION 2) (hours)
A	10	2
B	5	4
C	7	5
D	3	6
E	1	7

- a) Determine the optimum sequence to schedule the cars.
- b) What is the makespan for the optimal schedule?
- c) What is the idle time for the optimal schedule?