

SOIL MECHANICS II
CIVL 311
COURSE NOTES
2012

Module 8 – Segment C
Design of Deep Foundations

Instructor: Dr. D. Wijewickreme, P. Eng.
Department of Civil Engineering
University of British Columbia
Vancouver, B.C.
Canada



Module 8

Design of Deep Foundations

Overall Learning Objectives

- Introduction – Deep Foundations (Book 2 pp. 274 - 280)
- Ultimate Limit State – load capacity of single piles (Book 2 pp. 280 – 297, 313 - 316)
- Serviceability Limit State – settlement of piles and pile groups (Book 2 pp. 298 – 313)
- Lateral Loading of Piles (Book 2 pp. 317 – 323)
- Design Issues and Procedures (Book 2 pp. 324 – 332)

SOIL MECHANICS II

CIVL 311

COURSE NOTES

Load Capacity of Pile Groups



Instructor: Dr. D. Wijewickreme, P. Eng.
Department of Civil Engineering
University of British Columbia
Vancouver, B.C.
Canada

Selection of foundation scheme

Low Weight

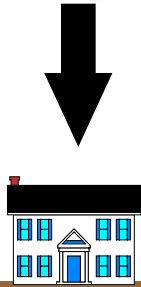

Large Distributed Weight

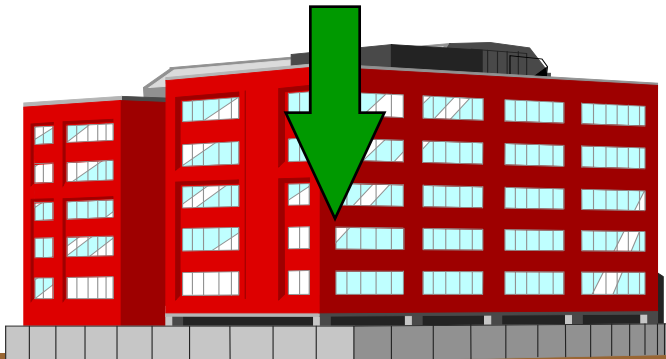

Very Large Concentrated Weight



Soft to Firm Clay

Dense Sand

Strong Rock

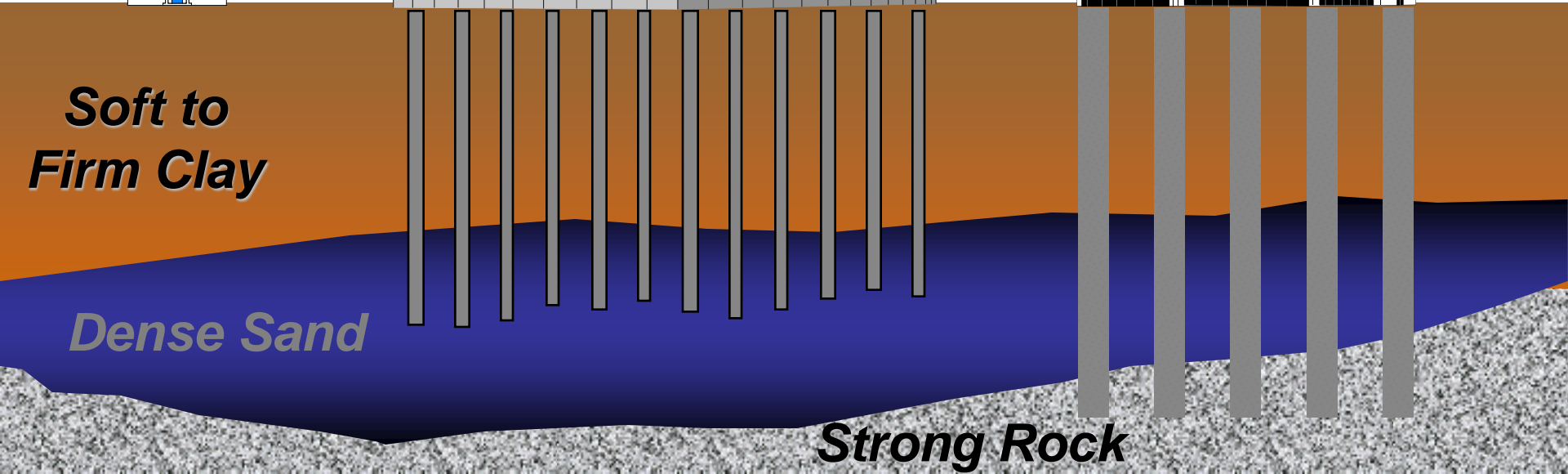

Pile Cap

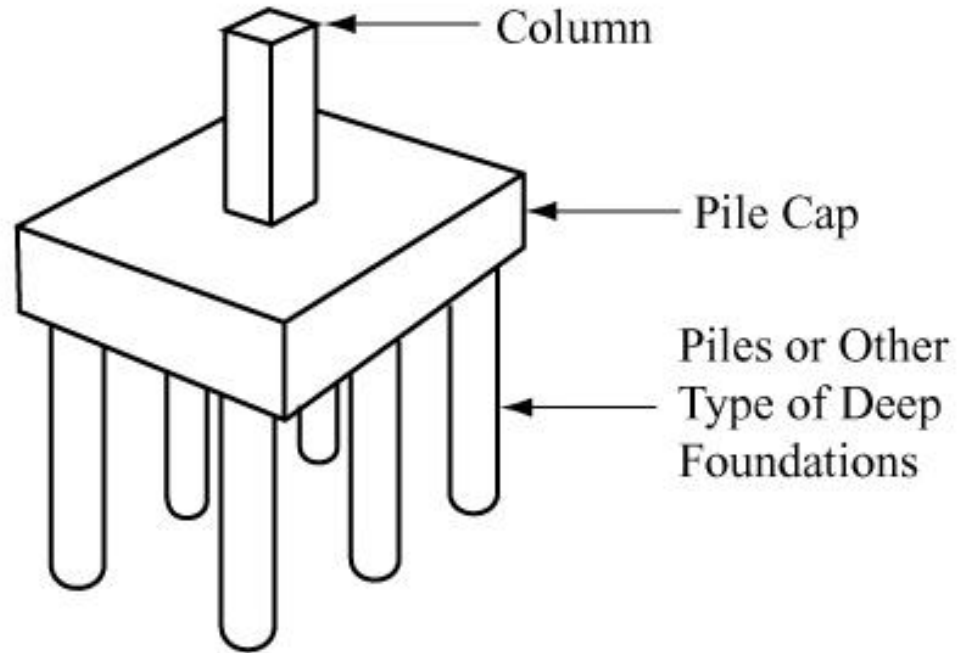

A pile cap is a structural member that connects the piles in a group.

Design of pile groups

- Group capacity
- Effect of pile cap
- Group settlement

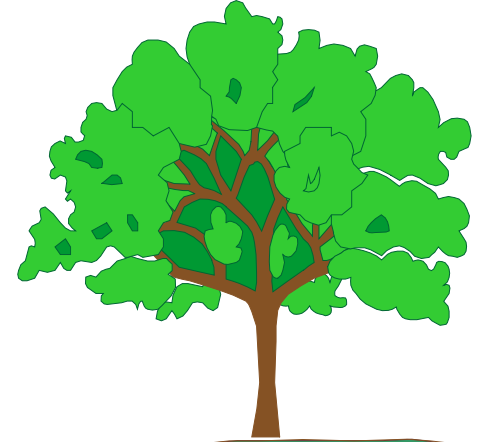
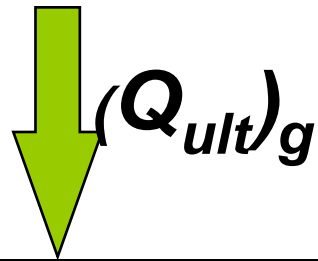

Pile Cap

- ***Overlapping stress fields***
- ***Progressive densification***
- ***Progressive loosening***
- ***Case-by-case basis***

$$(Q_{ult})_g \neq n \cdot Q_{ult}$$

$$\eta_e = (Q_{ult})_g / n \cdot Q_{ult}$$

Group efficiency-depends on

- Number, length, diameter, arrangement and spacing of piles
 - (Typical centre to centre pile spacing = $2.5D$ to $3D$)
- Installation procedures and sequence
- Side friction vs. end-bearing
- Elapsed time since installation
- Effect of pile cap
- Direction of applied load

Pile Group Failure Modes

– BLOCK FAILURE

Pile layout matrix = $m \times n$

$$\text{Area} = [(m-1)s + D] [(n-1)s + D]$$

$$\text{Perimeter} = 2[(m-1)s + D] + 2[(n-1)s + D]$$

Where, s = centre to centre pile spacing

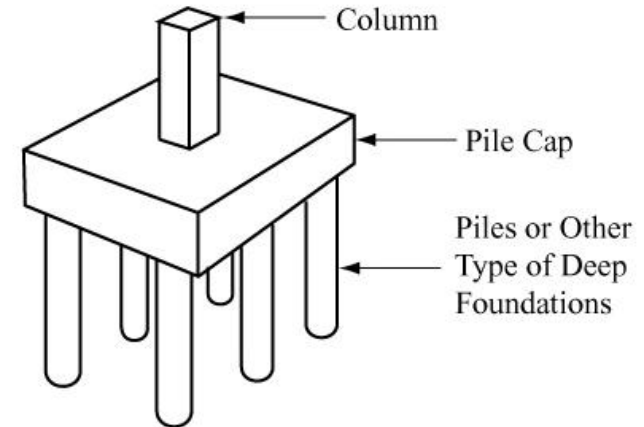

– AS A MULTIPLE OF SINGLE PILE FAILURE

$$\text{Ultimate load} = mn (Q_{\text{ult}})_{\text{single pile}}$$

The expressions for the bearing capacities for ESA and TSA are the same as those for single piles except the perimeter and area are different.

Bearing Capacity of Pile Group – Block Failure in Clay

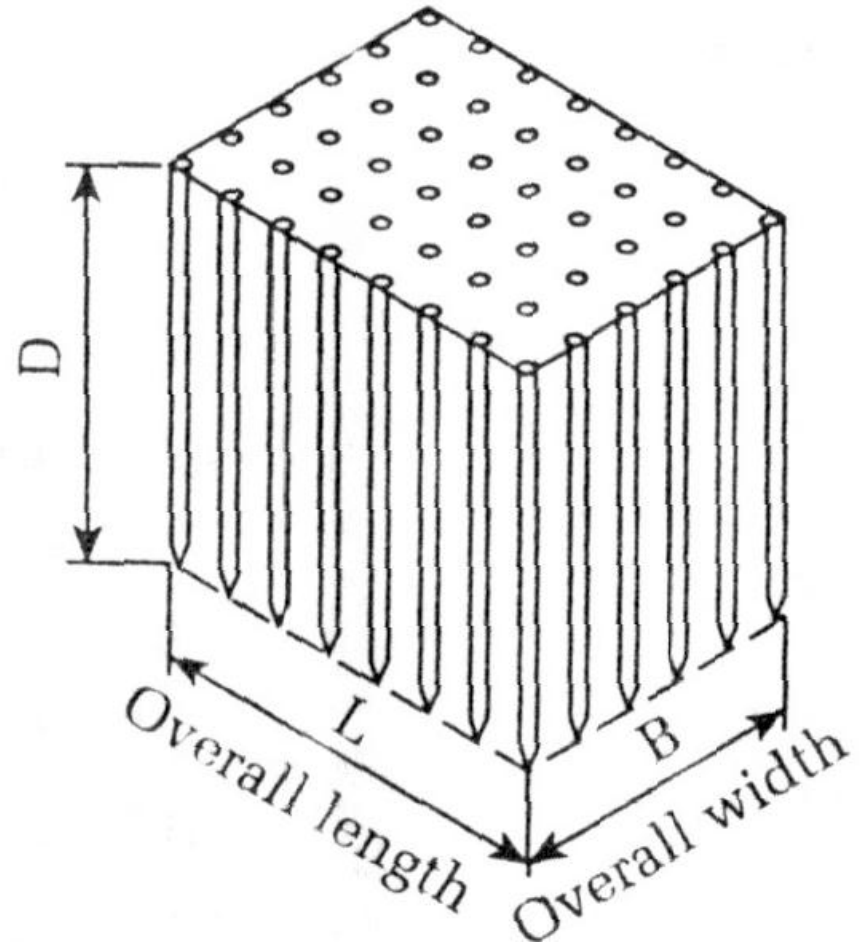
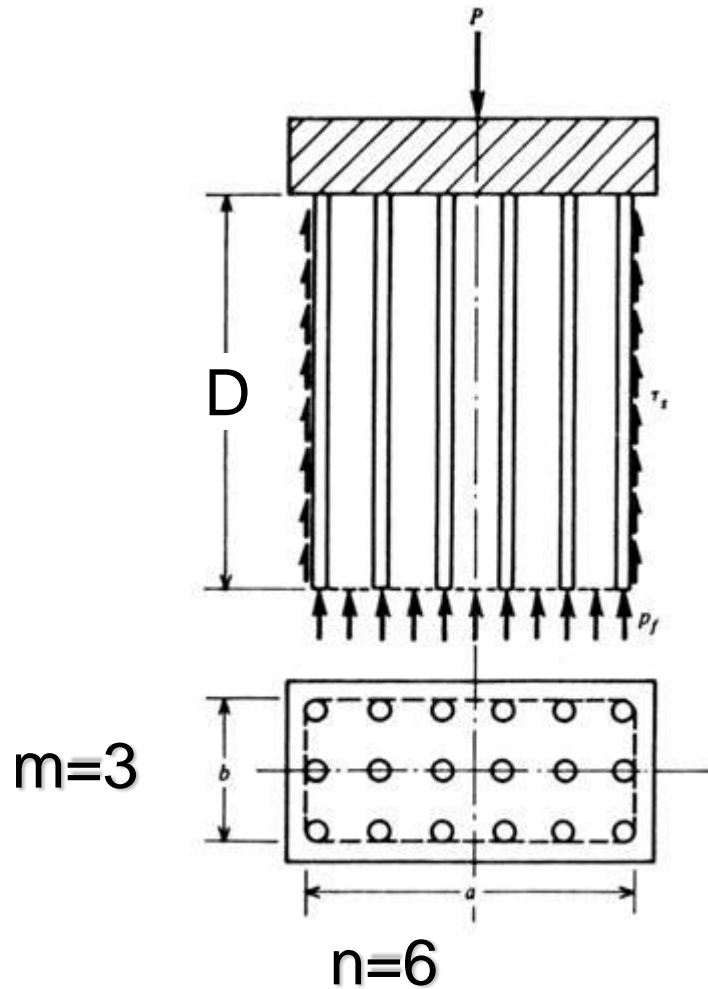

Block Failure-Clay

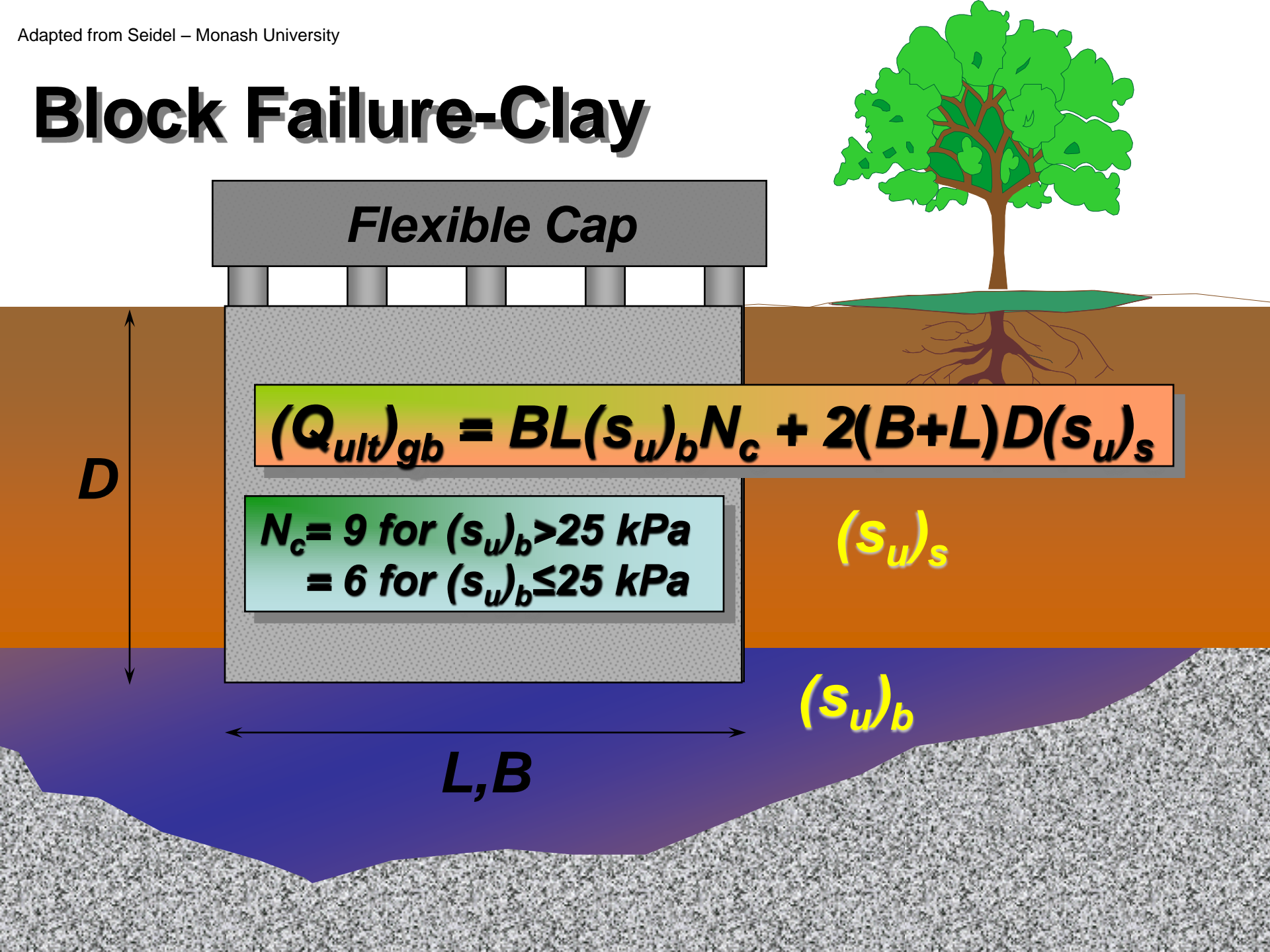

Empirical Modification-Clay

$$(Q_{ult})_{gb} = BL(s_u)_b N_c + 2(B+L)D(s_u)_s$$

gb denotes group-block failure

$$(Q_{ult})_g = \text{lower of } n(Q_{ult})_{pile} \text{ and } (Q_{ult})_{gb}$$

n

Settlement of piles and pile groups

Settlement of single piles

- Most deep foundations up to 600 mm diameter, designed using methods presented so far, will have settlements of no more than about 15 mm.
- **Therefore, typically, no settlement calculations are carried out.**
- Cases do occur when estimates of pile settlement are required.

Cases requiring estimates of pile settlement

- Large diameter end-bearing piles
- Sensitive structures
- Highly compressible strata below toe
- If downdrag loads may occur during life of structure
- Cases where structural engineer wants estimate of equivalent spring at pile location

Plant Layout Plan and Aerial View (Looking south)

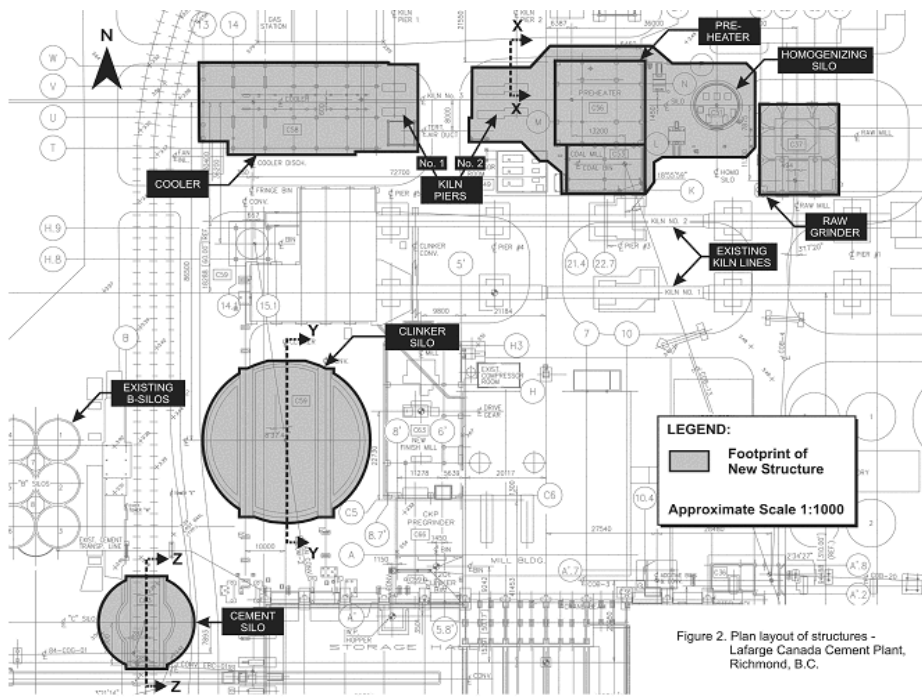
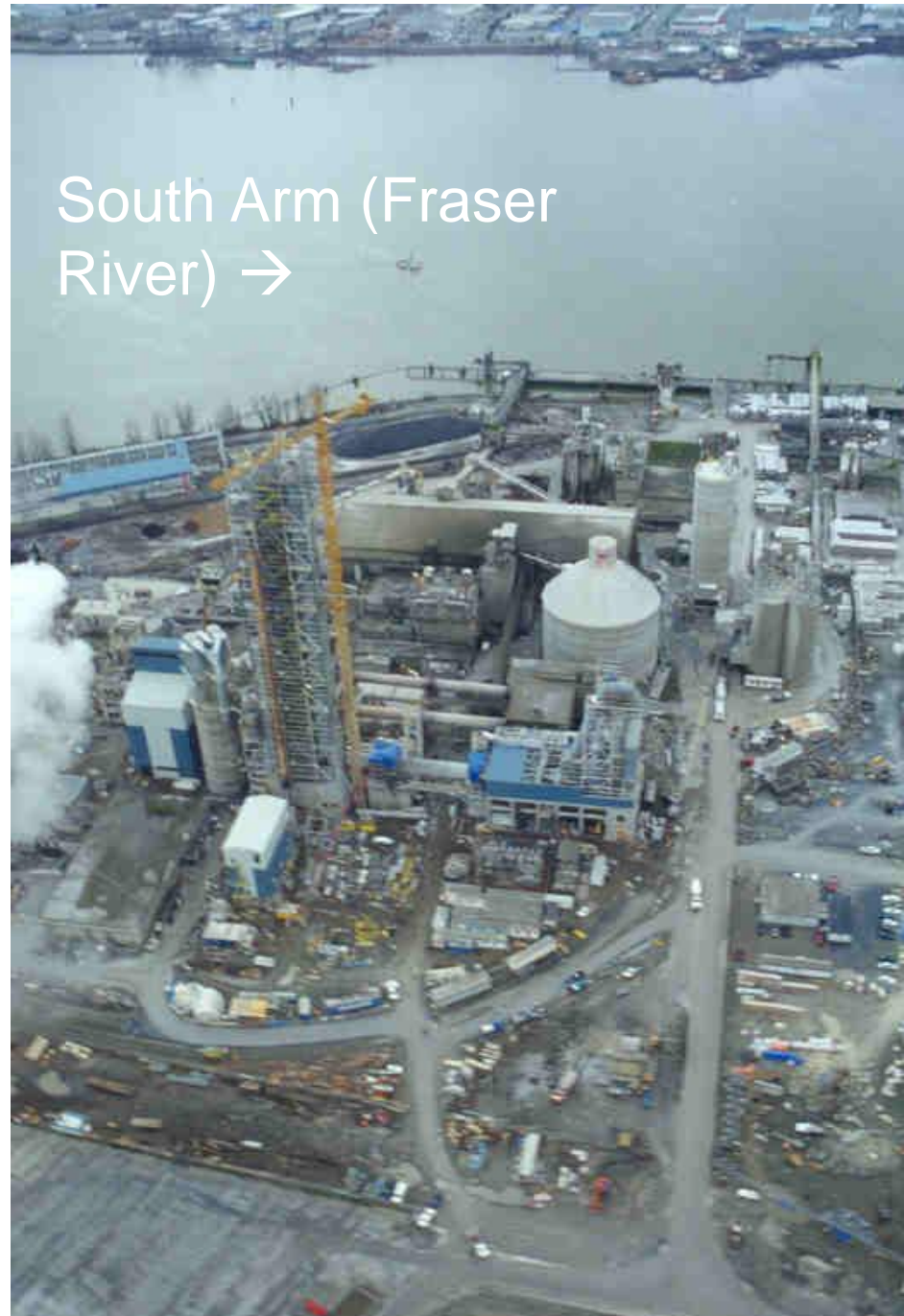
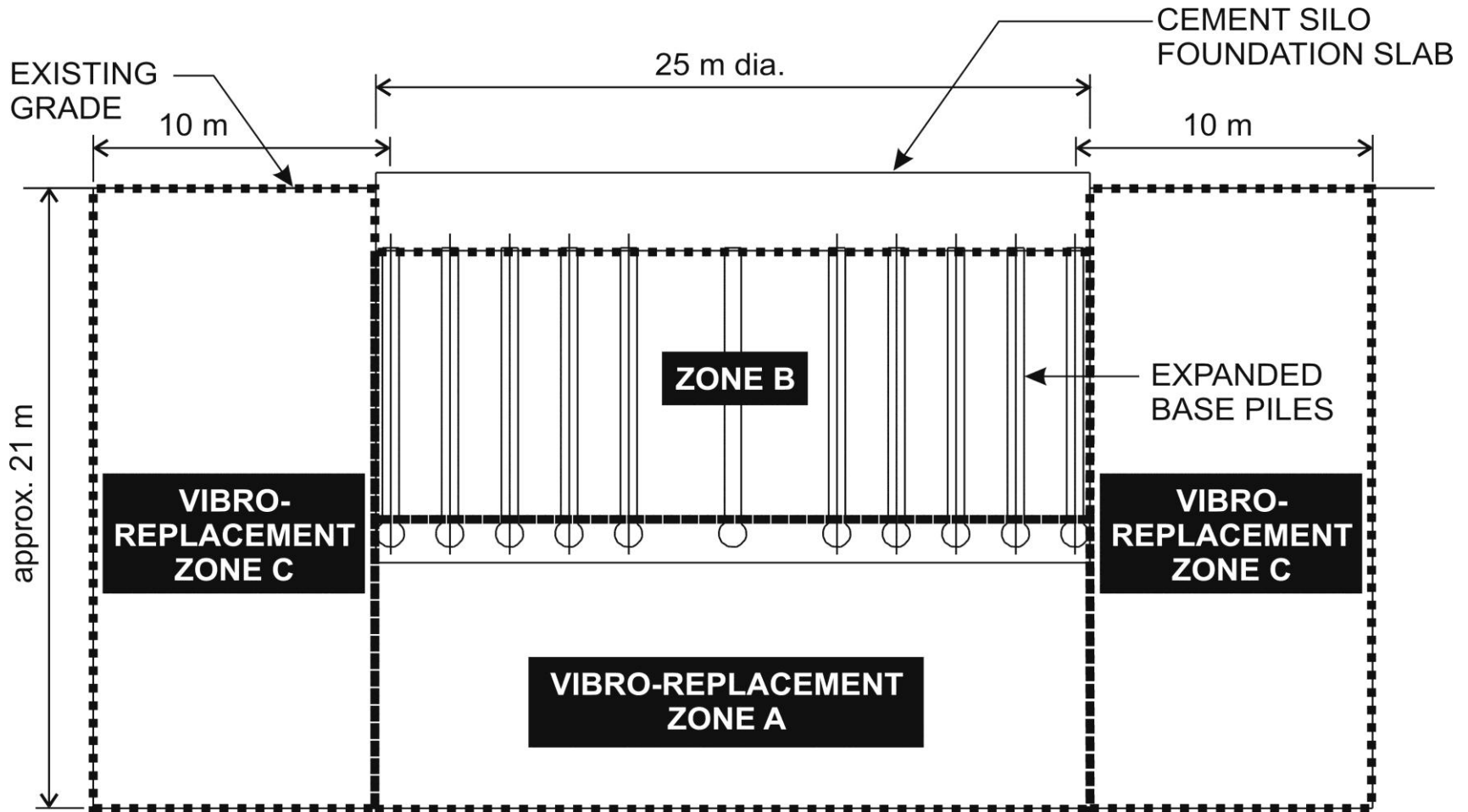

Figure 2. Plan layout of structures - Lafarge Canada Cement Plant, Richmond, B.C.



Cement Silo Foundation System



SECTION Z-Z (see Figure 2 for section location)

Typical Load – Movement Characteristics of an Axially Loaded Pile

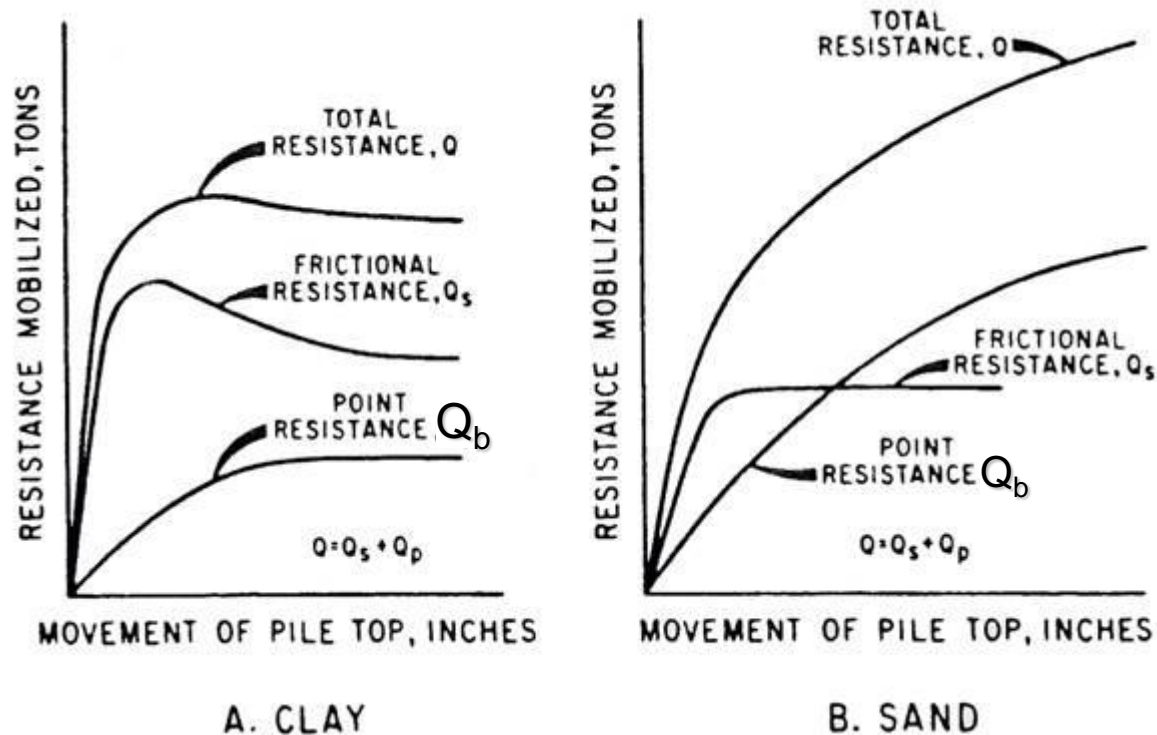

Relative Movements Required to Fully Mobilize

- Shaft Resistance = 0.5 to 2 % x Diameter
- Toe Resistance = 3 to 10 % x Diameter

Implications of load transfer

- At working load,
 - most of the load is being supported in side friction – side friction may even have exceeded its peak value
 - No or very little base resistance has been mobilized

Conclusion on load transfer

- Maximum theoretical side friction cannot be mobilized unless pile is rigid
- Limiting pile side friction is mobilized at much smaller deformations than pile tip resistance
- Residual stresses can result in available tip resistance being overestimated

Settlement of pile groups

- Elastic methods
 - interaction factors
- Equivalent raft approach

Consolidation Settlement

$$\Delta\sigma_z = \frac{Q_a}{(B_g + z)(L_g + z)}$$

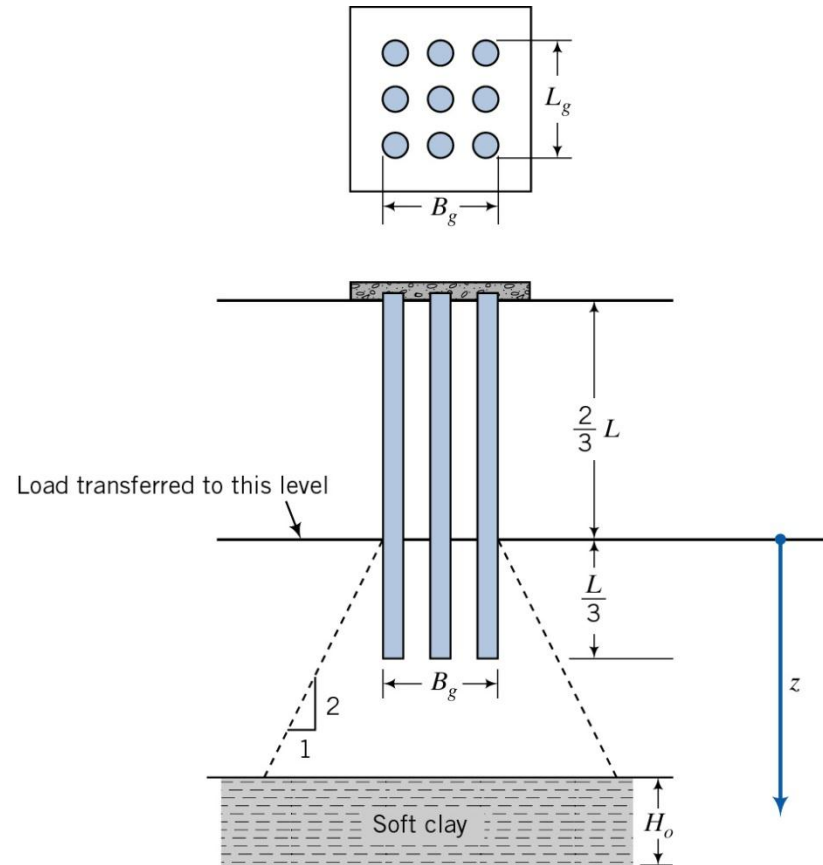

Equivalent raft approach - Tomlinson

Mobilization of resistance by skin
friction is allowed for by 4V:1H spread

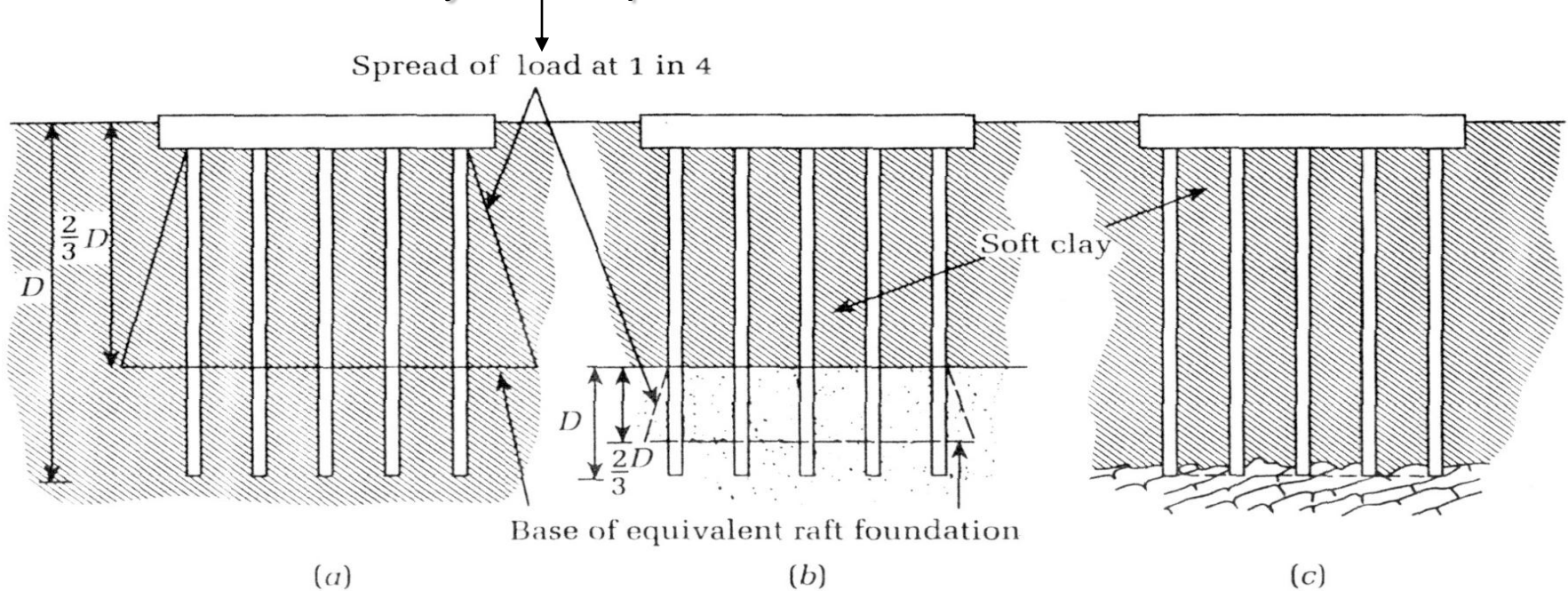

Carry out settlement analysis using methods for
shallow foundations

Downdrag

- Often called negative skin friction
- See Budhu, Section 8.10
- Effects:
 - May cause excessive settlements of foundations
 - May result in structural overstress

Negative skin friction

- Downdrag is a settlement problem, rarely a capacity problem

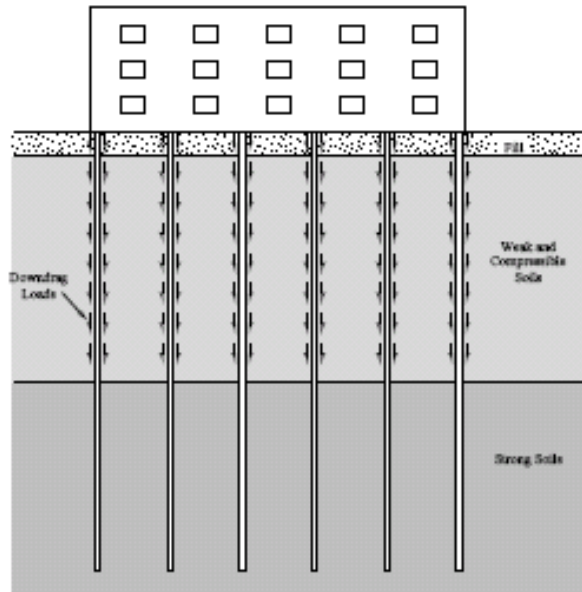

- if the pile moves, the downdrag disappears and then begins to build up again.
- Do not include live load and drag load in calculations, e.g. load cases:

- DL+negative skin friction or
- DL+LL

DESIGN FOR LATERAL LOADS ON PILES

Sources of lateral loads

- Earth pressures on pile supported retaining walls
- Seismic loads
- Pile supported dolphins and docks
- Wave forces on offshore structures
- Wind loads on structures
- Etc.

Pile arrangements to take lateral loads

- Batter or raker piles
- Vertical piles

Batter Piles

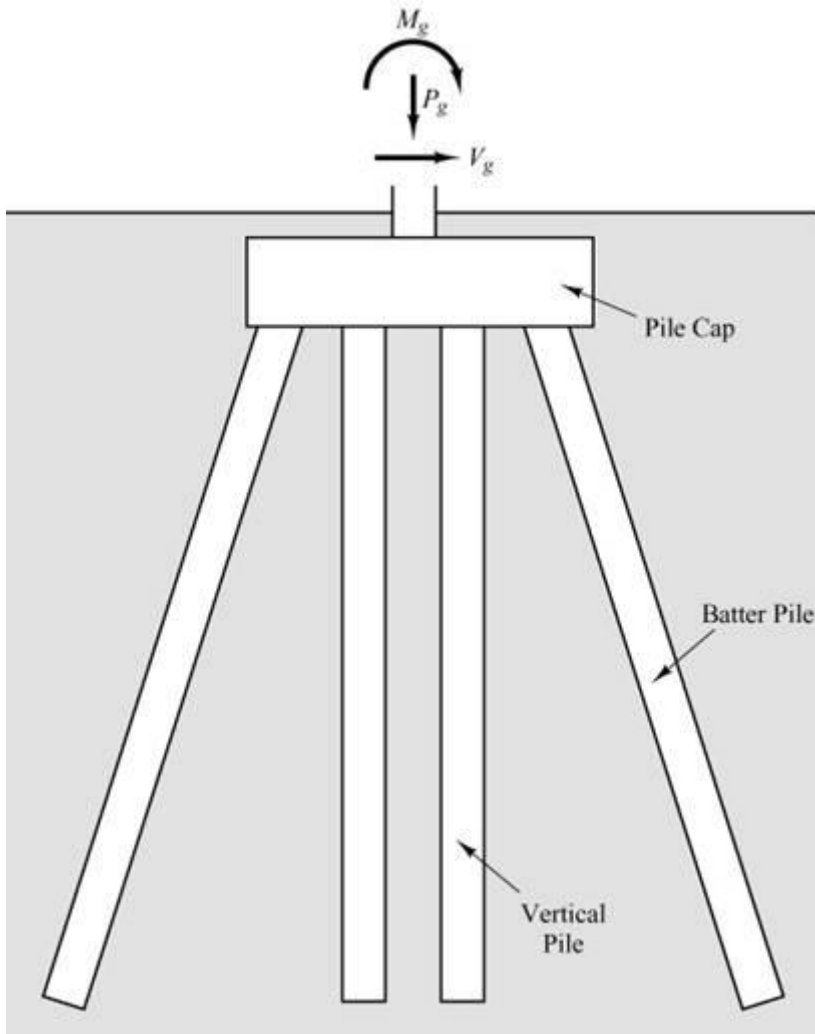

Piles driven at an angle in an attempt to have them be loaded axially when pile group is subjected to lateral load.

Problems:

- Very stiff system – not good in seismic loading
- Piles really take shear and moment loads
- Soil settlement may cause problems

Seismic Behaviour of Batter Piles

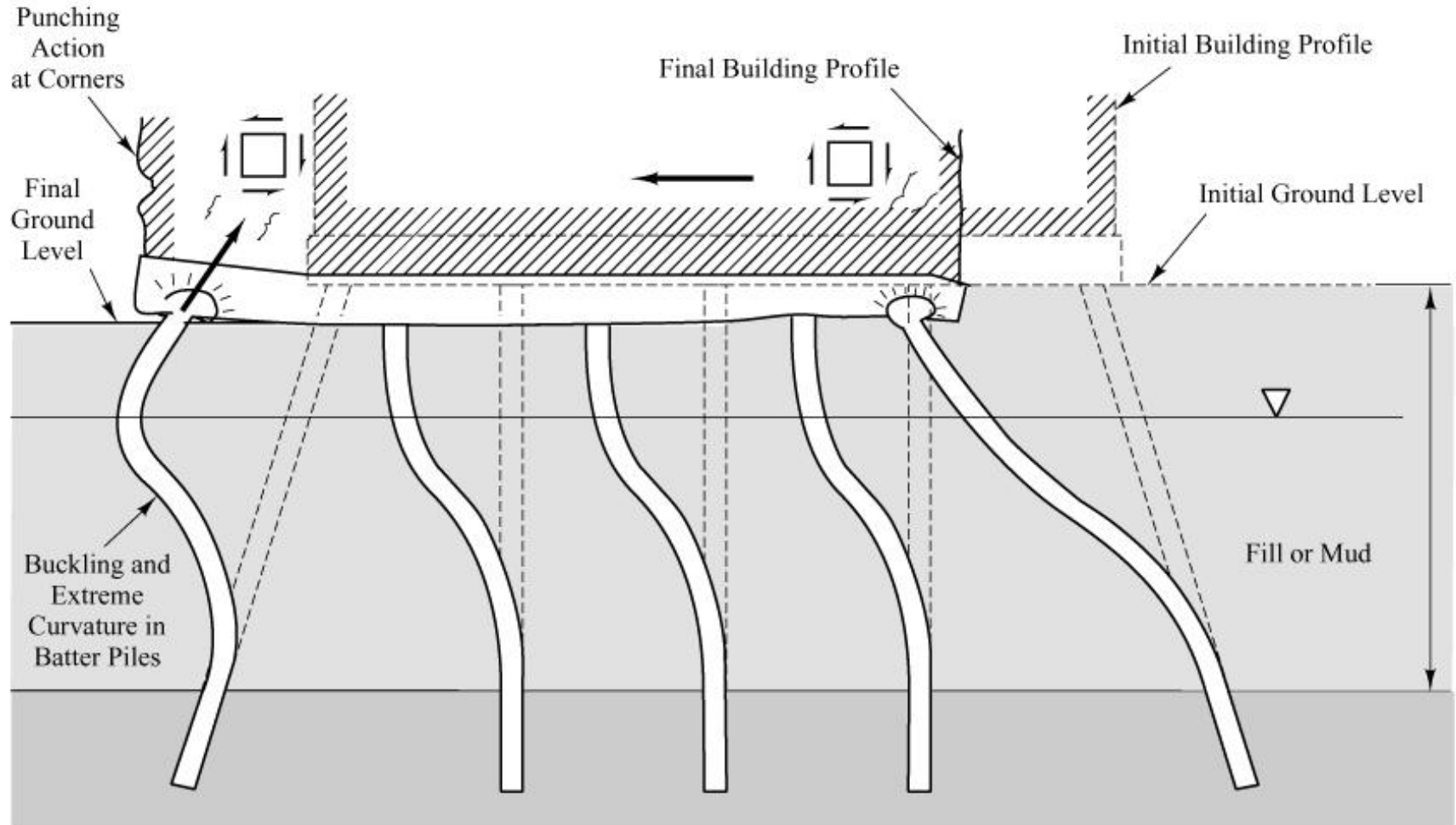

Methods of estimating lateral capacity

- Full-scale lateral load tests
- Model lateral load tests
- Lateral Static tests
- Analytical methods
 - Rigid analyses
 - Depth to fixity analysis
 - Soil-structure interaction analyses
 - P-y curves
 - Finite elements

Pile Head Constraint

Free

Fixed

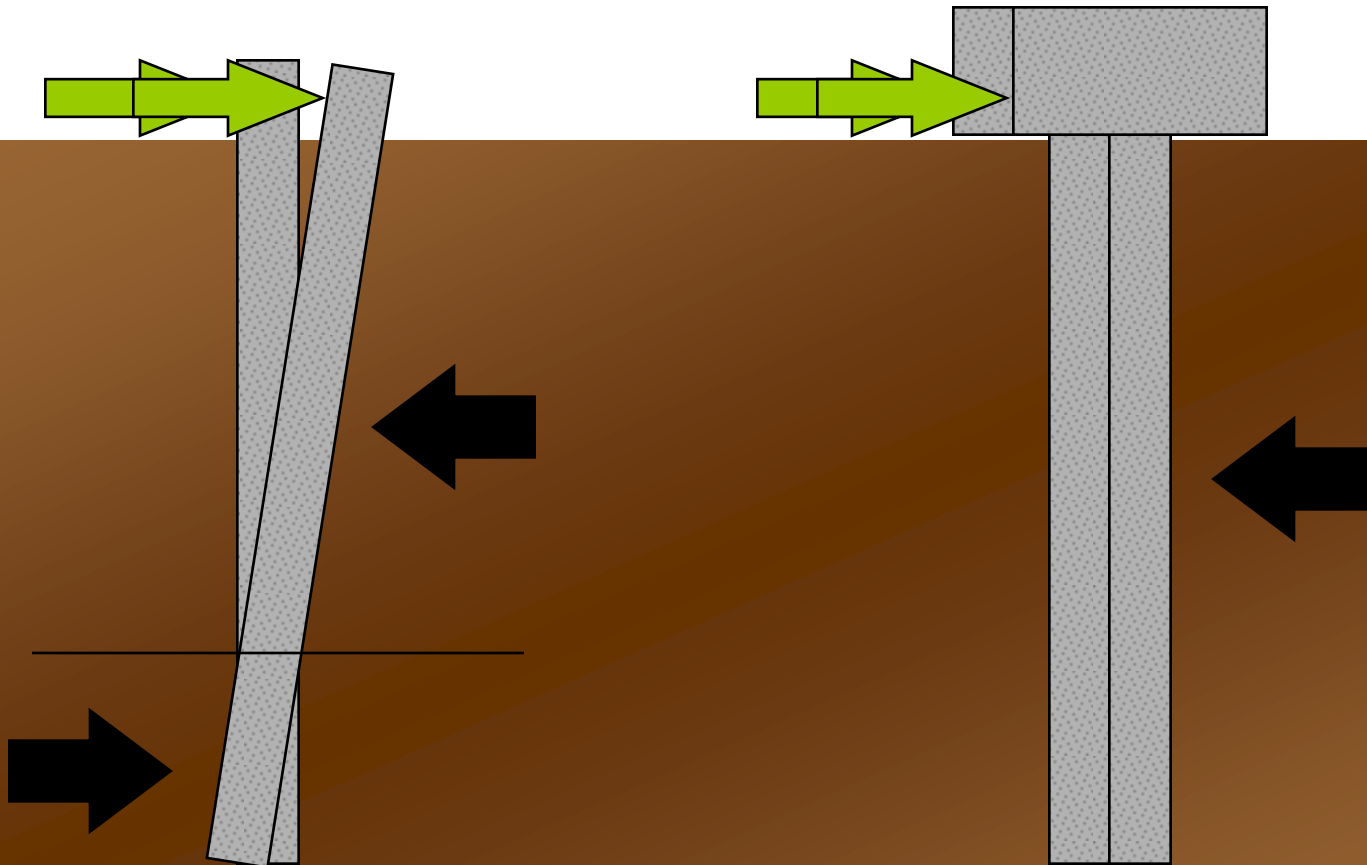

Pile Length

Short ($L/D < 10$)

Long ($L/D > 10$)

Soil fails first

Pile fails first

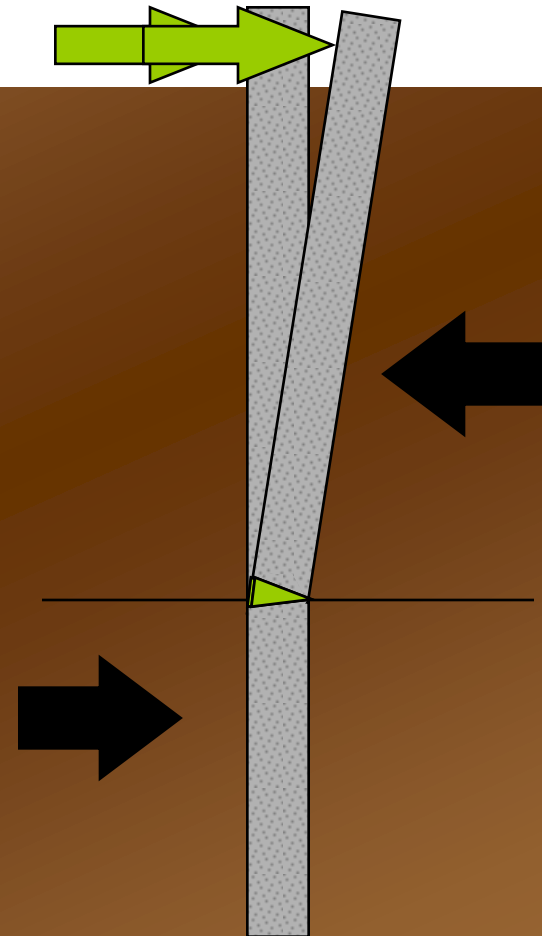
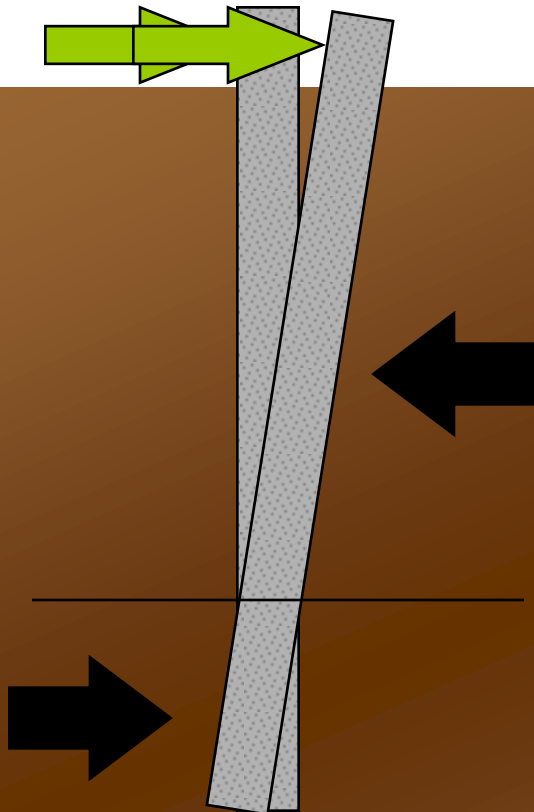

Deflections under lateral load

- Single Piles
 - Elastic beam on elastic foundation method
 - P-Y curves
 - Finite elements (continuum analysis)
- Pile Groups
 - Lead row takes more load than subsequent rows – “shadow” effect

P-y curves

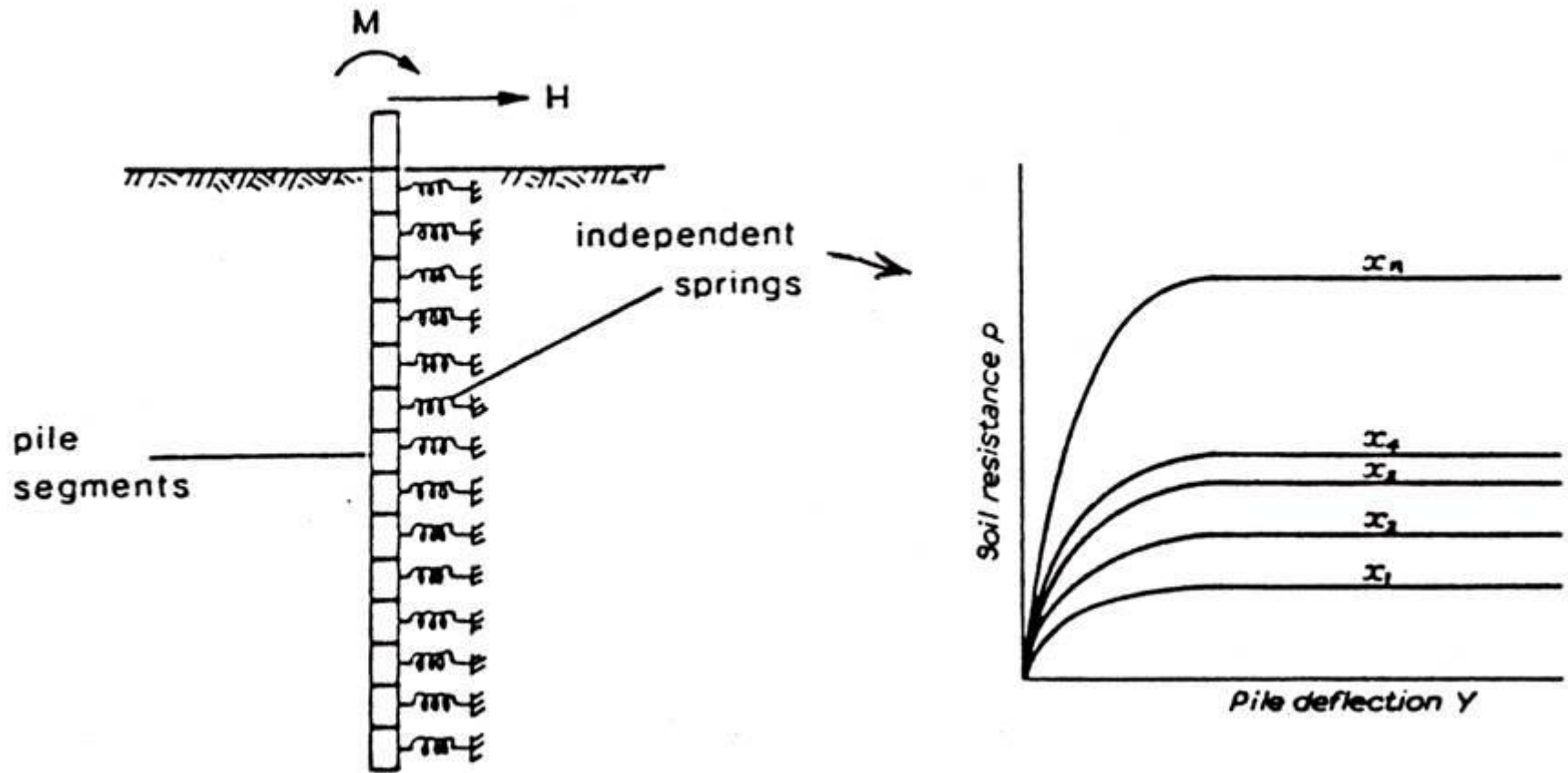

Conclusion on Piles

- Piles used to transmit loads to bearing strata at depth
- Axial loading
 - Carry load in side and base resistance
 - Pile installation alters the properties of the ground
 - design approaches must recognize installation effects and nature of load transfer
 - Settlement usually small for piles with adequate safety factor
 - Calculate settlements for large diameter piles and downdrag
- Lateral loading
 - Short pile vs long pile
 - P-y curves used to calculate load-deformation

Conclusion on Pile Groups

- Piles operate independently if at wide spacing $>6D$
- Piles interact at closer spacing
- Group capacity depends on effects of installation
 - Efficiency <1.0 in clays
 - Efficiency ≥ 1.0 in sands – use 1.0
- Check block failure
- Calculate settlements assuming equivalent raft concept