

**Chemistry 121**  
**The University of British Columbia**  
**Midterm Examination**  
**October 23, 2008**

Put the first letter  
of your family/last  
name in this box.

Time: 60 minutes

Family/Last Name (printed): \_\_\_\_\_ **ANSWER KEY** \_\_\_\_\_

First Name: \_\_\_\_\_

Signature: \_\_\_\_\_

Student Number: \_\_\_\_\_

Please check  $\checkmark$  your lecture section:

- 101 (MWF 1:00) Gates
- 102 (MWF 2:00) Krems
- 103 (MWF 3:00) MacLachlan
- 110 (MWF 10:00) Kennepohl
- 111 (MWF 11:00) Bertram
- 122 (T,Th 2:00) Burtnick
- 133 (T,Th 3:30) Melzak
- 188 (T,Th 8:00) Burtnick
- 199 (T,Th 9:30) Stewart

#### INSTRUCTIONS

1. Write all answers on this examination paper, and show full details of your solutions for Part 2.
2. Read each question carefully.
3. Check that this examination consists of **10 PAGES PRINTED ON BOTH SIDES**, as well as a periodic table which may be detached for ease of use.
4. The only calculator allowed is the Sharp EL-510R. All other calculators will be confiscated. Cell phones or other electronic communication devices are not permitted.
5. Unassembled molecular model kits may be used.

#### RULES GOVERNING FORMAL EXAMINATIONS

1. Each candidate must be prepared to produce, upon request, a UBCcard for identification.
2. Candidates are not permitted to ask questions of the invigilators, except in cases of supposed errors or ambiguities in examination questions.
3. No candidate shall be permitted to enter the examination room after the expiration of 15 minutes from the scheduled starting time, or to leave during the first 15 minutes of the examination.
4. Candidates suspected of any of the following, or similar, dishonest practices shall be immediately dismissed from the examination and shall be liable to disciplinary action:
  - having at the place of writing any books, papers or memoranda, calculators, computers, sound or image players/recorders/transmitters (including telephones), or other memory aid devices, other than those authorized by the examiners;
  - speaking or communicating with other candidates; and
  - purposely exposing written papers to the view of other candidates or imaging devices.
 The plea of accident or forgetfulness shall not be received.
5. Candidates must not destroy or mutilate any examination material; must hand in all examination papers; and must not take any examination material from the examination room without permission of the invigilator.
6. Candidates must follow any additional examination rules or directions communicated by the instructor or invigilator.

**Marks**

<b>Part</b>	<b>Question</b>	<b>Possible Marks</b>	<b>Marks</b>
<b>1</b>		<b>14</b>	
<b>2</b>	<b>1</b>	<b>5</b>	
	<b>2</b>	<b>8</b>	
	<b>3</b>	<b>4</b>	
	<b>4</b>	<b>9</b>	
	<b>5</b>	<b>4</b>	
	<b>6</b>	<b>6</b>	
	<b>7</b>	<b>4</b>	
	<b>8</b>	<b>6</b>	
<b>Total</b>		<b>60</b>	

**Part 1. Multiple Choice (14 marks total)**

For each numbered statement below, circle the letter that corresponds to the best answer. There is only one correct answer per question. Each question answered correctly is worth 2 marks.

1. What is the formula for calcium carbonate?

- (a)  $\text{Ca}(\text{CO}_3)_2$
- (b)  $\text{K}_2\text{CO}_3$
- (c)  $\text{CaCO}_3$
- (d)  $\text{KC}_2$
- (e)  $\text{CaC}_2$

2. Which of the following terms best describes carbon monoxide (CO)?

- (a) a salt
- (b) an ion
- (c) an element
- (d) an atom
- (e) a compound

3. Which of the following is not true about boron?

- (a) Boron often acquires a +3 oxidation state in compounds.
- (b) Boron is involved in the thermite reaction.
- (c) Boron can form compounds where it has an incomplete octet.
- (d) Boron compounds are important in glass production.
- (e) Boron atoms are smaller than aluminum atoms.

4. Which of the following reacts violently with water to produce hydrogen gas?

- (a)  $\text{S}_8$
- (b)  $\text{Na}_2\text{O}_2$
- (c) Cs
- (d)  $\text{Na}_2\text{O}$
- (e)  $\text{CO}_2$

5. List in order of increasing size:  $\text{Cl}^-$ ,  $\text{Te}^{2-}$ ,  $\text{K}^+$ ,  $\text{S}^{2-}$ ,  $\text{Ca}^{2+}$

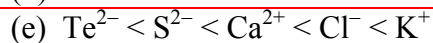
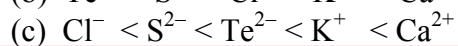
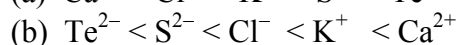
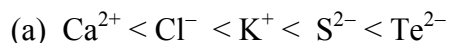

6. What is the carbon–oxygen bond order in the molecule ethanal,  $\text{CH}_3\text{CHO}$ ?

The atom connectivity for ethanal is shown below.

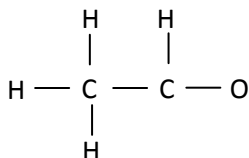

(a) 0

(b) 1

(c) 1.5

(d) 2

(e) 3

7. Based on Valence Shell Electron Pair Repulsion (VSEPR) Theory, predict the most likely perspective drawing for the hypothetical species xenon octafluoride ( $\text{XeF}_8$ ).

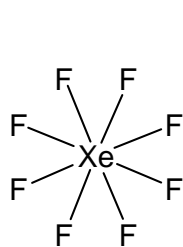

*octagonal planar*

(a)

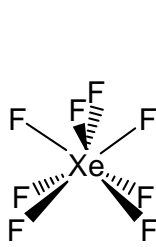

*square antiprism*

(b)

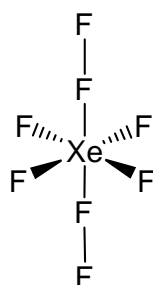

*octahedral*

(c)

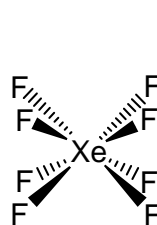

*square prism  
(or cubic)*

(d)

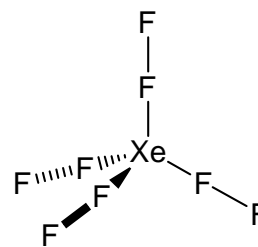

*tetrahedral*

(e)



- 4 marks** 3. The atom connectivity of  $S_8$  and  $P_4S_7$  are shown below. Complete each Lewis structure so that all atoms have a formal charge of zero. Show all lone pairs of electrons as pairs of dots and all additional bonds as lines.

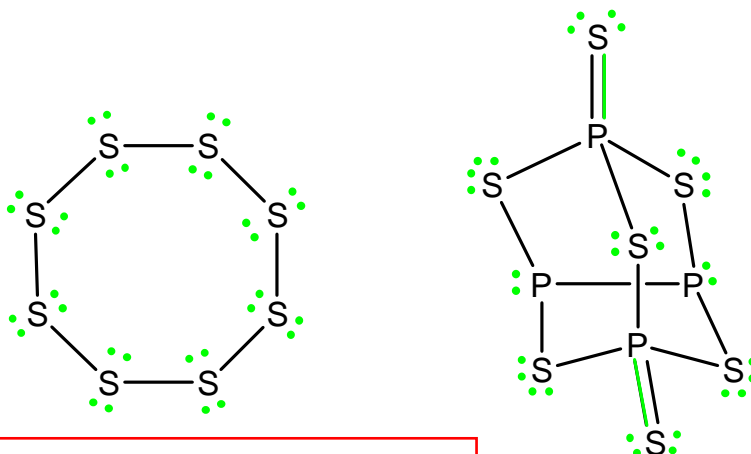

Lewis structures of  $S_8$  with expanded octets on S are not acceptable

- 9 marks** 4. Draw perspective diagrams showing the VSEPR predicted shape for the following species. In each case, indicate if the molecule is polar or nonpolar, give the name for the shape (i.e. the molecular geometry) you have drawn, and specify the requested bond angle. The central atom in each molecule is underlined.

(a) Ge $Cl_4$

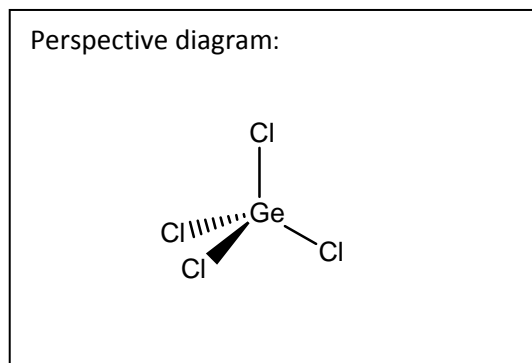

Polar or Nonpolar (circle the correct answer)

Shape: Tetrahedral

Smallest Cl–Ge–Cl bond angle: 109.5°

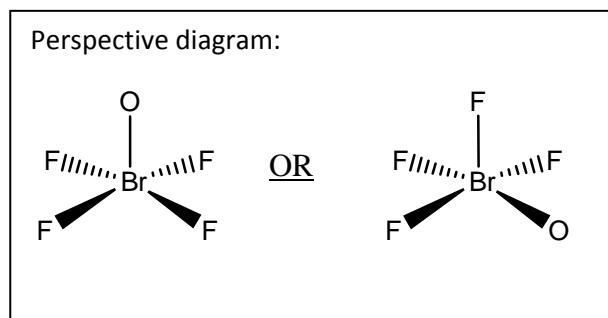
(b)  $[\text{BrOF}_4]^-$ 

Polar or Nonpolar (circle the correct answer)

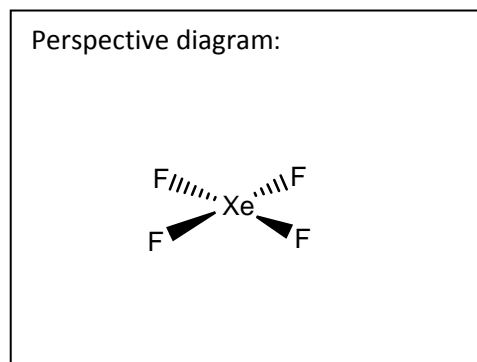
Shape: Square PyramidalSmallest F-Br-F bond angle: 90°(c)  $\text{XeF}_4$ 

Polar or Nonpolar (circle the correct answer)

Shape: Square PlanarSmallest F-Xe-F bond angle: 90°

**4 marks** 5. Predict the product(s) and balance each of the following reactions. Assume that conditions necessary to initiate a reaction are available (i.e. heating, burning, electrolysis, etc.).

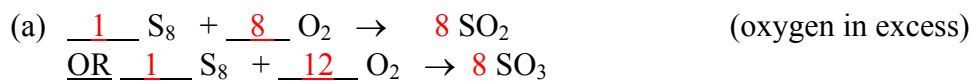

- 6 marks 6. (a) Draw the three most important resonance Lewis structures for  $[\text{PO}_2\text{F}_2]^-$  (P is the central atom). Write any non-zero formal charges on the appropriate atoms, show all lone pairs of electrons as pairs of dots, and all bond pairs as lines.

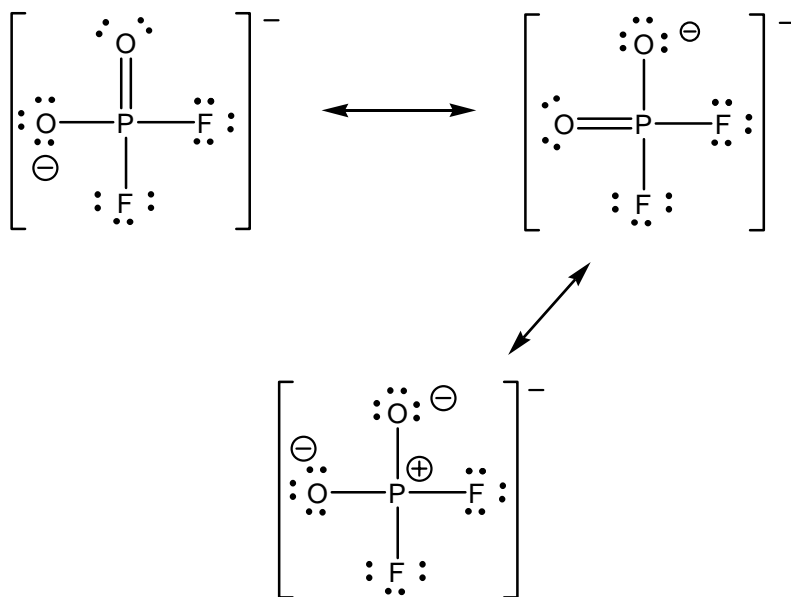

- (b)  $\text{HPO}_2\text{F}_2$  is a strong acid which dissociates in water to give  $[\text{H}_3\text{O}]^+$  and  $[\text{PO}_2\text{F}_2]^-$ .

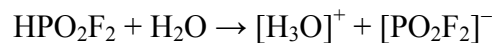

Draw the best Lewis structure for  $\text{HPO}_2\text{F}_2$ . Write any non-zero formal charges on the appropriate atoms, show all lone pairs of electrons as pairs of dots, and all bond pairs as lines.

Answer:

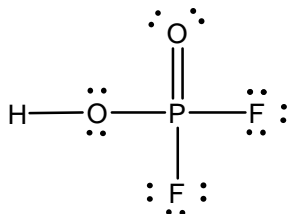

- 4 marks** 7. (a)  $\text{N}_2\text{O}_5$  is an important species in the atmosphere. Shown below is the atom connectivity of  $\text{N}_2\text{O}_5$ . Draw a Lewis structure for  $\text{N}_2\text{O}_5$  where formal charges are minimized and the octet rule is obeyed on all atoms. Write any non-zero formal charges on the appropriate atoms. Show all lone pairs of electrons as pairs of dots, and all bond pairs as lines.

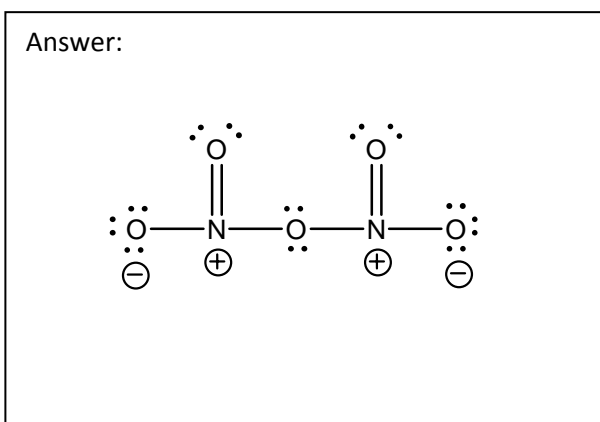
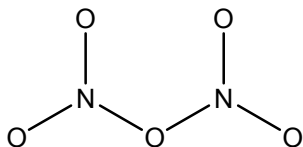

- (b) Nitrogen trioxide ( $\text{NO}_3$ ) is an important “cleaning agent” in the atmosphere.  $\text{NO}_3$  radicals react with  $\text{NO}_2$  radicals to form  $\text{N}_2\text{O}_5$  in the atmosphere. Based on this information, draw the Lewis structure for  $\text{NO}_3$ . Write any non-zero formal charges on the appropriate atoms. Show all lone pairs of electrons as pairs of dots, and all bond pairs as lines.

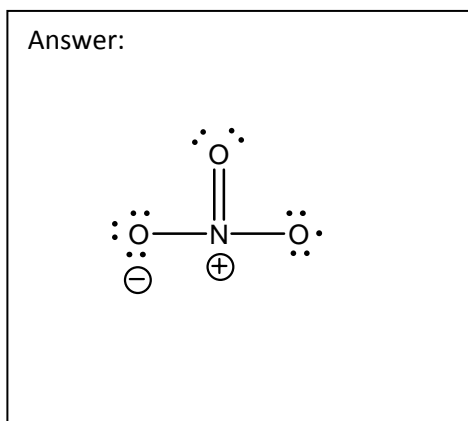

- 6 marks** 8. A chemist burned selenium (3.0 mol Se) in pure oxygen (3.0 mol O<sub>2</sub>) to afford unknown **X** (3.0 mol) as the sole product. Unknown **X** has a melting point of 340 °C. Compound **X** (1.0 mol) was treated with sodium hydroxide (2.0 mol) in 1000 mL of water. After removal of water, only a pure white solid compound **Y** (1.0 mol) remained. The volume of water removed was almost exactly 1018 mL. Subsequently, the chemist dissolved unknown **Y** (1.0 mol) in water and added hydrogen peroxide (1.0 mol). After completion of the reaction a new unknown compound **Z** (1.0 mol) was isolated. Chemical analysis indicated that the only other product of this reaction was water. The amount of water produced from this reaction was 1.0 mole.

The density of water is 1.0 g/mL.

In the boxes below, give the formulae for unknowns **X**, **Y** and **Z**.

[Space to Show Work]

Formula for compound **X**: SeO<sub>2</sub>

Formula for compound **Y**: Na<sub>2</sub>SeO<sub>3</sub>

Formula for compound **Z**: Na<sub>2</sub>SeO<sub>4</sub>

**END OF EXAMINATION**