

**GNG 1105 A and C**  
**ENGINEERING MECHANICS**

Mid-term Exam  
October 21, 2010  
Time: 80 minutes

Page 1 of 1

Prof. A. Skaff

**Closed book examination. Only non-programmable calculators are allowed.**

**Problem 1 (15 marks)**

Rod ACD is acted upon by 200N force at B, 300N at C and 400N at D. This rod is being held in equilibrium by the fixed support at A.

- Draw the Free-Body-Diagram of rod ABCD.
- Reduce the 3 forces into a force-couple system at point C.
- Find the reactions at point A.

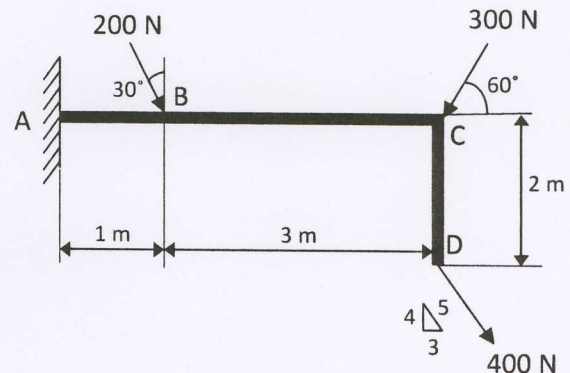

**Problem 2 (15 marks)**

Boom AC is supported by a ball and socket joint at A and by cables EC and BDC which goes over pulley D (cable BDC is a continuous cable going around the pulley).

This boom is carrying a 1000N load at its end C and it is in equilibrium.

- Draw the Free-Body-Diagram of boom AC.
- Write the tension in cables BD, CD and CE in vector form.
- Calculate the tension in cables BD, CD and CE.

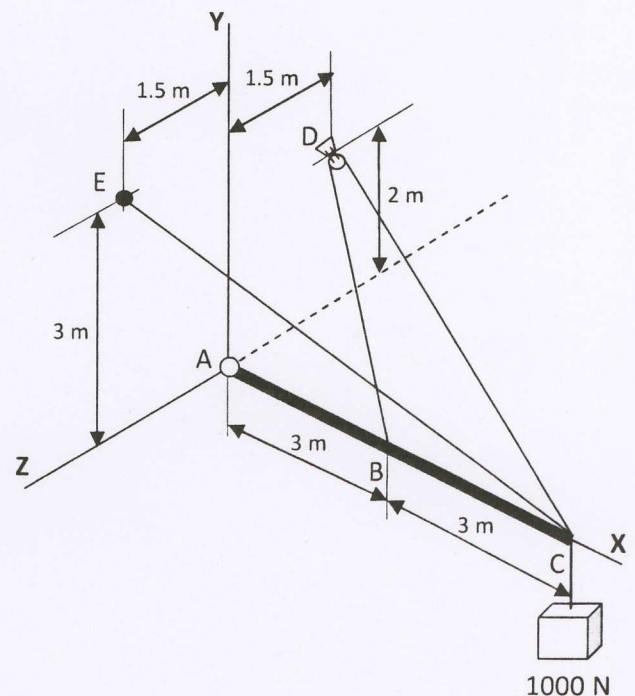

**Bonus Question (3points):** Find the components of the reaction at support A.