

COE 538 / BME 538 Midterm

Name: _____ Student #: _____ Time: 90 min.

Notes:

1. Closed book.
2. Write the answers in the space provided.
3. No question during the exam. State your assumptions.

1. Multiple Choice Questions (circle the number of the correct answer):

a) What makes a microcontroller different from a microprocessor? [1 mark]

- i) Embedded data registers and stack pointer
- ii) Embedded ALU control unit and Program Counter (PC)
- iii) Embedded peripheral devices (I/O ports, ADC, etc.)**
- iv) Embedded address and data bus to access memory

b) Assume that the size of a memory addressable by a CPU is 64KBytes, and each memory location is 1 Byte. How many lines the address bus will contain:

- i) 8 lines ii) 10 lines iii) 12 lines iv) 14 lines **v) 16 lines** [1 mark]

Show calculations that support your decision: $64\text{Kbytes} / 1 \text{ Byte} = 64\text{K} = 64 \times 2^{10} = 2^6 \times 2^{10} = 2^{16}$

Number of address lines = $\log_2 2^{16} = 16$ [1 mark]

c) Convert 2K to decimal representation: $2\text{K} = 2 \times 2^{10} = 2048$

- i) 10 bits ii) 11 bits iii) 1024 **iv) 2048** v) 0x400 vi) 0x0400 [1 mark]

2. Fill in the underlined spaces in the following programs and identify the contents of the registers after the execution of the programs:

a) Load Register A with \$CA and add it with the hex value \$36 located at \$1100. Then store the result in the memory location at \$1120. Fill in the underlined spaces in the program below: [3 marks]

```

org      $1500

ldaa    #$CA      ; load Register A with $CA

adda    $1100     ; add Reg.A with the hex value $36 located at $1100

staa    $1120     ; store the result in the memory location at $1120

swi     ; stop

```

Show the 8-bit content of Reg.A and Condition Code Reg. after the execution of the program: [3 marks]

Reg.A	<u>Bit #</u>	7	6	5	4	3	2	1	0	CCR	<u>Bit code</u>	S	X	H	I	N	Z	V	C
	<u>Bit #</u>	7	6	5	4	3	2	1	0		<u>Bit #</u>	7	6	5	4	3	2	1	0
		0	0	0	0	0	0	0	0			1	1	1	1	0	1	0	1

b) Complete the assembly instructions below by filling in the underlined spaces: [3 marks]

```

init   ldab   #$0F           ; load register B with $0F (1 E-clk)
out_lp ldx    #0008          ; load register X with 8 (2 E-clk)
in_lp  nop                   ; no operation (1 E-clk)
       dbne   x,in_lp       ; decrement reg.X and branch if not equal (3 E-clk)
       dbne   b,out_lp      ; decrement reg.B and branch if not equal (3 E-clk)
last   nop                    ; no operation (1 E-clk)
    
```

What is the program execution time from init to last, if E-clk = 40 ns. Show the calculations: [3 marks]

$$1E + [2E + (1E+3E) \times 8 + 3E] \times 15 + 1E = 557E = 557 \times 40 = 22280 \text{ ns} \approx 0.022 \text{ ms}$$

3. What are the exact addresses and contents of the topmost 7 bytes of the stack after the execution of the following assembly code (fill in the table below)? [6 marks]

	Assembly Code	Instruction Length (in bytes)	
	org \$3000		
	lds #\$4000	; 3	
	clra	; 1	
	ldab #\$57	; 2	
	ldx #\$74	; 3	
	bsr sub	; 2	
	...		
sub	pshd	; 1	
	pshx	; 1	
	leas 2, sp	; 2	

Stack Address	Stack Content
\$3FFA	\$00
\$3FFB	\$74
\$3FFC	\$00
\$3FFD	\$57
\$3FFE	\$40
\$3FFF	\$0B
\$4000	\$...

← SP

← SP

4. The system below is designed to monitor the value of the signal at PP0. When the switch SW is ON, the PP0 receives the V_{CC} (equivalent to logic 1). At that time, the HC12 must display digit "8" on the 7-segment display for 300 ms.

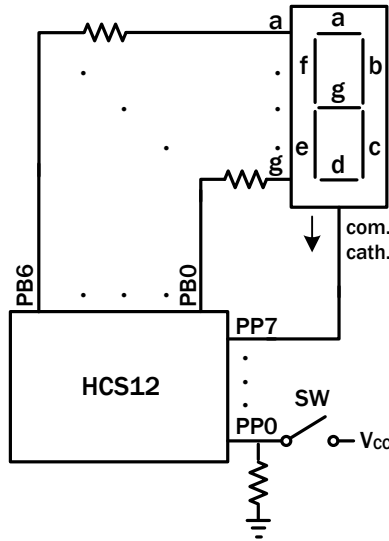

The following program is intended to perform the above task. Fill in the underlined spaces according to the comments: [10 marks]

```

org    $2000

cntr   ds.b  1

movb  #$FF, DDRB    ; Configure port B as output
bset  DDRP, $80      ; Configure pin 7 of Port P as output
bset  PTP , $80      ; Disable the 7-seg. display by setting PP7 to "1"
sw     brclr  PTP , $01 , sw ; Repeatedly read PP0 until it becomes "1"
movb  #$FF, PTB      ; Output the code of digit "8" via Port B
bclr  PTP , $80      ; Enable the 7-seg. display by clearing PP7 to "0"
movb  #3 , cntr      ; Initialize a counter
del    jsr    delayby100ms ; Time delay of 100 msec.
dec   cntr          ; Decrement the counter by 1
bne   del          ; Branch to del if cntr ≠ 0
bset  PTP , $80      ; Disable the 7-seg. display by setting PP7 to "1"
lbl    bra    lbl      ; Stop here
    
```

5. Complete the following table by filling in the *Instruction* and *Operand* columns, so that the resulting code corresponds to the *Comments* column. **[8 marks]**

Label	Instruction	Operand	Comments
	org	\$4000	Start the following code at \$4000
start	ldd	#\$8127	Make Acc D have value \$8127
	asla		Arithmetic shift left contents of AccA
	anda	#\$5A	Logic AND of AccA with value \$5A
	inca		Increment contents of Acc A
	bra	start	Go to "start"