

CHAPTER 4

Pure Bending

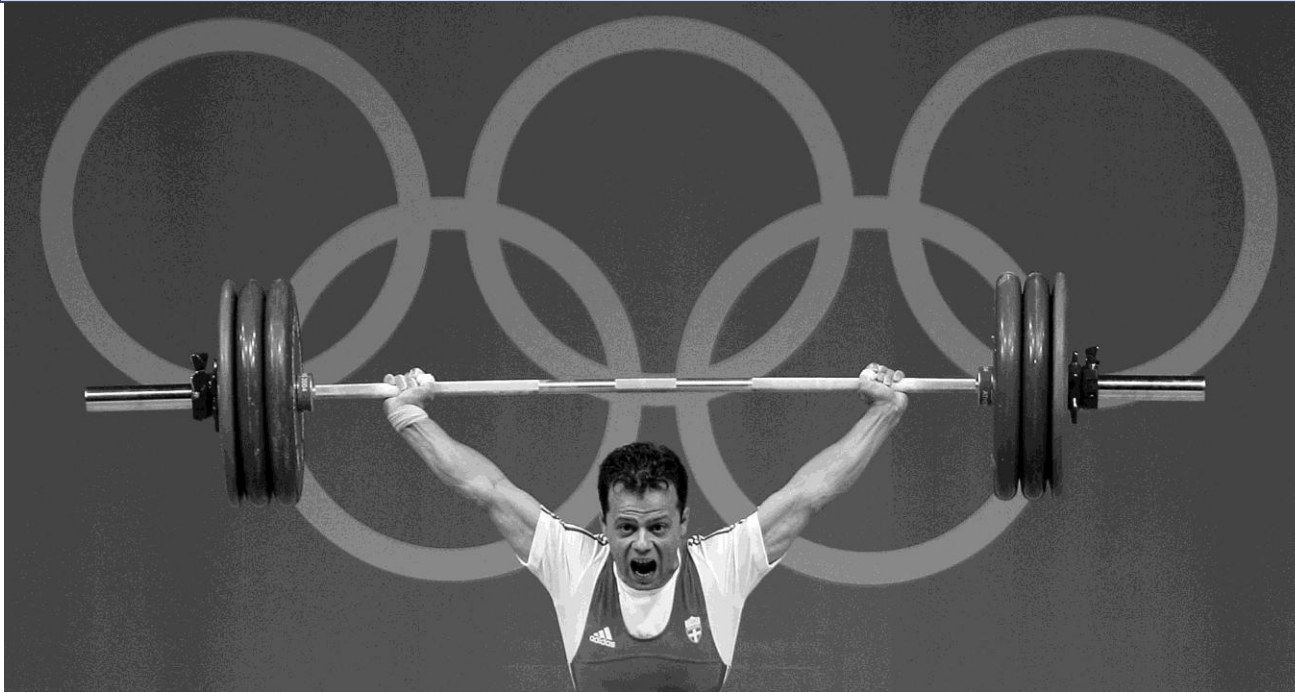

Pure Bending



Pure Bending:
Prismatic members subjected to equal and opposite couples acting in the same longitudinal plane

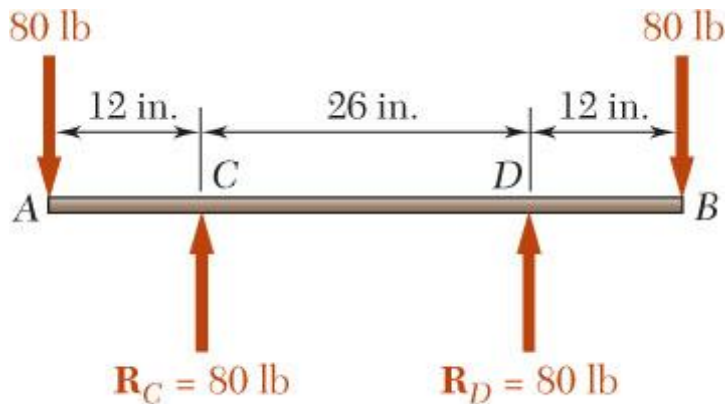

(a)



(b)

Other Loading Types

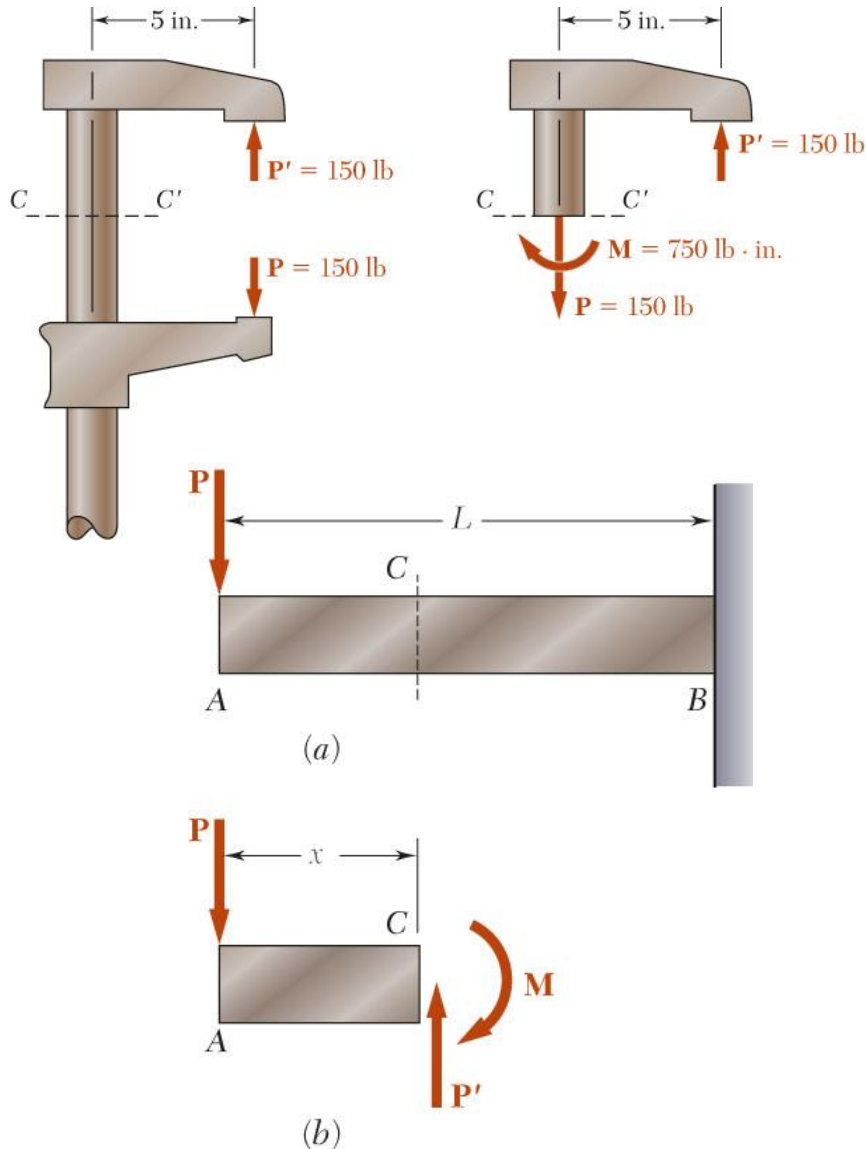

- *Eccentric Loading:* Axial loading which does not pass through section centroid produces internal forces equivalent to an axial force and a couple
- *Transverse Loading:* Concentrated or distributed transverse load produces internal forces equivalent to a shear force and a couple
- *Principle of Superposition:* The normal stress due to pure bending may be combined with the normal stress due to axial loading and shear stress due to shear loading to find the complete state of stress.

Symmetric Member in Pure Bending

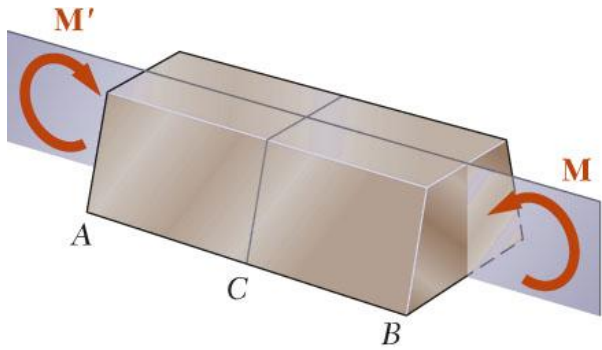

(a)

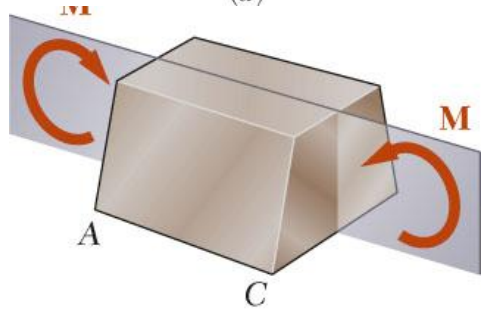

(b)

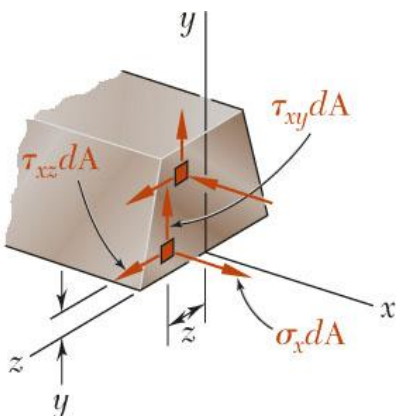

- Internal forces in any cross section are equivalent to a couple. The moment of the couple is the section *bending moment*.
- From statics, a couple M consists of two equal and opposite forces.
- The sum of the components of the forces in any direction is zero.
- The moment is the same about any axis perpendicular to the plane of the couple and zero about any axis contained in the plane.
- These requirements may be applied to the sums of the components and moments of the statically indeterminate elementary internal forces.

$$F_x = \int \sigma_x dA = 0$$

$$M_y = \int z \sigma_x dA = 0$$

$$M_z = \int -y \sigma_x dA = M$$

Bending Deformations

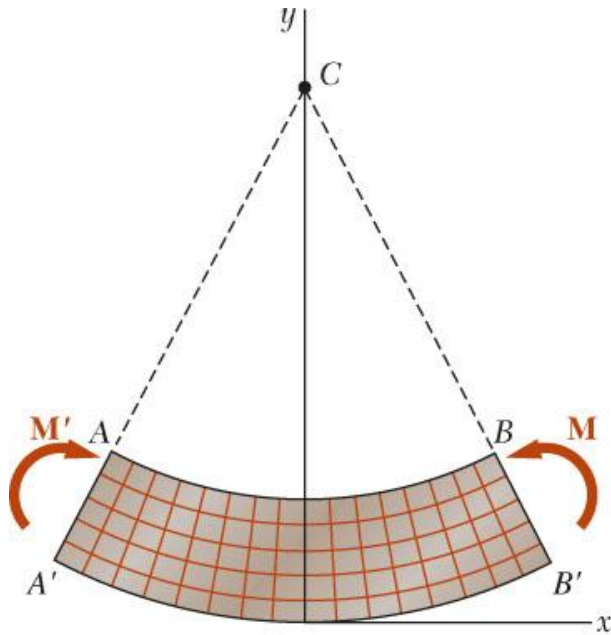

(a) Longitudinal, vertical section
(plane of symmetry)

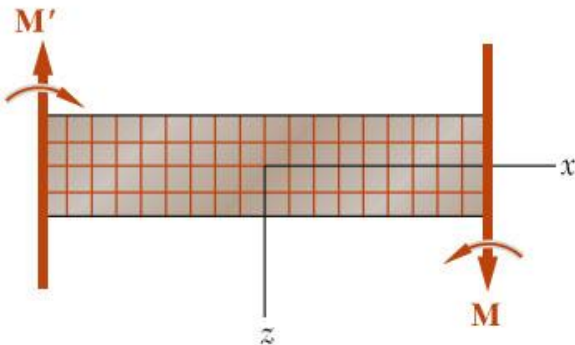

(b) Longitudinal, horizontal section

Beam with a plane of symmetry in pure bending:

- member remains symmetric
- bends uniformly to form a circular arc
- cross-sectional plane passes through arc center and remains planar
- length of top decreases and length of bottom increases
- a *neutral surface* must exist that is parallel to the upper and lower surfaces and for which the length does not change
- stresses and strains are negative (compressive) above the neutral plane and positive (tension) below it

Strain Due to Bending

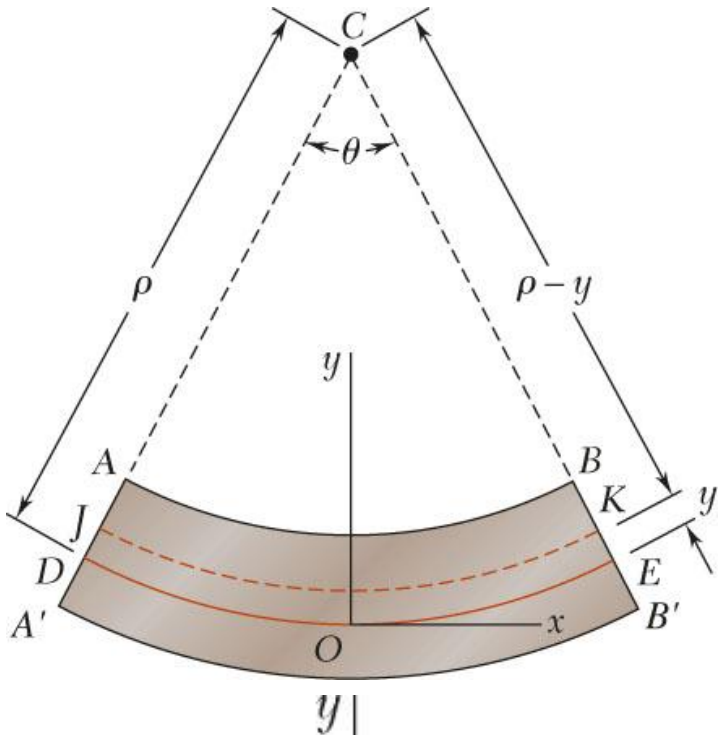

Consider a beam segment of length L .

After deformation, the length of the neutral surface remains L . At other sections,

$$L' = (\rho - y)\theta$$

$$\delta = L' - L = (\rho - y)\theta - \rho\theta = -y\theta$$

$$\epsilon_x = \frac{\delta}{L} = -\frac{y\theta}{\rho\theta} = -\frac{y}{\rho} \quad (\text{strain varies linearly})$$

$$\epsilon_m = \frac{c}{\rho} \quad \text{or} \quad \rho = \frac{c}{\epsilon_m}$$

$$\epsilon_x = -\frac{y}{c}\epsilon_m$$

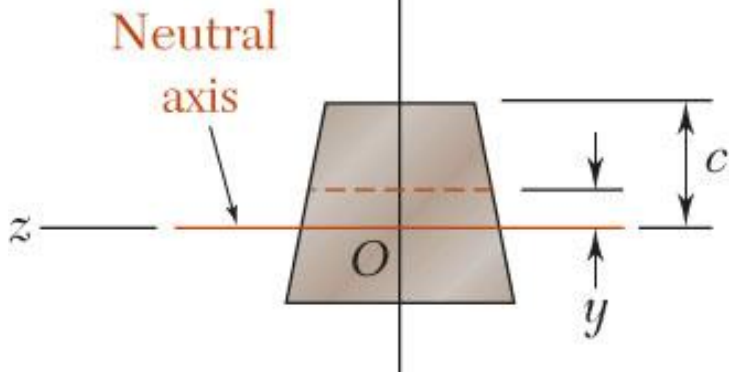

Stress Due to Bending

- For a linearly elastic material,

$$\begin{aligned}\sigma_x &= E\varepsilon_x = -\frac{y}{c} E\varepsilon_m \\ &= -\frac{y}{c} \sigma_m \quad (\text{stress varies linearly})\end{aligned}$$

- For static equilibrium,

$$F_x = 0 = \int \sigma_x dA = \int -\frac{y}{c} \sigma_m dA$$

$$0 = -\frac{\sigma_m}{c} \int y dA$$

First moment with respect to neutral plane is zero. Therefore, the neutral surface must pass through the section centroid.

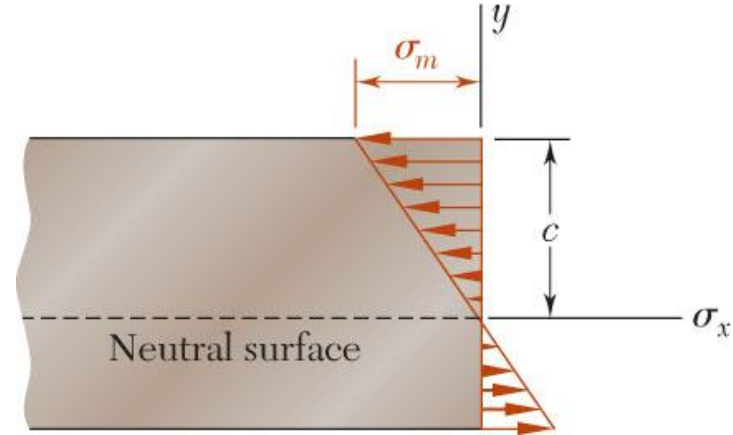

- For static equilibrium,

$$M = \int (-y \sigma_x dA) = \int (-y) \left(-\frac{y}{c} \sigma_m \right) dA$$

$$M = \frac{\sigma_m}{c} \int y^2 dA = \frac{\sigma_m I}{c}$$

$$\sigma_m = \frac{Mc}{I} = \frac{M}{S}$$

Substituting $\sigma_x = -\frac{y}{c} \sigma_m$

$$\sigma_x = -\frac{My}{I}$$

Beam Section Properties

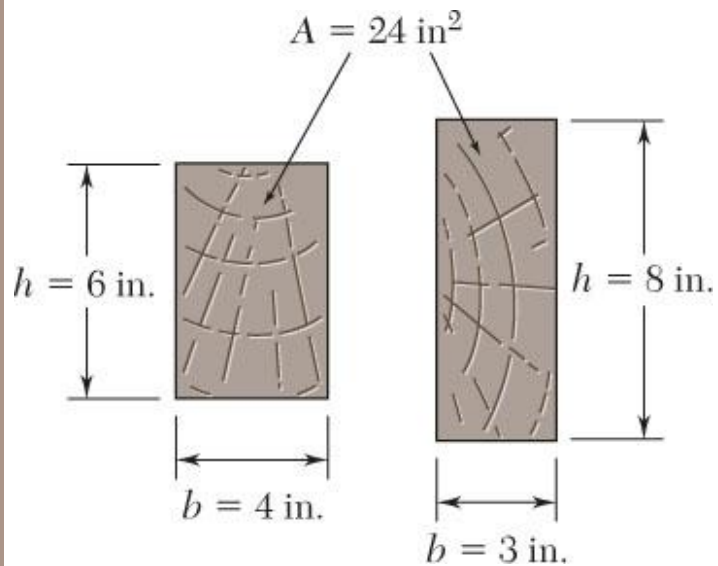

- The maximum normal stress due to bending,

$$\sigma_m = \frac{Mc}{I} = \frac{M}{S}$$

I = section moment of inertia

$$S = \frac{I}{c} = \text{section modulus}$$

A beam section with a larger section modulus will have a lower maximum stress

- Consider a rectangular beam cross section,

$$S = \frac{I}{c} = \frac{\frac{1}{12}bh^3}{h/2} = \frac{1}{6}bh^3 = \frac{1}{6}Ah$$

Between two beams with the same cross sectional area, the beam with the greater depth will be more effective in resisting bending.

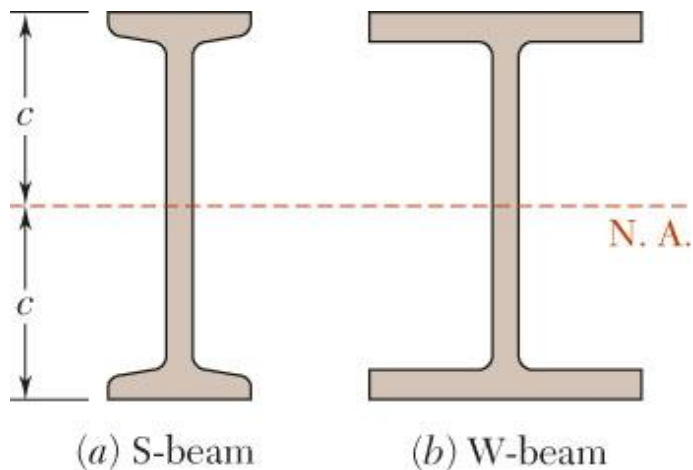

- Structural steel beams are designed to have a large section modulus.

Properties of American Standard Shapes

755

Appendix C. Properties of Rolled-Steel Shapes (SI Units)

S Shapes (American Standard Shapes)

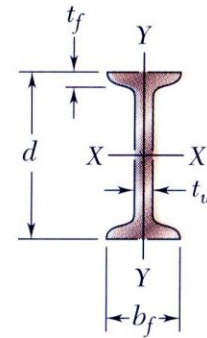

Designation†	Area A , mm ²	Depth d , mm	Flange		Web Thick- ness t_w , mm	Axis X-X			Axis Y-Y		
			Width b_f , mm	Thick- ness t_f , mm		I_x 10 ⁶ mm ⁴	S_x 10 ³ mm ³	r_x mm	I_y 10 ⁶ mm ⁴	S_y 10 ³ mm ³	r_y mm
S610 × 180	22900	622	204	27.7	20.3	1320	4240	240	34.9	341	39.0
158	20100	622	200	27.7	15.7	1230	3950	247	32.5	321	39.9
149	19000	610	184	22.1	18.9	995	3260	229	20.2	215	32.3
134	17100	610	181	22.1	15.9	938	3080	234	19.0	206	33.0
119	15200	610	178	22.1	12.7	878	2880	240	17.9	198	34.0
S510 × 143	18200	516	183	23.4	20.3	700	2710	196	21.3	228	33.9
128	16400	516	179	23.4	16.8	658	2550	200	19.7	216	34.4
112	14200	508	162	20.2	16.1	530	2090	193	12.6	152	29.5
98.3	12500	508	159	20.2	12.8	495	1950	199	11.8	145	30.4
S460 × 104	13300	457	159	17.6	18.1	385	1685	170	10.4	127	27.5
81.4	10400	457	152	17.6	11.7	333	1460	179	8.83	113	28.8
S380 × 74	9500	381	143	15.6	14.0	201	1060	145	6.65	90.8	26.1
64	8150	381	140	15.8	10.4	185	971	151	6.15	85.7	27.1

Eccentric Axial Loading in a Plane of Symmetry

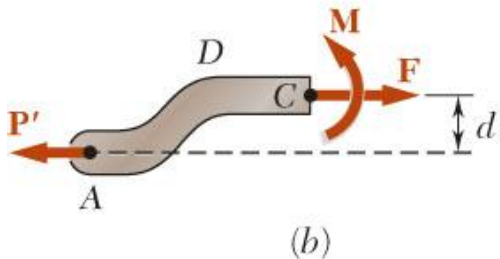
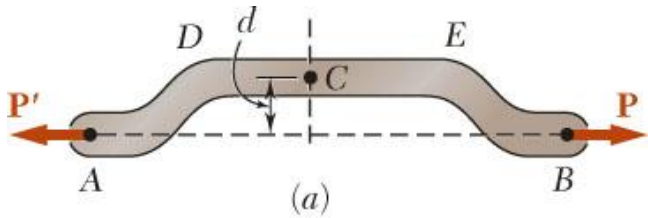

- Stress due to eccentric loading found by superposing the uniform stress due to a centric load and linear stress distribution due a pure bending moment

$$\begin{aligned}\sigma_x &= (\sigma_x)_{\text{centric}} + (\sigma_x)_{\text{bending}} \\ &= \frac{P}{A} - \frac{My}{I}\end{aligned}$$

- Eccentric loading

$$F = P$$

$$M = Pd$$

- Validity requires stresses below proportional limit, deformations have negligible effect on geometry, and stresses not evaluated near points of load application.

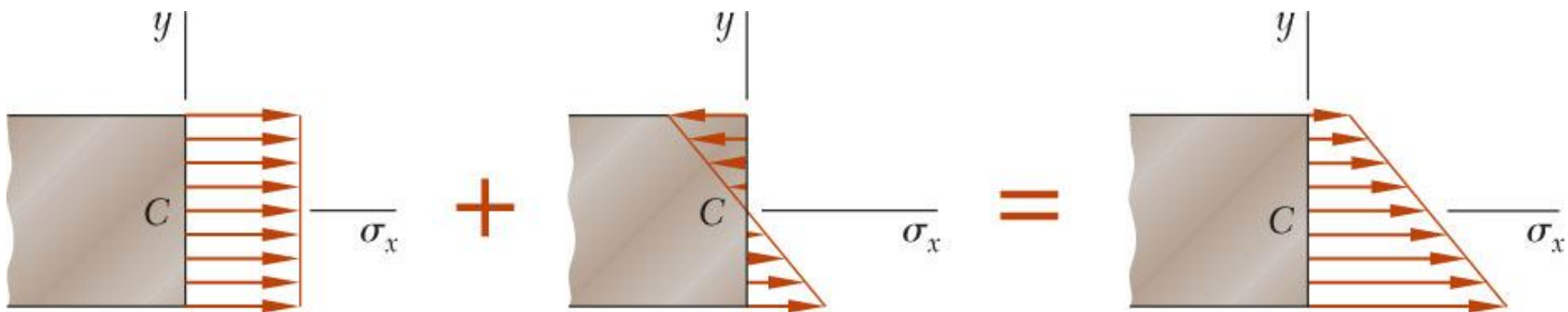

Example 4.07

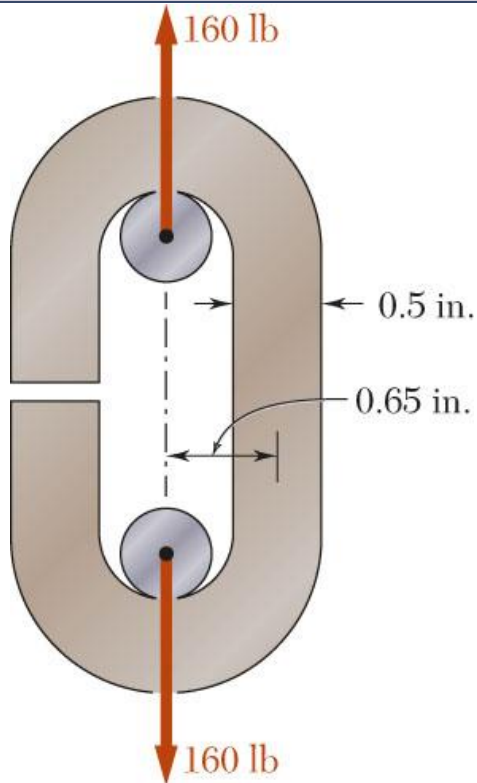

An open-link chain is obtained by bending low-carbon steel rods into the shape shown. For 160 lb load, determine (a) maximum tensile and compressive stresses, (b) distance between section centroid and neutral axis

SOLUTION:

- Find the equivalent centric load and bending moment
- Superpose the uniform stress due to the centric load and the linear stress due to the bending moment.
- Evaluate the maximum tensile and compressive stresses at the inner and outer edges, respectively, of the superposed stress distribution.
- Find the neutral axis by determining the location where the normal stress is zero.

Example 4.07

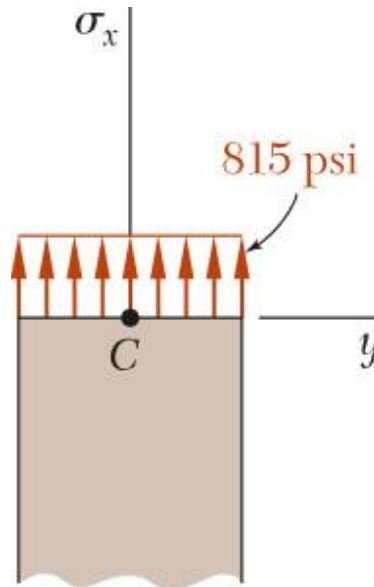
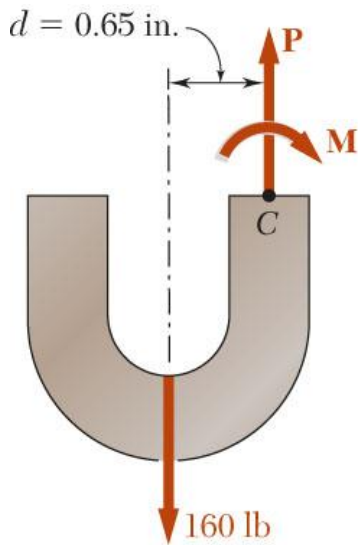

- Equivalent centric load and bending moment

$$P = 160 \text{ lb}$$

$$M = Pd = (160 \text{ lb})(0.65 \text{ in}) = 104 \text{ lb} \cdot \text{in}$$

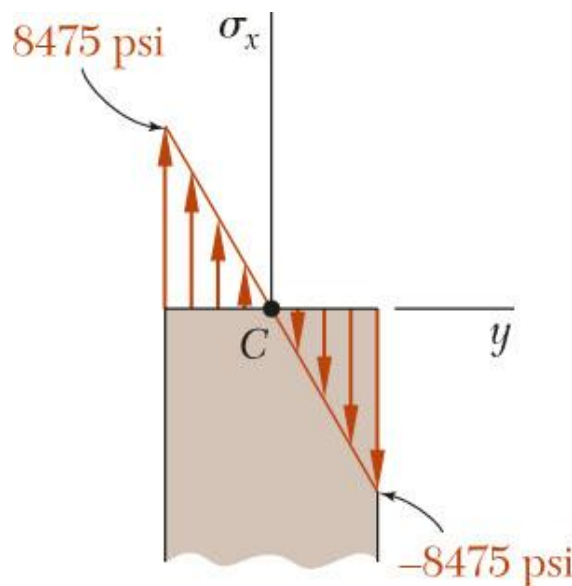

- Normal stress due to a centric load

$$A = \pi c^2 = \pi(0.25 \text{ in})^2 = 0.1963 \text{ in}^2$$

$$\sigma_0 = \frac{P}{A} = \frac{160 \text{ lb}}{0.1963 \text{ in}^2} = 815 \text{ psi}$$

- Normal stress due to bending moment

$$I = \frac{1}{4} \pi c^4 = \frac{1}{4} \pi (0.25)^4 = 3.068 \times 10^{-3} \text{ in}^4$$

$$\sigma_m = \frac{Mc}{I} = \frac{(104 \text{ lb} \cdot \text{in})(0.25 \text{ in})}{3.068 \times 10^{-3} \text{ in}^4} = 8475 \text{ psi}$$

Example 4.07

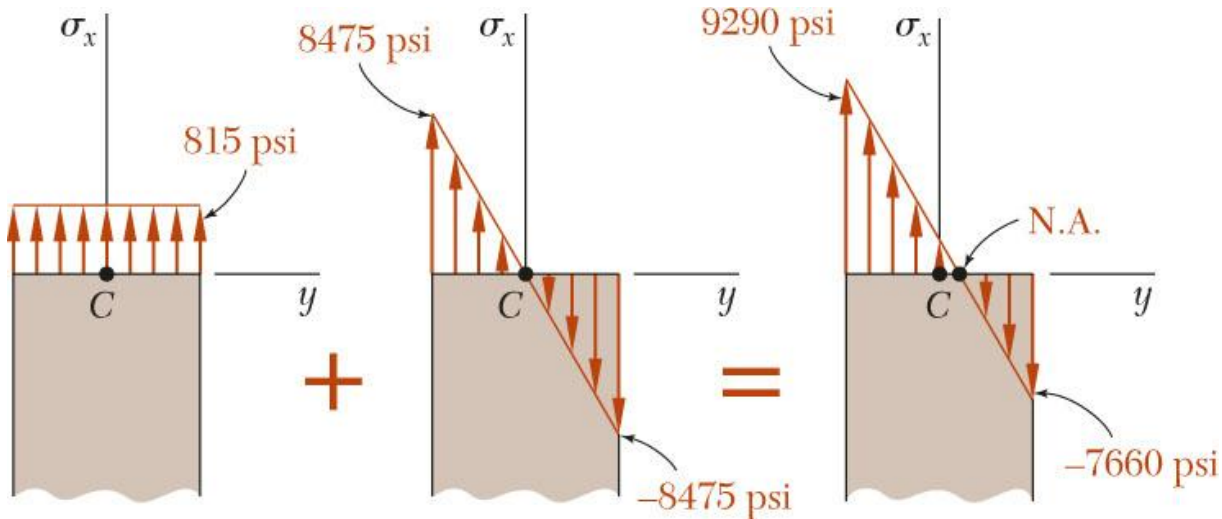

- Maximum tensile and compressive stresses

$$\begin{aligned}\sigma_t &= \sigma_0 + \sigma_m \\ &= 815 + 8475\end{aligned}$$

$$\sigma_t = 9260 \text{ psi}$$

$$\begin{aligned}\sigma_c &= \sigma_0 - \sigma_m \\ &= 815 - 8475\end{aligned}$$

$$\sigma_c = -7660 \text{ psi}$$

- Neutral axis location

$$0 = \frac{P}{A} - \frac{My_0}{I}$$

$$y_0 = \frac{P}{A} \frac{I}{M} = (815 \text{ psi}) \frac{3.068 \times 10^{-3} \text{ in}^4}{105 \text{ lb} \cdot \text{in}}$$

$$y_0 = 0.0240 \text{ in}$$

Sample Problem 4.8

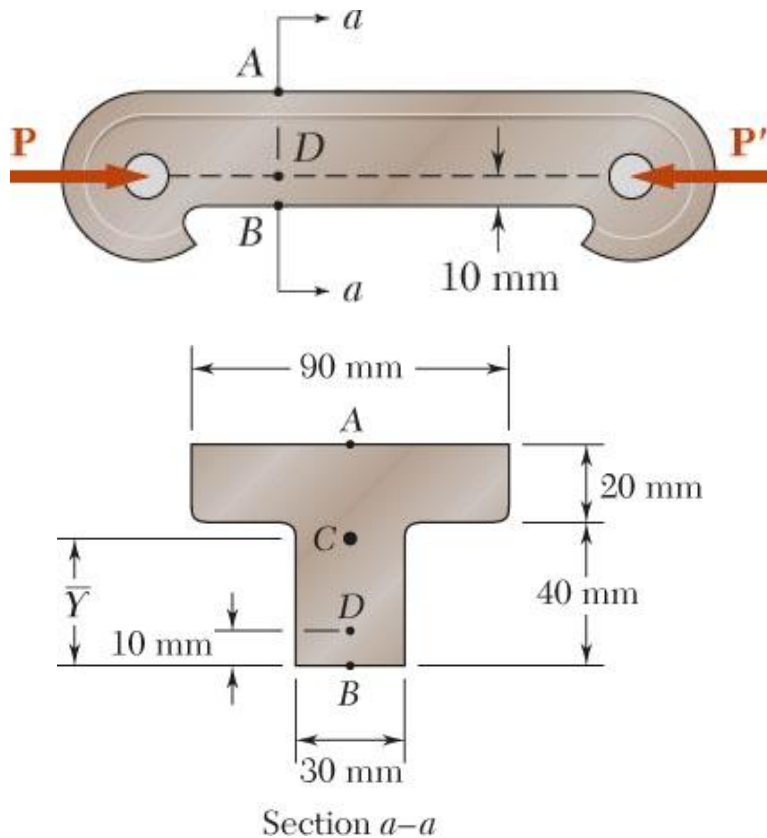

The largest allowable stresses for the cast iron link are 30 MPa in tension and 120 MPa in compression. Determine the largest force P which can be applied to the link.

SOLUTION:

- Determine equivalent centric load and bending moment.
- Superpose the stress due to a centric load and the stress due to bending.
- Evaluate the critical loads for the allowable tensile and compressive stresses.
- The largest allowable load is the smallest of the two critical loads.

From Sample Problem 4.2,

$$A = 3 \times 10^{-3} \text{ m}^2$$

$$\bar{Y} = 0.038 \text{ m}$$

$$I = 868 \times 10^{-9} \text{ m}^4$$

Sample Problem 4.8

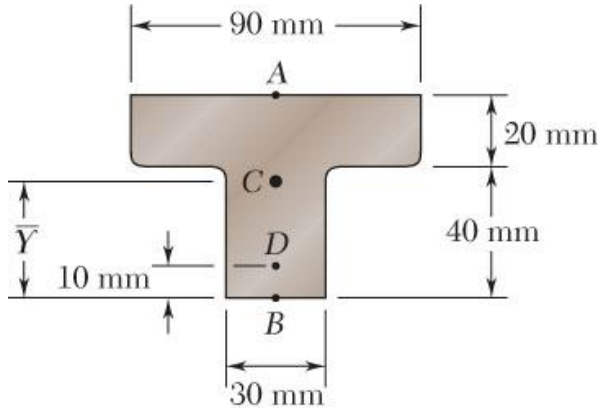

Section a-a

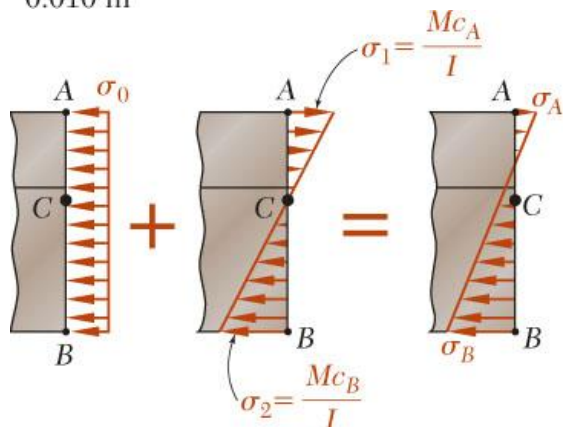
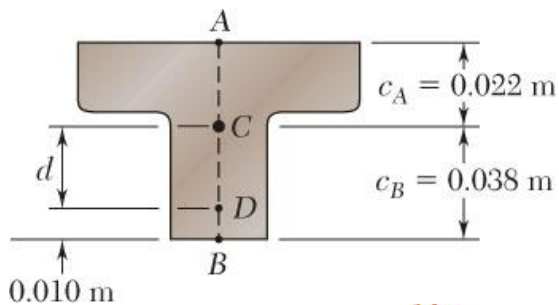

- Determine equivalent centric and bending loads.

$$d = 0.038 - 0.010 = 0.028 \text{ m}$$

$P = \text{centric load}$

$$M = Pd = 0.028P = \text{bending moment}$$

- Superpose stresses due to centric and bending loads

$$\sigma_A = -\frac{P}{A} + \frac{Mc_A}{I} = -\frac{P}{3 \times 10^{-3}} + \frac{(0.028P)(0.022)}{868 \times 10^{-9}} = +377P$$

$$\sigma_B = -\frac{P}{A} - \frac{Mc_A}{I} = -\frac{P}{3 \times 10^{-3}} - \frac{(0.028P)(0.022)}{868 \times 10^{-9}} = -1559P$$

- Evaluate critical loads for allowable stresses.

$$\sigma_A = +377P = 30 \text{ MPa} \quad P = 79.6 \text{ kN}$$

$$\sigma_B = -1559P = -120 \text{ MPa} \quad P = 77.0 \text{ kN}$$

- The largest allowable load

$$P = 77.0 \text{ kN}$$