

- **Text Book: Mechanics of Materials (Mandatory)**

F.P. Beer, E.R. Johnston, Jr. ; J. T. DeWolf and D. F. Mazurek
5th edition, McGraw-Hill, 2009.

- **Lectures: Mon & Wed 18:30-21:00 H-507**

Tutorial:

CG: Mon&Wed, 17:30-18:20, H-631

CH: Mon&Wed, 17:30-18:20, H-629

Labs and Tutorials: Start Monday July 4

Grading

- **Lab and Reports** 15 %
- **Term Test #1** 15 %
- **Term Test #2** 15 %
- **Final Examination** 55 %



INTRODUCTION: Concept of Stress

- The main objective is to provide the future engineer with the means of analyzing and designing various machines and load bearing structures.
 - i-Basic concepts and principles of mechanics of materials
 - ii-Application to engineering problems
- Both the analysis and design of a given structure involve the determination of *stresses* and *deformations*. This chapter is devoted to the concept of stress.

Review of Statics

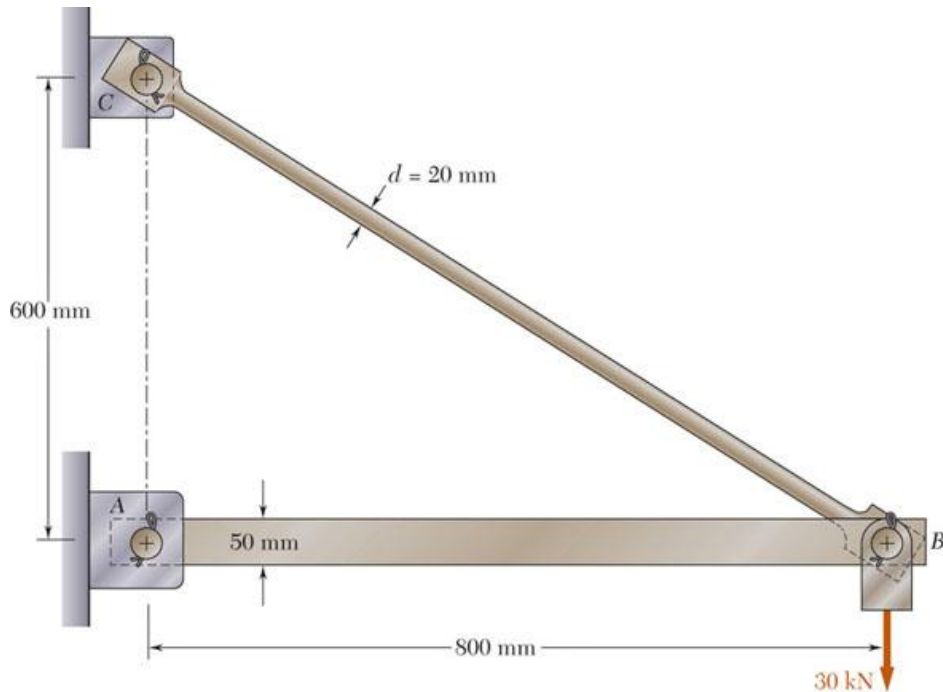

- The structure is designed to support a 30 kN load
- The structure consists of a boom and rod joined by pins (zero moment connections) at the junctions and supports
- Perform a static analysis to determine the internal force in each structural member and the reaction forces at the supports

Structure Free-Body Diagram

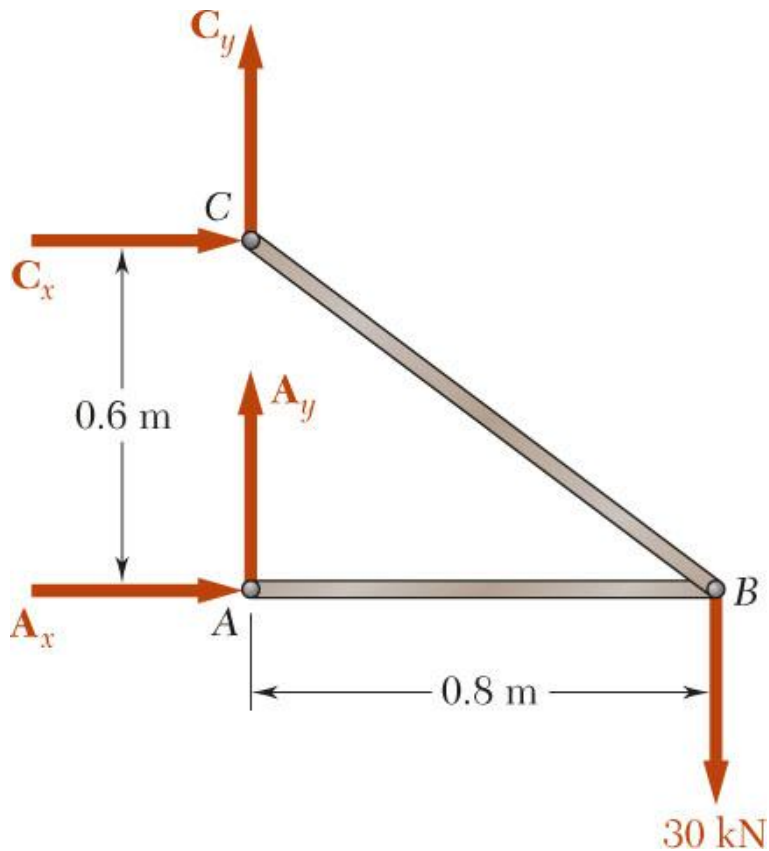

- Structure is detached from supports and the loads and reaction forces are indicated
- Conditions for static equilibrium:
 - $+ \curvearrowright \sum M_C = 0 = A_x(0.6 \text{ m}) - (30 \text{ kN})(0.8 \text{ m})$
 $A_x = 40 \text{ kN}$
 - $\rightarrow \sum F_x = 0 = A_x + C_x$
 $C_x = -A_x = -40 \text{ kN}$
 - $\uparrow \sum F_y = 0 = A_y + C_y - 30 \text{ kN} = 0$
 $A_y + C_y = 30 \text{ kN}$
- A_y and C_y can not be determined from these equations

Component Free-Body Diagram

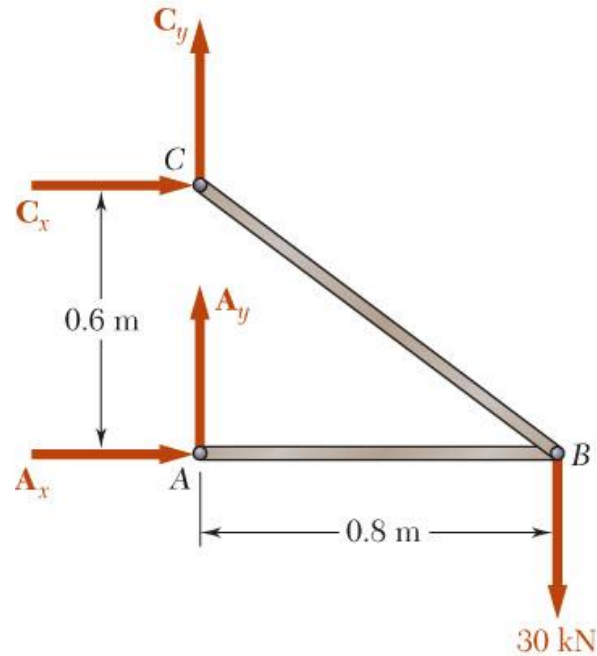

- In addition to the complete structure, each component must satisfy the conditions for static equilibrium
- Consider a free-body diagram for the boom:
$$+\circlearrowleft \sum M_B = 0 = -A_y(0.8 \text{ m})$$

$$A_y = 0$$

substitute into the structure equilibrium equation

$$C_y = 30 \text{ kN}$$

Results:

$$A = 40 \text{ kN} \rightarrow \quad C_x = 40 \text{ kN} \leftarrow \quad C_y = 30 \text{ kN} \uparrow$$

Reaction forces are directed along boom and rod

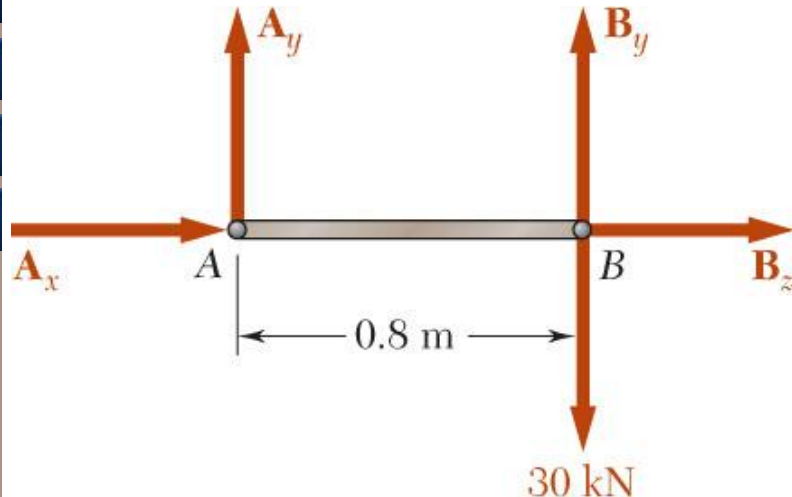

Method of Joints

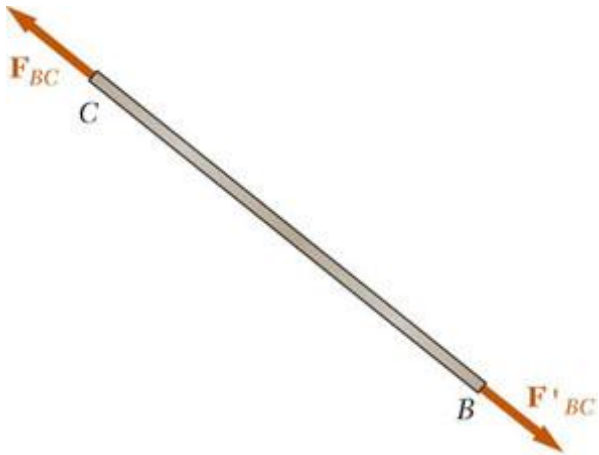

- The boom and rod are 2-force members, i.e., the members are subjected to only two forces which are applied at member ends
- For equilibrium, the forces must be parallel to to an axis between the force application points, equal in magnitude, and in opposite directions

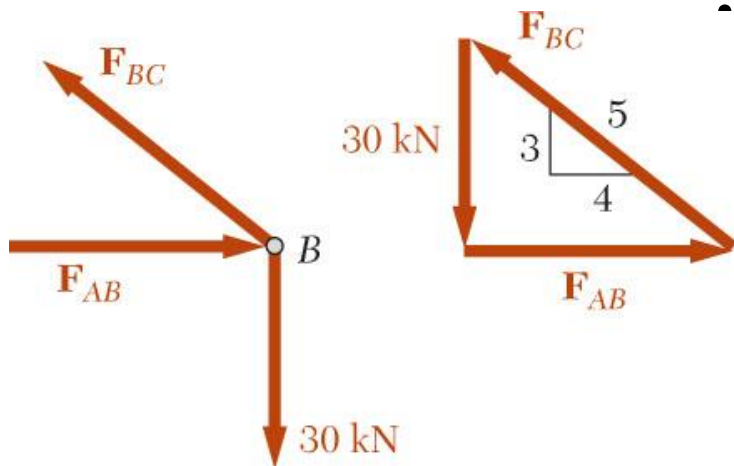

- Joints must satisfy the conditions for static equilibrium which may be expressed in the form of a force triangle:

$$\sum \vec{F}_B = 0$$

$$\frac{F_{AB}}{4} = \frac{F_{BC}}{5} = \frac{30\text{kN}}{3}$$

$$F_{AB} = 40\text{kN} \quad F_{BC} = 50\text{kN}$$

Stress Analysis

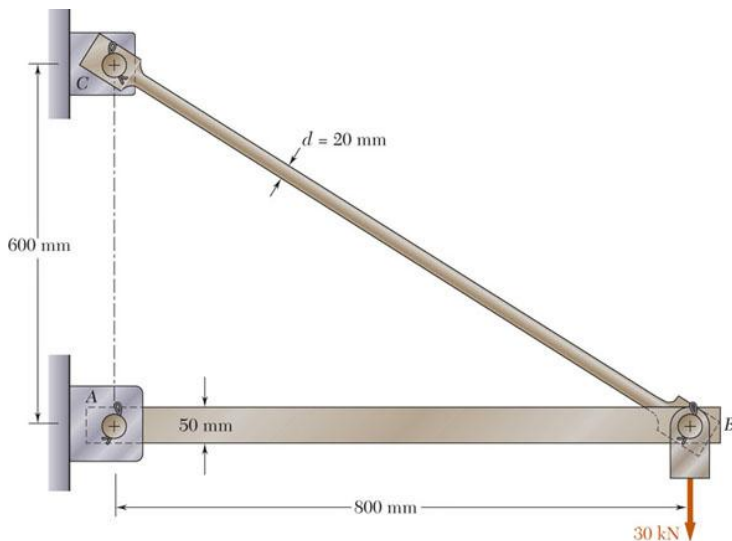

Can the structure safely support the 30 kN load?

- From a statics analysis

$$F_{AB} = 40 \text{ kN (compression)}$$

$$F_{BC} = 50 \text{ kN (tension)}$$

- At any section through member BC, the internal force is 50 kN with a force intensity or stress of

$$d_{BC} = 20 \text{ mm}$$

$$\sigma_{BC} = \frac{P}{A} = \frac{50 \times 10^3 \text{ N}}{314 \times 10^{-6} \text{ m}^2} = 159 \text{ MPa}$$

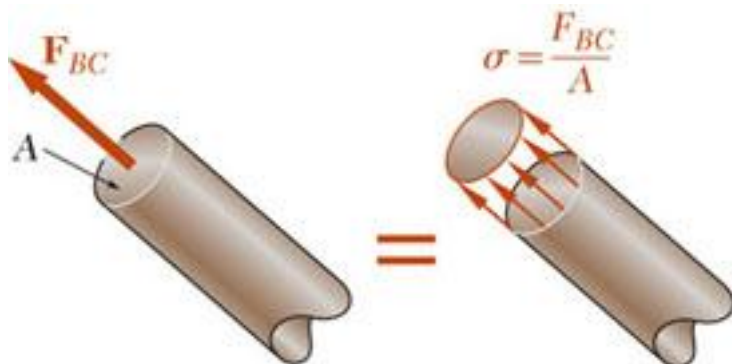

- From the material properties for steel, the allowable stress is

$$\sigma_{\text{all}} = 165 \text{ MPa}$$

- Conclusion: the strength of member BC is adequate

Design

- Design of new structures requires selection of appropriate materials and component dimensions to meet performance requirements
- For reasons based on cost, weight, availability, etc., the choice is made to construct the rod from aluminum ($\sigma_{all} = 100 \text{ MPa}$). What is an appropriate choice for the rod diameter?

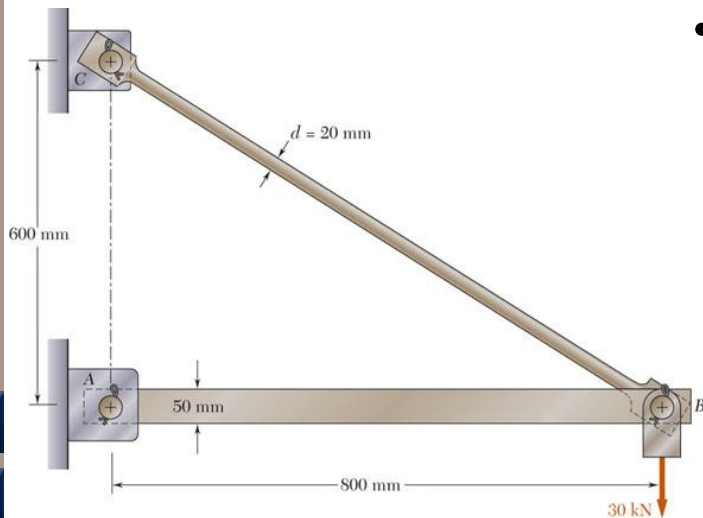

$$\sigma_{all} = \frac{P}{A} \quad A = \frac{P}{\sigma_{all}} = \frac{50 \times 10^3 \text{ N}}{100 \times 10^6 \text{ Pa}} = 500 \times 10^{-6} \text{ m}^2$$

$$A = \pi \frac{d^2}{4}$$

$$d = \sqrt{\frac{4A}{\pi}} = \sqrt{\frac{4(500 \times 10^{-6} \text{ m}^2)}{\pi}} = 2.52 \times 10^{-2} \text{ m} = 25.2 \text{ mm}$$

- An aluminum rod 26 mm or more in diameter is adequate

Axial Loading: Normal Stress

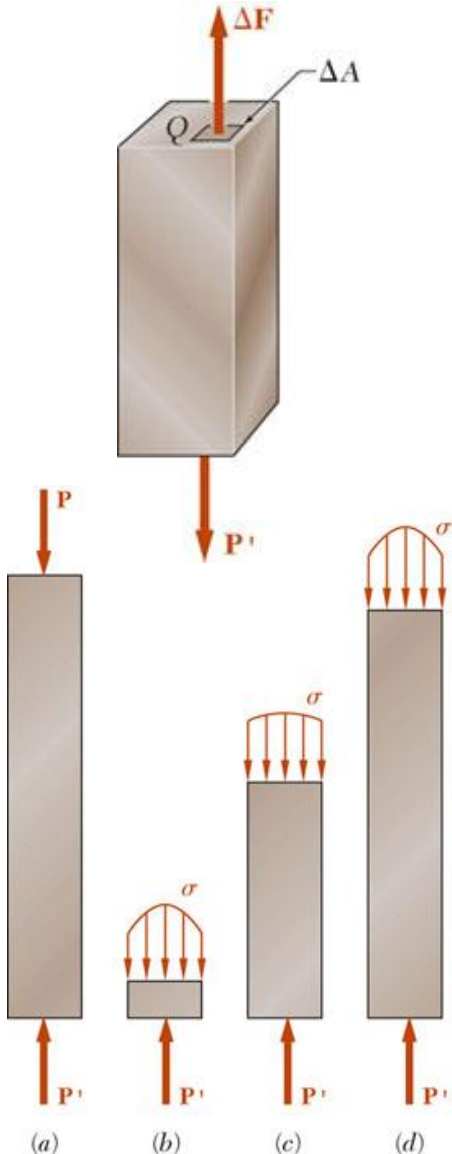

- The resultant of the internal forces for an axially loaded member is *normal* to a section cut perpendicular to the member axis.
- The force intensity on that section is defined as the normal stress.

$$\sigma = \lim_{\Delta A \rightarrow 0} \frac{\Delta F}{\Delta A} \quad \sigma_{ave} = \frac{P}{A}$$

- The normal stress at a particular point may not be equal to the average stress but the resultant of the stress distribution must satisfy

$$P = \sigma_{ave} A = \int dF = \int_A \sigma dA$$

- The detailed distribution of stress is statically indeterminate, i.e., can not be found from statics alone.

Centric & Eccentric Loading

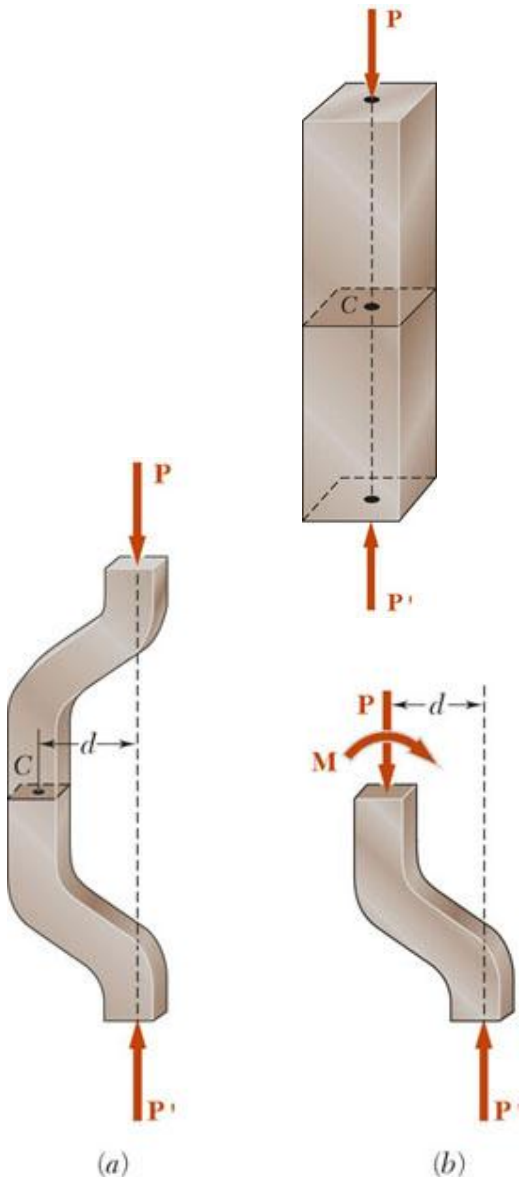

- A uniform distribution of stress in a section infers that the line of action for the resultant of the internal forces passes through the centroid of the section.
- A uniform distribution of stress is only possible if the concentrated loads on the end sections of two-force members are applied at the section centroids. This is referred to as *centric loading*.
- If a two-force member is *eccentrically loaded*, then the resultant of the stress distribution in a section must yield an axial force and a moment.
- The stress distributions in eccentrically loaded members cannot be uniform or symmetric.

Shearing Stress

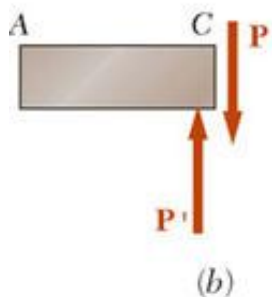
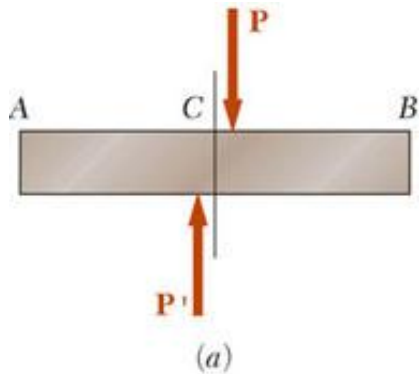
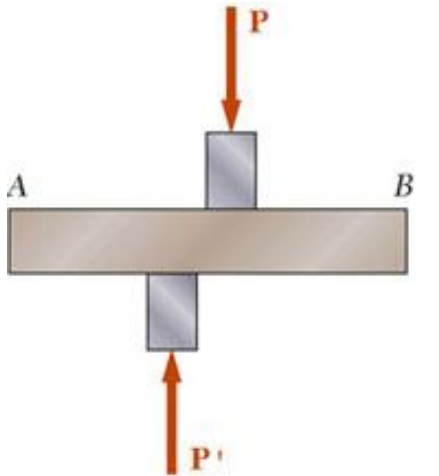

- Forces P and P' are applied transversely to the member AB .
- Corresponding internal forces act in the plane of section C and are called *shearing forces*.
- The resultant of the internal shear force distribution is defined as the *shear* of the section and is equal to the load P .
- The corresponding average shear stress is,

$$\tau_{\text{ave}} = \frac{P}{A}$$
- Shear stress distribution varies from zero at the member surfaces to maximum values that may be much larger than the average value.
- The shear stress distribution cannot be assumed to be uniform.

MECHANICS OF MATERIALS

Shearing Stress Examples

Single Shear

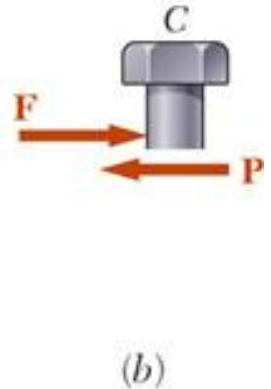
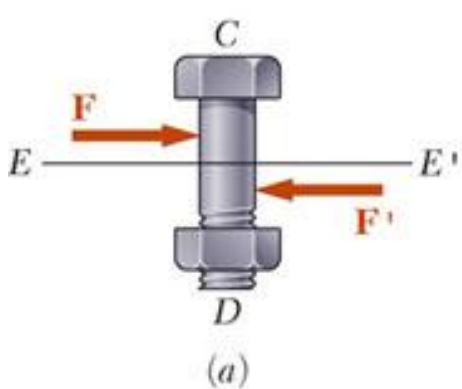
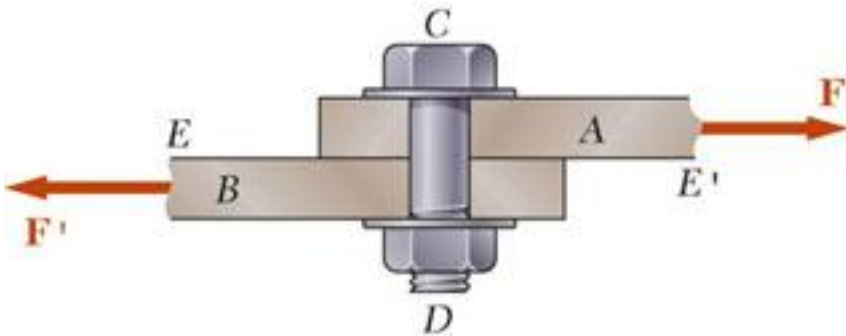

$$\tau_{ave} = \frac{P}{A} = \frac{F}{A}$$

Double Shear

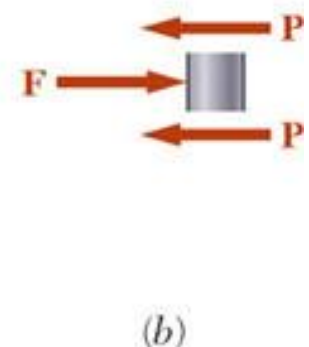
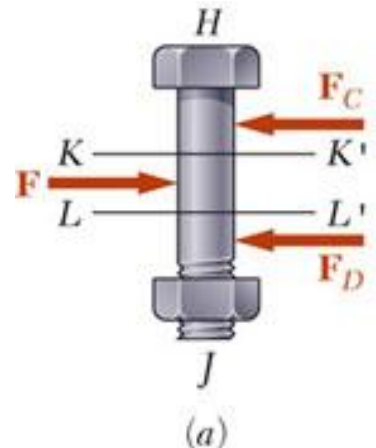
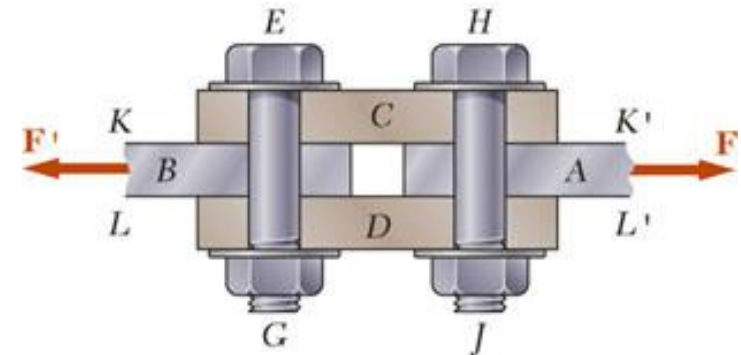

$$\tau_{ave} = \frac{P}{A} = \frac{F}{2A}$$



End

Bearing Stress in Connections

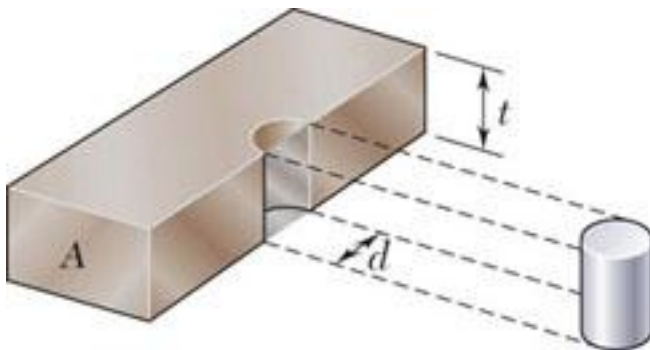
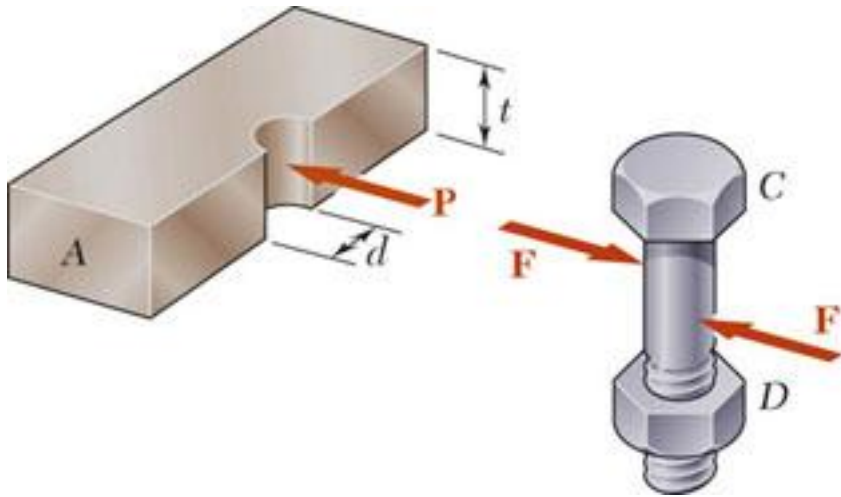

- Bolts, rivets, and pins create stresses on the points of contact or *bearing surfaces* of the members they connect.
- The resultant of the force distribution on the surface is equal and opposite to the force exerted on the pin.
- Corresponding average force intensity is called the bearing stress,

$$\sigma_b = \frac{P}{A} = \frac{P}{td}$$

Stress Analysis & Design Example

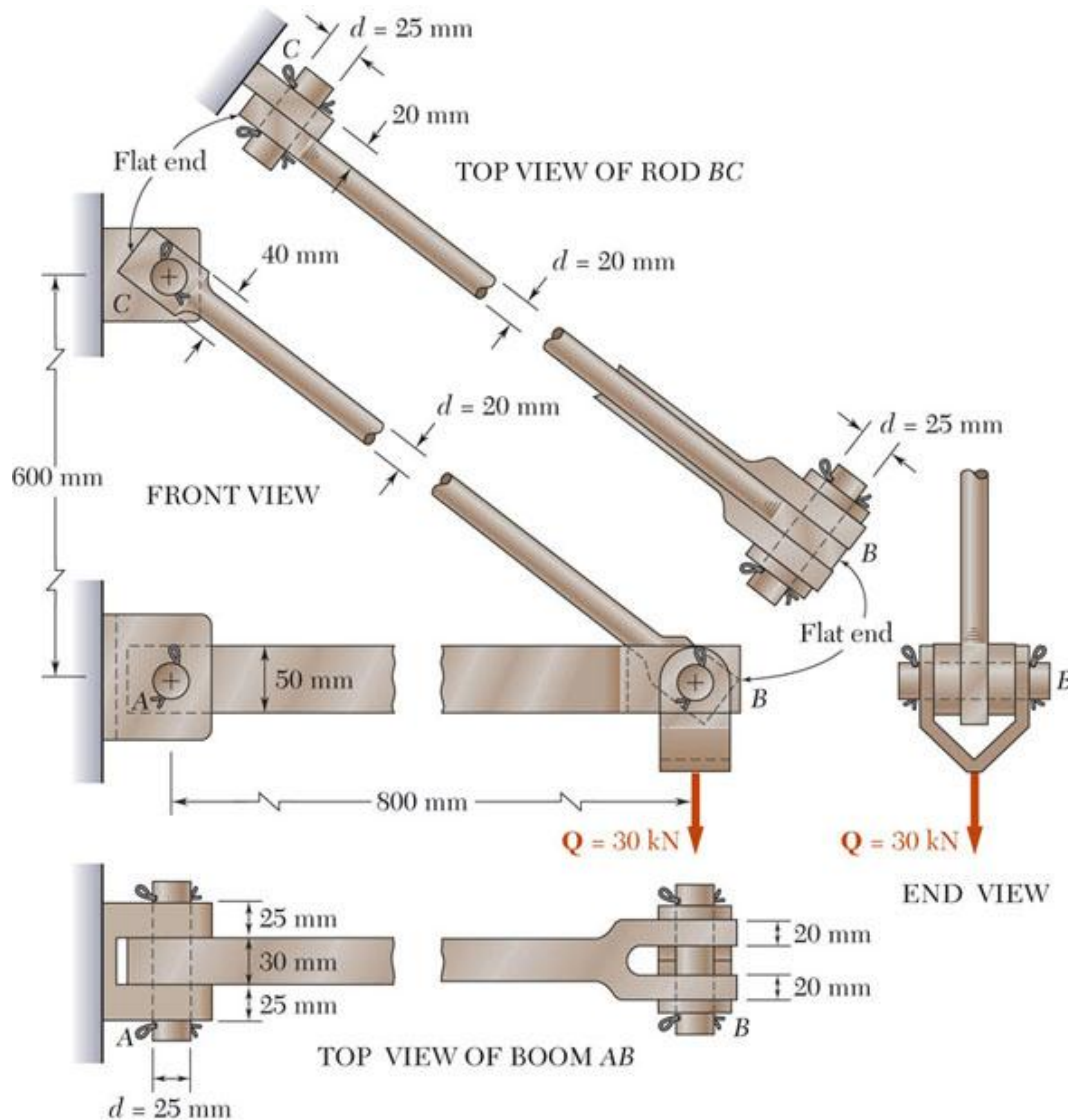

- Would like to determine the stresses in the members and connections of the structure shown.
- From a statics analysis:
 $F_{AB} = 40$ kN (compression)
 $F_{BC} = 50$ kN (tension)
- Must consider maximum normal stresses in AB and BC , and the shearing stress and bearing stress at each pinned connection

Rod & Boom Normal Stresses

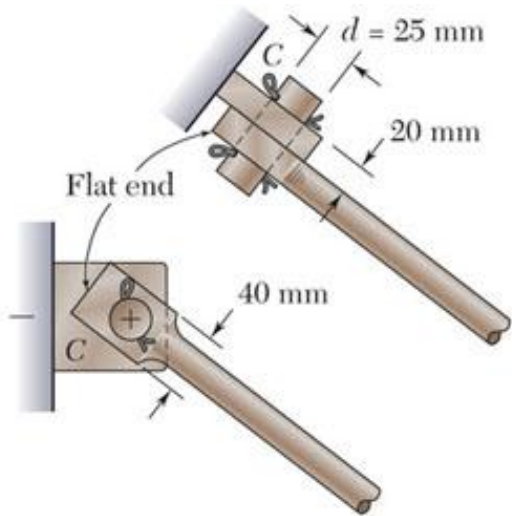

- The rod is in tension with an axial force of 50 kN.
- At the rod center, the average normal stress in the circular cross-section ($A = 314 \times 10^{-6} \text{m}^2$) is $\sigma_{BC} = +159 \text{ MPa}$.
- At the flattened rod ends, the smallest cross-sectional area occurs at the pin centerline,

$$A = (20 \text{ mm})(40 \text{ mm} - 25 \text{ mm}) = 300 \times 10^{-6} \text{m}^2$$

$$\sigma_{BC, \text{end}} = \frac{P}{A} = \frac{50 \times 10^3 \text{ N}}{300 \times 10^{-6} \text{m}^2} = 167 \text{ MPa}$$

- The boom is in compression with an axial force of 40 kN and average normal stress of -26.7 MPa .
- The minimum area sections at the boom ends are unstressed since the boom is in compression.

Pin Shearing Stresses

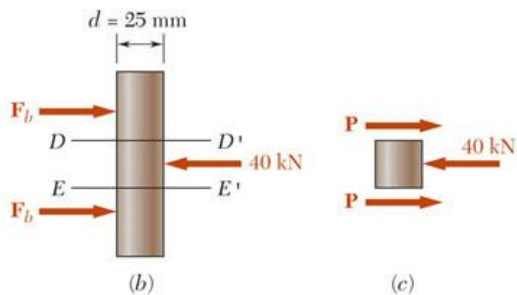
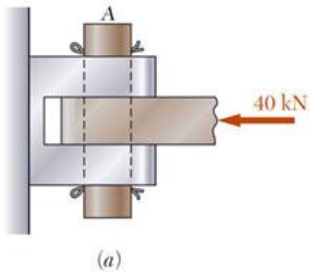
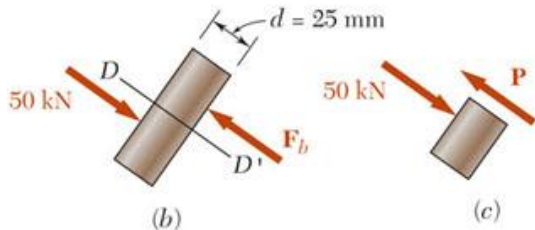
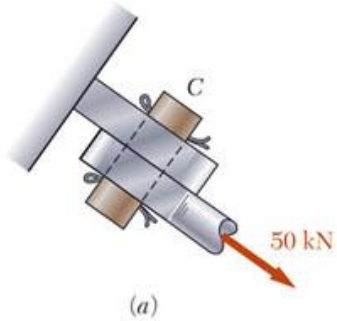

- The cross-sectional area for pins at A , B , and C ,

$$A = \pi r^2 = \pi \left(\frac{25 \text{ mm}}{2} \right)^2 = 491 \times 10^{-6} \text{ m}^2$$

- The force on the pin at C is equal to the force exerted by the rod BC ,

$$\tau_{C,ave} = \frac{P}{A} = \frac{50 \times 10^3 \text{ N}}{491 \times 10^{-6} \text{ m}^2} = 102 \text{ MPa}$$

- The pin at A is in double shear with a total force equal to the force exerted by the boom AB ,

$$\tau_{A,ave} = \frac{P}{A} = \frac{20 \text{ kN}}{491 \times 10^{-6} \text{ m}^2} = 40.7 \text{ MPa}$$

Pin Shearing Stresses

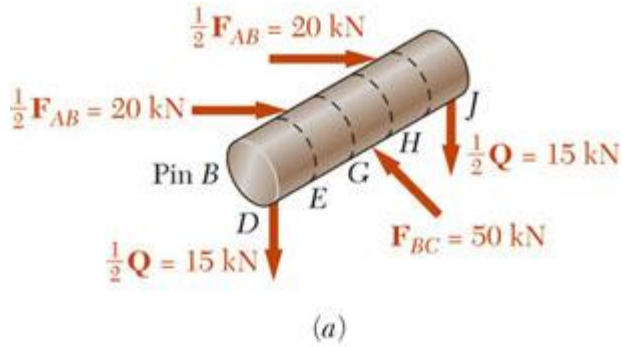

- Divide the pin at B into sections to determine the section with the largest shear force,

$$P_E = 15 \text{ kN}$$

$$P_G = 25 \text{ kN (largest)}$$

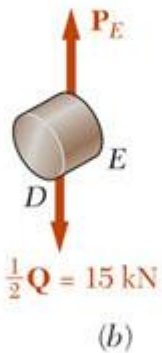

- Evaluate the corresponding average shearing stress,

$$\tau_{B,ave} = \frac{P_G}{A} = \frac{25 \text{ kN}}{491 \times 10^{-6} \text{ m}^2} = 50.9 \text{ MPa}$$

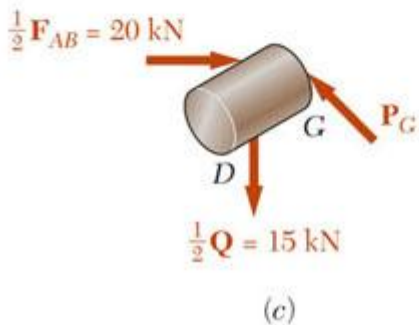

Pin Bearing Stresses

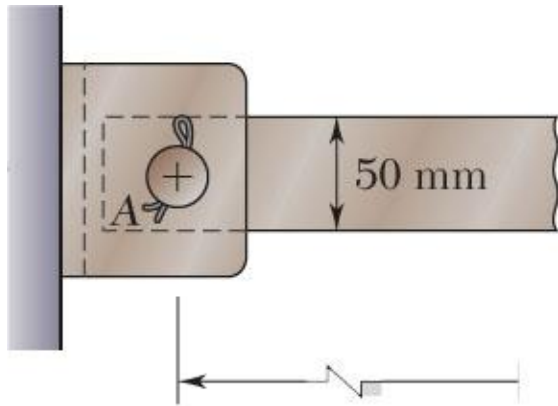

- To determine the bearing stress at A in the boom AB, we have $t = 30 \text{ mm}$ and $d = 25 \text{ mm}$,

$$\sigma_b = \frac{P}{td} = \frac{40 \text{ kN}}{(30 \text{ mm})(25 \text{ mm})} = 53.3 \text{ MPa}$$

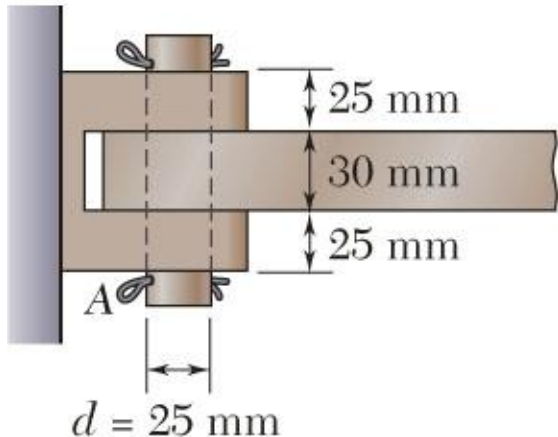

- To determine the bearing stress at A in the bracket, we have $t = 2(25 \text{ mm}) = 50 \text{ mm}$ and $d = 25 \text{ mm}$,

$$\sigma_b = \frac{P}{td} = \frac{40 \text{ kN}}{(50 \text{ mm})(25 \text{ mm})} = 32.0 \text{ MPa}$$

Stress in Two Force Members

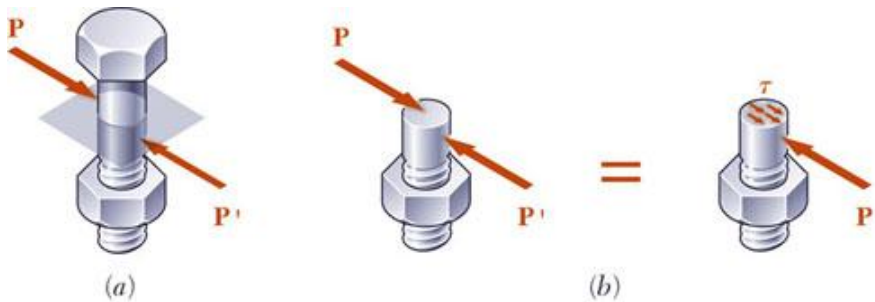
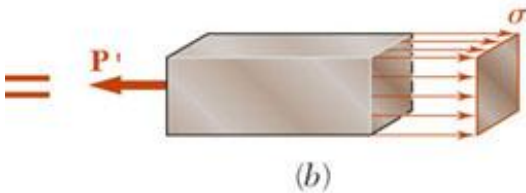
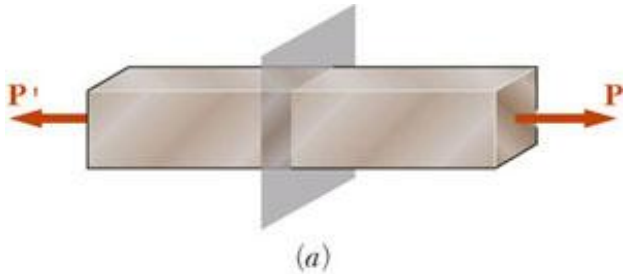

- Axial forces on a two force member result in only normal stresses on a plane cut perpendicular to the member axis.
- Transverse forces on bolts and pins result in only shear stresses on the plane perpendicular to bolt or pin axis.
- Will show that either axial or transverse forces may produce both normal and shear stresses with respect to a plane other than one cut perpendicular to the member axis.

Stress on an Oblique Plane

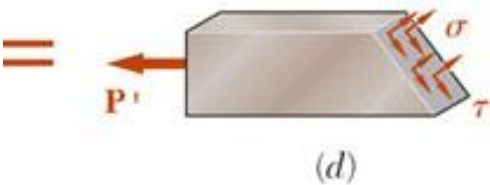
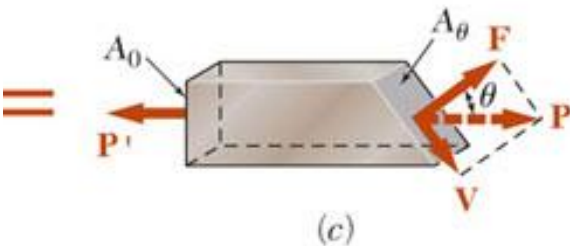
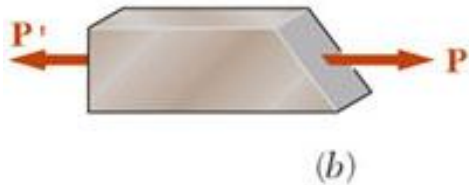
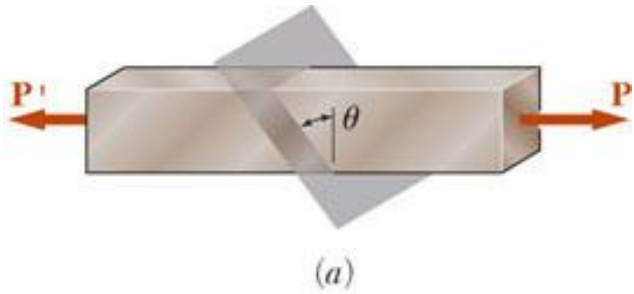

- Pass a section through the member forming an angle θ with the normal plane.
- From equilibrium conditions, the distributed forces (stresses) on the plane must be equivalent to the force P .
- Resolve P into components normal and tangential to the oblique section,

$$F = P \cos \theta \quad V = P \sin \theta$$
- The average normal and shear stresses on the oblique plane are

$$\sigma = \frac{F}{A_\theta} = \frac{P \cos \theta}{A_0 / \cos \theta} = \frac{P}{A_0} \cos^2 \theta$$

$$\tau = \frac{V}{A_\theta} = \frac{P \sin \theta}{A_0 / \cos \theta} = \frac{P}{A_0} \sin \theta \cos \theta$$

Maximum Stresses



(a) Axial loading



(b) Stresses for $\theta = 0$

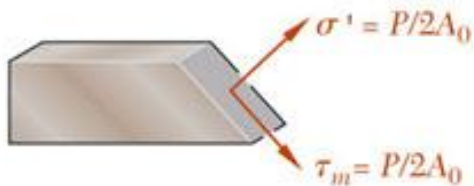

(c) Stresses for $\theta = 45^\circ$

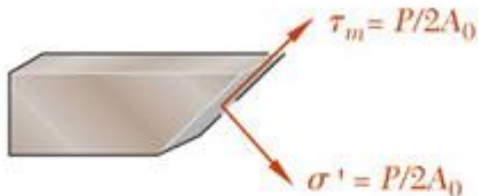

(d) Stresses for $\theta = -45^\circ$

- Normal and shearing stresses on an oblique plane

$$\sigma = \frac{P}{A_0} \cos^2 \theta \quad \tau = \frac{P}{A_0} \sin \theta \cos \theta$$

- The maximum normal stress occurs when the reference plane is perpendicular to the member axis,

$$\sigma_m = \frac{P}{A_0} \quad \tau' = 0$$

- The maximum shear stress occurs for a plane at $\pm 45^\circ$ with respect to the axis,

$$\tau_m = \frac{P}{A_0} \sin 45 \cos 45 = \frac{P}{2A_0} = \sigma'$$

Stress Under General Loadings

- A member subjected to a general combination of loads is cut into two segments by a plane passing through Q
- The distribution of internal stress components may be defined as,

$$\sigma_x = \lim_{\Delta A \rightarrow 0} \frac{\Delta F^x}{\Delta A}$$

$$\tau_{xy} = \lim_{\Delta A \rightarrow 0} \frac{\Delta V_y^x}{\Delta A} \quad \tau_{xz} = \lim_{\Delta A \rightarrow 0} \frac{\Delta V_z^x}{\Delta A}$$

- For equilibrium, an equal and opposite internal force and stress distribution must be exerted on the other segment of the member.

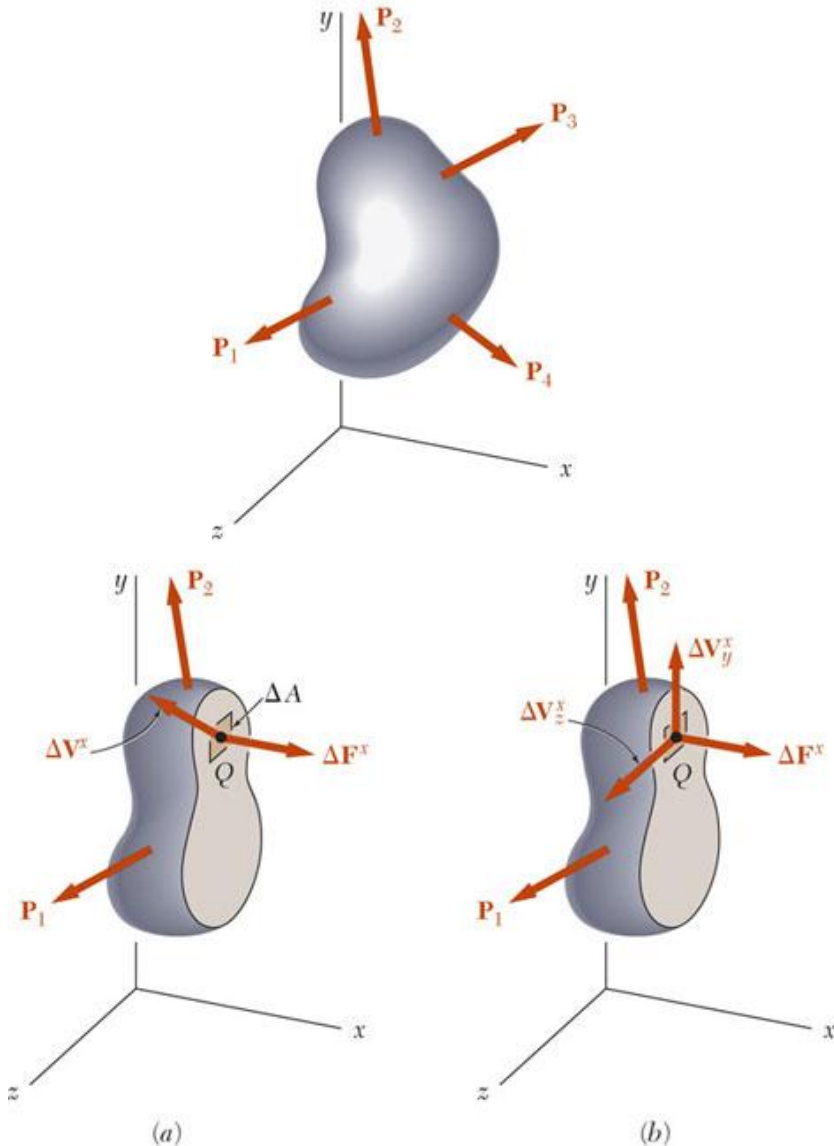

State of Stress

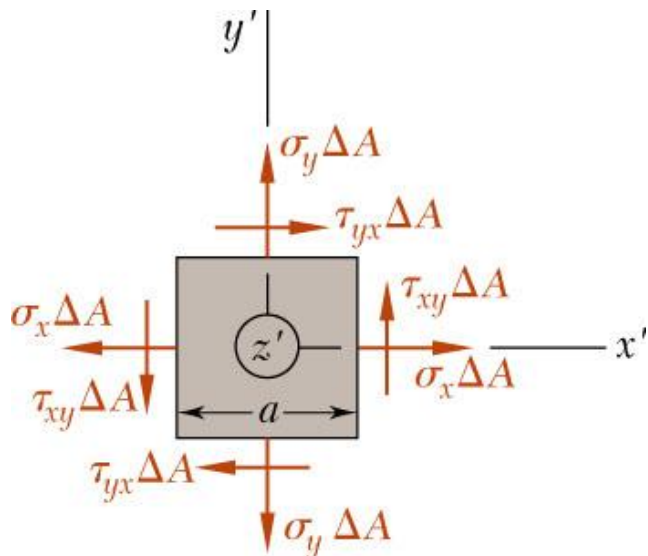
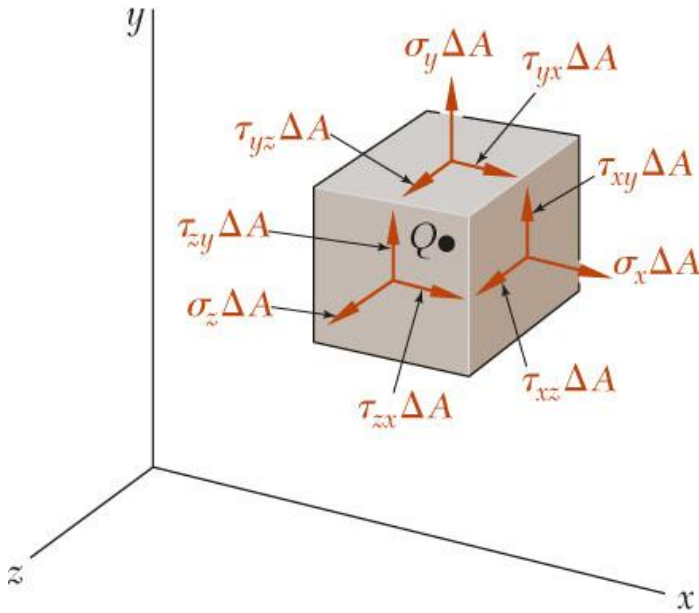

- Stress components are defined for the planes cut parallel to the x , y and z axes. For equilibrium, equal and opposite stresses are exerted on the hidden planes.

- The combination of forces generated by the stresses must satisfy the conditions for equilibrium:

$$\sum F_x = \sum F_y = \sum F_z = 0$$

$$\sum M_x = \sum M_y = \sum M_z = 0$$

- Consider the moments about the z axis:

$$\sum M_z = 0 = (\tau_{xy}\Delta A)a - (\tau_{yx}\Delta A)a$$

$$\tau_{xy} = \tau_{yx}$$

$$\text{similarly, } \tau_{yz} = \tau_{zy} \quad \text{and} \quad \tau_{xz} = \tau_{zx}$$

- It follows that only 6 components of stress are required to define the complete state of stress

Factor of Safety

Structural members or machines must be designed such that the working stresses are less than the ultimate strength of the material.

FS = Factor of safety

$$FS = \frac{\sigma_u}{\sigma_{all}} = \frac{\text{ultimate stress}}{\text{allowable stress}}$$

Factor of safety considerations:

- uncertainty in material properties
- uncertainty of loadings
- uncertainty of analyses
- number of loading cycles
- types of failure
- maintenance requirements and deterioration effects
- importance of member to integrity of whole structure
- risk to life and property
- influence on machine function