

**Department of Physics**  
**PCS 211 – Physics: Mechanics**

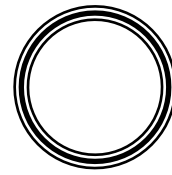

Please insert in the circle the  
initial of your last name

**Please Print Clearly:**

**Student:** \_\_\_\_\_  
*Last Name* *First Name*

**Student Number:** \_\_\_\_\_ **Student Section:** \_\_\_\_\_

## Final Exam – December 9, 2011

**Check the name of your professor:**

Dr. Chithrani

Dr. Hu

Dr. Tavakkoli

Dr. Toronov

Dr. Yuan

**Read the following attentively**

- **Ensure that your name and student number are correct in the bubble sheet.**
- **Duration of the exam is 170 minutes.**
- **The exam consists of 25 multiple-choice questions. Answer ALL questions.**
- **Each question has 1 mark.**
- **For each multiple choice question:**
  - You need to show, in the space provided in this booklet, a justification for your answer. If no work or correct argument is shown, the resultant mark may be zero, even if the answer in the bubble sheet is correct.
  - The work shown in your exam booklet may be checked, **at least for one** of the questions, selected randomly.
  - **Transfer your choices to the bubble sheet only when you're sure of them.**
  - Some answers may be rounded off.
- **Pagers and cell phones must be silenced and placed out of reach. Hats and earphones are not allowed. If a phone rings, its owner is responsible for disrupting the exam and the phone will be confiscated or the owner will be asked to leave the room resulting in a zero on the test.**
- **Sharing of pencils, erasers and calculators is not permitted.**
- **Talking to another student or glancing over another student's paper is not permitted and may result in a charge of academic misconduct.**
- **The calculator models allowed for the test are either Sharp EL-546 or Casio FX-991 (or versions of these models). If you are found to have another type of calculator, it may be confiscated for the duration of the test.**
- **The exam booklet has a total of 12 pages. You are responsible for checking that you have all pages.**

---

*Sign here to signify you read the instructions*

## Problems

1. Find the vector resultant of three displacements having  $x$  and  $y$  components (3.00, 2.00) m, (-5.00, 3.00) m, and (6.00, 1.00) m.

- (a)  $4.00\mathbf{i} + 2.00\mathbf{j}$  m
- (b)  $-5.00\mathbf{i} + 3.00\mathbf{j}$  m
- (c)  $4.00\mathbf{i} + 6.00\mathbf{j}$  m
- (d)  $6.00\mathbf{i} + 1.00\mathbf{j}$  m
- (e) None of the above

2. What is the angle (in degrees) between the direction of the force and the direction of the section  $AB$  of the pipe?

- (a) 30
- (b) 43
- (c) 25
- (d) 59
- (e) None of the above

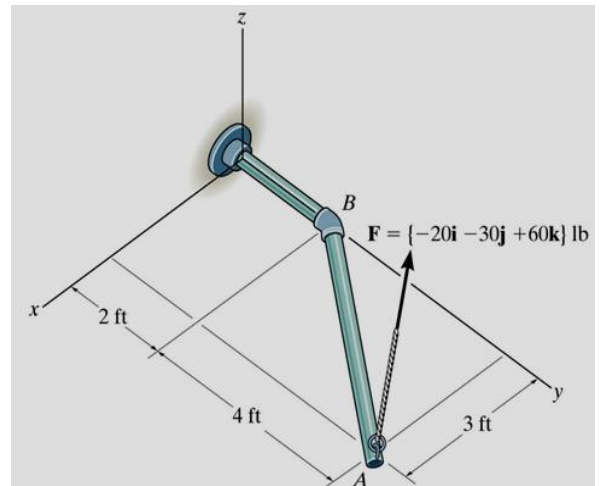

3. A 600 N load is supported by three cords with the geometry as shown. The tensions in cords  $AB$ ,  $AC$  and  $AD$  are respectively:

- (a) 693 N, 646 N, 900 N
- (b) 900 N, 646 N, 693 N
- (c) 693 N, 900 N, 646 N
- (d) 646 N, 693 N, 900 N
- (e) None of the above

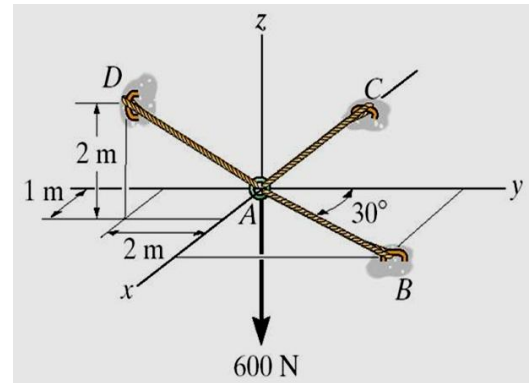

4. A force is applied to the tool to open a gas valve. The magnitude of the moment of this force about the  $z$  axis is

- (a) 40 N.m
- (b) 33.3 N.m
- (c) 50 N.m
- (d) 25.5 N.m
- (e) 15.5 N.m

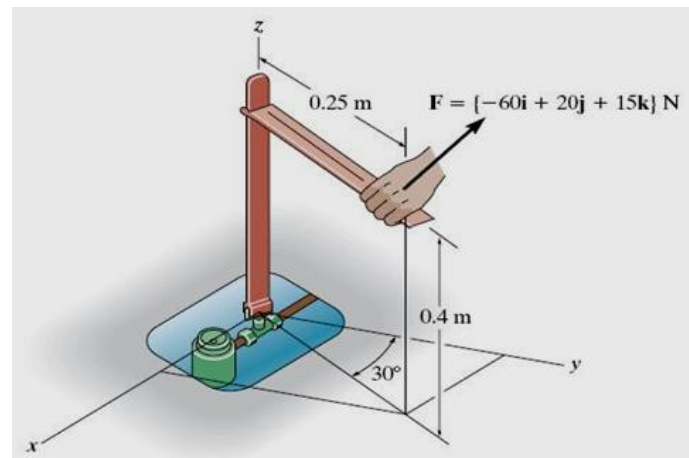

5. The combined mass of wheelbarrow and load is 110 kg with center of mass at  $G$ . Determine the magnitude  $P$  of the vertical force required to lift the wheelbarrow free of the ground at point  $B$ .

- (a) 156.2 N
- (b) 125.0 N
- (c) 179.7 N
- (d) 110 N
- (e) 96.8 N

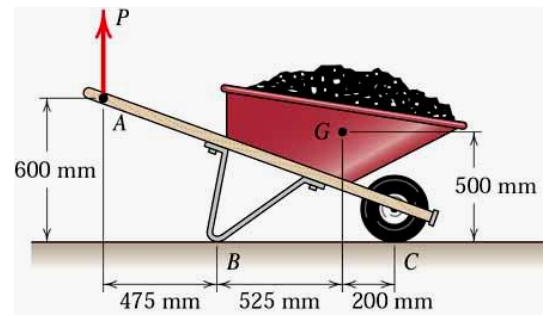

6. Determine the horizontal and vertical components ( $A_x, A_y$ ) of reaction at pin  $A$  to support the steel frame.

- (a) (10.8, 47.7) kN
- (b) (10.8, 20.8) kN
- (c) (20.8, 10.8) kN
- (d) (47.7, 87.7) kN
- (e) (20.8, 87.7) kN

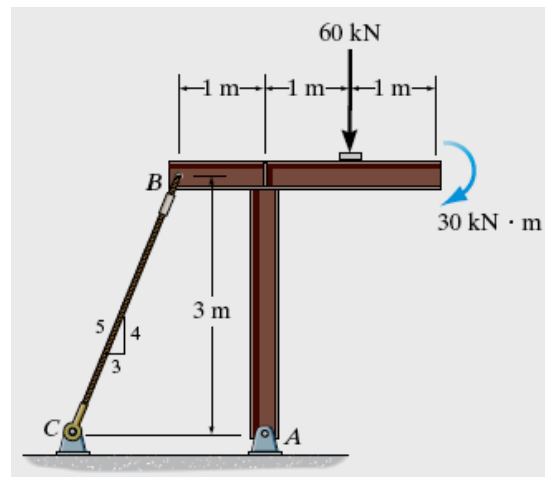

7. A uniform piece of steel is shaped as shown in dark color. What are the coordinates of the center of mass of the piece  $(x_M, y_M)$ ?

- (a) (11.7, 13.3) cm
- (b) (11.7, 16.6) cm
- (c) (15.2, 16.6) cm
- (d) (15.2, 13.3) cm
- (e) (13.3, 15.2) cm

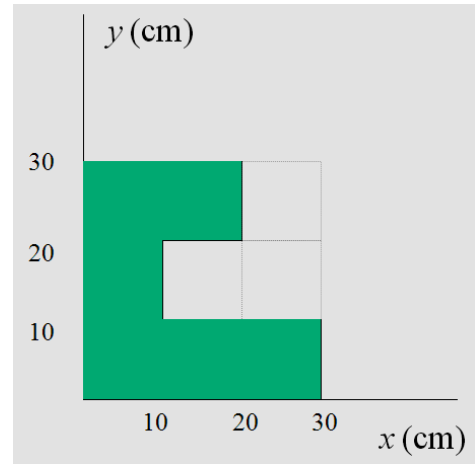

8. A small solid sphere is fired into a viscous medium with an initial speed of 27 m/s. If it experiences a rectilinear motion with deceleration of  $a = (-6t) \text{ m/s}^2$ , where  $t$  is in seconds, find the distance traveled before it stops.

- (a) 108 m
- (b) 81 m
- (c) 54 m
- (d) 18 m
- (e) None of the above

9. A car starts from rest and moves with a constant acceleration of  $1.5 \text{ m/s}^2$  until it achieves a velocity of  $24 \text{ m/s}$ . It then travels with constant velocity for 60 seconds. Determine the average speed of the car for the entire motion.

- (a) 12 m/s
- (b) 27.2 m/s
- (c) 21.5 m/s
- (d) 18.9 m/s
- (e) None of the above

10. The motions of particles A and B are described by the position vectors of  $\mathbf{r}_A = [6t \mathbf{i} + t(3 - t) \mathbf{j}] \text{ m}$  and  $\mathbf{r}_B = [3(t^2 - 3t + 4) \mathbf{i} + (t - 8) \mathbf{j}] \text{ m}$ . Find the speed of particle A just before the particles collide.

- (a) 3.3 m/s
- (b) 6.1 m/s
- (c) 9.2 m/s
- (d) 7.8 m/s
- (e) 15 m/s

**11.** It is observed that the time for the ball to strike the ground at  $B$  is 2.5 s. Determine the angle  $\theta_A$  at which the ball was thrown.

- (a)  $32.5^\circ$
- (b)  $59.5^\circ$
- (c)  $30.5^\circ$
- (d)  $57.5^\circ$
- (e) None of the above

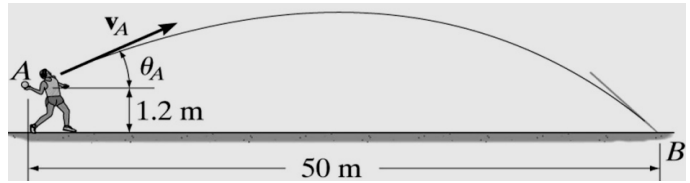

**12.** The truck travels at a speed of 4 m/s along a circular road that has a radius of 50 m. For a short distance from  $s = 0$ , its speed is then increased by  $a_t = (0.05s) \text{ m/s}^2$ , where  $s$  is in meters. Determine the magnitude of its acceleration when it has moved  $s = 10 \text{ m}$ .

- (a)  $0.43 \text{ m/s}^2$
- (b)  $0.27 \text{ m/s}^2$
- (c)  $0.50 \text{ m/s}^2$
- (d)  $0.92 \text{ m/s}^2$
- (e)  $0.65 \text{ m/s}^2$

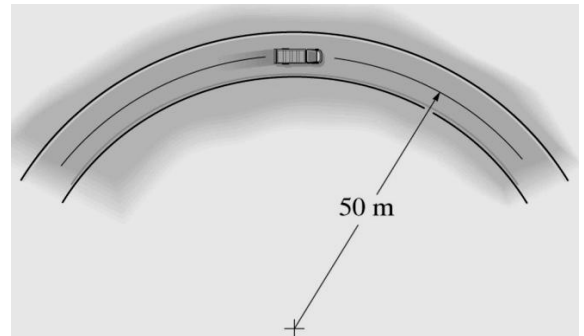

13. Determine the tension  $P$  in the cable that will give the 50 kg block a steady acceleration of  $2.0 \text{ m/s}^2$  up the incline.

- (a) 147 N
- (b) 129 N
- (c) 455 N
- (d) 359 N
- (e) 227 N

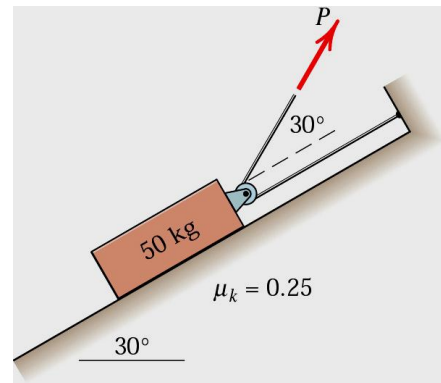

14. At the instant when  $\theta = 60^\circ$ , the boy's center of mass  $G$  has a speed of 15 ft/s. The boy has a weight of 60 lb. Neglect his size and the mass of the seat and cords. Find the tension in each of the two supporting cords.

- (a) 47 lb
- (b) 36 lb
- (c) 51 lb
- (d) 26 lb
- (e) 21 lb

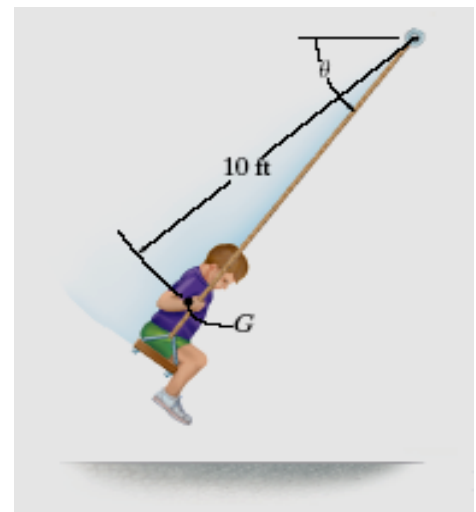

**15.** The man at the window wishes to throw the 30 kg sack on the ground. To do this he allows it to swing from rest at  $B$  to point  $C$ , when he releases the cord at  $\theta = 30^\circ$ . Determine the speed at which it strikes the ground.

- (a) 23.3 m/s
- (b) 32.6 m/s
- (c) 27.0 m/s
- (d) 17.7 m/s**
- (e) 28.9 m/s

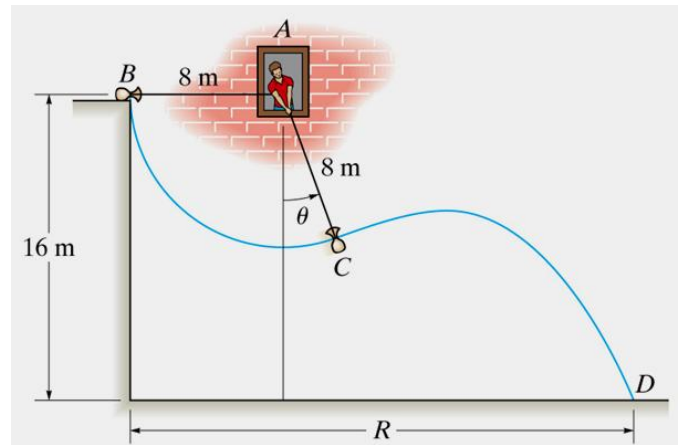

**16.** The collar has a mass of 30 kg and is supported on the rod having a coefficient of kinetic friction of 0.4. The spring has an unstretched length of 0.2 m and a stiffness of 50 N/m. Determine the speed of the collar after the applied force  $F$  causes it to be displaced  $s = 1.5$  m from point  $A$ . When  $s = 0$  the collar is kept at rest.

- (a) 3.0 m/s
- (b) 3.6 m/s
- (c) 4.4 m/s
- (d) 1.7 m/s**
- (e) 1.3 m/s

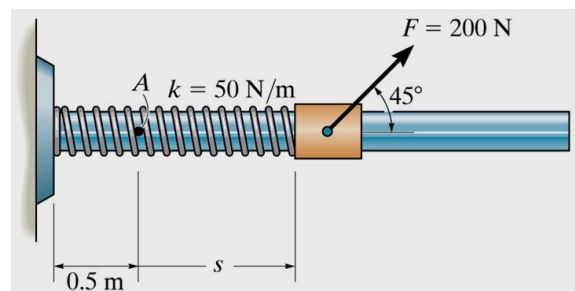

17. The skier of mass 70 kg starts from rest at A and travels down the ramp. If friction and air resistance can be neglected, determine his speed when he reaches B.

- (a) 18.0 m/s
- (b) 30.0 m/s**
- (c) 110 m/s
- (d) 12.5 m/s
- (e) 200 m/s

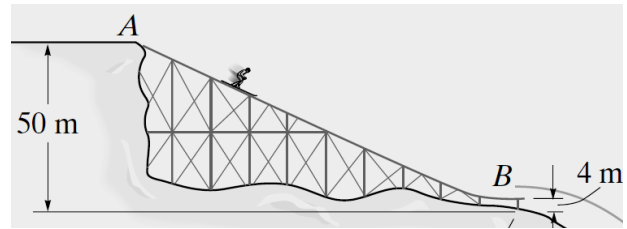

18. Roller coasters are designed so that riders will not experience a normal force that is more than 3.5 times their weight against the seat of the car. Determine the smallest radius of curvature  $\rho$  of the track at its lowest point if the car has a speed of 5 ft/s at the crest (top point) of the drop. Neglect friction.

- (a) 12.1 ft
- (b) 88.3 ft**
- (c) 112 ft
- (d) 31.5 ft
- (e) 10.0 ft

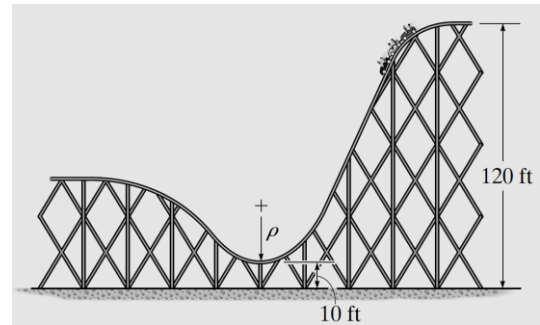

19. The force acting on a projectile of a mass 1 kg as it passes horizontally through the barrel of the cannon is  $F = \{31.4 \sin(100\pi t)\}$  kN. Determine the projectile's velocity when  $t=0.01$  s.

- (a) 200 m/s
- (b) 518 m/s
- (c) 1.10 km/s
- (d) 3.14 km/s
- (e) 100 m/s

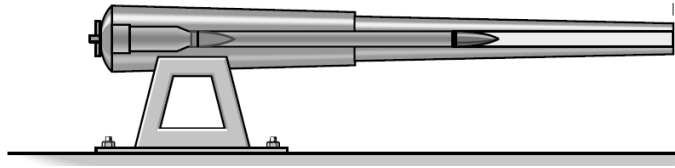

20. The car A has a weight of 4500 lb and is traveling to the right at 3 ft/s. Meanwhile a 3000-lb car B is traveling at 6 ft/s to the left. If the cars crash head-on and become entangled, determine their common velocity just after the collision. Assume that the brakes are not applied during the collision.

- (a) 3.00 ft/s to the right
- (b) 0.02 ft/s to the left
- (c) 0.60 ft/s to the left
- (d) 3.02 m/s to the right
- (e) 1.31 m/s to the left

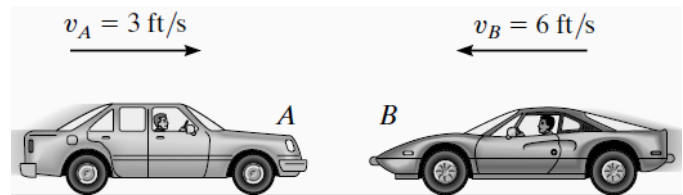

## Short-answer Questions

21. Which statement is always true for an object in equilibrium?
- (a) It does not move.
  - (b) It does not accelerate.**
  - (c) There are no forces acting on it.
  - (d) There are no moments acting on it.
  - (e) None of the above.
22. If a block is moving on a fixed surface, then the friction force acting on it is always:
- (a)  $> \mu_k N$
  - (b)  $= \mu_s N$
  - (c)  $\geq \mu_s N$
  - (d)  $= \mu_k N$**
  - (e)  $\leq \mu_k N$
23. A ball is hit upward and travels along a parabolic arc before it strikes the ground. Which one of the following statements is necessarily true?
- (a) The acceleration of the ball decreases as the ball moves upward.
  - (b) The velocity of the ball is zero when the ball is at the highest point in the arc.
  - (c) The acceleration of the ball is zero when the ball is at the highest point in the arc.
  - (d) The velocity of the ball is a maximum when the ball is at the highest point in the arc.
  - (e) The  $x$ -component of the velocity of the ball is the same throughout the ball's flight.**
24. Compared to the amount of energy required to accelerate a car from rest to 10 miles per hour, the amount of energy required to accelerate the same car from 10 to 20 miles per hour is
- (a) the same
  - (b) twice as much
  - (c) three times as much**
  - (d) four times as much
  - (e) none of the above
25. Three identical balls are thrown from the top of a building, all with the same initial speed. Ball 1 is thrown horizontally, ball 2 at some angle below the horizontal, and ball 3 vertically down. Neglecting air resistance, rank the speeds of the balls as they reach the ground, from fastest to slowest.
- (a) 1, 2, 3
  - (b) 2, 1, 3
  - (c) 3, 1, 2
  - (d) 3, 2, 1
  - (e) All three balls strike the ground at the same speed**

$1 \text{ ft} = 0.3048 \text{ m}$
$1 \text{ in} = (1/12) \text{ ft}$
$1 \text{ lb} = 4.4482 \text{ N}$
$1 \text{ slug} = 14.594 \text{ kg}$
$g = 9.81 \text{ m/s}^2$
$= 32.2 \text{ ft/s}^2$