

RL

CARLETON UNIVERSITY

Mechanics of Solids I  
**FINAL EXAMINATION**  
December 6, 2008

**DURATION:** 3 HOURS

No. of Students: 110

Department Name & Course Name: MAAE 2202 A

Course Instructor Professor R. LIU

AUTHORIZED MEMORANDA

Calculator and Course Notes only

Students **MUST** count the number of pages in this examination question paper **before** beginning to write and report any discrepancy immediately to a proctor. This question paper has 6 pages.

This examination question paper may be taken from the examination room.

Booklets.

Note: Answer **ALL** questions.

HS  
KQ

**Question 1 (15%)**

In the structure of Fig. 1, determine the resultant internal loads acting on the cross section of the frame at points  $F$  and  $G$ . Also determine the contact force at  $E$ , assuming the contact at  $E$  is smooth. If the diameter of the pin at  $D$  is 4 mm, compute the shear stress of the pin. The cross-sectional area of member  $AC$  is  $20 \text{ mm}^2$ , what is the value of the stress in the member? Is it tensile or compressive? The member  $AC$  is made of steel with the Young's modulus of 210 GPa; calculate the deformation of the member. The external load of 400 N is applied perpendicularly to member  $DEF$ .

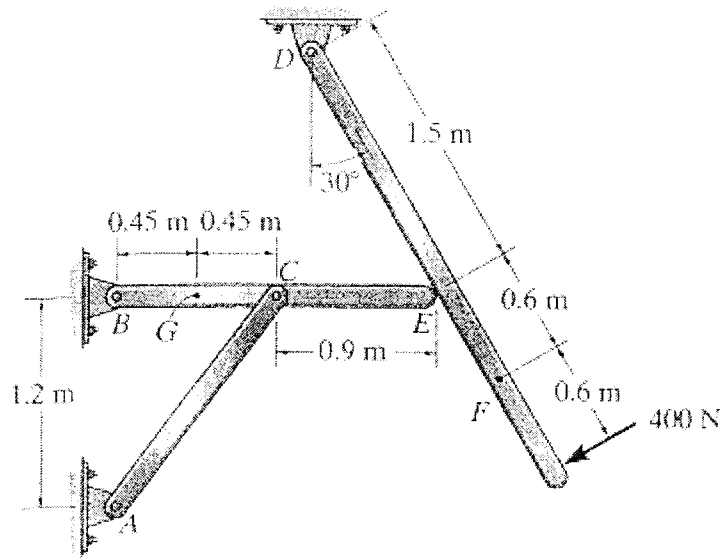

**Fig. 1**

45  
R.

**Question 2 (20%)**

A load of 2.5 kN is supported by four stainless steel ( $E = 200$  GPa) wires that are connected to the rigid members  $AB$  and  $DC$ , as shown in Fig. 2. Determine the vertical displacement of the loading point  $I$ . The members were horizontal before loading. Each wire has a uniform cross-sectional area of  $16 \text{ mm}^2$ . Also determine the angle of tilt of each member under the load.

**(Hint:** Consider force equilibrium of rigid members  $AB$  and  $DC$ , respectively, to obtain the internal force of each wire; then evaluate the deformation of each wire to find the vertical displacement of the loading point  $I$ .)

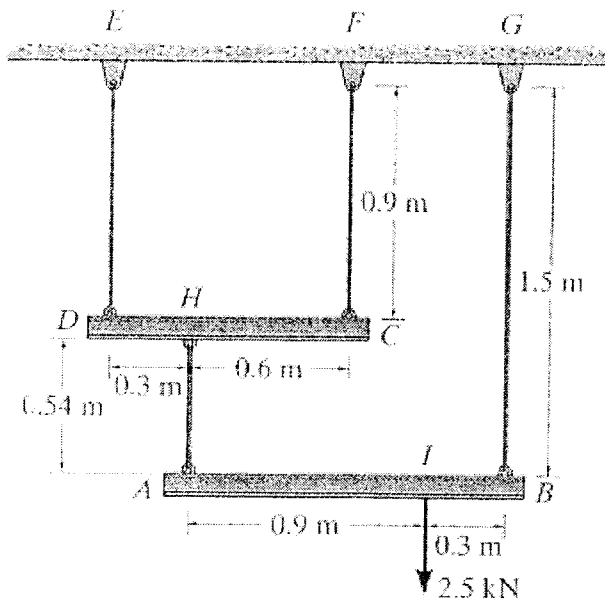
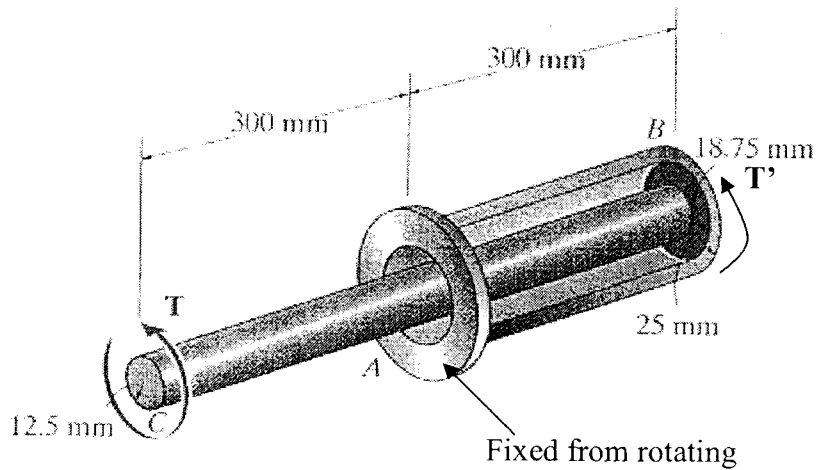

**Fig. 2**

HS  
KL

**Question 3 (15%)**

The device in Fig. 3 serves as a compact torsion spring. It is made of steel with  $G = 75$  GPa and consists of a solid inner shaft  $CB$  which is surrounded by and attached to a tube  $AB$  using a rigid ring at  $B$ . The ring at  $A$  is also rigid and is fixed from rotating. A torque of  $T = 0.25$  kN.m is applied to the shaft at  $C$  and another torque  $T'$  is applied at the shaft-tube joint  $B$  in the same direction to  $T$ . Determine the maximum shear stress and the maximum twist angle of shaft  $CB$ . If the allowable shear stress for tube  $AB$  is limited to 84 MPa and the twist angle to  $2^\circ$ , determine the maximum value of torque  $T'$  that can be applied. The radius of the shaft  $CB$  is 12.5 mm, and the inner radius and outer radius of the tube  $AB$  are 18.75 mm and 25 mm, respectively.



**Fig. 3**

RP  
HS  
RL

**Question 4 (20%)**

The wood beam in Fig. 4 is subjected to the uniform load of  $w = 5 \text{ kN/m}$  and a concentrated load  $P = 20 \text{ kN}$ . Draw shear force and bending moment diagrams for the given beam. If the allowable bending stress for the material is  $\sigma_{allow} = 80 \text{ MPa}$ , determine the required dimension  $b$  of its cross section. Assume the support at  $A$  is a pin and  $B$  is a roller.

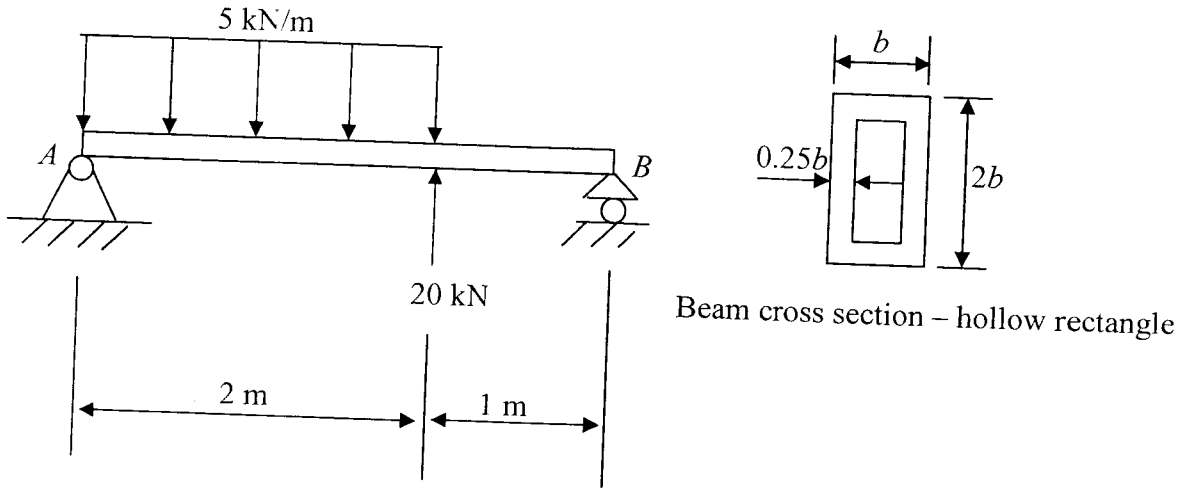

Fig. 4

**Question 5 (15%)**

For the beam in Fig. 5, determine the slopes at  $B$  and  $D$ , and the displacements at  $A$  and  $C$ . The member is steel with  $E = 200 \text{ GPa}$  and  $I = 10^8 \text{ mm}^4$ .

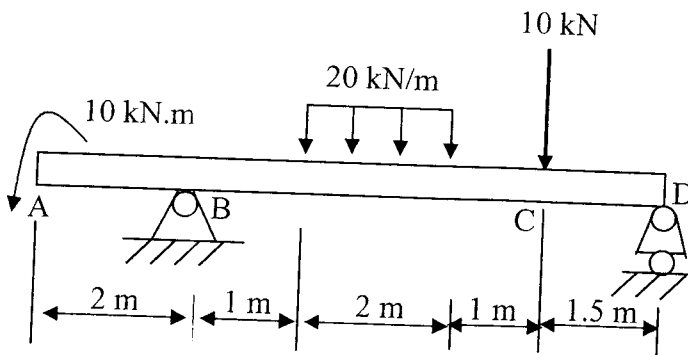
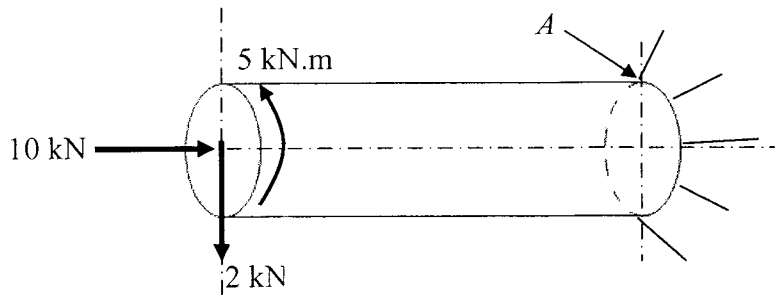

Fig. 5

HS  
RL

**Question 6 (15%)**

The solid shaft with one end fixed is subjected to a torque of 5 kN.m, an axial force of 10 kN, and a transverse force of 2 kN, as shown in Fig. 6. Determine the principal stresses and the maximum shear stress acting at point *A*. Also present these stresses on the stress Mohr's circle. The radius and the length of the shaft are 50 mm and 1 m, respectively.



**Fig. 6**