

CHAPTER 7

Applications of Vectors

Review of Prerequisite Skills, p. 350

1. The velocity relative to the ground has a magnitude equivalent to the hypotenuse of a triangle with sides 800 and 100. So, by the Pythagorean theorem we can find the magnitude of the velocity.

$$\begin{aligned} v^2 &= 800^2 + 100^2 \\ &= 640\,000 + 10\,000 \\ &= 650\,000 \\ v &= \sqrt{650\,000} \\ &\doteq 806 \text{ km/h} \end{aligned}$$

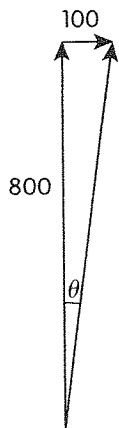

$$\begin{aligned} \tan \theta &= \frac{100}{800} \\ \theta &= \tan^{-1} \left(\frac{100}{800} \right) \end{aligned}$$

$$\theta \doteq 7.1^\circ$$

The velocity of the airplane relative to the ground is about 806 km/h N 7.1° E.

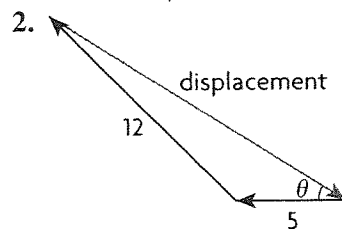

The angle between the two displacements is 135° . The magnitude, m , and the angle, θ , of the displacement can be found using the cosine law.

$$\begin{aligned} m^2 &= 5^2 + 12^2 - 2(5)(12)\cos 135 \\ &= 25 + 144 - 120\left(\frac{-\sqrt{2}}{2}\right) \\ &= 169 + 84.85 \\ &= 253.85 \\ m &= \sqrt{253.85} \\ &\doteq 15.93 \text{ units} \\ 12^2 &= 15.93^2 + 5^2 - 2(15.93)(5)\cos \theta \\ 144 &= 253.76 + 25 - 159.3\cos \theta \\ -134.76 &= -159.3\cos \theta \\ \cos \theta &= \frac{134.76}{159.3} \\ \theta &= \cos^{-1} \left(\frac{134.76}{159.3} \right) \\ &\doteq 32.2^\circ \end{aligned}$$

So the displacement is 15.93 units, W 32.2° N.

3.

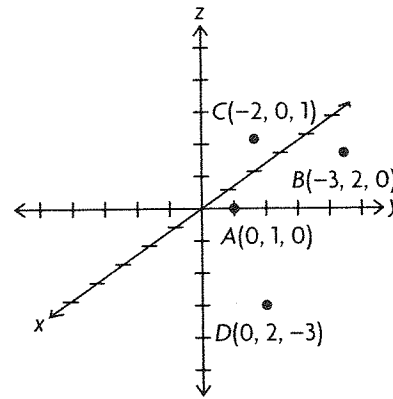

4. a. $(3, -2, 7)$

$$\begin{aligned} l &= \text{magnitude} \\ &= \sqrt{3^2 + (-2)^2 + 7^2} \\ &= \sqrt{9 + 4 + 49} \\ &= \sqrt{62} \\ &\doteq 7.87 \end{aligned}$$

b. $(-9, 3, 14)$

$$\begin{aligned} l &= \text{magnitude} \\ &= \sqrt{(-9)^2 + 3^2 + 14^2} \\ &= \sqrt{81 + 9 + 196} \\ &= \sqrt{286} \\ &\doteq 16.91 \end{aligned}$$

c. (1, 1, 0)

$$\begin{aligned}l &= \text{magnitude} \\ &= \sqrt{1^2 + 1^2 + 0^2} \\ &= \sqrt{2} \\ &\approx 1.41\end{aligned}$$

d. (2, 0, -9)

$$\begin{aligned}l &= \text{magnitude} \\ &= \sqrt{2^2 + 0^2 + (-9)^2} \\ &= \sqrt{4 + 0 + 81} \\ &= \sqrt{85} \\ &\approx 9.22\end{aligned}$$

5. a. $A(x, y, 0)$

In the xy -plane at the point (x, y) .

b. $B(x, 0, z)$

In the xz -plane at the point (x, z) .

c. $C(0, y, z)$

In the yz -plane at the point (y, z) .

6. a. $(-6, 0) + 7(1, -1)$

$$\begin{aligned}&= (-6\vec{i} + 0\vec{j}) + 7(\vec{i} - \vec{j}) \\ &= (-6\vec{i} + 0\vec{j}) + (7\vec{i} - 7\vec{j}) \\ &= \vec{i} - 7\vec{j}\end{aligned}$$

b. $(4, -1, 3) - (-2, 1, 3)$

$$\begin{aligned}&= (4\vec{i} - \vec{j} + 3\vec{k}) - (-2\vec{i} + \vec{j} + 3\vec{k}) \\ &= 6\vec{i} - 2\vec{j}\end{aligned}$$

c. $2(-1, 1, 3) + 3(-2, 3, -1)$

$$\begin{aligned}&= 2(-\vec{i} + \vec{j} + 3\vec{k}) + 3(-2\vec{i} + 3\vec{j} - \vec{k}) \\ &= (-2\vec{i} + 2\vec{j} + 6\vec{k}) + (-6\vec{i} + 9\vec{j} - 3\vec{k}) \\ &= -8\vec{i} + 11\vec{j} + 3\vec{k}\end{aligned}$$

d. $-\frac{1}{2}(4, -6, 8) + \frac{3}{2}(4, -6, 8)$

$$\begin{aligned}&= -\frac{1}{2}(4\vec{i} - 6\vec{j} + 8\vec{k}) + \frac{3}{2}(4\vec{i} - 6\vec{j} + 8\vec{k}) \\ &= (-2\vec{i} + 3\vec{j} - 4\vec{k}) + (6\vec{i} - 9\vec{j} + 12\vec{k}) \\ &= 4\vec{i} - 6\vec{j} + 8\vec{k}\end{aligned}$$

7. a. $\vec{a} + \vec{b}$

$$\begin{aligned}&= (3\vec{i} + 2\vec{j} - \vec{k}) + (-2\vec{i} + \vec{j}) \\ &= \vec{i} + 3\vec{j} - \vec{k}\end{aligned}$$

b. $\vec{a} - \vec{b}$

$$\begin{aligned}&= (3\vec{i} + 2\vec{j} - \vec{k}) - (-2\vec{i} + \vec{j}) \\ &= (3\vec{i} + 2\vec{j} - \vec{k}) + (2\vec{i} - \vec{j}) \\ &= 5\vec{i} + \vec{j} - \vec{k}\end{aligned}$$

c. $2\vec{a} - 3\vec{b}$

$$\begin{aligned}&= 2(3\vec{i} + 2\vec{j} - \vec{k}) - 3(-2\vec{i} + \vec{j}) \\ &= (6\vec{i} + 4\vec{j} - 2\vec{k}) + (6\vec{i} - 3\vec{j}) \\ &= 12\vec{i} + \vec{j} - 2\vec{k}\end{aligned}$$

7.1 Vectors as Forces, pp. 362–364

1. a. 10 N is a melon, 50 N is a chair, 100 N is a computer

b. Answers will vary.

2. a.

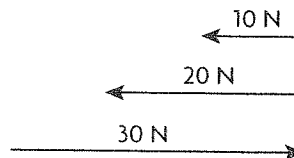

b. 180°

3.

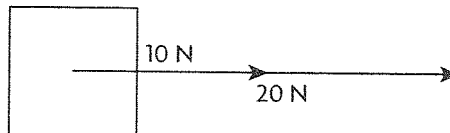

The forces should be placed in a line along the same direction.

4. For three forces to be in equilibrium, they must form a triangle, which is a planar figure.

5.

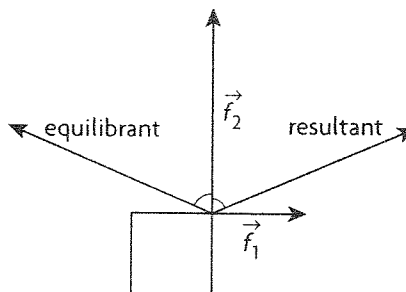

a. The resultant is equivalent in magnitude to the hypotenuse, h , of the triangle with 5 and 12 as sides and is directed northeast at an angle of $\sin^{-1} \frac{12}{h}$.

Thus, the resultant is $\sqrt{5^2 + 12^2} = 13$ N at an angle of $\sin^{-1} \frac{12}{13} = \text{N } 22.6^\circ \text{ E}$. The equilibrant is equal in magnitude and opposite in direction of the resultant. Thus, the equilibrant is 13 N at an angle of $\text{S } 22.6^\circ \text{ W}$.

b. The resultant is $\sqrt{9^2 + 12^2} = 15$ N at an angle of $\sin^{-1} \frac{12}{15} = \text{S } 36.9^\circ \text{ W}$. The equilibrant, then, is 15 N at $\text{N } 36.9^\circ \text{ E}$.

6. For three forces to form equilibrium, they must be able to form a triangle or a balanced line, so

a. Yes, since $3 + 4 > 7$ these can form a triangle.

b. Yes, since $9 + 40 > 41$ these can form a triangle.

c. No, since $\sqrt{5} + 6 < 9$ these cannot form a triangle.

d. Yes, since $9 + 10 = 19$, placing the 9 N and 10 N force in a line directly opposing the 19 N force achieves equilibrium.

7. Arms 90 cm apart will yield a resultant with a smaller magnitude than at 30 cm apart. A resultant with a smaller magnitude means less force to counter your weight, hence a harder chin-up.

8. Using the cosine law, the resultant has a magnitude, r , of

$$r^2 = |\vec{f}_1|^2 + |\vec{f}_2|^2 - 2|\vec{f}_1||\vec{f}_2|\cos 120^\circ$$

$$= 6^2 + 8^2 - 2(6)(8)\left(-\frac{1}{2}\right)$$

$$= 36 + 64 + 48$$

$$= 148$$

$$r = \sqrt{148}$$

$$\doteq 12.17 \text{ N}$$

Using the sine law, the resultant's angle, θ , can be found by

$$\frac{\sin \theta}{8} = \frac{\sin 120^\circ}{12.17}$$

$$\sin \theta = 8 \frac{\frac{\sqrt{3}}{2}}{12.17}$$

$$\theta = \sin^{-1} 8 \frac{\frac{\sqrt{3}}{2}}{12.17}$$

$\doteq 34.7^\circ$ from the 6 N force toward the 8 N force. The equilibrant, then, would be 12.17 N at $180^\circ - 34.7^\circ = 145.3^\circ$ from the 6 N force away from the 8 N force.

9.

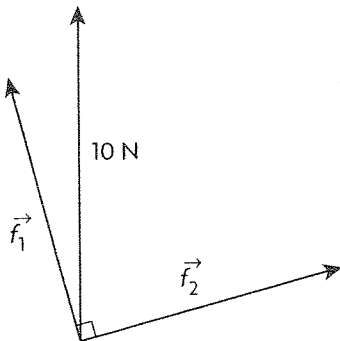

\vec{f}_1 = force 15° from the 10 N force

\vec{f}_2 = force perpendicular to \vec{f}_1

x_1 = component of \vec{f}_1 parallel to the 10 N force

x_2 = component of \vec{f}_2 parallel to the 10 N force

We know that the components of \vec{f}_1 and \vec{f}_2 perpendicular to the 10 N force must be equal, so we can write

$$|\vec{f}_1|\cos 15^\circ = |\vec{f}_2|\cos 75^\circ$$

$$|\vec{f}_1| = |\vec{f}_2| \frac{\cos 75^\circ}{\cos 15^\circ}$$

Now we look at x_1 and x_2 . We know

$$x_1 = |\vec{f}_1|\sin 15^\circ$$

$$x_2 = |\vec{f}_2|\sin 75^\circ$$

$$x_1 + x_2 = 10$$

$$\text{So } |\vec{f}_1|\sin 15^\circ + |\vec{f}_2|\sin 75^\circ = 10$$

Substituting then solving for \vec{f}_2 yields

$$|\vec{f}_2| \frac{\cos 75^\circ}{\cos 15^\circ} \sin 15^\circ + |\vec{f}_2|\sin 75^\circ = 10$$

$$|\vec{f}_2| \left(\frac{\cos 75^\circ}{\cos 15^\circ} \sin 15^\circ + \sin 75^\circ \right) = 10$$

$$|\vec{f}_2|(1.035) = 10$$

$$|\vec{f}_2| = 9.66 \text{ N}$$

Now we solve for \vec{f}_1 :

$$|\vec{f}_1| = |\vec{f}_2| \frac{\cos 75^\circ}{\cos 15^\circ}$$

$$|\vec{f}_1| = (9.66) \frac{\cos 75^\circ}{\cos 15^\circ}$$

$$|\vec{f}_1| = (9.66)(0.268)$$

$$|\vec{f}_1| = 2.59 \text{ N}$$

So the force 15° from the 10 N force is 9.66 N and the force perpendicular to it is 2.59 N.

10. The force of the block is

$(10 \text{ kg})(9.8 \text{ N/kg}) = 98 \text{ N}$. The component of this force parallel to the ramp is

$(98) \sin 30^\circ = (98)\left(\frac{1}{2}\right) = 49 \text{ N}$, directed down the ramp.

So the force preventing this block from moving would be 49 N directed up the ramp.

11. a.

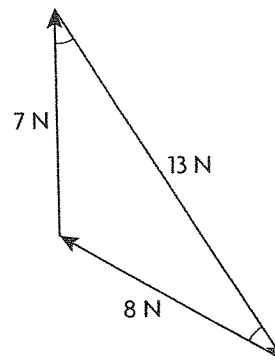

b. Using the cosine law for the angle, θ , we have

$$13^2 = 8^2 + 7^2 - 2(8)(7) \cos \theta$$

$$169 = 64 + 49 - 112 \cos \theta$$

$$56 = -112 \cos \theta$$

$$\cos \theta = \frac{-56}{112}$$

$$\theta = \cos^{-1} \frac{-1}{2}$$

$$= 120$$

This is the angle between the vectors when placed head to tail. So the angle between the vectors when placed tail to tail is $180^\circ - 120^\circ = 60^\circ$.

12. The 10 N force and the 5 N force result in a 5 N force east. The 9 N force and the 14 N force result in a 5 N force south. The resultant of these is now equivalent to the hypotenuse of the right triangle with 5 N as both bases and is directed 45° south of east. So the resultant is $\sqrt{5^2 + 5^2} = \sqrt{50} \approx 7.1$ N 45° south of east.

13.

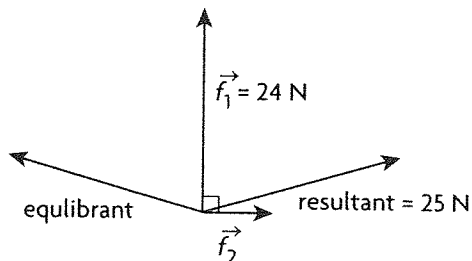

a. Using the Pythagorean theorem,

$$\begin{aligned} |\vec{f}_1|^2 + |\vec{f}_2|^2 &= 25^2 \\ |\vec{f}_2|^2 &= 25^2 - |\vec{f}_1|^2 \\ &= 25^2 - 24^2 \\ &= 49 \\ |\vec{f}_2| &= 7 \end{aligned}$$

b. The angle, θ , between \vec{f}_1 and the resultant is given by

$$\begin{aligned} \sin \theta &= \frac{|\vec{f}_2|}{25} \\ \sin \theta &= \frac{7}{25} \\ \theta &= \sin^{-1} \frac{7}{25} \\ &\approx 16.3^\circ \end{aligned}$$

So the angle between \vec{f}_1 and the equilibrant is $180^\circ - 16.3^\circ = 163.7^\circ$.

14. a.

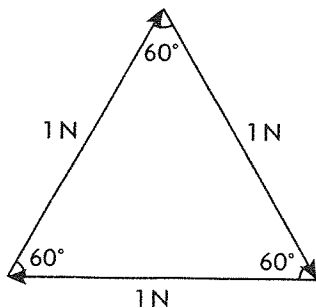

For these three equal forces to be in equilibrium, they must form an equilateral triangle. Since the resultant will lie along one of these lines, and since all angles

of an equilateral triangle are 60° , the resultant will be at a 60° angle with the other two vectors.

b. Since the equilibrant is directed opposite the resultant, the angle between the equilibrant and the other two vectors is $180^\circ - 60^\circ = 120^\circ$.

15. Since \vec{f}_1 and \vec{f}_2 act opposite one another, they net a 10 N force directed west. Since \vec{f}_3 and \vec{f}_4 act opposite one another, they net a 10 N force directed 45° north of east. So using the cosine law to find the resultant, \vec{f}_r ,

$$\begin{aligned} |\vec{f}_r|^2 &= 10^2 + 10^2 - 2(10)(10) \cos 45^\circ \\ &= 200 - 200 \cos 45^\circ \\ &= 200 - 200 \left(\frac{\sqrt{2}}{2} \right) \\ |\vec{f}_r| &= \sqrt{200 - 200 \left(\frac{\sqrt{2}}{2} \right)} \\ &\approx 7.65 \text{ N} \end{aligned}$$

Since our net forces are equal at 10 N, the angle of the resultant is directed halfway between the two, or at $\frac{1}{2}(135^\circ) = 67.5^\circ$ from \vec{f}_2 toward \vec{f}_3 .

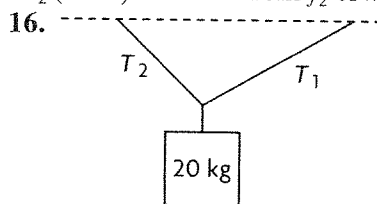

Let T_1 be the tension in the 30° rope and T_2 be the tension in the 45° rope.

Since this system is in equilibrium, we know that the horizontal components of T_1 and T_2 are equal and opposite and the vertical components add to be opposite the action of the mass. Also, the force produced by the mass is $(20 \text{ kg})(9.8 \text{ N/kg}) = 196 \text{ N}$. So we have a system of two equations: the first, $(T_1) \cos 30^\circ = (T_2) \cos 45^\circ$ represents the balance of the horizontal components, and the second, $(T_1) \sin 30^\circ + (T_2) \sin 45^\circ = 196$ represents the balance of the vertical components with the mass. So solving this system of two equations with two variable gives the desired tensions.

$$\begin{aligned} T_1 \cos 30^\circ &= T_2 \cos 45^\circ \\ T_1 &= T_2 \frac{\cos 45^\circ}{\cos 30^\circ} \end{aligned}$$

$$T_1 \sin 30^\circ + T_2 \sin 45^\circ = 196$$

$$\left(T_2 \frac{\cos 45^\circ}{\cos 30^\circ} \right) \sin 30^\circ + T_2 \sin 45^\circ = 196$$

$$T_2 \left(\left(\frac{\cos 45^\circ}{\cos 30^\circ} \right) \sin 30^\circ + \sin 45^\circ \right) = 196$$

$$\begin{aligned}
 T_2(1.12) &= 196 \\
 T_2 &\doteq 175.73 \text{ N} \\
 T_1 &= (175.73) \frac{\cos 45^\circ}{\cos 30^\circ} \\
 &\doteq 143.48 \text{ N}
 \end{aligned}$$

Thus the tension in the 45° rope is 175.73 N and the tension in the 30° rope is 143.48 N.

17.

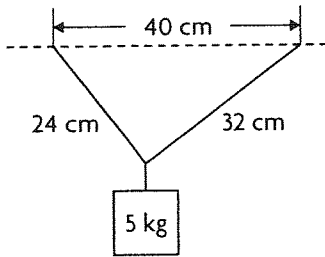

First, use the Cosine Law to find the angles the strings make at the point of suspension. Let θ_1 be the angle made by the 32 cm string and θ_2 be the angle made by the 24 cm string.

$$\begin{aligned}
 24^2 &= 32^2 + 40^2 - 2(32)(40)\cos \theta_1 \\
 -2048 &= -2560 \cos \theta_1 \\
 \theta_1 &= \cos^{-1} \frac{2048}{2560} \\
 &\doteq 36.9^\circ \\
 32^2 &= 24^2 + 40^2 - 2(24)(40)\cos \theta_2 \\
 -1152 &= -1920 \cos \theta_2 \\
 \theta_2 &= \cos^{-1} \frac{1152}{1920} \\
 &\doteq 53.1^\circ
 \end{aligned}$$

A keen eye could have recognized this triangle as a 3-4-5 right triangle and simply used the Pythagorean theorem as well. Now we set up the same system of equations as in problem 16, with T_1 being the tension in the 32 cm string and T_2 being the tension in the 24 cm string, and the force of the mass being $(5 \text{ kg})(9.8 \text{ N/kg}) = 49 \text{ N}$.

$$\begin{aligned}
 T_1 \cos 36.9^\circ &= T_2 \cos 53.1^\circ \\
 T_1 &= T_2 \frac{\cos 53.1^\circ}{\cos 36.9^\circ} \\
 T_1 \sin 36.9^\circ + T_2 \sin 53.1^\circ &= 49 \\
 \left(T_2 \frac{\cos 53.1^\circ}{\cos 36.9^\circ} \right) \sin 36.9^\circ + T_2 \sin 53.1^\circ &= 49 \\
 T_2 \left(\left(\frac{\cos 53.1^\circ}{\cos 36.9^\circ} \right) \sin 36.9^\circ + \sin 53.1^\circ \right) &= 49 \\
 T_2(1.25) &= 49 \\
 T_2 &\doteq 39.2 \text{ N} \\
 T_1 &= (39.2) \frac{\cos 53.1^\circ}{\cos 36.9^\circ} \\
 &\doteq 29.4 \text{ N}
 \end{aligned}$$

Thus the tension in the 24 cm string is 39.2 N and the tension in the 32 cm string is 29.4 N.

18.

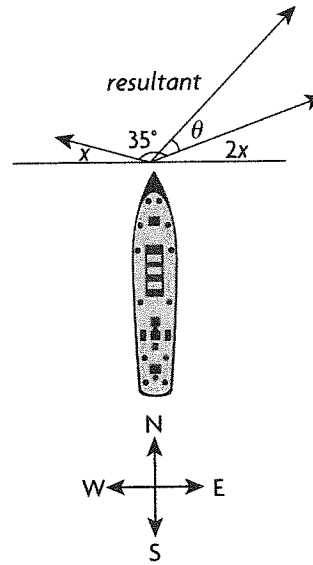

(Port means left and starboard means right.) We are looking for the resultant of these two force vectors that are 35° apart. We don't know the exact value of the force, so we will call it x . So the small tug is pulling with a force of x and the large tug is pulling with a force of $2x$. To find the magnitude of the resultant, r , in terms of x , we use the cosine law.

$$\begin{aligned}
 r^2 &= x^2 + (2x)^2 - 2(x)(2x)\cos 145^\circ \\
 &= x^2 + 4x^2 - 4x^2 \cos 145^\circ \\
 &\doteq 5x^2 - 4x^2(-0.8192) \\
 &\doteq 5x^2 + 3.2768x^2 \\
 &\doteq 8.2768x^2 \\
 r &\doteq \sqrt{8.2768x^2} \\
 &\doteq 2.8769x
 \end{aligned}$$

Now we use the cosine law again to find the angle, θ , made by the resultant.

$$\begin{aligned}
 x^2 &= r^2 + (2x)^2 - 2(2.8769x)(2x)\cos \theta \\
 x^2 &= 8.2768x^2 + 4x^2 - 11.5076x^2 \cos \theta \\
 x^2 &= 12.2768x^2 - 11.5076x^2 \cos \theta \\
 -11.2768x^2 &= -11.5076x^2 \cos \theta \\
 \cos \theta &= \frac{11.2768}{11.5076} \\
 \theta &= \cos^{-1} \left(\frac{11.2768}{11.5076} \right)
 \end{aligned}$$

$\doteq 11.5^\circ$ from the large tug toward the small tug, for a net of 8.5° to the starboard side.

19.

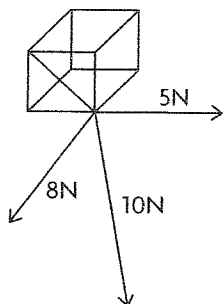

a. First we will find the resultant of the 5 N and 8 N forces. Use the Pythagorean theorem to find the magnitude, m .

$$\begin{aligned} m^2 &= 5^2 + 8^2 \\ &= 25 + 64 \\ &= 89 \end{aligned}$$

$$m = \sqrt{89} \doteq 9.4$$

Next we use the Pythagorean theorem again to find the magnitude, M , of the resultant of this net force and the 10 N force.

$$\begin{aligned} M^2 &= m^2 + 10^2 \\ &= 89 + 100 \\ &= 189 \end{aligned}$$

$$M = \sqrt{189} \doteq 13.75$$

Since the equilibrant is equal in magnitude to the resultant, we have the magnitude of the equilibrant equal to approximately 13.75 N.

b. To find each angle, use the definition of cosine with respect each force as a leg and the resultant as the hypotenuse. Let θ_{5N} be the angle from the 5 N force to the resultant, θ_{8N} be the angle from the 8 N force to the resultant, and θ_{10N} be the angle from the 10 N force to the resultant.

Let the sign of the resultant be negative, since it is in a direction away from the head of each of the given forces.

$$\cos \theta_{5N} = \frac{5}{-13.75}$$

$$\theta_{5N} = \cos^{-1} \left(\frac{5}{-13.75} \right)$$

$$\doteq 111.3^\circ$$

$$\cos \theta_{8N} = \frac{8}{-13.75}$$

$$\theta_{8N} = \cos^{-1} \left(\frac{8}{-13.75} \right)$$

$$\doteq 125.6^\circ$$

$$\cos \theta_{10N} = \frac{10}{-13.75}$$

$$\theta_{10N} = \cos^{-1} \left(\frac{10}{-13.75} \right)$$

$$\doteq 136.7^\circ$$

20. We know that the resultant of these two forces is equal in magnitude and angle to the diagonal line of the parallelogram formed with \vec{f}_1 and \vec{f}_2 as legs and has diagonal length $|\vec{f}_1 + \vec{f}_2|$. We also know from the cosine law that

$$|\vec{f}_1 + \vec{f}_2|^2 = |\vec{f}_1|^2 + |\vec{f}_2|^2 - 2|\vec{f}_1||\vec{f}_2|\cos \phi$$

where ϕ is the supplement to θ in our parallelogram.

Since we know $\phi = 180 - \theta$, then

$$\cos \phi = \cos(180 - \theta) = -\cos \theta.$$

Thus we have

$$\begin{aligned} |\vec{f}_1 + \vec{f}_2|^2 &= |\vec{f}_1|^2 + |\vec{f}_2|^2 - 2|\vec{f}_1||\vec{f}_2|\cos \phi \\ &= |\vec{f}_1|^2 + |\vec{f}_2|^2 + 2|\vec{f}_1||\vec{f}_2|\cos \theta \end{aligned}$$

$$|\vec{f}_1 + \vec{f}_2| = \sqrt{|\vec{f}_1|^2 + |\vec{f}_2|^2 + 2|\vec{f}_1||\vec{f}_2|\cos \theta}$$

7.2 Velocity, pp. 367–370

1. a. Both the woman and the train's velocities are in the same direction, so we add them.

$$80 \text{ km/h} + 4 \text{ km/h} = 84 \text{ km/h}$$

b. The woman's velocity is directed opposite that of train, so we subtract her velocity from the train's.

$$80 \text{ km/h} - 4 \text{ km/h} = 76 \text{ km/h. The resultant is in the same direction as the train's movement.}$$

2. a. The velocity of the wind is directed opposite that of the airplane, so we subtract the wind's velocity from the airplane's.

$$600 \text{ km/h} - 100 \text{ km/h} = 500 \text{ km/h north.}$$

b. Both the wind and the airplane's velocities are in the same direction, so we add them.

$$600 \text{ km/h} + 100 \text{ km/h} = 700 \text{ km/h north.}$$

3. We use the Pythagorean theorem to find the magnitude, m , of the resultant velocity and we use the definition of sine to find the angle, θ , made.

$$\begin{aligned} m^2 &= 300^2 + 50^2 \\ &= 90\,000 + 2\,500 \\ &= 92\,500 \end{aligned}$$

$$\begin{aligned} m &= \sqrt{92\,500} \\ &\doteq 304.14 \text{ km/h} \end{aligned}$$

$$\tan \theta = \frac{50}{300}$$

$$\theta = \tan^{-1} \frac{50}{300}$$

$$\doteq 9.5^\circ. \text{ The resultant is } 304.14 \text{ km/h, W } 9.5^\circ \text{ S.}$$

4. Adam must swim at an angle, θ , upstream so as to counter the 1 km/h velocity of the stream. This is equivalent to Adam swimming along the hypotenuse of a right triangle with 1 km/h leg and a 2 km/h hypotenuse. So the angle is found using the definition of cosine.

$$\cos \theta = \frac{1}{2}$$

$$\theta = \cos^{-1} \frac{1}{2}$$

$$= 60^\circ \text{ upstream}$$

5. a. 2 m/s forward

b. $20 \text{ m/s} + 2 \text{ m/s} = 22 \text{ m/s}$ in the direction of the car

6. Since the two velocities are at right angles we can use the Pythagorean theorem to find the magnitude, m , of the resultant velocity and we use the definition of sine to find the angle, θ , made.

$$\begin{aligned} m^2 &= 12^2 + 5^2 \\ &= 144 + 25 \\ &= 169 \end{aligned}$$

$$\begin{aligned} m &= \sqrt{169} \\ &= 13 \text{ m/s} \end{aligned}$$

$$\sin \theta = \frac{5}{13}$$

$$\theta = \sin^{-1} \frac{5}{13}$$

$\doteq 22.6^\circ$ from the direction of the boat toward the direction of the current. This results in a net of $22.6^\circ + 15^\circ = 37.6^\circ$, or N 37.6° W.

7. a. First we find the components of the resultant directed north and directed west. The component directed north is the velocity of the airplane, 800, minus $100 \sin 45^\circ$, since the wind forms a 45° angle south of west. The western component of the resultant is simply $100 \cos 45^\circ$. So we use the Pythagorean theorem to find the magnitude, m , of the resultant and the definition of sine to find the angle, θ , of the resultant.

$$\begin{aligned} m^2 &= (800 - 100 \sin 45^\circ)^2 + (100 \cos 45^\circ)^2 \\ &\doteq (729.29)^2 + (71.71)^2 \\ &\doteq 536\,863.8082 \end{aligned}$$

$$m \doteq 732.71 \text{ km/h}$$

Use the sine law to determine the direction.

$$\frac{\sin \theta}{100} = \frac{\sin 45^\circ}{732.71}$$

$$\theta \doteq 5.5^\circ$$

The direction is N 5.5° W.

b. The airplane is travelling at approximately 732.71 km/h, so in 1 hour the airplane will travel about 732.71 km.

8. a. First we find the velocity of the airplane. We use the Pythagorean theorem to find the magnitude, m , of the resultant.

$$\begin{aligned} m^2 &= 450^2 + 100^2 \\ &= 202\,500 + 10\,000 \\ &= 212\,500 \\ m &= \sqrt{212\,500} \\ &\doteq 461 \text{ km/h} \end{aligned}$$

So in 3 hours, the airplane will travel about $(461 \text{ km/h})(3 \text{ h}) = 1383 \text{ km}$.

b. To find the angle, θ , the airplane travels, we use the definition of sine.

$$\sin \theta = \frac{100}{461}$$

$$\theta = \sin^{-1} \frac{100}{461}$$

$$\doteq 12.5^\circ \text{ east of north.}$$

9. a. To find the angle, θ , at which to fly is the equivalent of the angle of a right triangle with 44 as the opposite leg and 244 as the hypotenuse. So we use the definition of sine to find this angle.

$$\sin \theta = \frac{44}{244}$$

$$\theta = \sin^{-1} \frac{44}{244}$$

$$\doteq 10.4^\circ \text{ south of west.}$$

b. By the Pythagorean Theorem, the resultant ground speed of the airplane is $\sqrt{(244^2 - 44^2)} = 240 \text{ km/h}$. Since time = distance/rate, the duration of the flight is simply $(480 \text{ km}) / (240 \text{ km/h}) = 2 \text{ h}$.

10. a. Since Judy is swimming perpendicular to the flow of the river, her resultant velocity is simply the hypotenuse of a right triangle with 3 and 4 as bases, which is a 3-4-5 right triangle. Thus, Judy's resultant velocity is 5 km/h. The direction is determined by $\tan \theta = \frac{4}{3}$. $\theta \doteq 53.1^\circ$ downstream
b. Judy's distance traveled down the river would be the "4" leg of the 3-4-5 triangle formed by the vectors, but scaled down so that 1m (the width of the river) is equivalent to the "3" leg. So her distance traveled is $\frac{4}{3} \doteq 1.33 \text{ km}$. This makes her about 0.67 km from Helen's cottage.

c. While in the river, Judy is swimming at 5 km/h for a distance of $\frac{5}{3} \text{ km}$. Since time = distance/rate, her time taken is

$$\frac{\frac{5}{3} \text{ km}}{5 \text{ km/h}} = \frac{1}{3} \text{ hours} = 20 \text{ minutes.}$$

11.

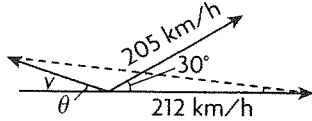

a. and b. Here, 205 km/h directed 30° north of east is the resultant of 212 km/h directed east, and the wind speed, v , directed at some angle. This problem is more easily approached finding the wind speed, v , first. So we will do that using the cosine law.

$$\begin{aligned} v^2 &= 205^2 + 212^2 - 2(205)(212)\cos 30^\circ \\ &= 42\,025 + 44\,944 - 86\,920 \cos 30^\circ \\ &= 86\,969 - 75\,275 \\ &= 11\,694 \\ v &= \sqrt{11\,694} \\ &\doteq 108 \text{ km/h} \end{aligned}$$

Now to find the wind's direction, we simply find the angle supplementary to the lesser angle, θ , formed by the parallelogram of these three velocities. We can use the sine law for this.

$$\begin{aligned} \frac{\sin \theta}{205} &= \frac{\sin 30^\circ}{108} \\ \sin \theta &= 205 \left(\frac{\sin 30^\circ}{108} \right) \\ \theta &= \sin^{-1} \left(205 \left(\frac{\sin 30^\circ}{108} \right) \right) \\ &\doteq 71.6^\circ \end{aligned}$$

Thus, the direction of v is the angle supplementary to θ in the parallelogram:

$$180^\circ - 71.6^\circ = 108.4^\circ = 18.4^\circ \text{ west of north.}$$

12.

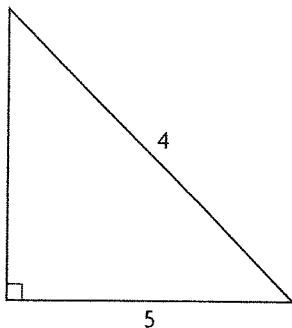

Since her swimming speed is a maximum of 4 km/h, this is her maximum resultant magnitude, which is also the hypotenuse of the triangle formed by her and the river's velocity vector. Since one of these legs is 5 km/h, we have a triangle with a leg larger than its hypotenuse, which is impossible.

13. a. First we need to find Mary's resultant velocity, v . Since this resultant is the diagonal of the parallelogram formed by hers and the river's velocity, we can use the cosine law with the angle, θ , of the parallelogram adjacent 30° .

$$\begin{aligned} v^2 &= 3^2 + 4^2 - 2(3)(4)\cos 150^\circ \\ &= 9 + 16 - 24 \cos 150^\circ \\ &= 25 + 20.8 \\ &= 45.8 \\ v &= \sqrt{45.8} \\ &\doteq 6.8 \text{ m/s} \end{aligned}$$

So in 10 seconds, Mary travels about $(6.8 \text{ m/s})(10 \text{ s}) = 68 \text{ m}$.

b. Since Mary is travelling at 3 m/s at an angle of 30° , to find the component of her velocity, v , perpendicular to the current, we use the definition of sine.

$$\begin{aligned} v &= 3 \sin 30^\circ \\ &= 3 \left(\frac{1}{2} \right) \\ &= 1.5 \text{ m/s perpendicular to the current.} \end{aligned}$$

So since time = distance/rate, the time taken is $(150 \text{ m})/(1.5 \text{ m/s}) = 100 \text{ s}$.

14. a. So we have a 5.5 m/s vector and a 4 m/s vector with a resultant vector that is directed 45° south of west. Letting θ be the angle between the 4 km/h vector and the resultant, we can construct a parallelogram using these three vectors and a subsequent triangle with θ opposite the 5.5 m/s vector and 45° opposite the 4 m/s vector. We now use the sine law to find θ .

$$\begin{aligned} \frac{\sin \theta}{5.5} &= \frac{\sin 45^\circ}{4} \\ \sin \theta &= 5.5 \left(\frac{\sin 45^\circ}{4} \right) \\ \theta &= \sin^{-1} \left(5.5 \left(\frac{\sin 45^\circ}{4} \right) \right) \\ &\doteq 76.5^\circ \text{ from the resultant.} \end{aligned}$$

Since the resultant is 45° west of south, Dave's direction is $76.5^\circ + 45^\circ = 121.5^\circ$ west of south, which is equivalent to about $180^\circ - 121.5^\circ = 58.5^\circ$ upstream.

b. First, we find the magnitude, m , of Dave's 4 m/s velocity in the direction perpendicular to the river. This is done using the definition of sine.

$$\begin{aligned} m &= 4 \sin 58.5^\circ \\ &\doteq 3.41 \text{ m/s perpendicular to the river.} \end{aligned}$$

Since time is distance/rate, we have $(200 \text{ m})/(3.41 \text{ m/s}) \doteq 58.6 \text{ s}$.

15. Let b represent the speed of the steamboat and c represent the speed of the current. On the way downstream, the effective speed is $b + c$, and upstream is $b - c$. The distance upstream and downstream is the same, so $5(b + c) = 7(b - c)$. So, $b = 6c$. This means that the speed of the boat is 6 times the speed of the current. So, $(6c + c) \cdot 5$

or 35c is the distance. This means that it would take a raft 35 hours moving with the speed of the current to get from A to B.

7.3 The Dot Product of Two Geometric Vectors, pp. 377–378

1. $\vec{a} \cdot \vec{b} = |\vec{a}||\vec{b}|\cos \theta = 0$. This means $|\vec{a}| = 0$, or $|\vec{b}| = 0$, or $\cos \theta = 0$. To be guaranteed that the two vectors are perpendicular, the vectors must be nonzero.

2. $\vec{a} \cdot \vec{b}$ is a scalar, and a dot product is only defined for vectors, so $(\vec{a} \cdot \vec{b}) \cdot \vec{c}$ is meaningless.

3. Answers may vary. Let $\vec{a} = \vec{i}$, $\vec{b} = \vec{j}$, $\vec{c} = -\vec{i}$.
 $\vec{a} \cdot \vec{b} = 0$, $\vec{b} \cdot \vec{c} = 0$, but $\vec{a} \cdot \vec{c} = -1$.

4. $\vec{a} \cdot \vec{b} = \vec{b} \cdot \vec{a} = \vec{b} \cdot \vec{c}$ because $\vec{c} = \vec{a}$

5. Since \vec{a} and \vec{b} are unit vectors, $|\vec{a}| = |\vec{b}| = 1$ and since they are pointing in opposite directions then $\theta = 180^\circ$ so $\cos \theta = -1$. Therefore $\vec{a} \cdot \vec{b} = -1$.

$$\begin{aligned} 6. \text{ a. } \vec{p} \cdot \vec{q} &= |\vec{p}||\vec{q}|\cos \theta \\ &= (4)(8)\cos(60^\circ) \\ &= (32)(.5) \\ &= 16 \end{aligned}$$

$$\begin{aligned} \text{ b. } \vec{x} \cdot \vec{y} &= |\vec{x}||\vec{y}|\cos \theta \\ &= (2)(4)\cos(150^\circ) \\ &= (8)\left(-\frac{\sqrt{3}}{2}\right) \\ &\doteq -6.93 \end{aligned}$$

$$\begin{aligned} \text{ c. } \vec{a} \cdot \vec{b} &= |\vec{a}||\vec{b}|\cos \theta \\ &= (0)(8)\cos(100^\circ) \\ &= 0 \end{aligned}$$

$$\begin{aligned} \text{ d. } \vec{p} \cdot \vec{q} &= |\vec{p}||\vec{q}|\cos \theta \\ &= (1)(1)\cos(180^\circ) \\ &= (1)(-1) \\ &= -1 \end{aligned}$$

$$\begin{aligned} \text{ e. } \vec{m} \cdot \vec{n} &= |\vec{m}||\vec{n}|\cos \theta \\ &= (2)(5)\cos(90^\circ) \\ &= (10)(0) \\ &= 0 \end{aligned}$$

$$\begin{aligned} \text{ f. } \vec{u} \cdot \vec{v} &= |\vec{u}||\vec{v}|\cos \theta \\ &= (4)(8)\cos 145^\circ \\ &\doteq -26.2 \end{aligned}$$

$$\begin{aligned} 7. \text{ a. } \vec{x} \cdot \vec{y} &= |\vec{x}||\vec{y}|\cos \theta \\ 12\sqrt{3} &= (8)(3)\cos \theta \\ \frac{\sqrt{3}}{2} &= \cos \theta \\ \theta &= 30^\circ \end{aligned}$$

$$\begin{aligned} \text{ b. } \vec{m} \cdot \vec{n} &= |\vec{m}||\vec{n}|\cos \theta \\ (6) &= (6)(6)\cos \theta \\ \frac{1}{6} &= \cos \theta \end{aligned}$$

$$\theta \doteq 80^\circ$$

$$\begin{aligned} \text{ c. } \vec{p} \cdot \vec{q} &= |\vec{p}||\vec{q}|\cos \theta \\ 3 &= (5)(1)\cos \theta \\ \frac{3}{5} &= \cos \theta \end{aligned}$$

$$\theta \doteq 53^\circ$$

$$\begin{aligned} \text{ d. } \vec{p} \cdot \vec{q} &= |\vec{p}||\vec{q}|\cos \theta \\ -3 &= (5)(1)\cos \theta \\ -\frac{3}{5} &= \cos \theta \end{aligned}$$

$$\theta \doteq 127^\circ$$

$$\begin{aligned} \text{ e. } \vec{a} \cdot \vec{b} &= |\vec{a}||\vec{b}|\cos \theta \\ 10.5 &= (7)(3)\cos \theta \\ \frac{1}{2} &= \cos \theta \end{aligned}$$

$$\theta = 60^\circ$$

$$\begin{aligned} \text{ f. } \vec{u} \cdot \vec{v} &= |\vec{u}||\vec{v}|\cos \theta \\ -50 &= (10)(10)\cos \theta \\ -\frac{1}{2} &= \cos \theta \end{aligned}$$

$$\theta = 120^\circ$$

$$\begin{aligned} 8. \vec{a} \cdot \vec{b} &= |\vec{a}||\vec{b}|\cos \theta \\ &= (7.5)(6)\cos(180^\circ - 120^\circ) \\ &= (45)\left(\frac{1}{2}\right) \\ &= 22.5 \end{aligned}$$

Note: θ is the angle between the two vectors when they are tail to tail, so $\theta \neq 120^\circ$.

$$\begin{aligned} 9. \text{ a. } (\vec{a} + 5\vec{b}) \cdot (2\vec{a} - 3\vec{b}) &= \vec{a} \cdot 2\vec{a} - \vec{a} \cdot 3\vec{b} \\ &\quad + 5\vec{b} \cdot 2\vec{a} - 5\vec{b} \cdot 3\vec{b} \\ &= 2|\vec{a}|^2 - 15|\vec{b}|^2 \\ &\quad - 3\vec{a} \cdot \vec{b} + 10\vec{a} \cdot \vec{b} \\ &= 2|\vec{a}|^2 - 15|\vec{b}|^2 \\ &\quad + 7\vec{a} \cdot \vec{b} \end{aligned}$$

$$\begin{aligned} \text{ b. } 3\vec{x} \cdot (\vec{x} - 3\vec{y}) - (\vec{x} - 3\vec{y}) \cdot (-3\vec{x} + \vec{y}) \\ &= 3|\vec{x}|^2 - 3\vec{x} \cdot 3\vec{y} + 3|\vec{x}|^2 - \vec{x} \cdot \vec{y} - (-3\vec{y} \cdot -3\vec{x}) \\ &\quad + 3|\vec{y}|^2 \\ &= 6|\vec{x}|^2 - 9\vec{x} \cdot \vec{y} - \vec{x} \cdot \vec{y} - 9\vec{x} \cdot \vec{y} + 3|\vec{y}|^2 \\ &= 6|\vec{x}|^2 - 19\vec{x} \cdot \vec{y} + 3|\vec{y}|^2 \end{aligned}$$

10. $|\vec{0}| = 0$ so the dot product of any vector with $\vec{0}$ is 0.

$$11. (\vec{a} - 5\vec{b}) \cdot (\vec{a} - \vec{b}) = |\vec{a} - 5\vec{b}| |\vec{a} - \vec{b}| \cos(90^\circ)$$

$$|\vec{a}|^2 - \vec{a} \cdot \vec{b} - 5\vec{b} \cdot \vec{a} + 5|\vec{b}|^2 = 0$$

$$|\vec{a}|^2 + 5|\vec{b}|^2 = 6\vec{a} \cdot \vec{b}$$

$$\vec{a} \cdot \vec{b} = \frac{1}{6}(|\vec{a}|^2 + 5|\vec{b}|^2)$$

$$= 1$$

$$12. \text{ a. } (\vec{a} + \vec{b}) \cdot (\vec{a} + \vec{b}) = \vec{a} \cdot \vec{a} + \vec{a} \cdot \vec{b} + \vec{b} \cdot \vec{a} + \vec{b} \cdot \vec{b}$$

$$= |\vec{a}|^2 + \vec{a} \cdot \vec{b} + \vec{a} \cdot \vec{b} + |\vec{b}|^2$$

$$= |\vec{a}|^2 + 2\vec{a} \cdot \vec{b} + |\vec{b}|^2$$

$$\text{ b. } (\vec{a} + \vec{b}) \cdot (\vec{a} - \vec{b}) = \vec{a} \cdot \vec{a} - \vec{a} \cdot \vec{b} + \vec{b} \cdot \vec{a} - \vec{b} \cdot \vec{b}$$

$$= |\vec{a}|^2 - \vec{a} \cdot \vec{b} + \vec{a} \cdot \vec{b} - |\vec{b}|^2$$

$$= |\vec{a}|^2 - |\vec{b}|^2$$

$$13. \text{ a. } |\vec{a}|^2 = \vec{a} \cdot \vec{a}$$

$$= (\vec{b} + \vec{c}) \cdot (\vec{b} + \vec{c})$$

$$= |\vec{b}|^2 + 2\vec{b} \cdot \vec{c} + |\vec{c}|^2$$

$$\text{ b. } \vec{b} \cdot \vec{c} = |\vec{b}| |\vec{c}| \cos(90^\circ) = 0$$

$$\text{ Therefore } |\vec{a}|^2 = |\vec{b}|^2 + |\vec{c}|^2.$$

This is just what the Pythagorean theorem says, where \vec{b} and \vec{c} are the legs of the right triangle.

$$14. (\vec{u} + \vec{v} + \vec{w}) \cdot (\vec{u} + \vec{v} + \vec{w})$$

$$= \vec{u} \cdot \vec{u} + \vec{u} \cdot \vec{v} + \vec{u} \cdot \vec{w} + \vec{v} \cdot \vec{u} + \vec{v} \cdot \vec{v}$$

$$+ \vec{v} \cdot \vec{w} + \vec{w} \cdot \vec{u} + \vec{w} \cdot \vec{v} + \vec{w} \cdot \vec{w}$$

$$= |\vec{u}|^2 + |\vec{v}|^2 + |\vec{w}|^2 + 2|\vec{u}||\vec{v}|\cos(90^\circ)$$

$$+ 2|\vec{u}||\vec{w}|\cos(90^\circ) + 2|\vec{v}||\vec{w}|\cos(90^\circ)$$

$$= (1)^2 + (2)^2 + (3)^2$$

$$= 14$$

$$15. |\vec{u} + \vec{v}|^2 + |\vec{u} - \vec{v}|^2$$

$$= (\vec{u} + \vec{v}) \cdot (\vec{u} + \vec{v}) + (\vec{u} - \vec{v}) \cdot (\vec{u} - \vec{v})$$

$$= |\vec{u}|^2 + 2\vec{u} \cdot \vec{v} + |\vec{v}|^2 + |\vec{u}|^2 - 2\vec{u} \cdot \vec{v} + |\vec{v}|^2$$

$$= 2|\vec{u}|^2 + 2|\vec{v}|^2$$

$$16. (\vec{a} + \vec{b}) \cdot (\vec{a} + \vec{b} + \vec{c})$$

$$= |\vec{a}|^2 + \vec{a} \cdot \vec{b} + \vec{a} \cdot \vec{c} + \vec{b} \cdot \vec{a} + |\vec{b}|^2 + \vec{b} \cdot \vec{c}$$

$$= 1 + 2|\vec{a}||\vec{b}|\cos(60^\circ) + |\vec{a}||\vec{c}|\cos(60^\circ) + 1$$

$$+ |\vec{b}||\vec{c}|\cos(120^\circ)$$

$$= 2 + 2\left(\frac{1}{2}\right) + \frac{1}{2} - \frac{1}{2}$$

$$= 3$$

$$17. \vec{a} + \vec{b} + \vec{c} = \vec{0}$$

$$\vec{a} \cdot (\vec{a} + \vec{b} + \vec{c}) + \vec{b} \cdot (\vec{a} + \vec{b} + \vec{c})$$

$$+ \vec{c} \cdot (\vec{a} + \vec{b} + \vec{c}) = 0$$

$$|\vec{a}|^2 + \vec{a} \cdot \vec{b} + \vec{a} \cdot \vec{c} + \vec{b} \cdot \vec{a} + |\vec{b}|^2 + \vec{b} \cdot \vec{c}$$

$$+ \vec{c} \cdot \vec{a} + \vec{c} \cdot \vec{b} + |\vec{c}|^2 = 0$$

$$1 + 4 + 9 + 2(\vec{a} \cdot \vec{b} + \vec{a} \cdot \vec{c} + \vec{b} \cdot \vec{c}) = 0$$

$$2(\vec{a} \cdot \vec{b} + \vec{a} \cdot \vec{c} + \vec{b} \cdot \vec{c}) = -14$$

$$\vec{a} \cdot \vec{b} + \vec{a} \cdot \vec{c} + \vec{b} \cdot \vec{c} = -7$$

$$18. \vec{d} = \vec{b} - \vec{c}$$

$$\vec{b} = \vec{d} + \vec{c}$$

$$\vec{c} \cdot \vec{a} = ((\vec{b} \cdot \vec{a})\vec{a}) \cdot \vec{a}$$

$$\vec{c} \cdot \vec{a} = (\vec{b} \cdot \vec{a})(\vec{a} \cdot \vec{a}) \text{ because } \vec{b} \cdot \vec{a} \text{ is a scalar}$$

$$\vec{c} \cdot \vec{a} = (\vec{b} \cdot \vec{a})|\vec{a}|^2$$

$$\vec{c} \cdot \vec{a} = (\vec{d} + \vec{c}) \cdot \vec{a} \text{ because } |\vec{a}| = 1$$

$$\vec{c} \cdot \vec{a} = \vec{d} \cdot \vec{a} + \vec{c} \cdot \vec{a}$$

$$\vec{d} \cdot \vec{a} = 0$$

7.4 The Dot Product for Algebraic Vectors, pp. 385–387

$$1. \vec{a} \cdot \vec{b} = 0$$

$$(-1)b_1 + b_2 = 0$$

$$b_2 = b_1$$

Any vector of the form (c, c) is perpendicular to \vec{a} . Therefore there are infinitely many vectors perpendicular to \vec{a} . Answers may vary. For example: $(1, 1), (2, 2), (3, 3)$.

$$2. \text{ a. } \vec{a} \cdot \vec{b} = (-2)(1) + (1)(2)$$

$$= 0$$

$$\theta = 90^\circ$$

$$\text{ b. } \vec{a} \cdot \vec{b} = (2)(4) + (3)(3) + (-1)(-17)$$

$$= 8 + 9 + 17$$

$$= 34 > 0$$

$$\cos \theta > 0$$

θ is acute

$$\text{ c. } \vec{a} \cdot \vec{b} = (1)(3) + (-2)(-2) + (5)(-2)$$

$$= 3 + 4 - 10$$

$$= -3 < 0$$

$$\cos \theta < 0$$

θ is obtuse

3. Any vector in the xy -plane is of the form $\vec{a} = (a_1, a_2, 0)$. Let $\vec{b} = (0, 0, 1)$.

$$\vec{a} \cdot \vec{b} = (0)(a_1) + (0)(a_2) + (0)(1)$$

$$= 0$$

Therefore $(0, 0, 1)$ is perpendicular to every vector in the xy -plane.

Any vector in the xz -plane is of the form $\vec{c} = (c_1, 0, c_3)$. Let $\vec{d} = (0, 1, 0)$.

$$\vec{c} \cdot \vec{d} = (0)(c_1) + (0)(1) + (0)(c_3)$$

$$= 0$$

Therefore $(0, 1, 0)$ is perpendicular to every vector in the xz -plane.

Any vector in the yz -plane is of the form $\vec{z} = (0, e_2, e_3)$. Let $\vec{f} = (1, 0, 0)$.

$$\vec{z} \cdot \vec{f} = (1)(0) + (0)(e_2) + (0)(e_3) = 0$$

Therefore $(1, 0, 0)$ is perpendicular to every vector in the yz -plane.

$$4. \text{ a. } (1, 2, -1) \cdot (4, 3, 10) = 4 + 6 - 10 = 0$$

$$(-4, -5, -6) \cdot \left(5, -3, -\frac{5}{6}\right) = -20 + 15 + 5 = 0$$

b. If any of the vectors were collinear then one would be a scalar multiple of the other. Comparing the signs of the individual components of each vector eliminates $(1, 2, -1)$ and $(5, -3, -\frac{5}{6})$. All of the components of $(-4, -5, -6)$ have the same sign and the same is true for $(4, 3, 10)$, but $(4, 3, 10)$ is not a scalar multiple of $(-4, -5, -6)$. Therefore none of the vectors are collinear.

5. a. Using the strategy of Example 5 yields $(x, y) \cdot (1, -2) = 0$ and $(x, y) \cdot (1, 1) = 0$
 $x - 2y = 0$ and $x + y = 0$
 $3y = 0$

Therefore the only result is $x = y = 0$, or $(0, 0)$.

This is because $(1, -2)$ and $(1, 1)$ both lie on the xy -plane and are not collinear, so any vector that is perpendicular to both vectors must be in R^3 which does not exist in R^2 .

b. If we select any two vectors that are not collinear in R^2 , then any vector that is perpendicular to both cannot be in R^2 and must be in R^3 . This is not possible since R^3 does not exist in R^2 .

$$6. \text{ a. } \cos \theta = \frac{\vec{a} \cdot \vec{b}}{|\vec{a}| |\vec{b}|} = \frac{(5)(-1) + (3)(-2)}{\sqrt{25 + 9} \sqrt{1 + 4}} = \frac{-11}{\sqrt{(34)(5)}} = \frac{-11}{\sqrt{170}}$$

$$\theta \doteq 148^\circ$$

$$\text{b. } \cos \theta = \frac{\vec{a} \cdot \vec{b}}{|\vec{a}| |\vec{b}|} = \frac{(-1)(6) + (4)(-2)}{\sqrt{1 + 16} \sqrt{36 + 4}} = \frac{-14}{\sqrt{680}}$$

$$\theta \doteq 123^\circ$$

$$\text{c. } \cos \theta = \frac{\vec{a} \cdot \vec{b}}{|\vec{a}| |\vec{b}|} = \frac{(2)(2) + (2)(1) + (1)(-2)}{\sqrt{4 + 4 + 1} \sqrt{4 + 1 + 4}} = \frac{4}{(3)(3)} = \frac{4}{9}$$

$$\theta \doteq 64^\circ$$

$$\text{d. } \cos \theta = \frac{\vec{a} \cdot \vec{b}}{|\vec{a}| |\vec{b}|} = \frac{(2)(-5) + (3)(0) + (-6)(12)}{\sqrt{4 + 9 + 36} \sqrt{25 + 144}} = \frac{-82}{(7)(13)} = \frac{-82}{91}$$

$$\theta \doteq 154^\circ$$

$$7. \text{ a. } \vec{a} \cdot \vec{b} = |\vec{a}| |\vec{b}| \cos \theta$$

$$(-1)(-6k) + (2)(-1) + (-3)(k) = |\vec{a}| |\vec{b}| \cos(90^\circ)$$

$$6k - 2 - 3k = 0$$

$$3k = 2$$

$$k = \frac{2}{3}$$

$$\text{b. } \vec{a} \cdot \vec{b} = |\vec{a}| |\vec{b}| \cos \theta$$

$$(1)(0) + (1)(k) = \sqrt{1 + 1} \sqrt{k^2} \cos(45^\circ)$$

$$k = \sqrt{2} |k| \frac{1}{\sqrt{2}}$$

$$k = |k|$$

$$k \geq 0$$

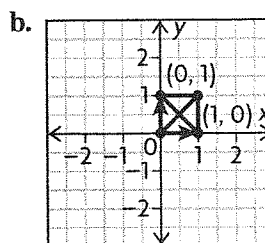
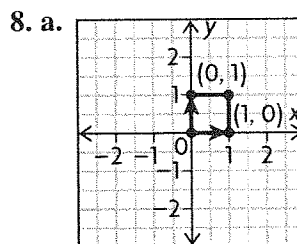

The diagonals are $(1, 0) + (0, 1) = (1, 1)$ and $(1, 0) - (0, 1) = (1, -1)$ or $(1, 0) + (0, 1) = (1, 1)$ and $(0, 1) - (1, 0) = (-1, 0)$.

$$\begin{aligned} \text{c. } (1, 1) \cdot (1, -1) &= 1 - 1 \\ &= 0 \end{aligned}$$

$$\begin{aligned} \text{or } (1, 1) \cdot (-1, 1) &= -1 + 1 \\ &= 0 \end{aligned}$$

$$\begin{aligned} 9. \text{ a. } \cos \theta &= \frac{\vec{a} \cdot \vec{b}}{|\vec{a}||\vec{b}|} \\ &= \frac{(1 - \sqrt{2})(1) + (\sqrt{2} - 1)(1)}{|\vec{a}||\vec{b}|} \\ &= 0 \end{aligned}$$

$$\theta = 90^\circ$$

$$\begin{aligned} \text{b. } \cos \theta &= \frac{\vec{a} \cdot \vec{b}}{|\vec{a}||\vec{b}|} \\ &= \frac{\sqrt{2} - 1 + \sqrt{2} + 1 + \sqrt{2}}{\sqrt{(2 - 2\sqrt{2} + 1) + (2 + 2\sqrt{2} + 1) + 2\sqrt{1 + 1 + 1}}} \\ &= \frac{3\sqrt{2}}{\sqrt{8}\sqrt{3}} \\ &= \frac{\sqrt{3}}{2} \end{aligned}$$

$$\theta = 30^\circ$$

$$10. \text{ a. i. } \vec{a} = k\vec{b}$$

$$8 = 12k$$

$$k = \frac{2}{3}$$

$$p = 4\left(\frac{2}{3}\right)$$

$$p = \frac{8}{3}$$

$$2 = \frac{2}{3}q$$

$$q = 3$$

ii. Answers may vary. For example:

$$\vec{a} \cdot \vec{b} = 0$$

$$2q + 4p + 96 = 0$$

$$q = -2p - 48$$

$$\text{Let } p = 1$$

$$q = -50$$

b. In part **a.**, the values are unique because both vectors have their third component specified, and the ratios must be the same for each component \vec{b} . In part **b.** the values are not unique; any value of p could have been chosen, each resulting in a different value of q .

$$11. \vec{AB} = (2, 6), \vec{BC} = (-5, -5), \vec{CA} = (3, -1)$$

$$\begin{aligned} \cos(180^\circ - \theta_A) &= \frac{\vec{AB} \cdot \vec{CA}}{|\vec{AB}||\vec{CA}|} \\ &= \frac{6 - 6}{6 \cdot 6} \\ &= \frac{0}{36} \\ &= 0 \end{aligned}$$

$$180^\circ - \theta_A = 90^\circ$$

$$\theta_A = 90^\circ$$

$$\begin{aligned} \cos(180^\circ - \theta_B) &= \frac{\vec{AB} \cdot \vec{BC}}{|\vec{AB}||\vec{BC}|} \\ &= \frac{-10 - 30}{\sqrt{4 + 36}\sqrt{25 + 25}} \\ &= \frac{-40}{\sqrt{(40)(50)}} \end{aligned}$$

$$= -\sqrt{\frac{4}{5}}$$

$$180^\circ - \theta_B \doteq 153.4^\circ$$

$$\theta_B \doteq 26.6^\circ$$

$$\theta_C = 180^\circ - \theta_A - \theta_B$$

$$\theta_C \doteq 63.4^\circ$$

12. a. $O = (0, 0, 0)$, $A = (7, 0, 0)$, $B = (7, 4, 0)$, $C = (0, 4, 0)$, $D = (7, 0, 5)$, $E = (0, 4, 5)$, $F = (0, 0, 5)$

$$\begin{aligned} \text{b. } \vec{AE} \cdot \vec{BF} &= |\vec{AE}||\vec{BF}|\cos \theta \\ (-7, 4, 5) \cdot (-7, -4, 5) &= \sqrt{49 + 16 + 25} \\ &\quad \times \sqrt{49 + 16 + 25} \cos \theta \\ 49 - 16 + 25 &= 90 \cos \theta \\ \frac{58}{90} &= \cos \theta \\ \theta &\doteq 50^\circ \end{aligned}$$

13. a. Answers may vary. For example:

$$(x, y, z) \cdot (-1, 3, 0) = 0$$

$$-x + 3y = 0$$

$$x = 3y$$

$$(x, y, z) \cdot (1, -5, 2) = 0$$

$$x - 5y + 2z = 0$$

$$-2y + 2z = 0$$

$$y = z$$

$$\text{Let } y = 1.$$

$(3, 1, 1)$ is perpendicular to $(-1, 3, 0)$ and

$(1, -5, 2)$.

b. Answers may vary. For example:

$$(x, y, z) \cdot (1, 3, -4) = 0$$

$$x + 3y - 4z = 0$$

$$x = 4z - 3y$$

$$(x, y, z) \cdot (-1, -2, 3) = 0$$

$$\begin{aligned} -x - 2y + 3z &= 0 \\ 3y - 4z - 2y + 3z &= 0 \\ y &= z \end{aligned}$$

$$\text{Let } y = 1.$$

(1, 1, 1) is perpendicular to (1, 3, -4) and (-1, -2, 3).

$$\begin{aligned} 14. (p, p, 1) \cdot (p, -2, -3) &= 0 \\ p^2 - 2p - 3 &= 0 \end{aligned}$$

$$p = \frac{2 \pm \sqrt{2^2 - 4(-3)}}{2}$$

$$\begin{aligned} p &= 1 \pm 2 \\ p &= 3 \text{ or } -1 \end{aligned}$$

$$\begin{aligned} 15. \text{ a. } (-3, p, -1) \cdot (1, -4, q) &= 0 \\ -3 - 4p - q &= 0 \\ 3 + 4p + q &= 0 \end{aligned}$$

$$\begin{aligned} \text{b. } 3 + 4p - 3 &= 0 \\ p &= 0 \end{aligned}$$

16. Answers may vary. For example: Note that $\vec{s} = -2\vec{r}$, so they are collinear. Therefore any vector that is perpendicular to \vec{s} is also perpendicular to \vec{r} .

$$\begin{aligned} (x, y, z) \cdot (1, 2, -1) &= 0 \\ x + 2y - z &= 0 \end{aligned}$$

$$\text{Let } x = z = 1.$$

(1, 0, 1) is perpendicular to (1, 2, -1) and (-2, -4, 2).

$$\text{Let } x = y = 1.$$

(1, 1, 3) is perpendicular to (1, 2, -1) and (-2, -4, 2).

$$17. \vec{x} \cdot \vec{y} = |\vec{x}||\vec{y}|\cos \theta$$

$$(-4, p, -2) \cdot (-2, 3, 6)$$

$$= \sqrt{16 + p^2 + 4}\sqrt{4 + 9 + 36} \cos \theta$$

$$8 + 3p - 12 = \sqrt{20 + p^2}(7) \cos \theta$$

$$(3p - 4)^2 = \left(7\sqrt{20 + p^2} \cos \theta\right)^2$$

$$9p^2 - 24p + 16 = 49(20 + p^2)\left(\frac{4}{21}\right)^2$$

$$9p^2 - 24p + 16 = \frac{320}{9} + \frac{16}{9}p^2$$

$$65p^2 - 216p - 176 = 0$$

$$p = \frac{216 \pm \sqrt{(-216)^2 - 4(65)(-176)}}{2(65)}$$

$$p = 4 \text{ or } -\frac{44}{65}$$

$$\begin{aligned} 18. \text{ a. } \vec{a} \cdot \vec{b} &= -3 + 3 \\ &= 0 \end{aligned}$$

Therefore, since the two diagonals are perpendicular, all the sides must be the same length.

$$\begin{aligned} \text{b. } \vec{AB} &= \frac{1}{2}(\vec{a} + \vec{b}) \\ &= (1, 2, -1) \end{aligned}$$

$$\begin{aligned} \vec{BC} &= \frac{1}{2}(\vec{a} - \vec{b}) \\ &= (2, 1, 1) \end{aligned}$$

$$|\vec{AB}| = |\vec{BC}| = \sqrt{6}$$

$$\begin{aligned} \text{c. } \vec{AB} \cdot \vec{BC} &= |\vec{AB}||\vec{BC}|\cos \theta_1 \\ 2 + 2 - 1 &= 6 \cos \theta_1 \end{aligned}$$

$$\frac{1}{2} = \cos \theta_1$$

$$\theta_1 = 60^\circ$$

$$2\theta_1 + 2\theta_2 = 360^\circ$$

$$\theta_2 = 120^\circ$$

$$19. \text{ a. } \vec{AB} = (3, 4, -12), \vec{DA} = (-4, 2 - q, -5)$$

$$\vec{AB} \cdot \vec{DA} = 0$$

$$-12 + 8 - 4q + 60 = 0$$

$$-1 - q + 15 = 0$$

$$q = 14$$

$$\vec{DA} = \vec{CB}$$

$$(-4, -12, -5) = (2 - x, 6 - y, -9 - z)$$

$$x = 6, y = 18, z = -4$$

The coordinates of vertex C are (6, 18, -4).

$$\text{b. } \vec{AC} \cdot \vec{BD} = |\vec{AC}||\vec{BD}|\cos \theta$$

$$(7, 16, -7) \cdot (1, 8, 17) = \sqrt{49 + 256 + 49}$$

$$\times \sqrt{1 + 64 + 289} \cos \theta$$

$$7 + 128 - 119 = 354 \cos \theta$$

$$\frac{16}{354} = \cos \theta$$

$$\theta \doteq 87.4^\circ$$

20. The two vectors representing the body diagonals

are $(0 - 1, 1 - 0, 1 - 0) = (-1, 1, 1)$ and

$(0 - 1, 0 - 1, 1 - 0) = (-1, -1, 1)$

$$(-1, 1, 1) \cdot (-1, -1, 1) = \sqrt{3}\sqrt{3} \cos \theta$$

$$1 - 1 + 1 = 3 \cos \theta$$

$$\frac{1}{3} = \cos \theta$$

$$\theta \doteq 70.5^\circ$$

$$\alpha = 180^\circ - \theta$$

$$\alpha \doteq 109.5^\circ$$

Mid-Chapter Review, pp. 388–389

$$1. \text{ a. } \vec{a} \cdot \vec{b} = (3)(2) \cos (60^\circ)$$

$$= (6)\frac{1}{2}$$

$$= 3$$

$$\begin{aligned} \text{b. } (3\vec{a} + 2\vec{b}) \cdot (4\vec{a} - 3\vec{b}) &= 12|\vec{a}|^2 - 9\vec{a} \cdot \vec{b} \\ &\quad + 8\vec{b} \cdot \vec{a} - 6|\vec{b}|^2 \\ &= 12(3)^2 - 3 - 6(2)^2 \\ &= 81 \end{aligned}$$

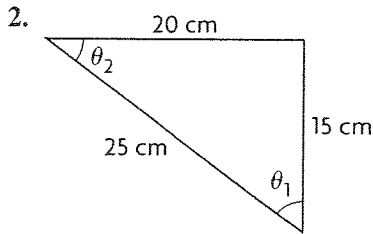

Let T_1 be the tension in the 15 cm cord and T_2 be the tension in the 20 cm cord. Let θ_1 be the angle the 15 cm cord makes with the ceiling and θ_2 be the angle the 20 cm cord makes with the ceiling. By the cosine law:

$$\begin{aligned} (15)^2 &= (20)^2 + (25)^2 - 2(20)(25)\cos(\theta_2) \\ \cos(\theta_2) &= 0.8 \\ \sin(\theta_2) &= \sqrt{1 - \cos^2(\theta_2)} \\ \sin(\theta_2) &= 0.6 \\ (20)^2 &= (15)^2 + (25)^2 - 2(15)(25)\cos(\theta_1) \\ \cos(\theta_1) &= 0.6 \\ \sin(\theta_1) &= 0.8 \end{aligned}$$

Horizontal Components:

$$\begin{aligned} -T_1 \cos(\theta_1) + T_2 \cos(\theta_2) &= 0 \\ (0.8)T_2 &= (0.6)T_1 \\ T_2 &= (0.75)T_1 \end{aligned}$$

Vertical Components:

$$\begin{aligned} T_1 \sin(\theta_1) + T_2 \sin(\theta_2) - (15)(9.8) &= 0 \\ (0.8)T_1 + (0.6)(0.75)T_1 &= 147 \\ (1.25)T_1 &= 147 \\ T_1 &= 117.6 \text{ N} \\ T_2 &= (0.75)T_1 \\ T_2 &= 88.2 \text{ N} \end{aligned}$$

Therefore the tension in the 15 cm cord is 117.60 N and the tension in the 20 cm cord is 88.20 N.

3. The diagonals of a square are perpendicular, so the dot product is 0.

4. a.

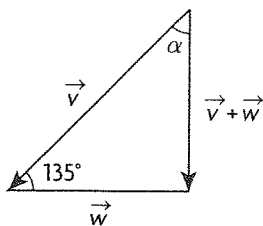

$$|\vec{v}| = 500, |\vec{w}| = 100$$

By the cosine law:

$$\begin{aligned} |\vec{v} + \vec{w}|^2 &= (500)^2 + (100)^2 \\ &\quad - 2(500)(100)\cos(135^\circ) \end{aligned}$$

$$|\vec{v} + \vec{w}| \doteq 575.1$$

By the cosine law:

$$\frac{\sin(\alpha)}{100} = \frac{\sin(135^\circ)}{575.1}$$

$$\sin(\alpha) \doteq 0.123$$

$$\alpha \doteq 7.06^\circ$$

The resultant velocity of the airplane is 575.1 km/h at $7.06^\circ E$

b. (distance) = (rate)(time)

$$t \doteq \frac{1000}{575.1} \cdot \frac{\text{km}}{(\text{km/h})}$$

$$t \doteq 1.74 \text{ hours}$$

5. a.

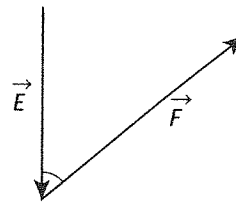

$$|\vec{E}_\perp| = |\vec{E}| \cos(40^\circ)$$

$$|\vec{E}_\perp| = (9.8)(15)\cos(40^\circ)$$

$$|\vec{E}_\perp| \doteq 112.61 \text{ N}$$

$$\text{b. } |\vec{F}| = |\vec{E}| \sin(40^\circ)$$

$$|\vec{F}| \doteq 94.49 \text{ N}$$

$$6. 6\theta = 360^\circ$$

$$\theta = 60^\circ$$

$$\vec{a} \cdot \vec{b} = |\vec{a}||\vec{b}|\cos(60^\circ)$$

$$= (3)(3)(0.5)$$

$$= 4.5$$

$$7. \text{ a. } \vec{a} \cdot \vec{b} = (4)(1) + (-5)(2) + (20)(2)$$

$$= 34$$

$$\text{b. } \vec{a} \cdot \vec{b} = |\vec{a}||\vec{b}|\cos(\theta)$$

$$34 = \sqrt{16 + 25 + 400} \sqrt{1 + 4 + 4} \cos(\theta)$$

$$\cos(\theta) = \frac{34}{63}$$

$$8. \text{ a. } \vec{a} \cdot \vec{b} = (\vec{i} + 2\vec{j} + \vec{k}) \cdot (2\vec{i} - 3\vec{j} + 4\vec{k})$$

$$= 2 - 6 + 4$$

$$= 0$$

$$\text{b. } \vec{b} \cdot \vec{c} = (2\vec{i} - 3\vec{j} + 4\vec{k}) \cdot (3\vec{i} - \vec{j} - \vec{k})$$

$$= 6 + 3 - 4$$

$$= 5$$

$$\text{c. } \vec{b} + \vec{c} = (2\vec{i} - 3\vec{j} + 4\vec{k}) + (3\vec{i} - \vec{j} - \vec{k})$$

$$= 5\vec{i} - 4\vec{j} + 3\vec{k}$$

$$\text{d. } \vec{a} \cdot (\vec{b} + \vec{c}) = (\vec{i} + 2\vec{j} + \vec{k}) \cdot (5\vec{i} - 4\vec{j} + 3\vec{k})$$

$$= 5 - 8 + 3$$

$$= 0$$

$$\text{e. } (\vec{a} + \vec{b}) \cdot (\vec{b} + \vec{c}) = (3\vec{i} - \vec{j} + 5\vec{k})$$

$$\cdot (5\vec{j} - 4\vec{j} + 3\vec{k})$$

$$= 15 + 4 + 15$$

$$= 34$$

$$\begin{aligned}
 \text{f. } (2\vec{a} - 3\vec{b}) \cdot (2\vec{a} + \vec{c}) &= ((2\vec{i} + 4\vec{j} + 2\vec{k}) \\
 &\quad - (6\vec{i} - 9\vec{j} + 12\vec{k})) \\
 &\quad \cdot ((2\vec{i} + 4\vec{j} + 2\vec{k}) \\
 &\quad + (3\vec{i} - \vec{j} + \vec{k})) \\
 &= (-4\vec{i} + 13\vec{j} - 10\vec{k}) \\
 &\quad \cdot (5\vec{i} + 3\vec{j} + \vec{k}) \\
 &= -20 + 39 - 10 \\
 &= 9
 \end{aligned}$$

$$9. \text{ a. } \vec{p} \cdot \vec{q} = 0$$

$$(x\vec{i} + \vec{j} + 3\vec{k}) \cdot (3x\vec{i} + 10x\vec{j} + \vec{k}) = 0$$

$$3x^2 + 10x + 3 = 0$$

$$x = \frac{-10 \pm \sqrt{(10)^2 - 4(3)(3)}}{2(3)}$$

$$x = \frac{-10 \pm 8}{6}$$

$$x = -3 \text{ or } x = -\frac{1}{3}$$

b. If \vec{p} and \vec{q} are parallel then one is a scalar multiple of the other.

$$\vec{p} = n\vec{q} \text{ where } n \text{ is a constant}$$

$$x\vec{i} + \vec{j} + 3\vec{k} = n(3x\vec{i} + 10x\vec{j} + \vec{k})$$

$$n = 3 \text{ by the } \vec{k} \text{ component}$$

$$x = 9x \text{ by the } \vec{i} \text{ component}$$

$$x = 0$$

$$1 = 30(0) \text{ by the } \vec{j} \text{ component}$$

$$1 \neq 0$$

Therefore there is no value of x that will make these two vectors parallel.

$$10. \text{ a. } 3\vec{x} - 2\vec{y} = (3\vec{i} - 6\vec{j} - 3\vec{k}) - (2\vec{i} - 2\vec{j} - 2\vec{k})$$

$$= \vec{i} - 4\vec{j} - \vec{k}$$

$$\text{b. } 3\vec{x} \cdot 2\vec{y} = (3\vec{i} - 6\vec{j} - 3\vec{k}) \cdot (2\vec{i} - 2\vec{j} - 2\vec{k})$$

$$= 6 + 12 + 6$$

$$= 24$$

$$\text{c. } |\vec{x} - 2\vec{y}| = |(\vec{i} - 2\vec{j} - \vec{k}) - (2\vec{i} - 2\vec{j} - 2\vec{k})|$$

$$= |-\vec{i} + \vec{k}|$$

$$= \sqrt{(-\vec{i} + \vec{k}) \cdot (-\vec{i} + \vec{k})}$$

$$= \sqrt{2} \text{ or } 1.41$$

$$\text{d. } (2\vec{x} - 3\vec{y}) \cdot (\vec{x} + 4\vec{y}) = ((2\vec{i} - 4\vec{j} - 2\vec{k})$$

$$\quad - (3\vec{i} - 3\vec{j} - 3\vec{k})) \cdot$$

$$\quad + ((\vec{i} - 2\vec{j} - \vec{k})$$

$$\quad + (4\vec{i} - 4\vec{j} - 4\vec{k}))$$

$$= (-\vec{i} - \vec{j} + \vec{k})$$

$$\quad \cdot (5\vec{i} - 6\vec{j} - 5\vec{k})$$

$$= -5 + 6 - 5$$

$$= -4$$

$$\begin{aligned}
 \text{e. } 2\vec{x} \cdot \vec{y} - 5\vec{y} \cdot \vec{x} &= 2\vec{x} \cdot \vec{y} - 5\vec{x} \cdot \vec{y} \\
 &= -3\vec{x} \cdot \vec{y} \\
 &= -3(\vec{i} - 2\vec{j} - \vec{k}) \cdot (\vec{i} - \vec{j} - \vec{k}) \\
 &= -3(1 + 2 + 1) \\
 &= -12
 \end{aligned}$$

11.

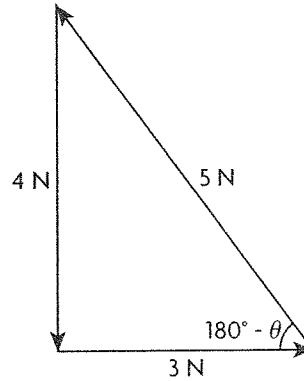

$$(4)^2 = (5)^2 + (3)^2 - 2(3)(5)\cos(180^\circ - \theta)$$

$$0.6 = \cos(180^\circ - \theta)$$

$$180^\circ - \theta \doteq 53.1$$

$$\theta \doteq 126.9^\circ$$

$$12. (F)^2 = (3)^2 + (4)^2 - 2(3)(4)\cos(180^\circ - 60^\circ)$$

$$(F)^2 = 25 - 24\cos(120^\circ)$$

$$(F)^2 = 37$$

$$F \doteq 6.08 \text{ N}$$

$$(3)^2 = (4)^2 + (\sqrt{37})^2 - 2(4)(\sqrt{37})\cos\theta$$

$$\cos\theta = \frac{44}{8\sqrt{37}}$$

$$\theta \doteq 25.3^\circ$$

$\vec{F} \doteq 6.08 \text{ N}$, 25.3° from the 4 N force towards the 3 N force.

$\vec{E} \doteq 6.08 \text{ N}$, $180^\circ - 25.3^\circ = 154.7^\circ$ from the 4 N force away from the 3 N force.

13. a. The diagonals are $\vec{m} + \vec{n}$ and $\vec{m} - \vec{n}$

$$\vec{m} + \vec{n} = (1, 4, 10)$$

$$\vec{m} - \vec{n} = (3, -10, 0)$$

$$(\vec{m} + \vec{n}) \cdot (\vec{m} - \vec{n}) = |\vec{m} + \vec{n}||\vec{m} - \vec{n}|\cos\theta$$

$$3 - 40 = \sqrt{1 + 16 + 100}\sqrt{9 + 100}\cos\theta$$

$$\cos\theta \doteq -0.3276$$

$$\theta \doteq 109.1^\circ$$

$$\text{b. } |\vec{m} - \vec{n}|^2 = |\vec{m}|^2 + |\vec{n}|^2 - 2|\vec{m}||\vec{n}|\cos\theta$$

$$(9 + 100) = (4 + 9 + 25) + (1 + 49 + 25)$$

$$-2\sqrt{38}\sqrt{75}\cos\theta$$

$$\cos\theta \doteq 0.0374$$

$$\theta \doteq 87.9^\circ$$

14. a. $45 \sin(150^\circ) = 500 \sin \theta$
 $\theta \doteq \text{N } 2.6^\circ \text{ E}$

b. $v = 500 \cos(2.6^\circ) - 45 \cos(30^\circ)$
 $\doteq 460.5 \text{ km/h}$

$t \doteq \frac{1000}{460.5}$

$t \doteq 2.17 \text{ hours}$

15. $\vec{a} \cdot \vec{x} = 0$

$-x_1 + 2x_2 + 5x_3 = 0$

$x_1 = 2x_2 + 5x_3$

$\vec{b} \cdot \vec{x} = 0$

$x_1 + 3x_2 + 5x_3 = 0$

$2x_2 + 5x_3 + 3x_2 + 5x_3 = 0$

$x_2 + 2x_3 = 0$

choose $x_3 = 1$

$x_2 = -2$

$x_1 = 1$

$\vec{x} = \frac{1}{\sqrt{6}}(1, -2, 1)$

$\vec{x} = \left(\frac{1}{\sqrt{6}}, -\frac{2}{\sqrt{6}}, \frac{1}{\sqrt{6}} \right)$ or $\left(-\frac{1}{\sqrt{6}}, \frac{2}{\sqrt{6}}, -\frac{1}{\sqrt{6}} \right)$

16. a. $v = 4 + 3 \cos(45^\circ)$

$\doteq 6.12 \text{ m/s}$

$d \doteq (6.12)(10)$

$\doteq 61.2 \text{ m}$

b. $w = 3 \sin(45^\circ)$

$\doteq 2.12 \text{ m/s}$

$t \doteq \frac{180}{2.12}$

$t \doteq 84.9 \text{ seconds}$

17. a. $(\vec{x} + \vec{y}) \cdot (\vec{x} - \vec{y}) = 0$

$|\vec{x}|^2 - \vec{x} \cdot \vec{y} + \vec{y} \cdot \vec{x} - |\vec{y}|^2 = 0$

$|\vec{x}|^2 = |\vec{y}|^2$

$(\vec{x} + \vec{y}) \cdot (\vec{x} - \vec{y}) = 0$ when \vec{x} and \vec{y} have

the same length.

b. Vectors \vec{a} and \vec{b} determine a parallelogram. Their sum $\vec{a} + \vec{b}$ is one diagonal of the parallelogram formed, with its tail in the same location as the tails of \vec{a} and \vec{b} . Their difference $\vec{a} - \vec{b}$ is the other diagonal of the parallelogram.

18. $|\vec{F}| = 350 \cos(40^\circ)$

$\doteq 268.12 \text{ N}$

7.5 Scalar and Vector Projections, pp. 398–400

1. a. Scalar projection of \vec{a} on \vec{b} is $\frac{\vec{a} \cdot \vec{b}}{|\vec{b}|}$ where

$\vec{a} = (2, 3)$ and \vec{b} is the positive x -axis $(X, 0)$.

$\vec{a} \cdot \vec{b} = (2X) + (3 \times 0)$

$= 2X + 0$

$= 2X$

$|\vec{b}| = \sqrt{X^2 + 0^2}$

$= X$

$\frac{\vec{a} \cdot \vec{b}}{|\vec{b}|} = \frac{2X}{X}$

$= 2;$

The vector projection is the scalar projection

multiplied by $\frac{\vec{b}}{|\vec{b}|}$ where $\frac{\vec{b}}{|\vec{b}|}$ is the x -axis divided by

the magnitude of the x -axis which is equal to \vec{i} .

The scalar projection of 2 multiplied by \vec{i} equals $2\vec{i}$.

b. Scalar projection of \vec{a} on \vec{b} is $\frac{\vec{a} \cdot \vec{b}}{|\vec{b}|}$ where

$\vec{a} = (2, 3)$ and \vec{b} is now the positive y -axis $(0, Y)$.

$\vec{a} \cdot \vec{b} = (2 \times 0) + (3Y)$

$= 0 + 3Y$

$= 3Y$

$|\vec{b}| = \sqrt{0^2 + Y^2}$

$= Y$

$\frac{\vec{a} \cdot \vec{b}}{|\vec{b}|} = \frac{3Y}{Y}$

$= 3;$

The vector projection is the scalar projection

multiplied by $\frac{\vec{b}}{|\vec{b}|}$ where $\frac{\vec{b}}{|\vec{b}|}$ is the y -axis divided

by the magnitude of the y -axis which is equal to \vec{j} .

The scalar projection of 3 multiplied by \vec{j} equals $3\vec{j}$.

2. Using the formula would cause a division by 0.

Generally the $\vec{0}$ has any direction and 0 magnitude.

You can not project onto nothing.

3. You are projecting \vec{a} onto the tail of \vec{b} which is a point with magnitude 0. Therefore it is $\vec{0}$; the projections of \vec{b} onto the tail of \vec{a} are also 0 and $\vec{0}$.

4. Answers may vary. For example: $\vec{p} = \overline{AE}$,
 $\vec{q} = \overline{AB}$

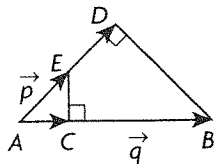

Scalar projection \vec{p} on $\vec{q} = |\overline{AC}|$;

Vector projection \vec{p} on $\vec{q} = \overline{AC}$;

Scalar projection \vec{q} on $\vec{p} = |\overline{AD}|$;

Vector projection \vec{q} on $\vec{p} = \overline{AD}$

5. When $\vec{a} = (-1, 2, 5)$ and $\vec{b} = (1, 0, 0)$ then

$$\vec{a} \cdot \vec{b} = (-1 \times 1 + 2 \times 0 + 5 \times 0)$$

$$= -1$$

$$|\vec{b}| = \sqrt{1^2 + 0^2 + 0^2}$$

$$= 1$$

Therefore the scalar projection is $\frac{\vec{a} \cdot \vec{b}}{|\vec{b}|} = \frac{-1}{1}$
 $= -1$;

The vector equation is $-1 \times \frac{\vec{b}}{|\vec{b}|} = -1 \times \frac{(1, 0, 0)}{1}$
 $= -1$;

Under the same approach, when $\vec{a} = (-1, 2, 5)$
and $\vec{b} = (0, 1, 0)$, then

$$\vec{a} \cdot \vec{b} = (-1 \times 0 + 2 \times 1 + 5 \times 0)$$

$$= 2$$

$$|\vec{b}| = \sqrt{0^2 + 1 + 0^2}$$

$$= 1$$

Therefore the scalar projection is $\frac{\vec{a} \cdot \vec{b}}{|\vec{b}|} = \frac{2}{1}$
 $= 2$,

The vector equation is $2 \times \frac{\vec{b}}{|\vec{b}|} = 2 \times \frac{(0, 1, 0)}{1}$
 $= 2$;

The same is also true when $\vec{a} = (-1, 2, 5)$ and
 $\vec{b} = (0, 0, 1)$ then

$$\vec{a} \cdot \vec{b} = (-1 \times 0 + 2 \times 0 + 5 \times 1)$$

$$= 5$$

$$|\vec{b}| = \sqrt{0^2 + 0^2 + 1^2}$$

$$= 1$$

Therefore the scalar projection is $\frac{\vec{a} \cdot \vec{b}}{|\vec{b}|} = \frac{5}{1}$
 $= 5$,

The vector equation is $5 \times \frac{\vec{b}}{|\vec{b}|} = 5 \times \frac{(0, 0, 1)}{1}$
 $= 5$;

Without having to use formulae, a projection of
 $(-1, 2, 5)$ on \vec{i} , \vec{j} , or \vec{k} is the same as a projection
of $(-1, 0, 0)$ on \vec{i} , $(0, 2, 0)$ on \vec{j} , and $(0, 0, 5)$ on \vec{k}
which intuitively yields the same result.

$$6. \text{ a. } \vec{p} \cdot \vec{q} = (3 \times -4) + (6 \times 5)$$

$$+ (-22 \times -20)$$

$$= -12 + 30 + 440$$

$$= 458$$

$$|\vec{q}| = \sqrt{(-4)^2 + 5^2 + (-20)^2}$$

$$= \sqrt{16 + 25 + 400}$$

$$= \sqrt{441}$$

$$= 21$$

Therefore the scalar projection is $\frac{\vec{p} \cdot \vec{q}}{|\vec{q}|} = \frac{458}{21}$,

$$\text{The vector equation} = \frac{458}{21} \times \frac{\vec{q}}{|\vec{q}|}$$

$$= \frac{458}{21} \frac{(-4, 5, -20)}{21}$$

$$= \frac{458}{441}(-4, 5, 20).$$

b. Direction angles for \vec{p} where $\vec{p} = (a, b, c)$

$$\text{include } \alpha, \beta, \text{ and } \gamma. \cos \alpha = \frac{a}{\sqrt{a^2 + b^2 + c^2}}$$

$$= \frac{3}{\sqrt{3^2 + 6^2 + (-22)^2}}$$

$$= \frac{3}{\sqrt{9 + 36 + 484}}$$

$$= \frac{3}{\sqrt{529}}$$

$$= \frac{3}{23},$$

$$\text{Therefore } \alpha = \cos^{-1} \left(\frac{3}{23} \right)$$

$$\doteq 82.5^\circ;$$

$$\cos \beta = \frac{b}{\sqrt{a^2 + b^2 + c^2}}$$

$$= \frac{6}{\sqrt{3^2 + 6^2 + (-22)^2}}$$

$$= \frac{6}{\sqrt{9 + 36 + 484}}$$

$$= \frac{6}{\sqrt{529}}$$

$$= \frac{6}{23},$$

$$\text{Therefore } \beta = \cos^{-1} \left(\frac{6}{23} \right)$$

$$\doteq 74.9^\circ;$$

$$\begin{aligned}\cos \gamma &= \frac{c}{\sqrt{a^2 + b^2 + c^2}} \\ &= \frac{-22}{\sqrt{3^2 + 6^2 + (-22)^2}} \\ &= \frac{-22}{\sqrt{9 + 36 + 484}} \\ &= \frac{-22}{\sqrt{529}} \\ &= \frac{-22}{23},\end{aligned}$$

$$\begin{aligned}\text{Therefore } \gamma &= \cos^{-1}\left(\frac{-22}{23}\right) \\ &\approx 163.0^\circ\end{aligned}$$

$$\begin{aligned}7. \text{ a. } \vec{x} \cdot \vec{y} &= (1 \times 1) + (1 \times -1) \\ &= 1 + (-1) \\ &= 0 \\ |\vec{y}| &= \sqrt{1^2 + (-1)^2} \\ &= \sqrt{2}\end{aligned}$$

$$\begin{aligned}\text{The scalar projection is } \frac{\vec{x} \cdot \vec{y}}{|\vec{y}|} &= \frac{0}{\sqrt{2}} \\ &= 0;\end{aligned}$$

$$\text{The vector projection is } 0 \times \frac{\vec{y}}{|\vec{y}|} = \vec{0}$$

$$\begin{aligned}\text{b. } \vec{x} \cdot \vec{y} &= (2 \times 1) + (2\sqrt{3} \times 0) \\ &= 2 \\ |\vec{y}| &= \sqrt{1^2 + 0^2} \\ &= 1\end{aligned}$$

$$\begin{aligned}\text{The scalar projection is } \frac{\vec{x} \cdot \vec{y}}{|\vec{y}|} &= \frac{2}{1} \\ &= 2;\end{aligned}$$

$$\begin{aligned}\text{The vector projection is } 2 \times \frac{\vec{y}}{|\vec{y}|} &= 2 \times \frac{(1, 0)}{1} \\ &= 2\vec{i}\end{aligned}$$

$$\begin{aligned}\text{c. } \vec{x} \cdot \vec{y} &= (2 \times -5) + (5 \times 12) \\ &= -10 + 60 \\ &= 50 \\ |\vec{y}| &= \sqrt{(-5)^2 + 12^2} \\ &= \sqrt{25 + 144} \\ &= \sqrt{169} \\ &= 13\end{aligned}$$

$$\text{The scalar projection is } \frac{\vec{x} \cdot \vec{y}}{|\vec{y}|} = \frac{50}{13}.$$

$$\begin{aligned}\text{The vector projection is } \frac{50}{13} \times \frac{\vec{y}}{|\vec{y}|} &= \frac{50}{13} \times \frac{(-5, 12)}{13} \\ &= \frac{50}{169}(-5, 12)\end{aligned}$$

8. a. The scalar projection of \vec{a} on the x -axis

$$(X, 0, 0) \text{ is } \frac{\vec{a} \cdot (X, 0, 0)}{|(X, 0, 0)|}$$

$$\begin{aligned}\frac{\vec{a} \cdot (X, 0, 0)}{|(X, 0, 0)|} &= \frac{(-1 \times X) + (2 \times 0) + (4 \times 0)}{\sqrt{X^2 + 0^2 + 0^2}} \\ &= \frac{-X}{X} \\ &= -1;\end{aligned}$$

The vector projection of \vec{a} on the x -axis is

$$\begin{aligned}-1 \times \frac{(X, 0, 0)}{\sqrt{X^2 + 0^2 + 0^2}} &= -1 \times \frac{(X, 0, 0)}{X} \\ &= -\vec{i};\end{aligned}$$

The scalar projection of \vec{a} on the y -axis $(0, Y, 0)$ is

$$\begin{aligned}\frac{\vec{a} \cdot (0, Y, 0)}{|(0, Y, 0)|} &= \frac{(-1 \times 0) + (2 \times Y) + (4 \times 0)}{\sqrt{0^2 + Y^2 + 0^2}} \\ &= \frac{2Y}{Y} \\ &= 2\end{aligned}$$

The vector projection of \vec{a} on the y -axis is

$$\begin{aligned}2 \times \frac{(0, Y, 0)}{\sqrt{0^2 + Y^2 + 0^2}} &= 2 \times \frac{(0, Y, 0)}{Y} \\ &= 2\vec{j};\end{aligned}$$

The scalar projection of \vec{a} on the z -axis $(0, 0, Z)$ is

$$\begin{aligned}\frac{\vec{a} \cdot (0, 0, Z)}{|(0, 0, Z)|} &= \frac{(-1 \times 0) + (2 \times 0) + (4 \times Z)}{\sqrt{0^2 + 0^2 + Z^2}} \\ &= \frac{4Z}{Z} \\ &= 4;\end{aligned}$$

The vector projection of \vec{a} on the z -axis is

$$\begin{aligned}4 \times \frac{(0, 0, Z)}{\sqrt{0^2 + 0^2 + Z^2}} &= 4 \times \frac{(0, 0, Z)}{Z} \\ &= 4\vec{k}.\end{aligned}$$

b. The scalar projection of $m\vec{a}$ on the x -axis

$(X, 0, 0)$ is

$$\begin{aligned}\frac{m\vec{a} \cdot (X, 0, 0)}{|(X, 0, 0)|} &= \frac{(-m \times X) + (2m \times 0)}{\sqrt{X^2 + 0^2 + 0^2}} \\ &\quad + \frac{(4m \times 0)}{\sqrt{X^2 + 0^2 + 0^2}} \\ &= \frac{-mX}{X} \\ &= -m\end{aligned}$$

The vector projection of $m\vec{a}$ on the x -axis is

$$\begin{aligned}-m \times \frac{(X, 0, 0)}{\sqrt{X^2 + 0^2 + 0^2}} &= -m \times \frac{(X, 0, 0)}{X} \\ &= -m\vec{i};\end{aligned}$$

The scalar projection of $m\vec{a}$ on the y-axis $(0, Y, 0)$ is

$$\begin{aligned} \frac{m\vec{a} \cdot (0, Y, 0)}{|(0, Y, 0)|} &= \frac{(-m \times 0) + (2m \times Y)}{\sqrt{0^2 + Y^2 + 0^2}} \\ &+ \frac{(4m \times 0)}{\sqrt{0^2 + Y^2 + 0^2}} \\ &= \frac{2mY}{Y} \\ &= 2m; \end{aligned}$$

The vector projection of $m\vec{a}$ on the y-axis is

$$2m \times \frac{(0, Y, 0)}{\sqrt{0^2 + Y^2 + 0^2}} = 2m \times \frac{(0, Y, 0)}{Y} = 2m\vec{j};$$

The scalar projection of $m\vec{a}$ on the z-axis $(0, 0, Z)$ is

$$\begin{aligned} \frac{m\vec{a} \cdot (0, 0, Z)}{|(0, 0, Z)|} &= \frac{(-m \times 0) + (2m \times 0)}{\sqrt{0^2 + 0^2 + Z^2}} \\ &+ \frac{(4m \times Z)}{\sqrt{0^2 + 0^2 + Z^2}} \\ &= \frac{4mZ}{Z} \\ &= 4m; \end{aligned}$$

The vector projection of $m\vec{a}$ on the z-axis is

$$4m \times \frac{(0, 0, Z)}{\sqrt{0^2 + 0^2 + Z^2}} = 4m \times \frac{(0, 0, Z)}{Z} = 4m\vec{k}.$$

9. a.

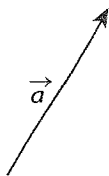

\vec{a} projected onto itself will yield itself. The scalar projection will be the magnitude of itself.

b. Using the formula for the scalar projection

$$\begin{aligned} |\vec{a}|\cos\theta &= |\vec{a}|\cos 0 \\ &= |\vec{a}|(1) \\ &= |\vec{a}|. \end{aligned}$$

The vector projection is the scalar projection

multiplied by $\frac{\vec{a}}{|\vec{a}|}$, $|\vec{a}| \times \frac{\vec{a}}{|\vec{a}|} = \vec{a}$.

10. a. 

b.
$$\frac{(-\vec{a}) \cdot \vec{a}}{|\vec{a}|} = \frac{-|\vec{a}|^2}{|\vec{a}|} = -|\vec{a}|$$

So the vector projection is $-|\vec{a}|\left(\frac{|\vec{a}|}{|\vec{a}|}\right) = -\vec{a}$.

11. a. \overline{AB} = Point B - Point A

$$\begin{aligned} &= (-1, 3, 4) - (1, 2, 2) \\ &= (-2, 1, 2) \end{aligned}$$

The scalar projection of \overline{AB} on the x-axis $(X, 0, 0)$ is

$$\begin{aligned} \frac{\vec{a} \cdot (X, 0, 0)}{|(X, 0, 0)|} &= \frac{(-2 \times X) + (1 \times 0) + (2 \times 0)}{\sqrt{X^2 + 0^2 + 0^2}} \\ &= \frac{-2X}{X} \\ &= -2; \end{aligned}$$

The vector projection of \overline{AB} on the x-axis is

$$-2 \times \frac{(X, 0, 0)}{\sqrt{X^2 + 0^2 + 0^2}} = -2 \times \frac{(X, 0, 0)}{X} = -2\vec{i};$$

The scalar projection of \overline{AB} on the y-axis $(0, Y, 0)$ is

$$\begin{aligned} \frac{\vec{a} \cdot (0, Y, 0)}{|(0, Y, 0)|} &= \frac{(-2 \times 0) + (1 \times Y) + (2 \times 0)}{\sqrt{0^2 + Y^2 + 0^2}} \\ &= \frac{Y}{Y} \\ &= 1; \end{aligned}$$

The vector projection of \overline{AB} on the y-axis is

$$1 \times \frac{(0, Y, 0)}{\sqrt{0^2 + Y^2 + 0^2}} = 1 \times \frac{(0, Y, 0)}{Y} = \vec{j};$$

The scalar projection of \overline{AB} on the z-axis $(0, 0, Z)$ is

$$\begin{aligned} \frac{\vec{a} \cdot (0, 0, Z)}{|(0, 0, Z)|} &= \frac{(-2 \times 0) + (1 \times 0) + (2 \times Z)}{\sqrt{0^2 + 0^2 + Z^2}} \\ &= \frac{2Z}{Z} \\ &= 2; \end{aligned}$$

The vector projection of \overline{AB} on the z-axis is

$$2 \times \frac{(0, 0, Z)}{\sqrt{0^2 + 0^2 + Z^2}} = 2 \times \frac{(0, 0, Z)}{Z} = 2\vec{k}$$

b. The angle made with the y-axis is β

$$\begin{aligned} \cos\beta &= \frac{b}{\sqrt{a^2 + b^2 + c^2}} \\ &= \frac{1}{\sqrt{(-2)^2 + 1^2 + 2^2}} \\ &= \frac{1}{\sqrt{4 + 1 + 4}} \\ &= \frac{1}{\sqrt{9}} \\ &= \frac{1}{3} \end{aligned}$$

Therefore $\beta = \cos^{-1}\left(\frac{1}{3}\right)$
 $\approx 70.5^\circ$

12. a. $|\overline{BD}|$

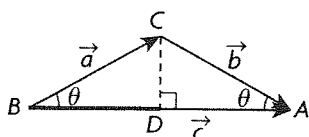

b. $|\overline{BD}|$

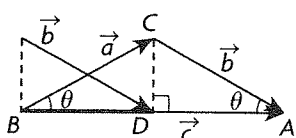

c. In an isosceles triangle, CD is a median and a right bisector of BA . Therefore \vec{a} and \vec{b} have the same magnitude projected on \vec{c} .

d. Yes, not only do they have the same magnitude, but they are in the same direction as well which makes them have equivalent vector projections.

13. a. Use the formula for the scalar projection of \vec{a} on \vec{b}

$$\begin{aligned} \vec{b} &= |\vec{a}| \cos \theta \\ &= 10 \cos 135^\circ \\ &= -7.07 \end{aligned}$$

And the formula for the scalar projection of \vec{b} on \vec{a}

$$\begin{aligned} \vec{a} &= |\vec{b}| \cos \theta \\ &= 12 \cos 135^\circ \\ &= -8.49 \end{aligned}$$

b.

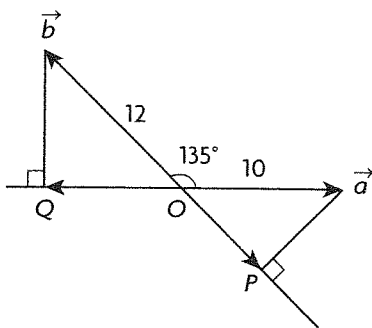

\overline{OQ} is the vector projection of \vec{b} on \vec{a}

\overline{OP} is the vector projection of \vec{a} on \vec{b}

14. a. $\overline{AB} = \text{Point B} - \text{Point A}$
 $= (1, 3, 3) - (-2, 1, 4)$
 $= (3, 2, -1)$

The scalar projection of \overline{AB} on \overline{OD} is

$$\begin{aligned} \frac{\overline{AB} \cdot \overline{OD}}{|\overline{OD}|} &= \frac{(3 \times -1) + (2 \times 2) + (-1 \times 2)}{\sqrt{(-1)^2 + 2^2 + 2^2}} \\ &= \frac{(-3) + 4 + (-2)}{\sqrt{1 + 4 + 4}} \end{aligned}$$

$$\begin{aligned} &= \frac{-1}{\sqrt{9}} \\ &= -\frac{1}{3} \end{aligned}$$

b. $\overline{BC} = \text{Point C} - \text{Point B}$
 $= (-6, 7, 5) - (1, 3, 3)$
 $= (-7, 4, 2)$

The scalar projection of \overline{BC} on \overline{OD} is

$$\begin{aligned} \frac{\overline{BC} \cdot \overline{OD}}{|\overline{OD}|} &= \frac{(-7 \times -1) + (4 \times 2) + (2 \times 2)}{\sqrt{(-1)^2 + 2^2 + 2^2}} \\ &= \frac{7 + 8 + 4}{\sqrt{1 + 4 + 4}} \\ &= \frac{19}{\sqrt{9}} \\ &= \frac{19}{3} \end{aligned}$$

$$\begin{aligned} \frac{\overline{AB} \cdot \overline{OD}}{|\overline{OD}|} + \frac{\overline{BC} \cdot \overline{OD}}{|\overline{OD}|} &= -\frac{1}{3} + \frac{19}{3} \\ &= \frac{18}{3} \\ &= 6 \end{aligned}$$

$\overline{AC} = \text{Point C} - \text{Point A}$
 $= (-6, 7, 5) - (-2, 1, 4)$
 $= (-4, 6, 1)$

The scalar projection of \overline{AC} on \overline{OD} is

$$\begin{aligned} \frac{\overline{AC} \cdot \overline{OD}}{|\overline{OD}|} &= \frac{(-4 \times -1) + (6 \times 2) + (1 \times 2)}{\sqrt{(-1)^2 + 2^2 + 2^2}} \\ &= \frac{4 + 12 + 2}{\sqrt{1 + 4 + 4}} \\ &= \frac{18}{\sqrt{9}} \\ &= \frac{18}{3} \\ &= 6 \end{aligned}$$

c. Same lengths and both are in the direction of \overline{OD} . Add to get one vector.

15. a. $1 = \cos^2 \alpha + \cos^2 \beta + \cos^2 \gamma$
 $= \left(\frac{a}{\sqrt{a^2 + b^2 + c^2}}\right)^2 + \left(\frac{b}{\sqrt{a^2 + b^2 + c^2}}\right)^2$
 $+ \left(\frac{c}{\sqrt{a^2 + b^2 + c^2}}\right)^2$
 $= \frac{a^2}{a^2 + b^2 + c^2} + \frac{b^2}{a^2 + b^2 + c^2}$
 $+ \frac{c^2}{a^2 + b^2 + c^2}$

$$= \frac{a^2 + b^2 + c^2}{a^2 + b^2 + c^2}$$

$$= 1$$

b. $\alpha = 90^\circ, \beta = 30^\circ, \gamma = 60^\circ$

$$\cos \alpha = \cos 90^\circ$$

$$= 0,$$

$$x = 0$$

$$\cos \beta = \cos 30^\circ$$

$$= \frac{\sqrt{3}}{2},$$

y is a multiple of $\frac{\sqrt{3}}{2}$.

$$\cos \gamma = \cos 60^\circ$$

$$= \frac{1}{2},$$

z is a multiple of $\frac{1}{2}$.

Answers include $(0, \frac{\sqrt{3}}{2}, \frac{1}{2}), (0, \sqrt{3}, 1)$, etc.

c. If two angles add to 90° , then all three will add to 180° .

16. a. $\alpha = \beta = \gamma$

$$\cos \alpha = \cos \beta = \cos \gamma$$

$$\cos^2 \alpha = \cos^2 \beta = \cos^2 \gamma$$

$$1 = \cos^2 \alpha + \cos^2 \beta + \cos^2 \gamma$$

$$1 = 3 \cos^2 x$$

$$\frac{1}{3} = \cos^2 x$$

$$\sqrt{\frac{1}{3}} = \cos x$$

$$x = \cos^{-1} \sqrt{\frac{1}{3}}$$

$$x \doteq 54.7^\circ$$

b. For obtuse, use $\cos x = -\sqrt{\frac{1}{3}}$.

$$x = \cos^{-1} \left(-\sqrt{\frac{1}{3}} \right)$$

$$x \doteq 125.3^\circ$$

17. $\cos^2 x + \sin^2 x = 1$

$$\cos^2 x = 1 - \sin^2 x$$

$$1 = \cos^2 \alpha + \cos^2 \beta + \cos^2 \gamma$$

$$1 = (1 - \sin^2 \alpha) + (1 - \sin^2 \beta) + (1 - \sin^2 \gamma)$$

$$1 = 3 - (\sin^2 \alpha + \sin^2 \beta + \sin^2 \gamma)$$

$$\sin^2 \alpha + \sin^2 \beta + \sin^2 \gamma = 2$$

18. Answers may vary. For example:

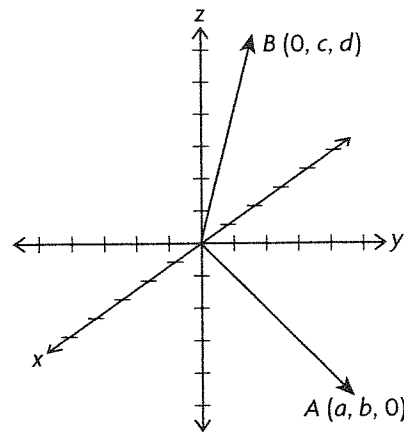

7.6 The Cross Product of Two Vectors, pp. 407–408

1. a.

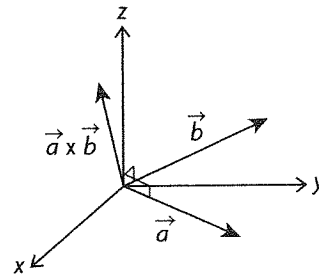

$\vec{a} \times \vec{b}$ is perpendicular to \vec{a} . Thus, their dot product must equal 0. The same applies to the second case.

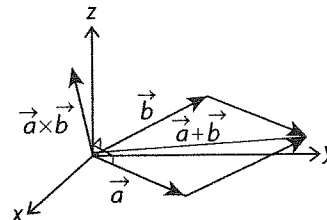

b. $\vec{a} + \vec{b}$ is still in the same plane formed by \vec{a} and \vec{b} , thus $\vec{a} + \vec{b}$ is perpendicular to $\vec{a} \times \vec{b}$ making the dot product 0 again.

c. Once again, $\vec{a} - \vec{b}$ is still in the same plane formed by \vec{a} and \vec{b} , thus $\vec{a} - \vec{b}$ is perpendicular to $\vec{a} \times \vec{b}$ making the dot product 0 again.

2. $\vec{a} \times \vec{b}$ produces a vector, not a scalar. Thus, the equality is meaningless.

3. a. It's possible because there is a vector crossed with a vector, then dotted with another vector, producing a scalar.

b. This is meaningless because $\vec{a} \cdot \vec{b}$ produces a scalar. This results in a scalar crossed with a vector, which is meaningless.

c. This is possible. $\vec{a} \times \vec{b}$ produces a vector, and $\vec{c} + \vec{d}$ also produces a vector. The result is a vector dotted with a vector producing a scalar.

d. This is possible. $\vec{a} \cdot \vec{b}$ produces a scalar, and $\vec{c} \times \vec{d}$ produces a vector. The product of a scalar and vector produces a vector.

e. This is possible. $\vec{a} \times \vec{b}$ produces a vector, and $\vec{c} \times \vec{d}$ produces a vector. The cross product of a vector and vector produces a vector.

f. This is possible. $\vec{a} \times \vec{b}$ produces a vector. When added to another vector, it produces another vector.

$$\begin{aligned} 4. \text{ a. } & (2, -3, 5) \times (0, -1, 4) \\ & = (-3(4) - 5(-1), 5(0) - 2(4), \\ & \quad 2(-1) - (-3)(0)) \\ & = (-7, -8, -2) \end{aligned}$$

$$\begin{aligned} (2, -3, 5) \cdot (-7, -8, -2) &= 0 \\ (0, -1, 4) \cdot (-7, -8, -2) &= 0 \end{aligned}$$

$$\begin{aligned} \text{b. } & (2, -1, 3) \times (3, -1, 2) \\ & = (-1(2) - 3(-1), 3(3) - 2(2), \\ & \quad 2(-1) - (-1)(3)) \\ & = (1, 5, 1) \end{aligned}$$

$$\begin{aligned} (2, -1, 3) \cdot (1, 5, 1) &= 0 \\ (3, -1, 2) \cdot (1, 5, 1) &= 0 \end{aligned}$$

$$\begin{aligned} \text{c. } & (5, -1, 1) \times (2, 4, 7) \\ & = (-1(7) - 1(4), 1(2) - 5(7), \\ & \quad 5(4) - (-1)(2)) \\ & = (-11, -33, 22) \end{aligned}$$

$$\begin{aligned} (5, -1, 1) \cdot (-11, -33, 22) &= 0 \\ (2, 4, 7) \cdot (-11, -33, 22) &= 0 \end{aligned}$$

$$\begin{aligned} \text{d. } & (1, 2, 9) \times (-2, 3, 4) \\ & = (2(4) - 9(3), 9(-2) - 1(4), \\ & \quad 1(3) - 2(-2)) \\ & = (-19, -22, 7) \end{aligned}$$

$$\begin{aligned} (1, 2, 9) \cdot (-19, -22, 7) &= 0 \\ (-2, 3, 4) \cdot (-19, -22, 7) &= 0 \end{aligned}$$

$$\begin{aligned} \text{e. } & (-2, 3, 3) \times (1, -1, 0) \\ & = (3(0) - 3(-1), 3(1) - (-2)(0), \\ & \quad -2(-1) - 3(1)) \\ & = (3, 3, -1) \end{aligned}$$

$$\begin{aligned} (-2, 3, 3) \cdot (3, 3, -1) &= 0 \\ (1, -1, 0) \cdot (3, 3, -1) &= 0 \end{aligned}$$

$$\begin{aligned} \text{f. } & (5, 1, 6) \times (-1, 2, 4) \\ & = (1(4) - 6(2), 6(-1) - 5(4), \\ & \quad 5(2) - 1(-1)) \\ & = (-8, -26, 11) \end{aligned}$$

$$\begin{aligned} (5, 1, 6) \cdot (-8, -26, 11) &= 0 \\ (-1, 2, 4) \cdot (-8, -26, 11) &= 0 \end{aligned}$$

$$\begin{aligned} 5. & (-1, 3, 5) \times (0, a, 1) \\ & = (3(1) - 5(a), 5(0) - (-1)(1), \\ & \quad -1(a) - 3(0)) \end{aligned}$$

If we look at the x component, we know that:

$$3(1) - 5(a) = -2$$

$$-5(a) = -5$$

$$a = 1$$

$$\begin{aligned} 6. \text{ a. } \vec{a} \times \vec{b} &= (1(1) - 1(5), 1(0) - 0(1), \\ & \quad 0(5) - 0(1)) \\ &= (-4, 0, 0) \end{aligned}$$

b. Vectors of the form $(0, b, c)$ are in the yz -plane. Thus, the only vectors perpendicular to the yz -plane are those of the form $(a, 0, 0)$ because they are parallel to the x -axis.

$$\begin{aligned} 7. \text{ a. } & (1, 2, 1) \times (2, 4, 2) \\ & = (2(2) - 1(4), 1(2) - 1(2), 1(4) - 2(2)) \\ & = (0, 0, 0) \end{aligned}$$

$$\begin{aligned} \text{b. } & (a, b, c) \times (ka, kb, kc) \\ & = (b(kc) - c(kb), c(ka) - a(kc), \\ & \quad a(kb) - b(ka)) \end{aligned}$$

Using the commutative law of multiplication we can rearrange this:

$$\begin{aligned} &= (bck - bck, ack - ack, abk - abk) \\ &= (0, 0, 0) \end{aligned}$$

$$\begin{aligned} 8. \text{ a. } \vec{p} \times (\vec{q} + \vec{r}) &= (1, -2, 4) \times [(1, 2, 7) \\ & \quad + (-1, 1, 0)] \\ &= (1, -2, 4) \times (1 - 1, 2 + 1, 7 + 0) \\ &= (1, -2, 4) \times (0, 3, 7) \\ &= (-2(7) - 4(3), 4(0) - 1(7), \\ & \quad 1(3) + 2(0)) \\ &= (-26, -7, 3) \end{aligned}$$

$$\begin{aligned} \vec{p} \times \vec{q} + \vec{p} \times \vec{r} &= (-2(7) - 4(2), \\ & \quad 4(1) - 1(7), 1(2) + 2(1)) \\ & \quad + (-2(0) - 4(1), \\ & \quad 4(-1) - 1(0), 1(1) + 2(-1)) \\ &= (-22, -3, 4) + (-4, -4, -1) \\ &= (-26, -7, 3) \end{aligned}$$

$$\begin{aligned} \text{b. } \vec{p} \times (\vec{q} + \vec{r}) &= (4, 1, 2) \times [(3, 1, -1) \\ & \quad + (0, 1, 2)] \\ &= (4, 1, 2) \times (3, 1 + 1, -1 + 2) \\ &= (4, 1, 2) \times (3, 2, 1) \\ &= (1(1) - 2(2), 3(2) - 4(1), \\ & \quad 4(2) - 1(3)) \\ &= (-3, 2, 5) \end{aligned}$$

$$\begin{aligned} \vec{p} \times \vec{q} + \vec{p} \times \vec{r} &= (1(-1) - 2(1), 2(3) - 4(-1), \\ & \quad 4(1) - 1(3)) + (1(2) - 2(1), \\ & \quad 2(0) - 4(2), 4(1) - 1(0)) \\ &= (-3, 10, 1) + (0, -8, 4) \\ &= (-3, 2, 5) \end{aligned}$$

$$\begin{aligned} 9. \text{ a. } \vec{i} \times \vec{j} &= (1, 0, 0) \times (0, 1, 0) \\ &= (0 - 0, 0 - 0, 1 - 0) \\ &= (0, 0, 1) \\ &= \vec{k} \end{aligned}$$

$$\begin{aligned} -\vec{j} \times \vec{i} &= (0, -1, 0) \times (1, 0, 0) \\ &= (0 - 0, 0 - 0, 0 - (-1)) \\ &= (0, 0, 1) \\ &= \vec{k} \end{aligned}$$

$$\begin{aligned} \text{b. } \vec{j} \times \vec{k} &= (0, 1, 0) \times (0, 0, 1) \\ &= (1 - 0, 0 - 0, 0 - 0) \\ &= (1, 0, 0) \\ &= \vec{i} \end{aligned}$$

$$\begin{aligned} -\vec{k} \times \vec{j} &= (0, 0, -1) \times (0, 1, 0) \\ &= (0 - (-1), 0 - 0, 0 - 0) \\ &= (1, 0, 0) \\ &= \vec{i} \end{aligned}$$

$$\begin{aligned} \text{c. } \vec{k} \times \vec{i} &= (0, 0, 1) \times (1, 0, 0) \\ &= (0 - 0, 1 - 0, 0 - 0) \\ &= (0, 1, 0) \\ &= \vec{j} \end{aligned}$$

$$\begin{aligned} -\vec{i} \times \vec{k} &= (-1, 0, 0) \times (0, 0, 1) \\ &= (0 - 0, 0 - (-1), 0 - 0) \\ &= (0, 1, 0) \\ &= \vec{j} \end{aligned}$$

$$\begin{aligned} \text{10. } k(a_2b_3 - a_3b_2, a_3b_1 - a_1b_3, a_1b_2 - a_2b_1) \\ \cdot (a_1, a_2, a_3) \\ &= k(a_1a_2b_3 - a_1a_3b_2 + a_2a_3b_1 - a_2a_1b_3 \\ &\quad + a_3a_1b_2 - a_3a_2b_1) \\ &= k(0) \\ &= 0 \end{aligned}$$

\vec{a} is perpendicular to $k(\vec{a} \times \vec{b})$.

$$\begin{aligned} \text{11. a. } \vec{a} \times \vec{b} &= (2, 0, 0) \times (0, 3, 0) \\ &= (0 - 0, 0 - 0, 6 - 0) \\ &= (0, 0, 6) \end{aligned}$$

$$\begin{aligned} \vec{c} \times \vec{d} &= (2, 3, 0) \times (4, 3, 0) \\ &= (0 - 0, 0 - 0, 6 - 12) \\ &= (0, 0, -6) \end{aligned}$$

$$\begin{aligned} \text{b. } (\vec{a} \times \vec{b}) \times (\vec{c} \times \vec{d}) &= (0, 0, 6) \times (0, 0, -6) \\ \text{(by part a.)} \\ &= (0 - 0, 0 - 0, 0 - 0) \\ &= (0, 0, 0) \end{aligned}$$

c. All the vectors are in the xy -plane. Thus, the cross product in part b. is between vectors parallel to the z -axis and so parallel to each other. The cross product of parallel vectors is $\vec{0}$.

$$\begin{aligned} \text{12. Let } \vec{x} &= (1, 0, 1) \\ \vec{y} &= (1, 1, 1) \\ \vec{z} &= (1, 2, 3) \end{aligned}$$

$$\begin{aligned} \text{Then } \vec{x} \times \vec{y} &= (0 - 1, 1 - 1, 1 - 0) \\ &= (-1, 0, 1) \end{aligned}$$

$$\begin{aligned} (\vec{x} \times \vec{y}) \times \vec{z} &= (0 - 2, 1 - (-3), -3 - 0) \\ &= (-2, 4, -3) \end{aligned}$$

$$\begin{aligned} \vec{y} \times \vec{z} &= (3 - 2, 1 - 3, 2 - 1) \\ &= (1, -2, 1) \end{aligned}$$

$$\begin{aligned} \vec{x} \times (\vec{y} \times \vec{z}) &= (0 + 2, 1 - 1, -2 - 0) \\ &= (2, 0, -2) \end{aligned}$$

Thus $(\vec{x} \times \vec{y}) \times \vec{z} \neq \vec{x} \times (\vec{y} \times \vec{z})$.

$$\text{13. } (\vec{a} - \vec{b}) \times (\vec{a} + \vec{b})$$

By the distributive property of cross product:

$$= (\vec{a} - \vec{b}) \times \vec{a} + (\vec{a} - \vec{b}) \times \vec{b}$$

By the distributive property again:

$$= \vec{a} \times \vec{a} - \vec{b} \times \vec{a} + \vec{a} \times \vec{b} - \vec{b} \times \vec{b}$$

A vector crossed with itself equals $\vec{0}$, thus:

$$= -\vec{b} \times \vec{a} + \vec{a} \times \vec{b}$$

$$= \vec{a} \times \vec{b} - \vec{b} \times \vec{a}$$

$$= \vec{a} \times \vec{b} - (-\vec{a} \times \vec{b})$$

$$= 2\vec{a} \times \vec{b}$$

7.7 Applications of the Dot Product and Cross Product, pp. 414–415

1. By pushing as far away from the hinge as possible, $|\vec{r}|$ is increased making the cross product bigger. By pushing at right angles, sine is its largest value, 1, making the cross product larger.

$$\begin{aligned} \text{2. a. } \vec{a} \times \vec{b} &= (1, 2, 1) \times (2, 4, 2) \\ &= (2(2) - 1(4), 1(2) \\ &\quad - 1(2), 1(4) - 2(2)) \\ &= (0, 0, 0) \end{aligned}$$

$$|\vec{a} \times \vec{b}| = 0$$

b. This makes sense because the vectors lie on the same line. Thus, the parallelogram would just be a line making its area 0.

$$\text{3. a. } \vec{f} \cdot \vec{s} = 3 \cdot 150 = 450 \text{ J}$$

b.

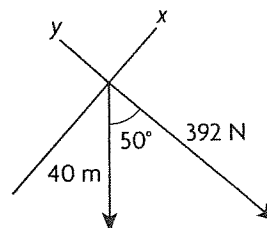

The axes are tilted to illustrate the force of gravity can be split up into components to find the part in the direction of the motion. Let x be the component of force going in the motion's direction.

$$\cos(50^\circ) = \frac{x}{392}$$

$$x = (392) \cos(50^\circ)$$

Now we have our force, so:

$$(392) \cos 50^\circ \text{ N} \cdot 40 \text{ m} \approx 10\,078.91 \text{ J}$$

c.

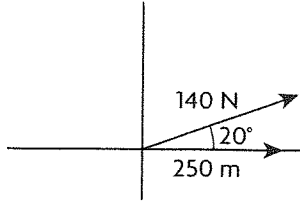

First find the x component of the force:

$$(140)\cos(20^\circ) = x$$

Calculate work:

$$140 \cos 20^\circ \text{ N} \cdot 250 \text{ m} \doteq 32\,889.24 \text{ J}$$

d.

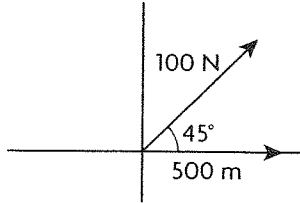

First calculate the x component of the force:

$$x = (100)\cos(45^\circ)$$

Calculate work:

$$100 \cos 45^\circ \cdot 500 \text{ m} = 35\,355.34 \text{ J}$$

4. a. $\vec{i} \times \vec{j} = \vec{k}$

The square formed by the 2 vectors has an area of 1. The 2 vectors are on the xy -plane, thus, the cross product must be \vec{k} by the right hand rule.

b. $-\vec{i} \times \vec{j} = -\vec{k}$

Once again, the area is 1, making the possible vector have a magnitude of 1. Also, the 2 vectors are on the xy -plane again so the cross product must lie on the z axis. However, because of the right hand rule, the product must be $-\vec{k}$ this time.

c. $\vec{i} \times \vec{k} = -\vec{j}$

The square has an area of 1, so the magnitude of the vector produced must be 1. The 2 vectors are on the xz -plane. The new vector must be on the y axis making it $-\vec{j}$ because of the right hand rule.

d. $-\vec{i} \times \vec{k} = -\vec{j}$

The square has an area of 1. The 2 vectors are on the xz -plane. So the new vector must be \vec{j} because of the right hand rule.

5. a. $\vec{a} \times \vec{b} = (1, 1, 0) \times (1, 0, 1)$
 $= (1 - 0, 0 - 1, 0 - 1)$
 $= (1, -1, -1)$

$$|\vec{a} \times \vec{b}| = \sqrt{1 + 1 + 1} = \sqrt{3}$$

So the area of the parallelogram is $\sqrt{3}$ square units.

b. $\vec{a} \times \vec{b} = (1, -2, 3) \times (1, 2, 4)$
 $= (-8 - 6, 3 - 4, 2 + 2)$
 $= (-14, -1, 4)$

$$|\vec{a} \times \vec{b}| = \sqrt{196 + 1 + 16} = \sqrt{213}$$

So the area of the parallelogram is $\sqrt{213}$ square units.

6. $\vec{p} \times \vec{q} = (a, 1, -1) \times (1, 1, 2)$
 $= (2 + 1, -2a - 1, a - 1)$
 $= (3, 2a + 1, a - 1)$

$$|\vec{p} \times \vec{q}| = \sqrt{9 + (2a + 1)^2 + (a - 1)^2} = \sqrt{35}$$

$$9 + (2a + 1)^2 + (a - 1)^2 = 35$$

$$9 + 4a^2 + 4a + 1 + a^2 - 2a + 1 = 35$$

$$5a^2 + 2a - 24 = 0$$

$$a = \frac{-2 \pm \sqrt{2^2 - 4(5)(-24)}}{2(5)}$$

$$= \frac{-2 \pm 22}{10}$$

$$= 2, \frac{-12}{5}$$

7. a.

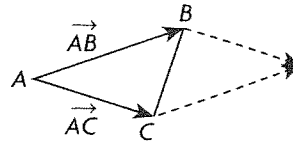

As we see from the picture, the area of the triangle ABC is just half the area of the parallelogram determined by vectors \vec{AB} and \vec{AC} . Thus, we use the magnitude of the cross product to calculate the area.

$$\vec{AB} = (1 + 2, 0 - 1, 1 - 3) = (3, -1, -2)$$

$$\vec{AC} = (2 + 2, 3 - 1, 2 - 3) = (4, 2, -1)$$

$$\vec{AB} \times \vec{AC} = (1 + 4, -3 + 8, 6 + 4) = (5, 5, 10)$$

$$|\vec{AB} \times \vec{AC}| = \sqrt{25 + 25 + 100} = 5\sqrt{6}$$

Since triangle ABC is half the area of the parallelogram, its area is $\frac{5\sqrt{6}}{2}$ square units.

b. This is just a different way of describing the first triangle, thus the area is $\frac{5\sqrt{6}}{2}$ square units.

c. Any two sides of a triangle can be used to calculate its area.

8. $|\vec{r} \times \vec{f}| = (|\vec{r}|\sin(\theta))|\vec{f}|$
 $= (0.14)\sin(45^\circ) \cdot 10$
 $\doteq 0.99 \text{ J}$

9.

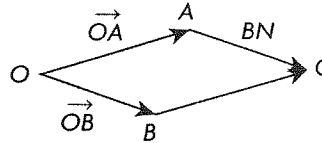

We know that the area of a parallelogram is equal to its height multiplied with its base. Its height is BN and its base is $\vec{AC} = \vec{OB}$ as can be seen from the picture. We can calculate the area using the given vectors, then use the area to find BN .

$$\vec{OA} \times \vec{OB} = (8 - 4, 12 - 16, 4 - 6)$$

$$= (4, -4, -2)$$

$$|\vec{OA} \times \vec{OB}| = \sqrt{16 + 16 + 4} = \sqrt{36} = 6$$

Now we need to calculate $|\overline{OB}|$ to know the length of the base.

$$\overline{AC} = |\overline{OB}| = \sqrt{9 + 1 + 16} = \sqrt{26}$$

Substituting these results into the equation for area:

$$|\overline{OB}| \cdot BN = 6$$

$$\sqrt{26} BN = 6$$

$$BN = \frac{6}{\sqrt{26}} \text{ or about } 1.18$$

$$10. \text{ a. } \vec{p} \times \vec{q} = (-6 - 3, 6 - 3, 1 + 4) = (-9, 3, 5)$$

$$(\vec{p} \times \vec{q}) \times \vec{r} = (0 - 5, 5 + 0, -9 - 3) = (-5, 5, -12)$$

$$a(1, -2, 3) + b(2, 1, 3) = (-5, 5, -12)$$

Looking at x components:

$$a + 2b = -5; a = -5 - 2b$$

y components:

$$-2a + b = 5$$

Substitute in a:

$$10 + 4b + b = 5$$

$$5b = -5$$

$$b = -1$$

Substitute b back into the x components:

$$a = -5 + 2; a = -3$$

Check in z components:

$$3a + 3b = -12$$

$$-9 - 3 = -12$$

$$\text{b. } \vec{p} \cdot \vec{r} = 1 - 2 + 0 = -1$$

$$\vec{q} \cdot \vec{r} = 2 + 1 + 0 = 3$$

$$\begin{aligned} (\vec{p} \cdot \vec{r})\vec{q} - (\vec{q} \cdot \vec{r})\vec{p} &= -1(2, 1, 3) - 3(1, -2, 3) \\ &= (2, -1, -3) - (3, -6, 9) \\ &= (-2 - 3, -1 + 6, -3 - 9) \\ &= (-5, 5, -12) \end{aligned}$$

Review Exercise, pp. 418–421

$$1. \text{ a. } \vec{a} \times \vec{b} = (2 - 0, -1 + 1, 0 + 2) = (2, 0, 2)$$

$$\text{b. } \vec{b} \times \vec{c} = (0 - 4, -5 + 5, -4 - 0) = (-4, 0, -4)$$

c. 16

d. The cross products are parallel, so the original vectors are in the same plane.

$$2. \text{ a. } |\vec{a}| = \sqrt{2^2 + (-1)^2 + 2^2} = 3$$

$$\text{b. } |\vec{b}| = \sqrt{6^2 + 3^2 + (-2)^2} = 7$$

$$\text{c. } \vec{a} - \vec{b} = (2 - 6, -1 - 3, 2 + 2) = (-4, -4, 4)$$

$$|\vec{a} - \vec{b}| = \sqrt{(-4)^2 + (-4)^2 + 4^2} = 4\sqrt{3}$$

$$\text{d. } \vec{a} + \vec{b} = (2 + 6, -1 + 3, 2 - 2) = (8, 2, 0)$$

$$|\vec{a} + \vec{b}| = \sqrt{8^2 + 2^2 + 0^2} = 2\sqrt{17}$$

$$\text{e. } \vec{a} \cdot \vec{b} = 2(6) - 1(3) + 2(-2) = 5$$

$$\text{f. } \vec{a} - 2\vec{b} = (2 - 12, -1 - 6, 2 + 4) = (-10, -7, 6)$$

$$\vec{a} \cdot (\vec{a} - 2\vec{b}) = 2(-10) - 1(-7) + 2(6) = -1$$

3. a. If $a = 6$, then \vec{y} will be twice \vec{x} , thus collinear.

$$\text{b. } \vec{x} \times \vec{y} = (3, a, 9) \cdot (a, 12, 18) = 0$$

$$3a + 12a + 162 = 0$$

$$15a = -162$$

$$a = \frac{-54}{5}$$

$$4. \cos(\theta) = \frac{\vec{a} \cdot \vec{b}}{|\vec{a}||\vec{b}|}$$

$$\vec{a} \cdot \vec{b} = 4(-3) + 5(6) + 20(22) = 458$$

$$|\vec{a}| = \sqrt{4^2 + 5^2 + 20^2} = 21$$

$$|\vec{b}| = \sqrt{(-3)^2 + 6^2 + 22^2} = 23$$

$$\theta = \cos^{-1}\left(\frac{458}{483}\right)$$

$$\theta \doteq 18.52^\circ$$

5. a.

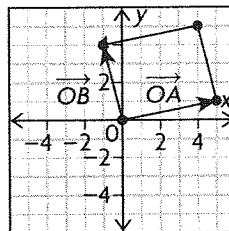

b. We can use the dot product of the 2 diagonals to calculate the angle. The diagonals are the vectors $\overline{OA} + \overline{OB}$ and $\overline{OA} - \overline{OB}$.

$$\overline{OA} + \overline{OB} = (5 - 1, 1 + 4) = (4, 5)$$

$$\overline{OA} - \overline{OB} = (5 + 1, 1 - 4) = (6, -3)$$

$$\cos(\theta) = \frac{(\overline{OA} + \overline{OB}) \cdot (\overline{OA} - \overline{OB})}{|\overline{OA} + \overline{OB}||\overline{OA} - \overline{OB}|}$$

$$(\overline{OA} + \overline{OB}) \cdot (\overline{OA} - \overline{OB}) = 4(6) + 5(-3) = 9$$

$$|\overline{OA} + \overline{OB}| = \sqrt{4^2 + 5^2} = \sqrt{41}$$

$$|\overline{OA} - \overline{OB}| = \sqrt{6^2 + (-3)^2} = 3\sqrt{5}$$

$$\theta = \cos^{-1}\left(\frac{9}{3\sqrt{205}}\right)$$

$$\theta \doteq 77.9^\circ$$

6.

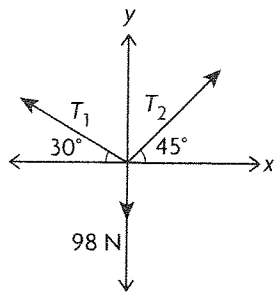

The vertical components of the tensions must equal the downward force:

$$T_1 \sin(30^\circ) + T_2 \sin(45^\circ) = 98 \text{ N}$$

$$\frac{1}{2}T_1 + \frac{1}{\sqrt{2}}T_2 = 98$$

$$T_1 = 196 - \sqrt{2}T_2$$

The horizontal components:

$$T_1 \cos(30^\circ) + T_2 \cos(45^\circ) = 0 \text{ N}$$

$$\frac{\sqrt{3}}{2}T_1 - \frac{1}{\sqrt{2}}T_2 = 0$$

Substitute in T_1 :

$$98\sqrt{3} - \frac{\sqrt{6}}{2}T_2 = -98\sqrt{3}$$

$$\frac{-\sqrt{6} - \sqrt{2}}{2}T_2 = -98\sqrt{3}$$

$$T_2 \approx 87.86 \text{ N}$$

Substitute this back in to get T_1 :

$$T_1 \approx 71.74 \text{ N}$$

7.

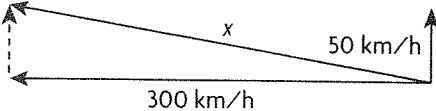

$$x = \sqrt{50^2 + 300^2} \approx 304.14$$

$$\tan^{-1}\left(\frac{50}{300}\right) \approx 9.46^\circ$$

The resultant velocity is 304.14 km/h, W 9.46° N.

8. a.

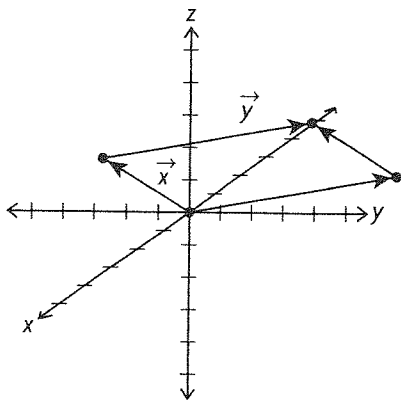

$$\begin{aligned} \mathbf{b.} \quad \vec{x} \times \vec{y} &= (-15 - 35, -5 - 15, 21 - 3) \\ &= (-50, -20, 18) \end{aligned}$$

$$|\vec{x} \times \vec{y}| = \sqrt{50^2 + 20^2 + 18^2} = \sqrt{3224} \approx 56.78$$

$$9. (0, 3, -5) \times (2, 3, 1)$$

$$= (3 + 15, -10 - 0, 0 - 6) = (18, -10, -6)$$

The cross product is perpendicular to the given vectors, but its magnitude is

$\sqrt{18^2 + (-10)^2 + (-6)^2}$, or $2\sqrt{115}$. A unit vector perpendicular to the given vectors is

$$\left(\frac{9}{\sqrt{115}}, -\frac{5}{\sqrt{115}}, -\frac{3}{\sqrt{115}}\right).$$

$$10. \mathbf{a.} \cos(\alpha) = \frac{\overline{AB} \cdot \overline{AC}}{|\overline{AB}| |\overline{AC}|}$$

$$\overline{AB} = (0, -3, 4) - (2, 3, 7) = (-2, -6, -3)$$

$$\overline{AC} = (5, 2, -4) - (2, 3, 7) = (3, -1, -11)$$

$$\overline{AB} \cdot \overline{AC} = -2(3) - 6(-1) - 3(-11) = 33$$

$$|\overline{AB}| = \sqrt{(-2)^2 + (-6)^2 + (-3)^2} = 7$$

$$|\overline{AC}| = \sqrt{3^2 + (-1)^2 + (-11)^2} = \sqrt{131}$$

$$\alpha = \cos^{-1} \frac{\overline{AB} \cdot \overline{AC}}{|\overline{AB}| |\overline{AC}|}$$

$$= \cos^{-1} \frac{33}{7\sqrt{131}}$$

$$\approx 65.68^\circ$$

$$\beta = \cos^{-1} \frac{\overline{BA} \cdot \overline{BC}}{|\overline{BA}| |\overline{BC}|}$$

$$\overline{BA} = -\overline{AB} = (2, 6, 3)$$

$$\overline{BC} = (5 - 0, 2 + 3, -4 - 4) = (5, 5, -8)$$

$$\overline{BA} \cdot \overline{BC} = 2(5) + 6(5) + 3(-8) = 16$$

$$|\overline{BA}| = \sqrt{2^2 + 6^2 + 3^2} = 7$$

$$|\overline{BC}| = \sqrt{5^2 + 5^2 + (-8)^2} = \sqrt{144}$$

$$\beta = \cos^{-1} \frac{16}{7\sqrt{144}}$$

$$\approx 77.64^\circ$$

$$\gamma = 180 - \alpha - \beta \approx 36.68^\circ$$

So $\beta \approx 77.64^\circ$ is the largest angle.

b. The area is half the magnitude of the cross product of \overline{AB} and \overline{AC} .

$$\frac{1}{2} \overline{AB} \times \overline{AC} = \frac{1}{2} |(63, -31, 20)| \approx 36.50$$

11. The triangle formed by the two strings and the ceiling is similar to a 3-4-5 right triangle, with the 30 cm and 40 cm strings as legs. So the angle adjacent to the 30 cm leg satisfies

$$\cos \theta = \frac{3}{5}$$

The angle adjacent to the 40 cm leg satisfies

$$\cos \phi = \frac{4}{5}$$

Also,

$$\sin \theta = \frac{4}{5} \text{ and } \sin \phi = \frac{3}{5}.$$

Let T_1 be the tension in the 30 cm string, and T_2 be the tension in the 40 cm string. Then

$$T_1 \cos \theta - T_2 \cos \phi = 0$$

$$T_1 \frac{3}{5} - T_2 \frac{4}{5} = 0$$

$$T_1 = \frac{4}{3} T_2$$

Also,

$$T_1 \sin \theta + T_2 \sin \phi = (10)(9.8) = 98$$

$$T_1 \frac{4}{5} - T_2 \frac{3}{5} = 98$$

$$\left(\frac{4}{3} T_2\right) \frac{4}{5} + T_2 \frac{3}{5} = 98$$

$$\frac{5}{3} T_2 = 98$$

$$T_2 = 58.8 \text{ N}$$

$$T_1 = \frac{4}{3}(58.8)$$

$$= 78.4 \text{ N}$$

So the tension in the 30 cm string is 78.4 N and the tension in the 40 cm string is 58.8 N.

12. a.

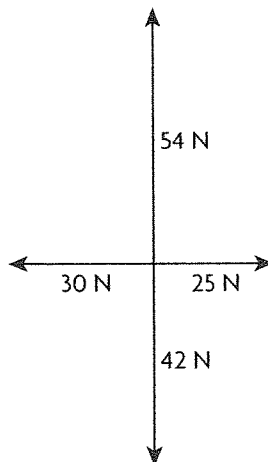

b. The east- and west-pulling forces result in a force of 5 N west. The north- and south-pulling forces result in a force of 12 N north. The 5 N west and 12 N north forces result in a force pulling in the north-westerly direction with a force of

$$\sqrt{5^2 + 12^2} = 13 \text{ N,}$$

by using the Pythagorean theorem. To find the exact direction of this force, use the definition of sine.

If θ is the angle west of north, then

$$\sin \theta = \frac{5}{13}$$

$$\theta \doteq 22.6^\circ$$

So the resultant is 13 N in a direction

N22.6°W. The equilibrant is 13 N in a direction S22.6°E.

13. a. Let D be the origin, then:

$$A = (2, 0, 0), B = (2, 4, 0), C = (0, 4, 0),$$

$$D = (0, 0, 0), E = (2, 0, 3), F = (2, 4, 3),$$

$$G = (0, 4, 3) H = (0, 0, 3)$$

b. $\overrightarrow{AF} = (0, 4, 3)$

$$\overrightarrow{AC} = (-2, 4, 0)$$

$$\overrightarrow{AF} \cdot \overrightarrow{AC} = 0 + 16 + 0 = 16$$

$$|\overrightarrow{AF}| = \sqrt{0^2 + 4^2 + 3^2} = 5$$

$$|\overrightarrow{AC}| = \sqrt{(-2)^2 + 4^2 + 0^2} = 2\sqrt{5}$$

$$\cos(\theta) = \frac{\overrightarrow{AF} \cdot \overrightarrow{AC}}{|\overrightarrow{AF}| |\overrightarrow{AC}|}$$

$$\theta = \cos^{-1}\left(\frac{16}{10\sqrt{5}}\right)$$

$$\theta \doteq 44.31^\circ$$

c. Scalar projection = $|\overrightarrow{AF}| \cos(\theta)$

By part b.:

$$= (5) \cos(44.31^\circ)$$

$$\doteq 3.58$$

14. $\vec{a} \cdot \vec{b} = |\vec{a}| |\vec{b}| \cos(\theta) = \cos(\theta)$

$$\cos(\theta) = -\frac{1}{2} \text{ (cosine law)}$$

$$(2\vec{a} - 5\vec{b}) \cdot (\vec{b} + 3\vec{a})$$

$$= -13\vec{a} \cdot \vec{b} + 6\vec{a} \cdot \vec{a} - 5\vec{b} \cdot \vec{b}$$

$$= -13\vec{a} \cdot \vec{b} + 1$$

$$= -13 \cos(\theta) + 1$$

$$= 7.5$$

15. a. The angle to the bank, θ , will satisfy

$$\sin(90^\circ - \theta) = \frac{2}{3}$$

$$90^\circ - \theta \doteq 41.8^\circ$$

$$\theta \doteq 48.2^\circ$$

b. By the Pythagorean theorem, Kayla's net swimming speed will be

$$\sqrt{3^2 - 2^2} = \sqrt{5} \text{ km/h.}$$

So since distance = rate \times time, it will take her

$$t = \frac{0.3}{\sqrt{5}}$$

$$\doteq 0.13 \text{ h}$$

$$\doteq 8 \text{ min } 3 \text{ sec}$$

to swim across.

c. Such a situation would have resulted in a right triangle where one of the legs is longer than the hypotenuse, which is impossible.

16. a. The diagonals are $\overrightarrow{OA} + \overrightarrow{OB}$ and $\overrightarrow{OA} - \overrightarrow{OB}$.

$$\overrightarrow{OA} + \overrightarrow{OB} = (3 - 6, 2 + 6, -6 - 2) = (-3, 8, -8)$$

$$\overrightarrow{OA} - \overrightarrow{OB} = (3 + 6, 2 - 6, -6 + 2) = (9, -4, -4)$$

b. $\overrightarrow{OA} \cdot \overrightarrow{OB} = 3(-6) + 2(6) - 6(-2) = 6$

$$|\overrightarrow{OA}| = \sqrt{3^2 + 2^2 + (-6)^2} = 7$$

$$|\overrightarrow{OB}| = \sqrt{(-6)^2 + 6^2 + (-2)^2} = 2\sqrt{19}$$

$$\cos(\theta) = \frac{\overrightarrow{OA} \cdot \overrightarrow{OB}}{|\overrightarrow{OA}| |\overrightarrow{OB}|}$$

$$\theta = \cos^{-1} \left(\frac{6}{14\sqrt{19}} \right)$$

$$\doteq 84.36^\circ$$

17. a. The z value is double, so if $a = 4$ and $b = -4$, the vector \vec{q} will be collinear.

b. If \vec{p} and \vec{q} are perpendicular, then their dot product will equal 0.

$$\vec{p} \cdot \vec{q} = 2a - 2b - 18 = 0$$

c. Let $a = 9$, and $b = 0$, then we have a vector perpendicular to \vec{p} . Now it must be divided by its magnitude to make it a unit vector:

$$|\vec{p}| = \sqrt{81 + 0 + 324} = 9\sqrt{5}$$

So the unit vector is:

$$\left(\frac{1}{\sqrt{5}}, 0, \frac{2}{\sqrt{5}} \right)$$

18. a. $\vec{m} \cdot \vec{n} = 2\sqrt{3} - 2\sqrt{3} + 3 = 3$

$$|\vec{m}| = \sqrt{3 + 4 + 9} = 4$$

$$|\vec{n}| = \sqrt{4 + 3 + 1} = 2\sqrt{2}$$

$$\cos(\theta) = \frac{\vec{m} \cdot \vec{n}}{|\vec{m}| |\vec{n}|}$$

$$\theta = \cos^{-1} \left(\frac{3}{8\sqrt{2}} \right)$$

$$\doteq 74.62^\circ$$

b. Scalar projection = $|\vec{n}| \cos(\theta)$

$$= 2\sqrt{2} \cos(74.62^\circ)$$

$$\doteq 0.75$$

c. Scalar projection multiplied with the unit vector in the direction of \vec{m} :

$$= (0.75) \frac{\vec{m}}{|\vec{m}|}$$

$$= (0.75) \frac{(\sqrt{3}, -2, -3)}{4}$$

$$= (0.1875)(\sqrt{3}, -2, -3)$$

d. $\vec{m} \cdot \vec{k} = -3$

$$\theta = \cos^{-1} \left(\frac{-3}{4} \right)$$

$$\doteq 138.59^\circ$$

19. a. If the dot product is 0, then the vectors are perpendicular:

$$(1, 0, 0) \cdot (0, 0, -1) = 0 + 0 + 0 = 0$$

$$(1, 0, 0) \cdot (0, 1, 0) = 0 + 0 + 0 = 0$$

$$(0, 0, -1) \cdot (0, 1, 0) = 0 + 0 + 0 = 0 \text{ special}$$

b. $\left(\frac{1}{\sqrt{2}}, \frac{1}{\sqrt{2}}, 0 \right) \cdot \left(\frac{-1}{\sqrt{3}}, \frac{1}{\sqrt{3}}, \frac{1}{\sqrt{3}} \right)$

$$= -\frac{1}{\sqrt{6}} + \frac{1}{\sqrt{6}} + 0$$

$$= 0$$

$$\left(\frac{1}{\sqrt{2}}, \frac{1}{\sqrt{2}}, 0 \right) \cdot (0, 0, -1) = 0 + 0 + 0 = 0$$

$$\left(\frac{-1}{\sqrt{3}}, \frac{1}{\sqrt{3}}, \frac{1}{\sqrt{3}} \right) \cdot (0, 0, -1)$$

$$= 0 + 0 + -\frac{1}{\sqrt{3}} = -\frac{1}{\sqrt{3}} \text{ not special}$$

20. a. $\vec{p} \times \vec{q}$

$$= (-2(1) - 1(-1), 1(2) - 1(1), 1(-1) + 2(2))$$

$$= (-1, 1, 3)$$

b. $\vec{p} - \vec{q} = (-1, -1, 0)$

$$\vec{p} + \vec{q} = (3, -3, 2)$$

$$(\vec{p} - \vec{q}) \times (\vec{p} + \vec{q}) = (-2 - 0, 0 + 2, 3 - (-3)) = (-2, 2, 6)$$

c. $\vec{p} \times \vec{r} = (4 - 1, 0 + 2, 1 - 0)$

$$= (3, 2, 1)$$

$$(\vec{p} \times \vec{r}) \cdot \vec{r} = 0 + 2 - 2 = 0$$

d. $\vec{p} \times \vec{q} = (-2 + 1, 2 - 1, -1 + 4)$

$$= (-1, 1, 3)$$

21. Since the angle between the two vectors is 60° , the angle formed when they are placed head-to-tail is 120° . So the resultant, along with these two vectors, forms an isosceles triangle with top angle 120° and two equal angles 30° . By the cosine law, the two equal forces satisfy

$$20^2 = 2F^2 - 2F^2 \cos 120^\circ$$

$$F^2 = \frac{400}{3}$$

$$F = \frac{20}{\sqrt{3}}$$

$$\doteq 11.55 \text{ N}$$

22. $\vec{a} \times \vec{b} = (2 - 0, -5 - 3, 0 - 10)$

$$= (2, -8, -10)$$

23. First we need to determine the dot product of \vec{x} and \vec{y} :

$$\begin{aligned}\vec{x} \cdot \vec{y} &= |\vec{x}||\vec{y}|\cos\theta \\ &= (10)\cos(60^\circ) \\ &= 5\end{aligned}$$

$$(\vec{x} - 2\vec{y}) \cdot (\vec{x} + 3\vec{y})$$

By the distributive property:

$$\begin{aligned}&= \vec{x} \cdot \vec{x} + 3\vec{x} \cdot \vec{y} - 2\vec{x} \cdot \vec{y} - 6\vec{y} \cdot \vec{y} \\ &= 4 + 15 - 10 - 150 \\ &= -141\end{aligned}$$

24. $|(2, 2, 1)| = \sqrt{2^2 + 2^2 + 1^2} = 3$

Since the magnitude of the scalar projection is 4, the scalar projection itself has value 4 or -4 .

If it is 4, we get

$$\frac{(1, m, 0) \cdot (2, 2, 1)}{3} = 4$$

$$2 + 2m = 12$$

$$m = 5$$

If it is -4 , we get

$$\frac{(1, m, 0) \cdot (2, 2, 1)}{3} = -4$$

$$2 + 2m = -12$$

$$m = -7$$

So the two possible values for m are 5 and -7 .

25. $\vec{a} \cdot \vec{j} = -3$

$$|\vec{a}| = \sqrt{144 + 9 + 16} = 13$$

$$\begin{aligned}\theta &= \cos^{-1}\left(\frac{-3}{13}\right) \\ &\doteq 103.34^\circ\end{aligned}$$

26. a. $C = (3, 0, 5)$, $F = (0, 4, 0)$

b. $\overrightarrow{CF} = (0, 4, 0) - (3, 0, 5) = (-3, 4, -5)$

c. $|\overrightarrow{CF}| = \sqrt{9 + 16 + 25} = 5\sqrt{2}$

$$\overrightarrow{OP} = (3, 4, 5)$$

$$|\overrightarrow{OP}| = \sqrt{9 + 16 + 25} = 5\sqrt{2}$$

$$\overrightarrow{CF} \cdot \overrightarrow{OP} = -9 + 16 - 25 = -18$$

$$\begin{aligned}\theta &= \cos^{-1}\left(\frac{-18}{50}\right) \\ &\doteq 111.1^\circ\end{aligned}$$

27.

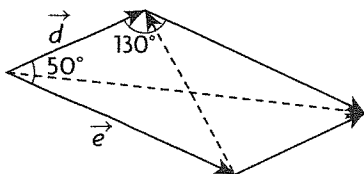

a. Using properties of parallelograms, we know that the other angle is 130° (Angles must add up to 360° , opposite angles are congruent).

Using the cosine law,

$$|\vec{d} + \vec{e}|^2 = 3^2 + 5^2 - 2(3)(5)\cos 130^\circ$$

$$|\vec{d} + \vec{e}| \doteq 7.30$$

b. Using the cosine law,

$$|\vec{d} - \vec{e}|^2 = 3^2 + 5^2 - 2(3)(5)\cos 50^\circ$$

$$|\vec{d} - \vec{e}| \doteq 3.84$$

c. $\vec{e} - \vec{d}$ is the vector in the opposite direction of $\vec{d} - \vec{e}$, but with the same magnitude. So:

$$|\vec{e} - \vec{d}| = |\vec{d} - \vec{e}| \doteq 3.84$$

28. a. Scalar: $\frac{(\vec{i} + \vec{j}) \cdot (\vec{i})}{|\vec{i}|} = 1$

Vector: $1\left(\frac{\vec{i}}{|\vec{i}|}\right) = \vec{i}$

b. Scalar: $\frac{(\vec{i} + \vec{j}) \cdot (\vec{j})}{|\vec{j}|} = 1$

Vector: $1\left(\frac{\vec{j}}{|\vec{j}|}\right) = \vec{j}$

c. Scalar: $\frac{(\vec{i} + \vec{j}) \cdot (\vec{k} + \vec{j})}{|\vec{k} + \vec{j}|} = \frac{1}{\sqrt{2}}$

Vector: $\frac{1}{\sqrt{2}} \cdot \frac{(\vec{k} + \vec{j})}{|\vec{k} + \vec{j}|} = \frac{1}{2}(\vec{k} + \vec{j})$

29. a. If its magnitude is 1, it's a unit vector:

$$|\vec{a}| = \sqrt{\frac{1}{4} + \frac{1}{9} + \frac{1}{36}} \neq 1 \text{ not a unit vector}$$

$$|\vec{b}| = \sqrt{\frac{1}{3} + \frac{1}{3} + \frac{1}{3}} = 1, \text{ unit vector}$$

$$|\vec{c}| = \sqrt{\frac{1}{4} + \frac{1}{2} + \frac{1}{4}} = 1, \text{ unit vector}$$

$$|\vec{d}| = \sqrt{1 + 1 + 1} \neq 1, \text{ not a unit vector}$$

b. \vec{a} is. When dotted with \vec{d} , it equals 0.

30. $25 \cdot \sin(30^\circ) \cdot 0.6 = 7.50 \text{ J}$

31. a. $\vec{a} \cdot \vec{b} = 6 - 5 - 1 = 0$

b. \vec{a} with the x -axis:

$$|\vec{a}| = \sqrt{4 + 25 + 1} = \sqrt{30}$$

$$\cos(\alpha) = \frac{2}{\sqrt{30}}$$

\vec{a} with the y -axis:

$$\cos(\beta) = \frac{5}{\sqrt{30}}$$

\vec{a} with the z -axis:

$$\cos(\gamma) = \frac{-1}{\sqrt{30}}$$

$$|\vec{b}| = \sqrt{9 + 1 + 1} = \sqrt{11}$$

\vec{b} with the x -axis:

$$\cos(\alpha) = \frac{3}{\sqrt{11}}$$

\vec{b} with the y -axis:

$$\cos(\beta) = \frac{-1}{\sqrt{11}}$$

\vec{b} with the z -axis:

$$\cos(\gamma) = \frac{1}{\sqrt{11}}$$

$$\mathbf{c.} \vec{m}_1 \cdot \vec{m}_2 = \frac{6}{\sqrt{330}} - \frac{5}{\sqrt{330}} - \frac{1}{\sqrt{330}} = 0$$

32. Need to show that the magnitudes of the diagonals are equal to show that it is a rectangle.

$$|3\vec{i} + 3\vec{j} + 10\vec{k}| = \sqrt{9 + 9 + 100} = \sqrt{118}$$

$$|-\vec{i} + 9\vec{j} - 6\vec{k}| = \sqrt{1 + 81 + 36} = \sqrt{118}$$

33. a. Direction cosine for x -axis:

$$\cos(30^\circ) = \frac{\sqrt{3}}{2}$$

We know the identity

$$\cos^2 \alpha + \cos^2 \beta + \cos^2 \gamma = 1.$$

Since $\alpha = 30^\circ$, and $\beta = \gamma$, we get

$$2 \cos^2 \beta = 1 - \frac{3}{4}$$

$$\cos \beta = \cos \gamma = \pm \frac{1}{2\sqrt{2}}$$

$$\cos \alpha = \frac{\sqrt{3}}{2}$$

So there are two possibilities, depending upon whether $\beta = \gamma$ is acute or obtuse.

b. If γ is acute, then

$$\cos \gamma = \frac{1}{2\sqrt{2}}$$

$$\gamma \doteq 69.3^\circ$$

If γ is obtuse, then

$$\cos \gamma = \frac{1}{2\sqrt{2}}$$

$$\gamma \doteq 110.7^\circ$$

$$34. \vec{a} \cdot \vec{b} = |\vec{a}||\vec{b}|\cos(\theta) = \frac{1}{2}$$

$$(\vec{a} - 3\vec{b}) \cdot (m\vec{a} + \vec{b}) = 0$$

$$m\vec{a} \cdot \vec{a} + \vec{a} \cdot \vec{b} - 3m\vec{a} \cdot \vec{b} - 3\vec{b} \cdot \vec{b} = 0$$

$$m + \frac{1}{2} - \frac{3}{2}m - \frac{6}{2} = 0$$

$$-\frac{1}{2}m = \frac{5}{2}$$

$$m = -5$$

35.

$$\vec{a} \cdot \vec{b} = 0 - 20 + 12 = -8$$

$$\vec{a} + \vec{b} = (-1, -1, -8)$$

$$|\vec{a} + \vec{b}| = \sqrt{1 + 1 + 64} = \sqrt{66}$$

$$\vec{a} - \vec{b} = (1, 9, -4)$$

$$|\vec{a} - \vec{b}| = \sqrt{1 + 81 + 16} = \sqrt{98}$$

$$\frac{1}{4}|\vec{a} + \vec{b}|^2 - \frac{1}{4}|\vec{a} - \vec{b}|^2 = \frac{66}{4} - \frac{98}{4} = -8$$

$$36. \vec{c} = \vec{b} - \vec{a}$$

$$|\vec{c}|^2 = |\vec{b} - \vec{a}|^2$$

$$= (\vec{b} - \vec{a}) \cdot (\vec{b} - \vec{a})$$

$$= \vec{b} \cdot \vec{b} - \vec{a} \cdot \vec{b} + \vec{a} \cdot \vec{a} - \vec{a} \cdot \vec{b}$$

$$= |\vec{a}|^2 + |\vec{b}|^2 - 2\vec{a} \cdot \vec{b}$$

$$= |\vec{a}|^2 + |\vec{b}|^2 - 2|\vec{a}||\vec{b}|\cos \theta$$

$$37. \vec{AB} = (2, 0, 4)$$

$$|\vec{AB}| = \sqrt{4 + 0 + 16} = 2\sqrt{5}$$

$$\vec{AC} = (1, 0, 2)$$

$$|\vec{AC}| = \sqrt{1 + 0 + 4} = \sqrt{5}$$

$$\vec{BC} = (-1, 0, -2)$$

$$|\vec{BC}| = \sqrt{1 + 0 + 4} = \sqrt{5}$$

$$\cos A = \frac{\vec{AB} \cdot \vec{AC}}{|\vec{AB}||\vec{AC}|}$$

$$= \frac{10}{10}$$

$$= 1$$

But this means that angle $A = 0^\circ$, so that this triangle is degenerate. For completeness, though, notice that $\vec{BC} = -\vec{AC}$ and $\vec{AB} = 2\vec{AC}$. This means that point C sits at the midpoint of the line segment joining A and B . So angle $C = 180^\circ$ and angle $B = 0^\circ$. So

$$\cos B = 1;$$

$$\cos C = -1.$$

The area of triangle ABC is, of course, 0.

Chapter 7 Test, p. 422

1. a. We use the diagram to calculate $\vec{a} \times \vec{b}$, noting $a_1 = -1, a_2 = 1, a_3 = 1$ and $b_1 = 2, b_2 = 1, b_3 = -3$.

$$\vec{a} \quad \vec{b}$$

$$\begin{array}{c} 1 \\ 1 \\ -1 \\ 1 \end{array} \quad \begin{array}{c} 1 \\ -3 \\ 2 \\ 1 \end{array}$$

$$x = 1(-3) - 1(1) = -4$$

$$y = 1(2) - (-1)(-3) = -1$$

$$z = -1(1) - 1(2) = -3$$

$$\text{So, } \vec{a} \times \vec{b} = (-4, -1, -3)$$

b. We use the diagram again:

$$\begin{array}{r} \vec{b} \quad \vec{c} \\ \begin{array}{c} 1 \quad 1 \\ \swarrow \quad \searrow \\ -3 \quad -7 \\ \swarrow \quad \searrow \\ 2 \quad 5 \\ \swarrow \quad \searrow \\ 1 \quad 1 \end{array} \end{array} \quad \begin{array}{l} x = 1(-7) - (-3)(1) = -4 \\ y = -3(5) - (2)(-7) = -1 \\ z = 2(1) - 1(5) = -3 \end{array}$$

So, $\vec{b} \times \vec{c} = (-4, -1, -3)$

c. $\vec{a} \cdot (\vec{b} \times \vec{c}) = (-1, 1, 1) \cdot (-4, -1, -3)$
 $= (-1)(-4) + (1)(-1) + (1)(-3)$
 $= 0$

d. We could use the diagram method again, or, we note that for any vectors \vec{x}, \vec{y} , $\vec{x} \times \vec{y} = -(\vec{y} \times \vec{x})$, so letting $\vec{y} = \vec{x}$, we have $\vec{x} \times \vec{x} = 0$ from the last equation. Since $\vec{a} \times \vec{b} = \vec{b} \times \vec{c}$ from the first two parts of the problem, $(\vec{a} \times \vec{b}) \times (\vec{b} \times \vec{c}) = 0$.

2. a. To find the scalar and vector projections of \vec{a} on \vec{b} , we need to calculate $\vec{a} \cdot \vec{b}$ and $|\vec{b}| = \sqrt{\vec{b} \cdot \vec{b}}$

$$\begin{aligned} \vec{a} \cdot \vec{b} &= (1, -1, 1) \cdot (2, -1, -2) \\ &= (1)(2) + (-1)(-1) + (1)(-2) \\ &= 1 \\ |\vec{b}| &= \sqrt{2^2 + (-1)^2 + (-2)^2} \\ &= 3 \end{aligned}$$

So, $|\vec{b}| = 3$

The scalar projection of \vec{a} on \vec{b} is $\frac{\vec{a} \cdot \vec{b}}{|\vec{b}|} = \frac{1}{3}$, and

the vector projection of \vec{a} on \vec{b} is

$$\left(\frac{\vec{a} \cdot \vec{b}}{|\vec{b}|^2}\right)\vec{b} = \frac{1}{9}(2, -1, -2).$$

b. We find the direction cosines for \vec{b} :

$$\begin{aligned} \cos(\alpha) &= \frac{b_1}{|\vec{b}|} = \frac{2}{3} \\ \alpha &\doteq 48.2^\circ. \end{aligned}$$

$$\begin{aligned} \cos(\beta) &= \frac{b_2}{|\vec{b}|} = \frac{-1}{3} \\ \beta &\doteq 109.5^\circ. \end{aligned}$$

$$\begin{aligned} \cos(\gamma) &= \frac{b_3}{|\vec{b}|} = \frac{-2}{3} \\ \gamma &\doteq 131.8^\circ. \end{aligned}$$

c. The area of the parallelogram is the magnitude of the cross product.

$$\begin{array}{r} \vec{a} \quad \vec{b} \\ \begin{array}{c} -1 \quad -1 \\ \swarrow \quad \searrow \\ 1 \quad -2 \\ \swarrow \quad \searrow \\ 1 \quad 2 \\ \swarrow \quad \searrow \\ -1 \quad -1 \end{array} \end{array} \quad \begin{array}{l} x = (-1)(-2) - 1(-1) = 3 \\ y = 1(2) - (1)(-2) = 4 \\ z = (1)(-1) - (-1)(2) = 1 \end{array}$$

So, $\vec{a} \times \vec{b} = (3, 4, 1)$ and thus,

$$\begin{aligned} |\vec{a} \times \vec{b}| &= \sqrt{3^2 + 4^2 + 1^2} \\ &= \sqrt{26} \end{aligned}$$

So the area of the parallelogram formed by \vec{a} and \vec{b} is $\sqrt{26}$ or 5.10 square units.

3. We first draw a diagram documenting the situation:

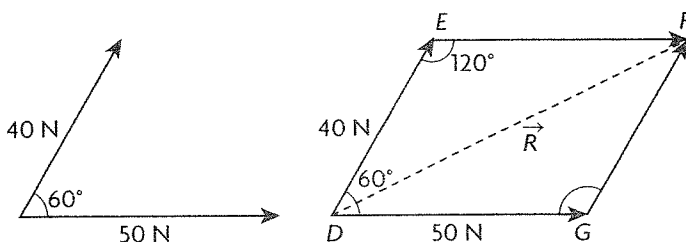

In triangle DEF , we use the cosine law:

$$\begin{aligned} |\vec{R}| &= \sqrt{40^2 + 50^2 - 2(40)(50)\cos(120^\circ)} \\ |\vec{R}| &\doteq 78.10 \end{aligned}$$

We now use the sine law to find $\angle EDF$:

$$\begin{aligned} \frac{\sin \angle EDF}{|\vec{EF}|} &= \frac{\sin \angle DEF}{|\vec{R}|} \\ \frac{\sin \angle EDF}{50} &= \frac{\sin 120^\circ}{78.10} \end{aligned}$$

$$\begin{aligned} \sin \angle EDF &\doteq 0.5544 \\ \angle EDF &\doteq 33.7^\circ \end{aligned}$$

The equilibrant force is equal in magnitude and opposite in direction to the resultant force, so both forces have a magnitude of 78.10 N. The resultant makes an angle 33.7° to the 40 N force and 26.3° to the 50 N force. The equilibrant makes an angle 146.3° to the 40 N force and 153.7° to the 50 N force.

4. We find the resultant velocity of the airplane.

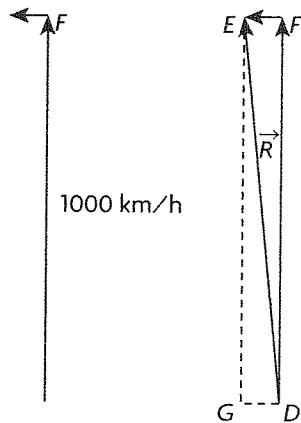

Position diagram Vector diagram

Since the airplane's velocity is perpendicular to the wind, the resultant's magnitude is given by the Pythagorean theorem:

$$|\vec{R}| = \sqrt{1000^2 + 100^2}$$

$$|\vec{R}| \doteq 1004.99$$

The angle is determined using the tangent ratio:

$$\tan \angle EDF = \frac{100}{1000}$$

$$\angle EDF \doteq 5.7^\circ$$

Thus, the resultant velocity is 1004.99 km/h, N 5.7° W (or W 84.3° N).

5. a. The canoeist will travel 200 m across the stream, so the total time he will paddle is:

$$t = \frac{d}{r_{\text{canoeist}}}$$

$$t = \frac{200 \text{ m}}{2.5 \text{ m/s}}$$

$$t = 80 \text{ s}$$

The current is flowing 1.2 m/s downstream, so the distance that the canoeist travels downstream is:

$$d = r_{\text{current}} \times t$$

$$d = (1.2 \text{ m/s})(80 \text{ s})$$

$$d = 96 \text{ m}$$

So, the canoeist will drift 96 m south.

b. In order to arrive directly across stream, the canoeist must take into account the change in his velocity caused by the current. That is, he must initially paddle upstream in a direction such that the resultant velocity is directed straight across the stream. The resultant velocity:

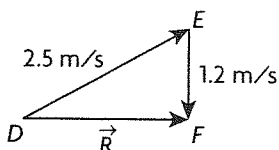

Since the resultant velocity is perpendicular to the current, the direction in which the canoeist should head is determined by the sine ratio.

$$\sin \angle EDF = \frac{1.2}{2.5}$$

$$\angle EDF \doteq 28.7^\circ$$

The canoeist should head 28.7° upstream.

6. The area of the triangle is exactly:

$$A_{\Delta ABC} = \frac{1}{2} |\vec{AB} \times \vec{BC}|$$

$$\vec{AB} = (2, 1, 3) - (-1, 3, 5)$$

$$= (3, -2, -2)$$

$$\vec{BC} = (-1, 1, 4) - (2, 1, 3)$$

$$= (-3, 0, 1)$$

$$\vec{AB} \quad \vec{BC}$$

$$\begin{array}{r} -2 \\ -2 \\ 3 \\ -2 \end{array} \begin{array}{r} x \\ y \\ z \\ 0 \end{array} \begin{array}{r} 0 \\ 1 \\ 3 \\ 0 \end{array}$$

$$x = (-2)(1) - (-2)(0) = -2$$

$$y = (-2)(-3) - (3)(1) = 3$$

$$z = (3)(0) - (-2)(-3) = -6$$

$$\text{So, } \vec{AB} \times \vec{BC} = (-2, 3, -6) \text{ and}$$

$$|\vec{AB} \times \vec{BC}| = \sqrt{(-2)^2 + 3^2 + (-6)^2}$$

$$= \sqrt{49}$$

$$= 7$$

$$\text{So, } A_{\Delta ABC} = \frac{1}{2} |\vec{AB} \times \vec{BC}| = \frac{7}{2}$$

The area of the triangle is 3.50 square units.

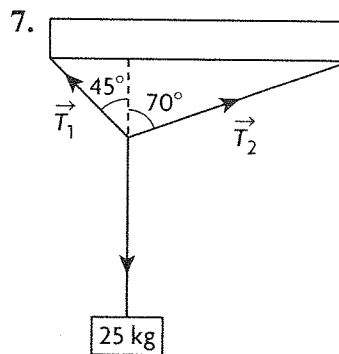

The system is in equilibrium (i.e. it is not moving), so we know that the horizontal components of \vec{T}_1 and \vec{T}_2 are equal:

$$|\vec{T}_1| \sin(45^\circ) = |\vec{T}_2| \sin(70^\circ)$$

$$|\vec{T}_2| = \frac{\sin(45^\circ)}{\sin(70^\circ)} |\vec{T}_1|$$

Also, the vertical component of $\vec{T}_1 + \vec{T}_2$ must equal the gravitational force on the block:

$$|\vec{T}_1|\cos 45^\circ + |\vec{T}_2|\cos 70^\circ = (25 \text{ kg})(9.8 \text{ m/s}^2)$$

Substituting in for \vec{T}_2 , we find that:

$$|\vec{T}_1|\cos 45^\circ + |\vec{T}_1|\frac{\sin 45^\circ}{\sin 70^\circ}\cos 70^\circ = (25 \text{ kg})(9.8 \text{ m/s}^2)$$

$$|\vec{T}_1|\left(\cos 45^\circ + \frac{\sin 45^\circ}{\sin 70^\circ}\cos 70^\circ\right) = 245 \text{ N}$$

$$|\vec{T}_1|(0.9645) \doteq 245 \text{ N}$$

$$|\vec{T}_1| \doteq 254.0 \text{ N}$$

So, we can now find

$$|\vec{T}_2| = \frac{\sin(45^\circ)}{\sin(70^\circ)}|\vec{T}_1|$$

$$|\vec{T}_2| \doteq \frac{\sin(45^\circ)}{\sin(70^\circ)}(254.0 \text{ N})$$

$$|\vec{T}_2| \doteq 191.1 \text{ N}$$

The direction of the tensions are indicated in the diagram.

8. a. We explicitly calculate both sides of the equation. The left side is:

$$\begin{aligned}\vec{x} \cdot \vec{y} &= (3, 3, 1) \cdot (-1, 2, -3) \\ &= (3)(-1) + (3)(2) + (1)(-3) \\ &= 0\end{aligned}$$

We perform a few computations before computing the right side:

$$\begin{aligned}\vec{x} + \vec{y} &= (3, 3, 1) + (-1, 2, -3) \\ &= (2, 5, -2)\end{aligned}$$

$$\begin{aligned}|\vec{x} + \vec{y}|^2 &= (\vec{x} + \vec{y}) \cdot (\vec{x} + \vec{y}) \\ &= 2^2 + 5^2 + (-2)^2 \\ &= 33\end{aligned}$$

$$\begin{aligned}\vec{x} - \vec{y} &= (3, 3, 1) - (-1, 2, -3) \\ &= (4, 1, 4)\end{aligned}$$

$$\begin{aligned}|\vec{x} - \vec{y}|^2 &= (\vec{x} - \vec{y}) \cdot (\vec{x} - \vec{y}) \\ &= 4^2 + 1^2 + 4^2 \\ &= 33\end{aligned}$$

Thus, the right side is

$$\begin{aligned}\frac{1}{4}|\vec{x} + \vec{y}|^2 - \frac{1}{4}|\vec{x} - \vec{y}|^2 &= \frac{1}{4}(33) - \frac{1}{4}(33) \\ &= 0\end{aligned}$$

So, the equation holds for these vectors.

b. We now verify that the formula holds in general. We will compute the right side of the equation, but we first perform some intermediary computations:

$$\begin{aligned}|\vec{x} + \vec{y}|^2 &= (\vec{x} + \vec{y}) \cdot (\vec{x} + \vec{y}) \\ &= (\vec{x} \cdot \vec{x}) + (\vec{x} \cdot \vec{y}) + (\vec{y} \cdot \vec{x}) + (\vec{y} \cdot \vec{y}) \\ &= (\vec{x} \cdot \vec{x}) + 2(\vec{x} \cdot \vec{y}) + (\vec{y} \cdot \vec{y})\end{aligned}$$

$$\begin{aligned}|\vec{x} - \vec{y}|^2 &= (\vec{x} - \vec{y}) \cdot (\vec{x} - \vec{y}) \\ &= (\vec{x} \cdot \vec{x}) + (\vec{x} \cdot -\vec{y}) + (-\vec{y} \cdot \vec{x}) \\ &\quad + (-\vec{y} \cdot -\vec{y}) \\ &= (\vec{x} \cdot \vec{x}) - 2(\vec{x} \cdot \vec{y}) + (\vec{y} \cdot \vec{y})\end{aligned}$$

So, the right side of the equation is:

$$\begin{aligned}\frac{1}{4}|\vec{x} + \vec{y}|^2 - \frac{1}{4}|\vec{x} - \vec{y}|^2 &= \frac{1}{4}(4(\vec{x} \cdot \vec{y})) \\ &= \vec{x} \cdot \vec{y}\end{aligned}$$

Thus, the equation holds for arbitrary vectors.