

## **PASS MOCK EXAM – FOR PRACTICE ONLY**

Dates and locations of mock exam take-up:

1. Tuesday October 16 2012, 6:00-7:30 in RB 1201
2. Thursday October 18 2012, 6:00-7:30 in TB 204

### **IMPORTANT:**

It is most beneficial to you to write this mock midterm UNDER EXAM CONDITIONS. This means:

- Complete the midterm in 2.5 hour(s).
- Work on your own.
- Keep your notes and textbook closed.
- Attempt every question.

The purpose of this mock exam is to give you practice answering questions in a timed setting and to help you to gauge which aspects of the course content you know well and which are in need of further development and review. Use this mock exam as a learning tool in preparing for the actual exam.

Please note:

- Come to the PASS session with your mock exam complete. There, you can work with other students to review your work.
- Often, there is not enough time to review the entire exam in the PASS session. Decide which questions you most want to review – the facilitator may ask students to vote on which questions they want to discuss.
- Facilitators do not bring copies of the mock exam to the session. Please print out and complete the exam before you attend.
- Facilitators do not produce or distribute an answer key for mock exams. Facilitators help students to work together to compare and assess the answers they have. If you are not able to attend the PASS session, you can work alone or with others in the class.

2.5 hour exam. Closed book.

### Problem 1

Determine the magnitude of  $\mathbf{P}$  and coordinate direction angles of  $\mathbf{F}_3$  required for equilibrium of the particle. Note that  $\mathbf{F}_3$  acts in the octant shown.

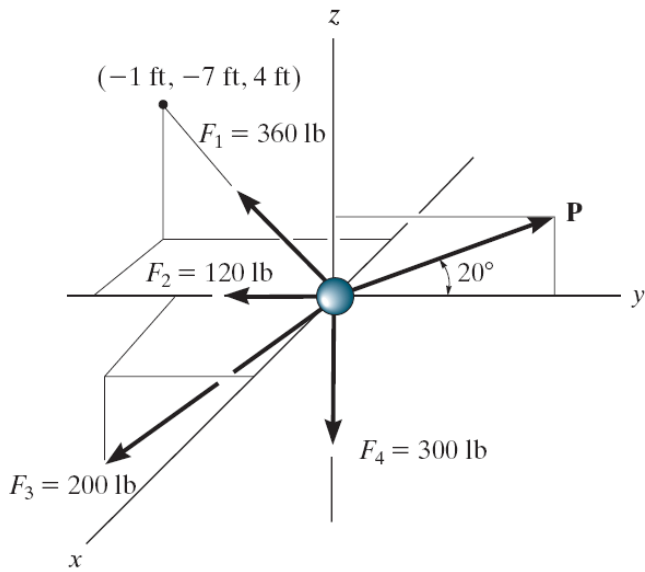

## Problem 2

Determine the magnitude of the projected component of the 100-lb force acting along and perpendicular to the axis BC of the pipe.

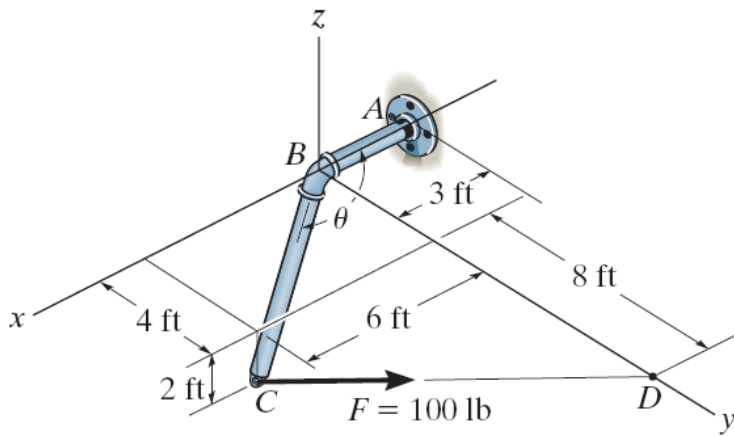

### Problem 3

If the tension in the cable is  $F = 140$  lb, determine the magnitude of the moment produced by this force about the hinged axis,  $CD$ , of the panel.

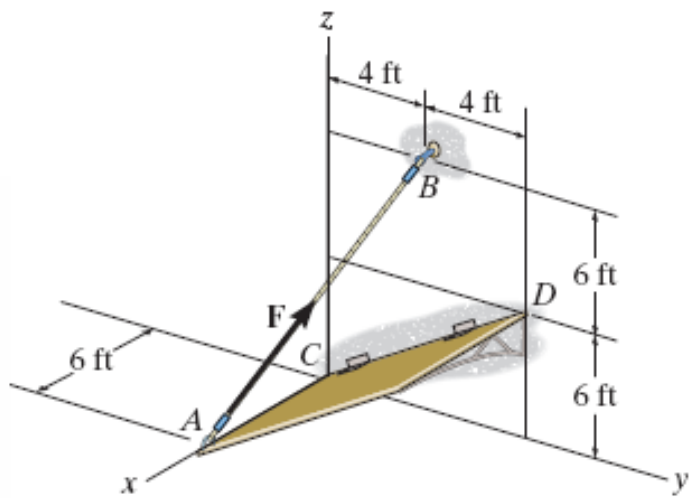

**Problem 4**

Determine the force  $P$  required to pull the 50-kg roller over the smooth step. Take  $\theta=60^\circ$ .

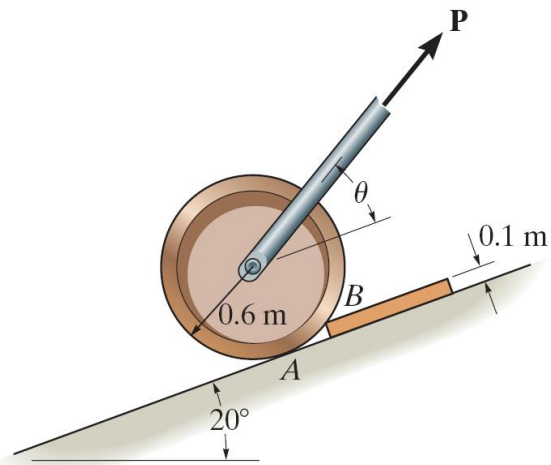

### Problem 5

Replace the force and couple moment system acting on the overhang beam by a resultant force, and specify its location along AB measured from point A.

