



# Université d'Ottawa • University of Ottawa

Faculté des sciences  
Physique

Faculty of Science  
Physics

PHY1122, PHY1102

April 18, 2007

Final open-book examination: 3 hours

Dr. Z.M. Stadnik

Page 1 of 11 pages

The answers should be entered carefully on a computer readable sheet using an HP pencil. At the end of the examination, only the computer sheet should be handed over to a proctor. The student can keep this questionnaire.

1. Water emerges from a faucet of diameter 3.0 cm in steady, near vertical flow with speed 2.0 m/s. At the distance 10 cm below the faucet, the diameter of the falling water column is

- 3.0 cm.  
→  B) 2.7 cm.  
C) 2.5 cm.  
D) 2.1 cm.  
E) None of the above.

- ✓ 2. If the plate separation of an isolated charged parallel-plate capacitor is doubled,

- A) the electric field is doubled.  
 B) the potential difference is halved.  
C) the charge on each plate is halved.  
D) the area charge density on each plate is doubled.  
 E) None of the above.

3.

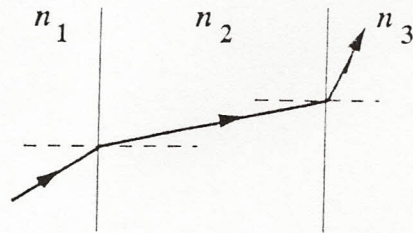

The figure shows the path of a portion of a ray of light as it passes through three different materials. *The figure is drawn to scale.* What can be concluded concerning the refractive indices of these three materials?

- A)  $n_3 < n_1 < n_2$   
 B)  $n_1 < n_2 < n_3$   
 C)  $n_1 > n_2 > n_3$   
 D)  $n_2 < n_1 < n_3$   
 E)  $n_1 < n_3 < n_2$

✓ 4.

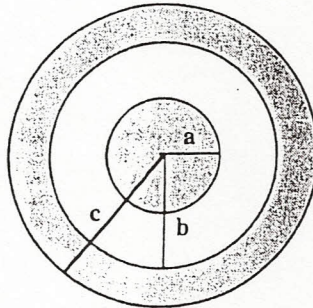

A solid conducting sphere of radius  $a$  carries an excess charge of  $+6 \mu\text{C}$ . This sphere is located at the center of a hollow conducting sphere with an inner radius of  $b$  and an outer radius of  $c$ , as shown in the figure above. The hollow sphere also carries a total excess charge of  $+6 \mu\text{C}$ . The excess charge on the *inner surface* of the outer sphere (a distance  $b$  from the center of the system) is

- A)  $+12 \mu\text{C}$ .  
 B)  $-12 \mu\text{C}$ .  
 C)  $+6 \mu\text{C}$ .  
 D)  $-6 \mu\text{C}$ .  
 E) zero.

31. An 11 mm wide diffraction grating has rulings of 550 lines per mm. Light is incident normally on the grating. The longest wavelength that forms an intensity maximum in the fifth order is closest to

- A) 488 nm.
- B) 463 nm.
- C) 513 nm.
- D) 538 nm.
- E) 563 nm.

5. An empty capacitor of capacitance  $C$  is connected to a 6-V battery. When a dielectric material (dielectric constant = 4) is inserted between the plates of this capacitor, it is observed that the magnitude of the surface charge on the dielectric adjacent to either plate of the capacitor is  $60 \mu\text{C}$ . The value of  $C$  is

- A)  $2.7 \mu\text{F}$ .  
 B)  $3.0 \mu\text{F}$ .  
 C)  $3.3 \mu\text{F}$ .  
 D)  $5.2 \mu\text{F}$ .  
 E) None of the above.

✓ 6.

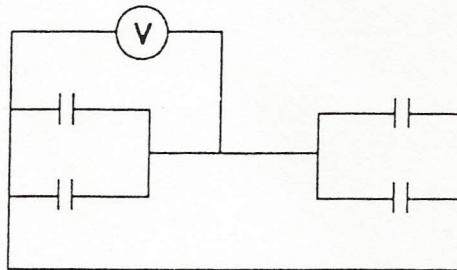

Each of the four capacitors shown is  $500 \mu\text{F}$ . The voltmeter reads 500 V. The magnitude of the charge on each capacitor plate is

- A) 2.0 C.  
 B) 1.0 C.  
 C) 0.5 C.  
 D) 0.25 C.  
 E) None of the above.

- ✓ 7. How long will it take a charged  $80\text{-}\mu\text{F}$  capacitor to lose 40% of its initial energy if it is allowed to discharge through a  $45\text{-}\Omega$  resistor?

- A) 0.52 ms  
 B) 2.0 ms  
 C) 1.1 ms  
 D) 0.92 ms  
 E) None of the above.

8. A 100-kΩ resistor and a 200-kΩ resistor are in series, with a 300-V potential difference across the combination. A digital meter with a 3-significant-digit display and 2.0-MΩ resistance is used to measure the voltage across the 200-kΩ resistor. What does it read?

- A) 200 V
- B) 194 V
- C) 124 V
- D) 110 V
- E) None of the above.

$R_1 = 100$      $R_2 = 200 \times 10^3$      $V_2 = \pm R_2$   
 $R_m = 2 \text{ M}\Omega = 2 \times 10^6$      $= \frac{R_2}{R_1 + R_2} V_{ab}$   
 $\frac{1}{R_{11}} = \frac{1}{R_1} + \frac{1}{R_2} = 9.5233 \times 10^{-6}$      $= \frac{95238}{300}$   
 $R_{11} = 10510$

9. A diver shines an underwater searchlight at the surface of a pond. Below what angle *relative to the surface* will the light be totally reflected? The index of refraction for water is 1.33.

- A) 27°
- B) 37°
- C) 41°
- D) 49°
- E) 56°

10. A beaker has a height of 40.0 cm. The lower half of the beaker is filled with water ( $n = 1.33$ ) and the upper part is filled with oil ( $n = 1.48$ ). To a person looking down into the beaker from above, the apparent depth of the bottom is

- A) 21.4 cm.
- B) 28.6 cm.
- C) 32.4 cm.
- D) 40.0 cm.
- E) None of the above.

$n_w = 1.33$   
 $n_o = 1.48$   
 $n_a = 1.0$   
 $d' = \frac{n_2}{n_1} d$   
 $d'' = \frac{n_o}{n_w} \left( \frac{d}{2} \right) = \frac{1.48}{1.33} \left( \frac{40}{2} \right) = 22.3$

$d'' = \frac{n_a}{n_o} d'' =$

11.

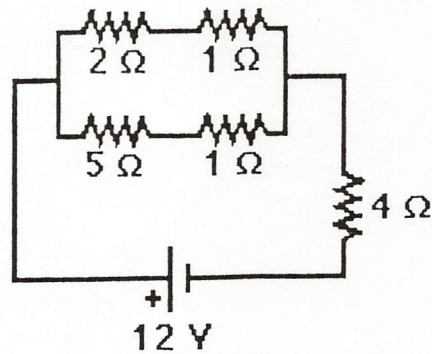

What is the power dissipated in the 2- $\Omega$  resistance in the circuit shown here?

- A) 5.33 W  
 B) 8.0 W  
 C) 6.67 W  
 D) 2.67 W  
 E) 3.56 W
12. For an ideal gas the internal energy  $U$  depends only on
- A) volume.  
 B) entropy.  
 C) the amount of heat added to it.  
 D) temperature.  
 E) pressure.
13. In a stack of three polarizing sheets, the first and third are crossed while the middle one has its axis at  $45^\circ$  to the axes of the other two. The fraction of the intensity of an incident unpolarized beam of light that is transmitted by the stack is
- A)  $1/2$ .  
 B)  $1/3$ .  
 C)  $1/4$ .  
 D)  $1/8$ .  
 E) zero.

14.

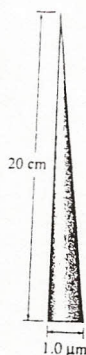

A rectangular wire loop 20 cm high is dipped into a soap solution and then held vertically, producing a soap film whose thickness varies linearly from essentially zero at the top to  $1.0 \mu\text{m}$  at the bottom. At what distance from the top of the film will the first bright band appear if the film is illuminated with 550-nm light? The refractive index of the film is 1.33.

- A) 2.07 cm
- B) 6.20 cm
- C) 1.69 cm
- D) 5.08 cm
- E) None of the above.

15. A student is floating in a boat in a swimming pool. There are some large stones, with a density of  $2.5 \text{ g/cm}^3$ , in the boat. The student throws the stones out of the boat such that they sink to the bottom of the pool. The water level  $h$ , measured vertically at the end of the pool, \_\_\_\_\_ as the stones are thrown out.

- A) stays the same.
- B) decreases.
- C) increases.
- D) There is not enough information to solve the problem.

16. A horizontal pipe narrows from a diameter of 10 cm to 5 cm. For a fluid flowing from the larger diameter to the smaller,

- A) the velocity and pressure both increase.
- B) the velocity increases and the pressure decreases.
- C) the velocity decreases and the pressure increases.
- D) the velocity and pressure both decrease.
- E) either the velocity or the pressure changes but not both.

L  
P  
V  
T  
||

17. If both the temperature and the volume of an ideal gas are doubled, the pressure will be
- A) increased by a factor of 4.
  - B) doubled also.
  - C) unchanged.
  - D) diminished by a factor of 4.
  - E) None of the above.
18. If the absolute temperature of a gas is doubled, what is the change in the average kinetic energy of its molecules?
- A) There is no change.
  - B) It increases by a factor of 2.
  - C) It decreases by a factor of 2.
  - D) It increases by a factor of  $\sqrt{2}$ .
  - E) It decreases by a factor of  $\sqrt{2}$ .
19. Aluminum has a specific heat more than twice that of copper. Identical masses of aluminum and copper, both at  $0^{\circ}\text{C}$ , are dropped together into a can of hot water. When the system has come to equilibrium,
- A) the aluminum is at a higher temperature than the copper.
  - B) the copper is at a higher temperature than the aluminum.
  - C) the aluminum and copper are at the same temperature.
  - D) the difference in temperature between the aluminum and the copper depends on the amount of water in the can.
  - E) the difference in temperature between the aluminum and the copper depends on the initial temperature of water in the can.
20. A 6.0-g lead bullet traveling at 300 m/s penetrates a wooden block and stops. If 50% of the initial kinetic energy of the bullet is converted into thermal energy in the bullet, by how much does the bullet's temperature increase? The specific heat of lead is  $128 \text{ J/kg}\cdot\text{K}$ .
- A)  $0.17 \text{ C}^{\circ}$
  - B)  $180 \text{ C}^{\circ}$
  - C)  $17 \text{ C}^{\circ}$
  - D)  $350 \text{ C}^{\circ}$
  - E)  $35 \text{ C}^{\circ}$

21. A balloon contains a gas at a pressure 1.2 atm and has a volume of  $0.10 \text{ m}^3$ . More gas is pumped into the balloon at constant pressure until the volume is doubled. How much work is done by the pump?
- A) 12 J
  - B)  $2.4 \times 10^4 \text{ J}$
  - C) 24 J
  - D)  $1.2 \times 10^4 \text{ J}$
  - E)  $6.1 \times 10^3 \text{ J}$
22. The amount of linear expansion of a long rod does NOT depend on
- A) the original length of the rod.
  - B) the specific heat of the rod.
  - C) the change in the absolute temperature of the rod.
  - D) the coefficient of linear expansion.
  - E) the material out of which the rod is made.
23. Astronauts pressurize an evacuated space station by discharging 770 mol of air from a 400-L cylinder into the station's  $15\text{-m}^3$  volume. The gas temperature remains at 290 K. How much work becomes unavailable as a result of this process?
- A)  $7.6 \times 10^6 \text{ J}$
  - B)  $7.0 \times 10^6 \text{ J}$
  - C)  $6.7 \times 10^6 \text{ J}$
  - D)  $5.6 \times 10^6 \text{ J}$
  - E) None of the above.
24. A refrigerator extracts heat  $Q$  from a cold reservoir. The heat exhausted to the hot reservoir
- A) is  $Q$ .
  - B) must be greater than  $Q$ .
  - C) must be less than  $Q$ .
  - D) is zero.

25. Two 1-kg point masses with equal charges  $Q$  are suspended by light strings of length 1 m from a point. The strings hang at  $30^\circ$  to the vertical. The value of  $Q$  is

- (A)  $2.5 \times 10^{-5}$  C.  
 B)  $3.7 \times 10^{-5}$  C.  
 C)  $7.4 \times 10^{-5}$  C.  
 D)  $8.4 \times 10^{-5}$  C.  
 E) None of the above.

26.

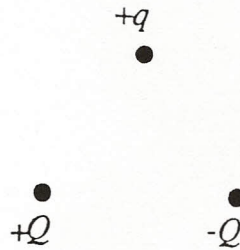

Three charges,  $+q$ ,  $+Q$ , and  $-Q$ , are placed at the corners of an equilateral triangle, as shown. The net force on charge  $+q$  due to the other two charges is

- A) vertically up.  
 B) vertically down.  
 C) zero.  
 D) horizontal to the left.  
 (E) horizontal to the right
27. A solid spherical conductor has a radius of 15 cm. The electric field 30 cm from the center of this sphere has a magnitude of 800 N/C. The surface charge density on the sphere is

- A)  $7.1 \times 10^{-9}$  C/m<sup>2</sup>.  
 B)  $1.0 \times 10^{-8}$  C/m<sup>2</sup>.  
 C)  $1.4 \times 10^{-8}$  C/m<sup>2</sup>.  
 (D)  $2.8 \times 10^{-8}$  C/m<sup>2</sup>.  
 E)  $1.1 \times 10^{-7}$  C/m<sup>2</sup>.

28.



Two charged metal spheres are connected by a wire. Sphere A is larger than sphere B, as shown. The magnitude of the electric potential of sphere A

- A) is greater than that at the surface of sphere B.
- B) is less than that at the surface of sphere B.
- C) is the same as that at the surface of sphere B.
- D) could be greater than or less than that at the surface of sphere B, depending on the radii of the spheres.
- E) could be greater than or less than that at the surface of sphere B, depending on the charge on the spheres.

29.

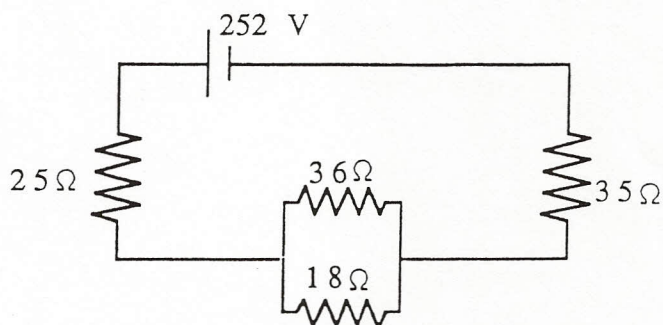

In the circuit shown, the power dissipated in the 18-Ω resistor is

- A) 150 W. ?
- B) 98 W. ?
- C) 33 W. ?
- D) 160 W.
- No. E) None of the above.

30. Battery A has a relatively high internal resistance, whereas battery B has a low internal resistance. If both batteries provide the same current to some external circuitry, which of the following statements is likely to be true?

- A) Both batteries are equally warm to the touch.
- B) Battery A is warmer to the touch than battery B.
- C) Battery B is warmer to the touch than battery A.
- D) Battery A is cooler to the touch than battery B.
- E) The emf of each battery must be known in order to contrast the batteries' warmth to touch.